

PAPER • OPEN ACCESS

## Requirements for the machine providing the formation of irrigation foundations

To cite this article: A U Atajanov *et al* 2022 *IOP Conf. Ser.: Earth Environ. Sci.* **1076** 012034

View the [article online](#) for updates and enhancements.

### You may also like

- [Nanomaterials science](#)  
Heinrich Rohrer
- [The effect of duration of giving Cinnamononi Extract as a growth promoter feed additive and antimicrobial to broiler's performance on organic breeding](#)  
Ahadiyah Yuniza, Yose Rizal and Afriani Sandra
- [New Understanding Physics for Advanced Level](#)  
Jim Breithaupt



**ECS** The Electrochemical Society  
Advancing solid state & electrochemical science & technology

### 242nd ECS Meeting

Oct 9 – 13, 2022 • Atlanta, GA, US

Early hotel & registration pricing ends September 12

Presenting more than 2,400 technical abstracts in 50 symposia

The meeting for industry & researchers in

**BATTERIES**  
**ENERGY TECHNOLOGY**  
**SENSORS AND MORE!**

 Register now!

 **ECS Plenary Lecture featuring M. Stanley Whittingham,**  
Binghamton University  
Nobel Laureate –  
2019 Nobel Prize in Chemistry



# Requirements for the machine providing the formation of irrigation foundations

A U Atajanov, I J Hudaev, F A Bekchanov and L K Babajanov

“Tashkent Institute of Irrigation and Agricultural Mechanization Engineers” National Research University, Kory Niyoziy str., 39, 100000, Tashkent, Uzbekistan

E-mail: adiljanatajanov@mail.ru

**Abstract.** Rational use of water resources, improvement and development of new technology and technical means for its implementation, ensuring the economy of irrigation water is one of the most important issues of today. This article is devoted to the issues of technology for improving the method of irrigation along furrows and creating a technical means, running in and testing directly on experimental fields, selected in each region of the proposed technology and the created technical means, technical requirements for a machine for cutting furrows with a given slope and profile, as well as analysis the results obtained. A database has been created for the mechanization of existing technologies and technical means of cutting furrows along a given slope and compaction of soil in their beds with the formation of a design section and a longitudinal profile of a furrow on the lands of farms in arid zones. A project of technological maps for the production of cutting grooves with a given slope and with a variable density of their bed, taking into account the granulometric and volumetric composition of the lumps, has been drawn up.

## 1. Introduction

One of the most important issues in the world is to improve the reclamation state of irrigated lands. The main goal of the intensification of irrigated agriculture is to increase the effective soil fertility. Under irrigation conditions, the level of soil fertility is largely determined by the relief, the state of the surface of the sown area [1]. Long-term studies of world scientists give full reason to believe that the state of the surface of irrigated lands does not yet meet the requirements of intensification and mechanization of agricultural production, the unevenness of the relief does not allow full use of the potential fertility of the land. In these hidden great reserves of increasing the yield of irrigated crops.

The weakening of the attention of farmers to the nature of the relief of irrigated plots is explained by the underestimation of the relationship between the state of the relief and crop yields [2]. In conditions of an acute water shortage, it is urgent in the arid zone to increase the efficiency of the irrigated field. The main link in the irrigation system that creates the potential for fertility is the irrigated area. The effectiveness of reclamation and agro technical impacts depends on the parameters and state of the irrigated area.

## 2. Materials and methods

The technical requirements for the machine have been developed to ensure a stable profile of the cross-section of the furrow and its design slope. The research was carried out on the basis of the methodology adopted at the National Research University "TIIAME", NIIVP and JSC "GSKB-AGROMASH".



Laboratory, experimental and production testing of the machine was carried out to ensure a stable cross-sectional profile and design slope of the furrow [3].

Appointments of the machine is as follows.

1. The furrow cutter is intended for cutting furrows with a given slope of their bottom for any agricultural crops from irrigated along the furrows.

2. The furrow cutter should automatically maintain the longitudinal profile of the furrow when traveling in roughly graded fields.

3. The work of the furrow cutter must be ensured in stable dense soils up to category IV.

4. The furrow cutter should replace similar machines used for furrowing in irrigated areas.

Place in the machine system: The furrow cutter must be part of the “machine system for the comprehensive mechanization of agricultural production”.

Areas of application: The use of the furrow cutter is expected in the republics of Central Asia, where furrow irrigation is carried out.

Working conditions:

1. Soils are mainly loess-like loams and sandy loam of I ... III categories and cemented with gypsum of IV category with stony inclusions no more than 150 mm in diameter.

2. The work of the furrow cutter is provided when driving on roughly planned fields with a transverse slope within the limits of the allowable for stable operation of this kind of machines - 0.01 g in any direction from the horizontal surface.

3. Maintaining the longitudinal profile of the furrow (bottom) with a given slope should be ensured with automatic control, and in the horizontal plane by manually adjusting the direction of movement during operation.

4. The work of the furrow cutter can start from both open temporary sprinklers and closed sprinklers [4,5].

Qualitative indicators of the technological process:

1. Cutting a furrow with a given slope of their bottom is carried out in one pass of the furrow cutter, in which all basic operations are combined;

- digging (cutting) furrows with a width of 300 mm to 500 mm and a depth of 0.1 m to 0.5 m.

2. The design longitudinal profile of the furrow with a given slope of their bottom is obtained by automatic control when the furrow cutter moves along roughly planned fields in accordance with the resolution of the automatic control system.

Technical and operational requirements and indicators regulating reliability:

1. The method of mounting the furrow cutter is not regulated, that is, it can be mounted, semi-mounted or trailed.

2. The average specific pressure on the ground in the working position should not exceed 0.02 MPa, and the maximum - 0.06 MPa. In the transport position, the maximum specific pressure on the ground should not exceed 0.1 MPa [6].

The use of industrial designs of machines for cutting furrows in a new way:

1. Studies of the actual profile of the surface of the irrigated field and the longitudinal profile of irrigation furrows led to the development of a new method for cutting furrows and a device for implementing this method. Based on the results of the analysis of a new method of cutting furrows, we identified the technical feasibility of using a furrow cutter for cutting irrigation furrows in a new way.

2. Today in agriculture for agricultural crops irrigated along the furrows are used agricultural machines with mounted furrow cutting working bodies. In particular, when growing cotton, which is the main agricultural crop in the Republic, a mounted cultivator of the KRH-4 or KHU-4A brand is used for cutting furrows.

3. Below is the classification of linkage mechanisms with a tractor, theoretical studies of the kinematics of industrial furrow cutters used at present [7].

### 3. Results and discussion

Methods for connecting to a tractor. According to the method of connection with tractors or self-propelled chassis, furrow-cutting machines and tools are divided into trailed, mounted and semi-mounted.

Trailed machines are connected to the tractor at one point, and mounted and semi-mounted at three, two or one. The mounted machine is lifted with the ABCDEKD<sup>1</sup> mechanism (Fig. 1).

In the working position, it is connected to the tractor by the F<sup>1</sup> G<sup>1</sup> M<sup>1</sup> D<sup>1</sup> mechanism (Fig. 1, a). The deepening of the working bodies is limited by the support wheel. If the lower link joints D<sup>1</sup> is disengaged, the machine is connected to the tractor at three points: the two joints D<sup>1</sup> and the joint F<sup>1</sup>.

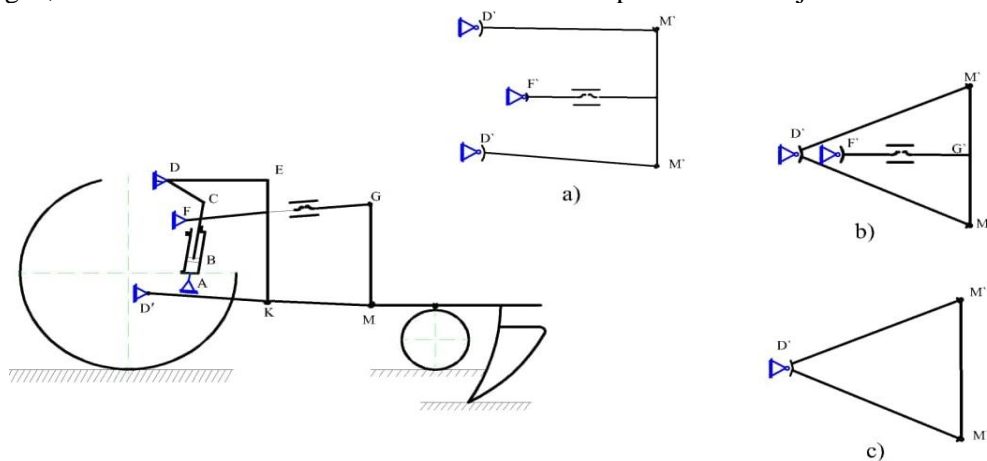

**Figure 1.** Hitch mechanism schemes: a - three-point; b - two-point; c - single point.

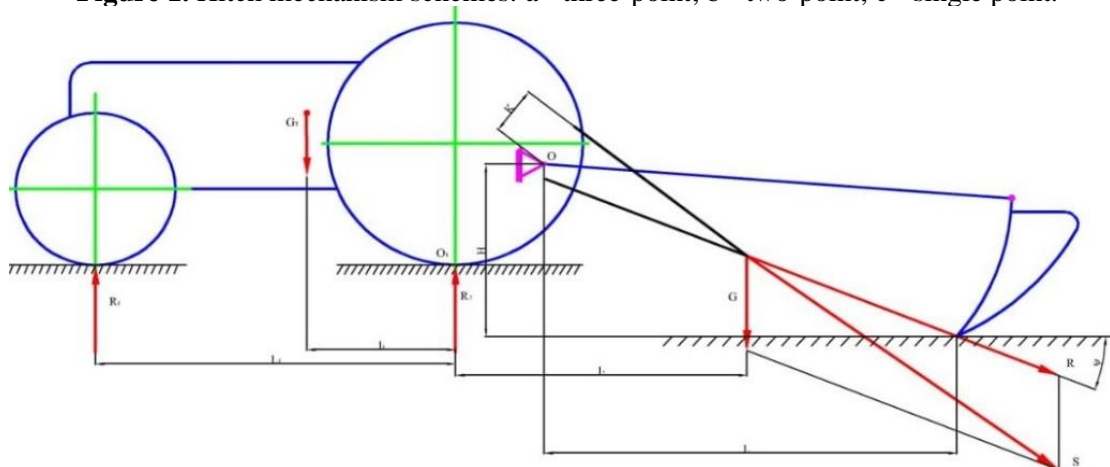

**Figure 2.** Scheme of the action of forces on the working bodies of the cultivator with a single-hinge system.

A two-point connection is also used, when the D<sup>1</sup> hinges are brought together (Fig. 1, b) and a single-point connection, which are not connected with the upper link and have only one-point D<sup>1</sup> (Fig. 1, c) [8, 9].

### 4. Stability of the stroke of the working bodies of the cultivators of the existing industrial design

Furrow cutters and cultivator tines are fixed to the frame rigidly or with hinges. The rigid connection is the simplest: it is used with cultivators for continuous soil cultivation. The articulated joint is more complicated, but it ensures that the field contours are followed, and, consequently, the accuracy of soil cultivation at a given depth. Connections can be single-hinged, in which the amount of movement of the working bodies is associated with a change in the angle of entry of the paws (or furrow cutter) into the

soil, and multi-joint (parallelogram), in which the angle of entry of the furrow cutter into the soil remains constant.

The depth and stability of the furrow cutter in a single-joint system (Fig. 2) depends on the dimensions  $H$  and  $L$ , the weight  $G$  of the cultivator and the reaction  $R$  of the soil. Deepening is possible if the torque from the action of external forces relative to point  $O$  has a positive value. The most output is a system in which the deepening of the working bodies and their balance in the working position are provided only by the resultant force  $S$  without additional vertical loads. To prevent protrusion of the working body, the dimensions  $H$  and  $L$  are selected so that the moment  $SK$  remains positive even at the minimum values of the angle  $\psi$ .

The depth and stability of the stroke of the working bodies in the multi-hinged system (Fig. 3) depends on the angle  $\alpha$  of the installation of the four-link link relative to the horizontal (or dimensions  $h$  and  $X$ ) and does not depend on the height of the section suspension point and the length of the beam. The system will be in equilibrium if the direction of the force  $S$ , transferred parallel to itself to point  $B$ , coincides with the direction of link  $AB$ . When the direction of the force  $S$  changes, equilibrium can be achieved by changing the height  $h$  of the four-link bar. The penetrating moment can be increased by means of a compression spring. In mounted cultivators, the value of the sinking moment is adjusted by changing the position of the instantaneous center of rotation of the system, which is achieved by lowering or increasing the point of attachment to the tractor of the central link of the mounted device (Fig. 4) or by changing the height of the cultivator's trailer post. With such a control system, the values of  $H$  and  $L$  can vary within significant limits. With an additional vertical load for deepening, it is necessary that the torque  $SK > 0$  [10, 11].

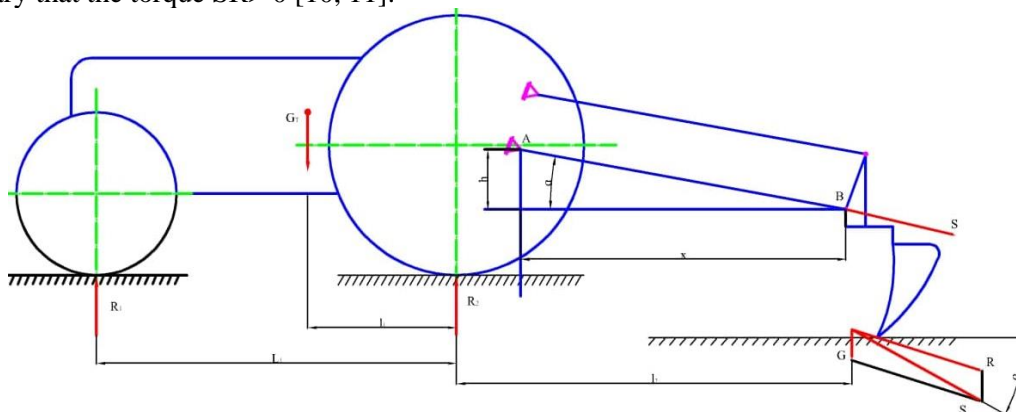

**Figure 3.** Scheme of the action of forces on the working organs of the cultivator with a multi-hinge (parallelogram) system

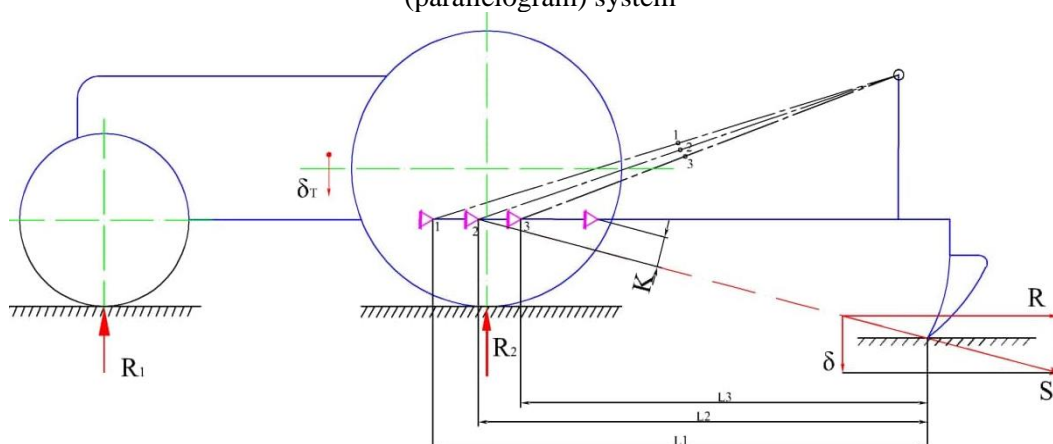
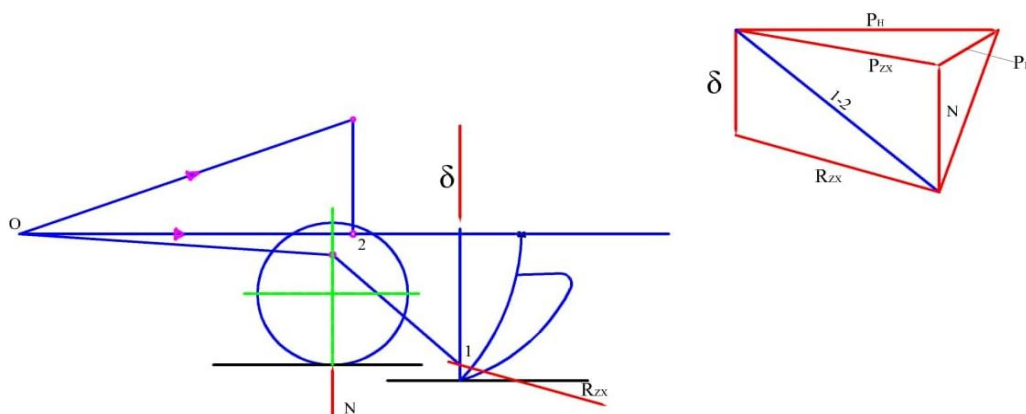

**Figure 4.** Scheme of the action of forces on the working organs of the cultivator (1, 2, 3 - points corresponding to different positions of the section).

Lifting mechanisms of the cultivator. The transfer of the cultivator from the working position to the transport position and vice versa is carried out using a mechanical or hydraulic drive. Automatic machines with a mechanical drive were used on trailed cultivators. Currently, such cultivators are equipped with external hydraulic cylinders powered by the tractor hydraulic system. The device for installing an external hydraulic cylinder on the cultivator instead of a mechanical automatic machine consists of a pivot shaft with levers, a link and a bracket for the cylinder. The use of external hydraulic cylinders on cultivators contributes to an increase in labor productivity and a decrease in the weight of cultivators [12, 13].

Lifting and deepening of mounted cultivators connected to the tractor using a three-point hinged system is carried out by the tractor's hydraulic lift.

The known forces acting on the mounted cultivator (Fig. 5) are its weight  $G$  and the reaction of the soil  $R_{zx}$  to the working bodies, and the unknown are the reaction  $N$  on the rim of the support wheels and the forces:  $P_B$  in the upper link of the linkage mechanism and  $P_H$  in the lower links. Geometric addition of forces using the force polygon method allows you to find these unknown forces. To do this, draw a straight line parallel to the resultant forces  $G$  and  $R_{zx}$  through point 1 of the intersection of the directions of the forces  $G$  and the reaction of the soil  $R_{zx}$ , until it intersects with the direction of the force. The resulting point 2 will be connected to the point of the trailer  $O$ , and in the power polygon we will draw a line parallel to the direction 2-0, intersection with the direction of force  $N$ . The intersection point determines the values of  $N$  and the traction force  $R_{zx}$ , at which the system will be in equilibrium. Expanding the force  $R_{zx}$  in the direction of the links, we find the magnitude of the efforts  $P_B$  and  $P_H$  acting in these links [14].



**Figure 5.** Diagram of the forces acting on the lifting mechanism of the mounted cultivator

As can be seen from the above, the existing furrow makers do not always meet the requirements of agricultural technology. According to theory, these machines should copy the depth set by the driver, relative to the planned surface of the field, i.e. the longitudinal profiles of the bottom of the cut furrow and the surface of the earth must be parallel. To obtain these values, the surface of the irrigated field must be ideally planned. To achieve such an accuracy of the field surface is not only costly and resource intensive, but also practically impossible. In addition, it should be noted that even when the ideal leveling of the daytime surface of the field is achieved, the marks of the bottom of the furrow may differ.

Since the existing furrow cutting machines are not able to meet the agro technical requirements, all furrow cutting units are mounted.

Our research has shown and verified that when the machine is moving during cutting, the furrows are strongly deflected. The slightest deviations of the basic tractor drastically change the parameters of the cut furrows, since all elements of the furrow cutter are pivotally attached and hinged to the tractor [15].

According to the proposed technology, the process of cutting furrows along a given slope of their bottom should be performed automatically. It is impractical to install automation on a mounted machine. The working body (furrow cutter and compactor) must have independent control and support, regardless of the movement of the trajectory of the base tractor. Therefore, it is considered inappropriate to use existing furrow cutting machines for cutting furrows with the installation of automation.

The use of this proposed device for the formation of profiled furrows, i.e. cutting furrows along a given slope and compaction of the soil in their beds with the formation of the design section and longitudinal profile of the furrow in one pass will save costs on planning work, since it allows you to increase the permissible deviation for the leveling of the field surface. On the sections of the cut furrows, using the new technology and the proposed devices, uniform soil-soil moisture is provided along the entire length of the furrows, both in depth and in area. This, in turn, has a positive effect on the saving of irrigation water, which is the main resource in conditions of their acute shortage [16].

## 5. Conclusions

A database has been created for the mechanization of existing technologies and technical means of cutting furrows along a given slope and compaction of soil in their beds with the formation of a design section and a longitudinal profile of a furrow on the lands of farms in arid zones.

A project of technological maps for the production of cutting grooves with a given slope and with a variable density of their bed, taking into account the granulometric and volumetric composition of the lumps, has been drawn up.

A methodology for technological and economic assessments of the selected schemes for cutting furrows with a given slope and variable density of their bed has been developed.

Recommendations have been developed for the mechanization of cutting furrows with a given slope and with a variable density of their stock of farm lands and a technical requirement for the machine.

## References

- [1] Decree of the President of the Republic of Uzbekistan dated February 7, 2017. № PF-4947 "Strategy of action on five priority directions of development of the Republic of Uzbekistan in 2017-2021".
- [2] The Decree of the President of the Republic of Uzbekistan № PP-3405 November 27, 2017. "On the State Program of Irrigation and Irrigation of Irrigated Lands for 2018-2019". Tashkent.
- [3] Berdyansky V.N, Atajanov A.U, July 30, 1997. Methods of obtaining the excitation. *Initial Patent* **1114**. No. 4.
- [4] Copyright certificate of the Republic of Uzbekistan No. IHDP 9600689.1. (19) UZ (11) 4619 B. (51) 6A 01 G 25/00 1996
- [5] Cultivator-plant feeding cotton universal KHU-4. 1988. *M. GOSNITI*,
- [6] Bashta T 1974 Volumetric pumps and hydraulic hydraulic motors *Mechanical Engineering* pp 496-97
- [7] Atajanov A 2021 *Technology and technical means to create a stable profile and design slope of irrigation canals* (TIAME Publishing House)
- [8] Matyakubov B Sh 2003 *Reports of the international scientific-practical conference. Tashkent. Tashkent Agrarian University*, pp 153-155.
- [9] Matyakubov B Sh 2020 *Journal of Agricultural Science* **9** 27-29
- [10] Atajanov A, Khudaev I, Usmanov N and Babajanov L 2021 *E3S Web of Conferences* **264** 04005
- [11] Babajanov L, Sharipov Z, Khakimov B, Badalov S and Sobirov E 2021 *E3S Web of Conferences* **264**, 04040
- [12] Matyakubov B and Aynakulov Sh 2019 *Certificate from the Intellectual Property Agency on application in educational process DGU 2019 0899*.
- [13] Begmatov I 2019 "Agro ilm" magazines. - Tashkent, **1** (57) 74-75
- [14] Ergashev R, Bekchanov, F, Atajanov A, Khudaev I and Yusupov F 2021 *E3S Web of Conferences* **264** 04026

- [15] Bekchanov F, Yusupov F, Kholbutaev M, Khayitov B and Ulashov O 2021. *IOP Conf. Series: Earth and Environmental Science* **868** 012039
- [16] Rakhimbaev F, Hamidov M and Bespalov F 1992 *Characteristics of irrigation of agricultural crops in the Amu Darya sheep* (T.: Science)