



TOSHKENT IRRIGATSIYA VA QISHLOQ  
XO'JALIGINI MEXANIZATSIYALASH  
MUHANDISLARI INSTITUTI



**FAN:**

•Elektrlashtirishni  
kompleks loyihalash

**MAVZU**

•Loyixalarda quvvat koeffitsiyentini  
kompensatsiyalash



Turdibayev Abduvali  
Abdjalolovich



Elektrotexnologiyalar va  
elektr jihozlaridan  
foydalanish kafedrası



# *Reja:*

1.

- **Elektr energiyasining reaktiv tashkil etuvchilari**

2.

- **Reaktiv quvvatni kompensatsiyalash usullari**

3.

- **Kondensator batareyalarini qoʻllashda yuzaga keluvchi texnik noqulaylik**

# Elektr energiyasining reaktiv tashkil etuvchilari

Elektr ta'minoti tizimida elektr uzatish liniyalari va iste'molchi yuklamalarining aktiv qarshiligi bilan birgalikda induktiv va sig'im ham bo'ladi

Induktiv tok iste'mol qurilmalari reaktiv quvvat (energiya) qabul qiluvchilar deb

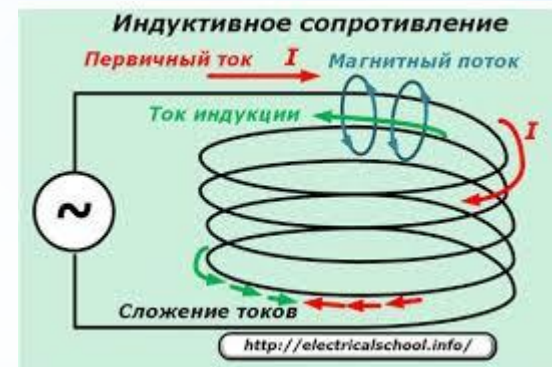

sig'im tok iste'molchi qurilmalari esa reaktiv quvvat (energiya) manbasi deb ataladi.

Reaktiv quvvat iste'molchilarini tarkibini taxlil qilish shuni ko'rsatadiki, asosiy reaktiv quvvat iste'molchilar to'rt xil ko'rinishdagi qurilmalardan

asinxron dvigatellar 40%



elektr isitgichlar 8%



transformatorlarni hamma turi  
35%,



elektr uzatish liniyalari (ularda  
isroflar) 7% tashkil qiladi



Elektr tarmoqqa kuchlanish berilganda aktiv-induktiv yuklamada tok bu kuchlanishdan burchakka siljib orqada qoladi

$$u = U_m \sin \omega t$$

$$I_{\text{H}} = I_m \sin(\omega t - \varphi)$$

$$P = UI \cos \varphi = I^2 R$$

$$Q = UI \sin \varphi = P \operatorname{tg} \varphi$$

Elektr qabul qiluvchi aktiv hamda reaktiv quvvatni iste'mol qiladi

Har ikki holatda joriy quvvat koeffitsiyenti

$$\cos \varphi = \frac{P_i}{Q_i} = \frac{P_i}{\sqrt{P_i^2 + Q_i^2}}$$

Elektr energiyasi iste'molchilarning aktiv, reaktiv quvvatlari nafaqat oraliq vaqt muddatida balki ishlab chiqarish bir smenasi o'tishda o'zgarib turadi

Reaktiv quvvat koeffitsiyenti aktiv quvvatda reaktiv quvvat ulushini yaqqol ko'rsatadi

$$\operatorname{tg} \varphi = \frac{Q_i}{P_i}$$

$$\cos \varphi = \frac{1}{\sqrt{1 + \operatorname{tg}^2 \varphi}}$$

Koeffitsiyentlar orasidagi aloqa

Elektr energiyasining aktiv quvvat iste'molchilarining iste'mol qiladigan aktiv quvvati ish bajaradi va boshqa tur energiyaga: mexanik, issiqlik yorug'lik kimyoviy, siqilgan xavo energiyasi va gazga o'zgaradi



Reaktiv quvvat elektr qabul qiluvchi qurilmalarda foydali ishga bajarmasdan elektrodvigatel, transformator va elektr uzatish liniyalarida elektromagnit maydon hosil bo'lishiga sarflanadi.

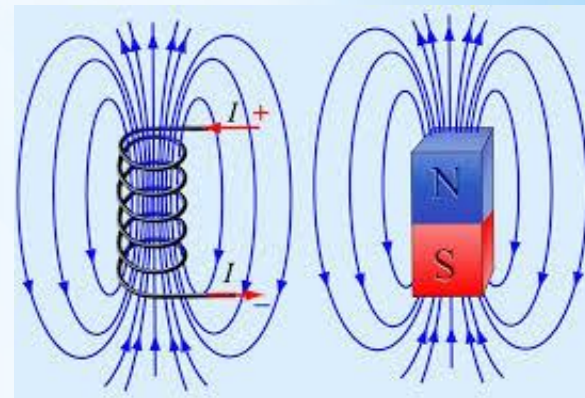

Energiya tarmog'ini 100% reaktiv quvvatining 22% elektrostansiyalarni kuchaytirish transformatorlarida

energiya tarmog'ini 110-750kV li podstansiyalardagi kuchlanishni oshiruvchi avtotransformatorlarida, 6,5%

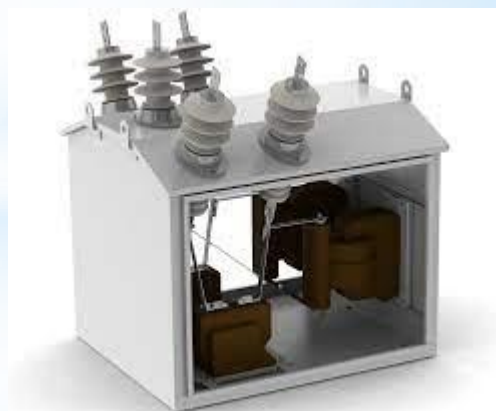



tuman elektr tarmoqlarida, 13,5%  
kuchlanish pasaytiruvchi  
transformatorlari

58% esa 6-10kV shinalaridagi  
iste'molchilarning reaktiv quvvatni  
yo'qolishidan hosil bo'ladi



Elektr ta'minot tizimining R qarshiligi orqali aktiv R va reaktiv Q  
quvvati uzatilishida aktiv quvvat yo'qotish quyidagicha bo'ladi

$$\Delta P = \frac{P^2 + Q^2}{U^2} R = \frac{P^2}{U^2} R + \frac{Q^2}{U^2} R = \Delta P_a + \Delta P_p$$



Tuman elektr tarmoqlarida qo‘shimcha kuchlanish isrofi paydo bo‘ladi. Aktiv R va reaktiv X qarshilikli elektr ta‘minot tarmoqlari orqali aktiv quvvat R va reaktiv quvvat Q uzatishda kuchlanish yo‘qotish

$$\Delta U = \frac{PR + QR}{U} = \frac{PR}{U} + \frac{QP}{U} = \Delta U_a + \Delta U_p$$

## Reaktiv quvvatni kompensatsiyalash usullari

**Reaktiv quvvatni kompensatsiyalash deb uni ishlab chiqarish yoki kompensatsiyalash qurilmalari yordamida iste‘mol qilishga aytiladi**

Ma'lumki kondensatorlardan o'tayotgan tok unga quyilgan kuchlanishdan  $90^\circ$  burchakka oldinda bo'lib.

induktiv g'altakda o'tuvchi tok esa unga quyilgan kuchlanishda  $90^\circ$  burchakka orqada qoladi

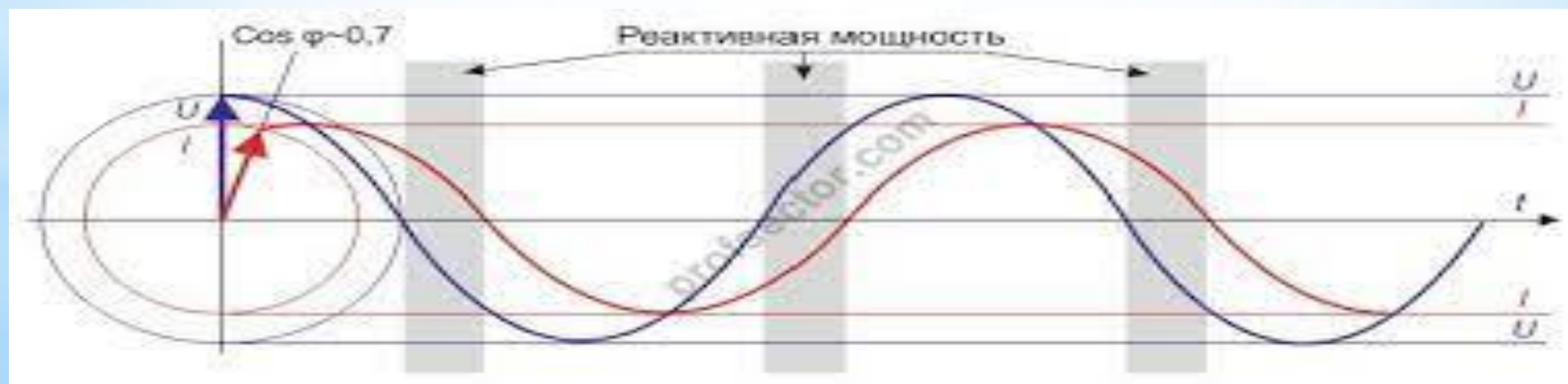
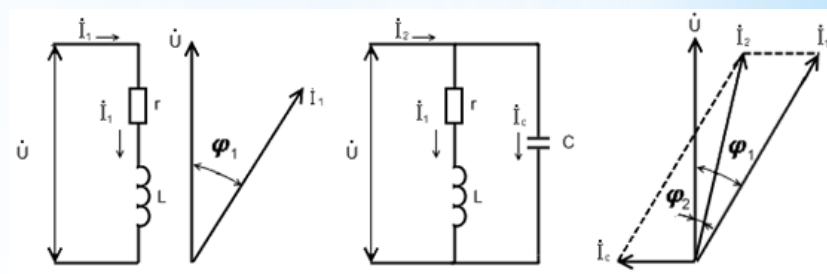
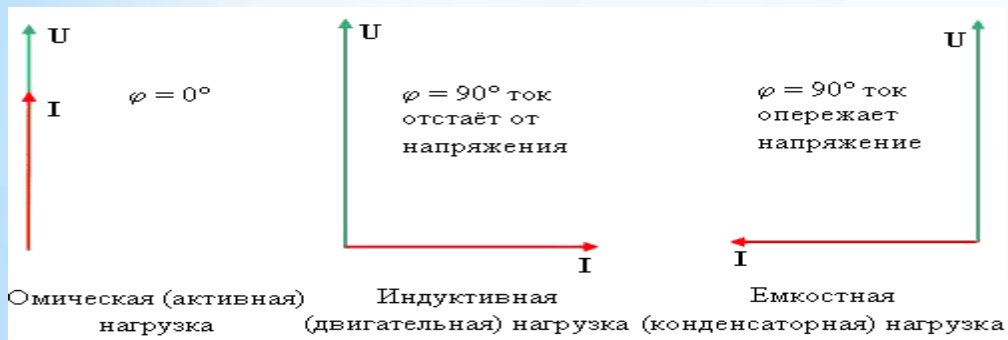

Reaktiv quvvatni kompensatsiyalash muhim texnik tadbir bo‘lib, bir qancha maqsadlarda qo‘llash mumkin

**Birinchidan** reaktiv quvvatni kompensatsiyalash reaktiv quvvat balansini ta‘minlash uchun zarur



**Ikkinchidan** kompensatsiya qurilmalarini qo‘llash tarmoqda elektr energiya isrofini kamaytirish uchun

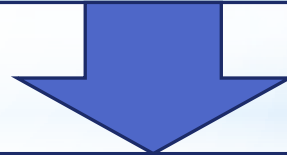

**Uchinchidan** kompensatsiya qurilmalari kuchlanishlarni rostdash uchun qo‘llaniladi

# Reaktiv quvvatni balansi va uning tarmoq kuchlanishi bilan bog'liqligi

$$\Sigma Q_r = \Sigma Q_{ист} = \Sigma Q_{юкл} + \Sigma \Delta Q$$

bu yerda:

$\Sigma Q_r$  - generatorlar ishlab chiqarayotgan reaktiv quvvatlarning yig'indisi, kVar;

$\Sigma Q_{ист}$  - iste'mol bo'layotgan reaktiv quvvatlarning yig'indisi, kVar;

$\Sigma Q_{юкл}$  - reaktiv yuklanishlarning yig'indisi, kVar;

$\Sigma \Delta Q$  - reaktiv quvvatlarning isrofi, kVar.



Reaktiv quvvatlarning balansi bajarilganda energetik tizimida kuchlanish ma'lum bir miqdorda saqlanadi. Reaktiv quvvatini balansi buzilishi bilan tarmoqdagi kuchlanish o'zgaradi.

$$\Sigma P_r > \Sigma P_{ucm}$$

bo'layotgan bo'lsa, tarmoqdagi kuchlanish oshadi

$$\Sigma P_r < \Sigma P_{ucm}$$

bo'layotgan bo'lsa, tarmoqdagi kuchlanish pasayadi

Elektr stansiyalarida ishlab chiqarilayotgan reaktiv quvvat yetarli emas.

Shuning uchun iste'molchilarga kerak bo'lgan reaktiv quvvatini  $2/3$  qismi kompensatsiyalovchi qurilmalar yordamida



$1/3$  qismi elektr tarmoqlardan olinadi.

Kompensatsiyalovchi qurilmalarni (kondensator batareyalari) o'rnatish bilan liniyadagi kuchlanish yo'qolishi kamayadi

$$\Delta U = [\Sigma PR + (\Sigma Q - \Sigma Q_{kk})X] / U$$

bu yerda:  $R, X$  – liniyaning aktiv va reaktiv qarshiligi;

$\Sigma R$  - liniyadagi aktiv quvvatlarning yig'indisi, kVt;

$\Sigma Q$  - liniyadagi reaktiv quvvatlarning yig'indisi,  
kVar;

$\Sigma Q_{kk}$  - kompensatsiyalovchi qurilmalarning reaktiv quvvatlari yig'indisi, kVar.

Kuchlanishni nominal miqdoriga nisbatan o'zgarishi yuklanish grafiki bilan bog'liqdir.

Hisobiy aktiv  $P_{xuc.}$  va reaktiv  $Q_{xuc.}$  yuklanishlar borligida kuchlanish yo'qolishi quyidagi formula bilan aniqlanadi

$$\Delta U\% = \frac{P_{xuc.} R + Q_{xuc.} X}{10U_{НОМ}}$$

Agarda tarmoq uzunligi  $l$ , simlarning qarshiliklari  $r_0$  va  $x_0$  ma'lum bo'lsa

$$\Delta U\% = \frac{(r_0 + x_0 \operatorname{tg} \phi) P_{xuc.} l}{10U_{НОМ}^2}$$



Reaktiv quvvat iste'moli natijasida asinxron motorda aylanuvchi magnet oqim hosil bo'ladi va bu oqim yordamida statordan rotorga kerakli miqdorda aktiv quvvat ko'chiriladi



Shuning bilan birgalikda reaktiv quvvat iste'mol qilinishining salbiy ta'sirlari bor

- Qo'shimcha yuklangan transformator va liniyalarni quvvat o'tkazish qobiliyati pasayadi

- Elektr iste'molchilarga quvvat yetkazishida elektr tarmoqlarda quvvat va energiya isroflari oshib ketadi:

$$\Delta P = \frac{P^2 + Q^2}{U^2} R_{\text{тармоқ}} + \frac{P^2}{U^2} R_{\text{тарм}} + \frac{Q^2}{U^2} R_{\text{тарм}}$$

## Quvvat koeffitsiyentini oshirish usullari

Kondensator batareyasining quvvati tarmoq kuchlanishiga nisbatan ikkinchi darajasida va sig'imga nisbatan birinchi darajasida to'g'ri proporsionaldir

$$\Sigma Q_{\kappa} = 3U_{\text{тарм}}^2 \omega c 10^{-3}$$

bu yerda:  $\Sigma Q$  - uch fazaga qo'shilgan kondensator batareyalarning quvvati, kvar;

$U_{\text{тарм}}$  – tarmoqning kuchlanishi, kV;

$\omega$  - burchak chastotasi, S-1;

$S$  – kondensator batareyasining sig'imi, mkF.

Tarmoqning chastotasi  $f=50$  Gts ligini hisobga olganda, yuqorida keltirilgan formulaning ko‘rinishi o‘zgaradi:

$$\Sigma Q_{\kappa} = 0,942 U_{\text{max}}^2 C$$

Quvvat koeffitsiyentini oshirish uchun qo‘llaniladigan kondensator batareyasining quvvati quyidagi formula yordamida aniqlanadi:

$$\Sigma Q_{\kappa} = \Sigma P (tg \varphi_1 - tg \varphi_2)$$

bu yerda:  $\Sigma P$ - qurilmalarning aktiv quvvati, kVt;  
 $\varphi_1$  va  $\varphi_2$  - kondensatorsiz va kondensatorli fazalarning burchak og‘ishi

Hamma hollarda kompensatsiya qurilmalar qo‘llashda quyidagi texnik va rejim talablarini chegaralarini o‘rganish zarurdir

1) yuklama tugunlarida zaruriy quvvat zaxirasini



2) manbaning shinalarida reaktiv quvvatni joylashtirish



3) kuchlanish og‘ishini



4) elektr tarmoqlarni o‘tkazish qobiliyati

Reaktiv quvvatni kompensatsiyalash uchun olib boriladigan tadbirlarni quyidagi 3 ta guruxga ajratishimiz mumkin

1. Kompensatsiya qurilmalarni talab qilmaydiganlarni qoʻllash



2. Kompensatsiya qurilmalarni qoʻllaydiganlar



3. Istisno tariqasida ruxsat etilgan

Kompensatsiya qurilmalar qoʻllashdagi tadbirlar.

- 1) statik kondensatorlarni oʻrnatish.
- 2) sinxron dvigatellarni kompensator sifatida qoʻllash.
- 3) reaktiv quvvatni statik manbalarni qoʻllash.
- 4) parallel ishlovchi takidlab oʻtilgan bir necha qurilmalarni kompensatsiya tarmoqi uchun qoʻllash.

# kompensatsiya qurilmalarini joylashgan o‘rinlarini bir necha turi ko‘rinishi

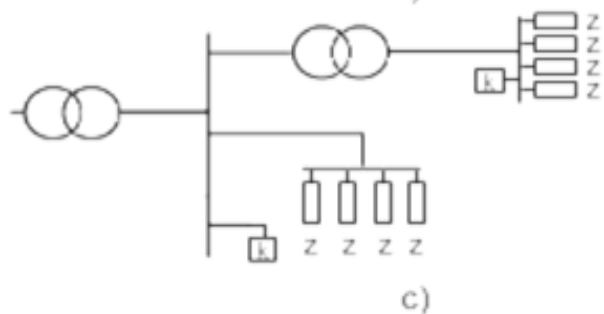
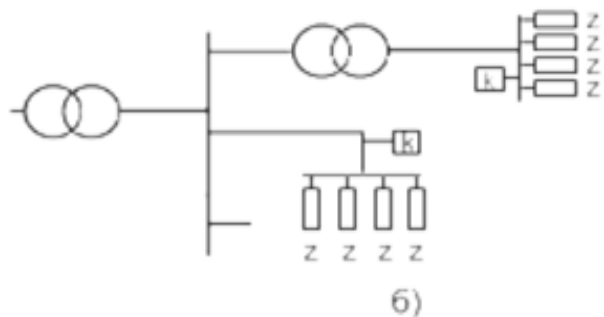
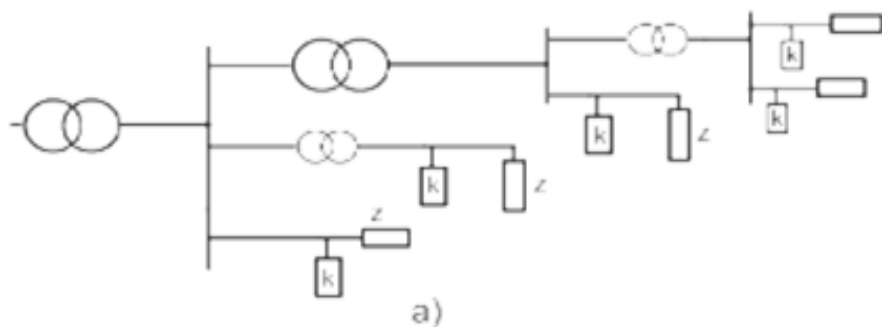

## Reaktiv quvvatni kompensatsiyalashdagi kondensator batareyalarini qo'llashda yuzaga keluvchi texnik noqulaylik

Kompensatsiya uchun kondensator batareyalaridan foydalanish ayniqsa keng qo'llaniladi



Qat'iyat bilan aytiladiki ularni yuqori va past kuchlanishlarga mosligi kichik aktiv quvvat iste'moli ( $0.0025-0.005\text{kVt/kVar}$ ) eng kam solishtirma narxini (1kVar uchun), oddiy ekspulatatatsiyasi; oddiy ishlab chiqarish montaji; har qanday quruq binolarda o'rnatilishiga mosligi bu ularning eng katta avfzaliklaridir.

Ammo nochiziq yuklamalarda paydo bo‘ladigan yuqori garmonikalari bo‘luvchi tarmoqlarda, oddiy reaktiv quvvatni kompensatsiyalovchi qurilmalarni qo‘llashda ayrim texnik noqulayliklarga ega

Kondensatorda o‘ta yuklanish toklari 30% gacha, kuchlanish esa 10% gacha oshirishga ruxsat beriladi. Amalda esa rezanans hisobiga yuklama toki 400%-500% gacha yetish mumkin.

V	Kondensator		Stablizator		Kompensatsiyalovchi reaktor		
	Turi	kvar	Turi	Nom.tok A	Turi	Nom.tok A	L, mGn
0	TKRM 6,3/6	6,3	PSM -6,3/6	335	RKOM -	335	23,6
	TKRM 12,5/6	12,5	PSM -	670	3800/6	670	11,7
	TKRM 20/6	20	12,5/6	1060	RKOM -	1060	7,5
			PSM - 20/6		7500/6 RKOM- 12600/6		
0	TKRM 6,3/10	6,3	PSM -	200	RKOM -	200	67
	TKRM 12,5	12,5	6,3/10	400	4000/10	400	33,5
	TKRM 20/10	20	PSM - 12,5/	630	RKOM -	630	21,5
	TKRM 40/10	40	PSM -	1250	7800/10	1250	10,6
			20/10		RKOM -		
			PSM -		12500/10		
		40/10		RKOM -			
				24500/6			





Рис. 193. Схемы присоединения конденсаторных установок в сети 6—10 кВ (а), в сети до 1000 В (б—г) и при индивидуальной компенсации (д)



№ п/п	Название	Мощн. Qном. квар	Ток, Iном. А	Габариты (ВхШхГ), мм У3/У1	Вес, кг У3/У1	Цена с НДС, руб.
<b>КОНДЕНСАТОРНЫЕ УСТАНОВКИ УКМ 58 (нерегулируемые)</b>						
1	УКМ 58-0,4-10 У3(У2,У1)	10	14	800x440x270/900x440x270	28/31	<a href="#">узнать цену</a>
2	УКМ 58-0,4-15 У3(У2,У1)	15	22	800x440x270/900x440x270	28/31	<a href="#">узнать цену</a>
3	УКМ 58-0,4-25 У3(У2,У1)	25	36	800x440x270/900x440x270	30/33	<a href="#">узнать цену</a>
4	УКМ 58-0,4-50 У3(У2,У1)	50	72	800x440x270/900x440x270	32/35	<a href="#">узнать цену</a>
5	УКМ 58-0,4-75 У3(У2,У1)	75	108	800x440x270/900x440x270	36/39	<a href="#">узнать цену</a>
6	УКМ 58-0,4-100 У3(У2,У1)	100	144	800x440x270/900x440x270	38/41	<a href="#">узнать цену</a>
7	УКМ 58-0,4-125 У3(У2,У1)	125	180	1150x600x450/1250x600x450	48/52	<a href="#">узнать цену</a>
8	УКМ 58-0,4-150 У3(У2,У1)	150	216	1150x600x450/1250x600x450	50/54	<a href="#">узнать цену</a>

## \* MAVZUGA OID FOYDALANGAN ADABIYOTLAR RO'YXATI

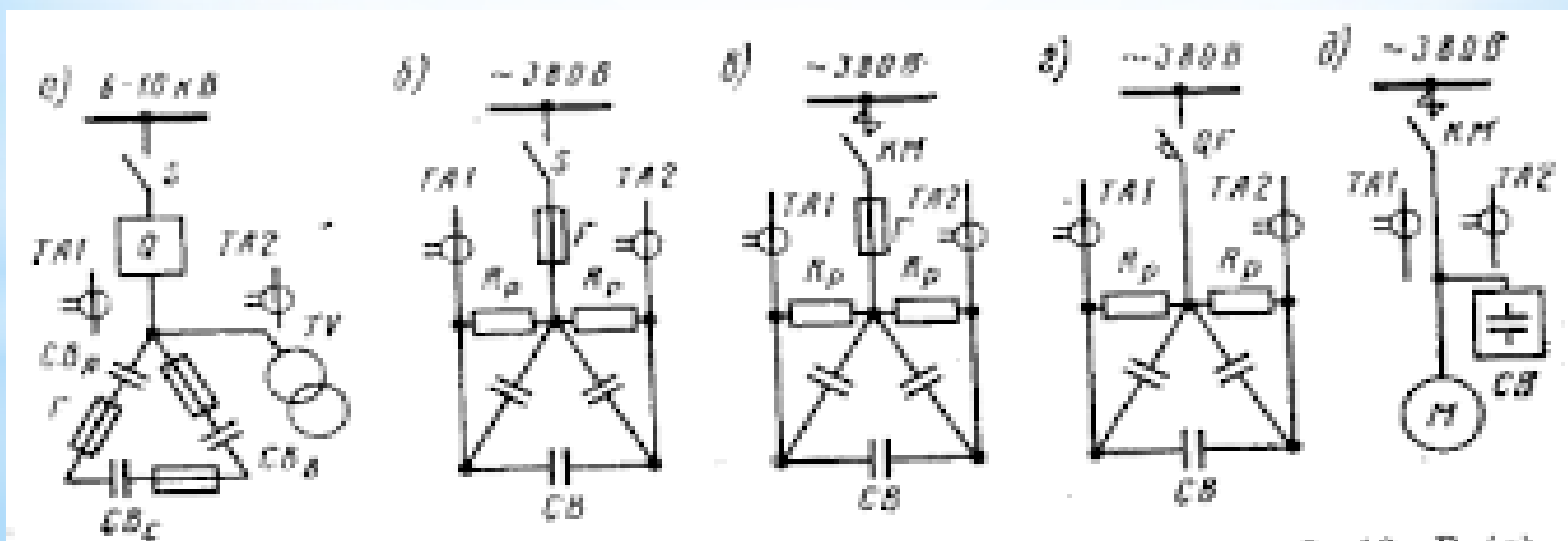
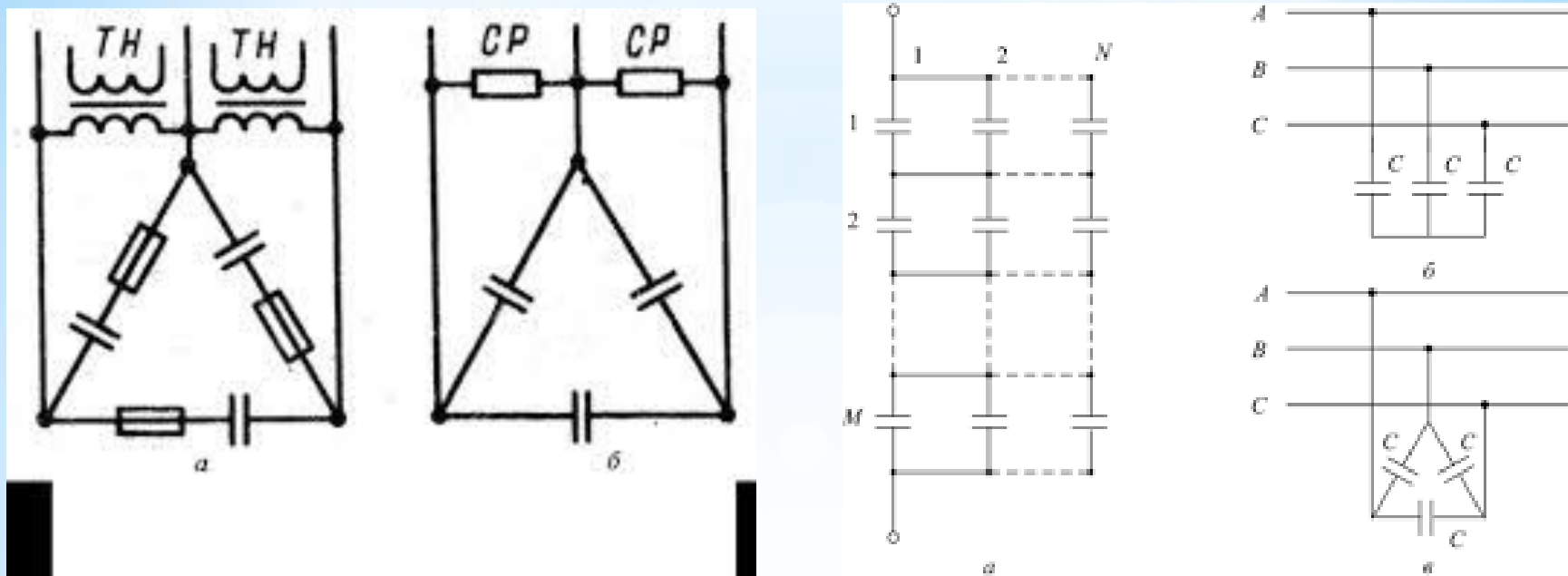
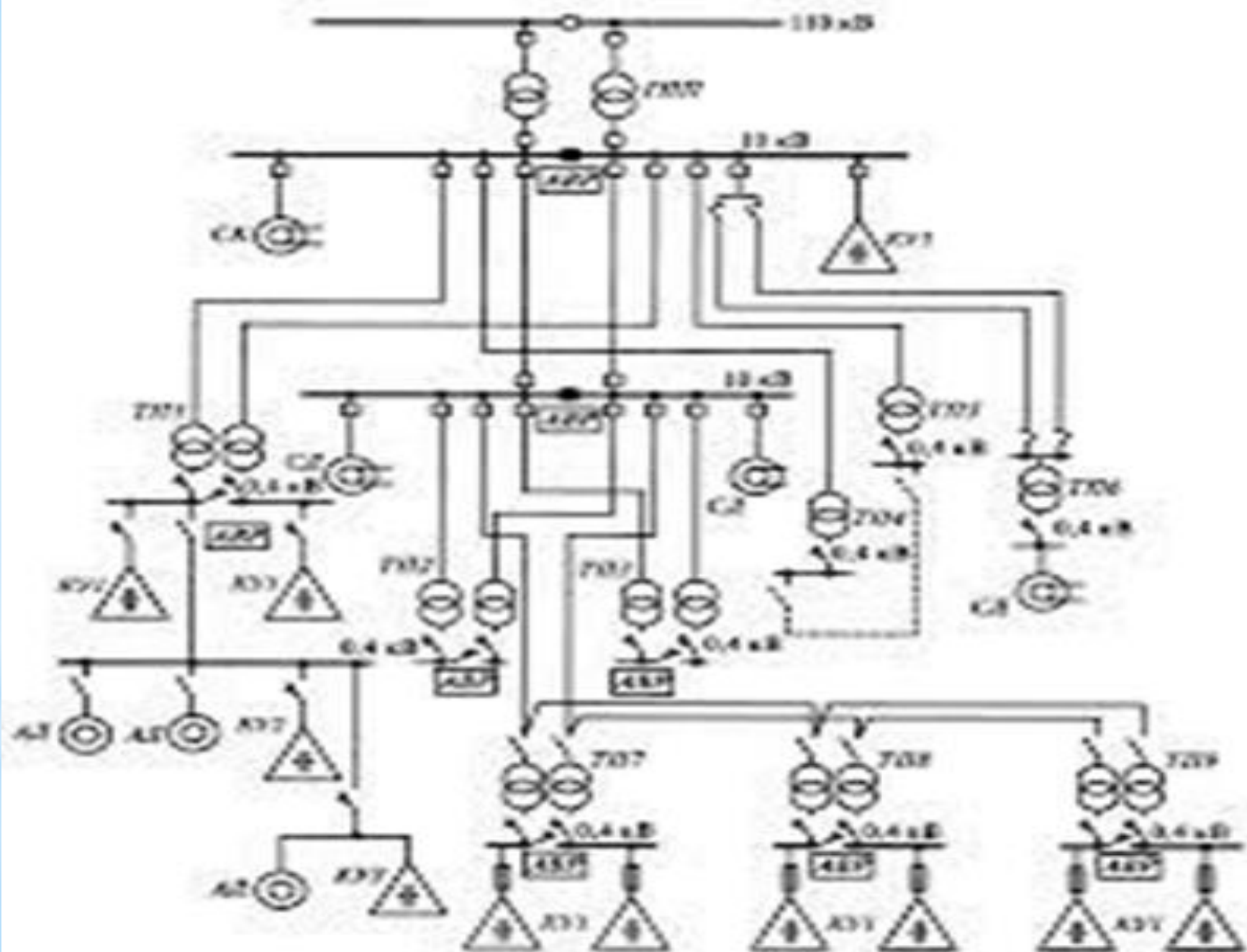
- \* 1. . Detlef Lucius. Planning of Electric Power Distribution. Technical Principles. Siemens AG. Germany. 2015.
- \* 2. Williams T Armstrong 2000, 'EMC for Systems and Installations', Newnes ISBN 0-7506-4167-3
- \* 3. Тошпўлатов Н.Т “Электр тизимларини лойихалаш” ўқув қўлланма- Т.: ТИМИ, 2013-й, 322б.
- \* 4. А.Я.Змеев Проектирование систем электрификации: [учебное пособие для вузов по специальности "Электрификация и автоматизация сельского хозяйства"]. СГАУ, 2010. 151
- \* 5. В. М. Расторгуев Проектирование систем электрификации.учеб.пособие для студентов вузов, обучающихся по специальности 311400 - "Электрификация и автоматизация сел.хоз-ва" / В. М. Расторгуев М-во селхоз-ва Рос. Федерации, Департамент кадровой политики и образования, Рос. гос. аграр.заоч.ун-т. - М. Рос. гос. аграр.заоч.ун-т, 2004. – 128 с.
- \* 6. Пособис к курсовому и дипломному проектированию для электроэнергетических специалистов. под ред. В.М. Блок. Москва Высшая школа 2002 г. 285 С.
- \* 7. А. Раджабов, М. Ибрагимов, А.С. Бердишев. Энергия тежамкорлик асослари. Тошкент ТИМИ 2009 й. 152 бет.
- \* 8. А. Раджабов, М. Ибрагимов. Қайта тикланувчи энергия манбалари ва фойдаланиш технологиялари. Тошкент. ТИҚХММИ 2019й. 407 бет



TOSHKENT IRRIGATSIYA VA QISHLOQ  
XO'JALIGINI MEXANIZATSIYALASH  
MUHANDISLARI INSTITUTI



**E'TIBORINGIZ UCHUN RAHMAT!**



Turdibayev Abduvali  
Abdualolovich



Elektrotexnologiyalar va elektr  
jihazlaridan foydalanish  
kafedrası



+ 99899-521-35-83



turdiboev1983@mail.ru