

PAPER • OPEN ACCESS

## Influence of the thickness of the roller discs of the combined machine on the indicators of their work during the processing of plowed lands afterwards

To cite this article: A K Igamberdiev *et al* 2022 *IOP Conf. Ser.: Earth Environ. Sci.* **954** 012001

View the [article online](#) for updates and enhancements.

You may also like

- [Reply to 'Comment on "On the stability of a bicycle on rollers"'](#)  
Patricia A Cleary and Pirooz Mohazzabi
- [Atomic force microscopy based manipulation of graphene using dynamic plowing lithography](#)  
Borislav Vasi, Markus Kratzer, Aleksandar Matkovi et al.
- [Assessment of a miniature four-roll mill and a cross-slot microchannel for high-strain-rate stagnation point flows](#)  
Farzan Akbaridoust, Jimmy Philip and Ivan Marusic



245th ECS Meeting • May 26-30, 2024 • San Francisco, CA

[Learn more & submit!](#)

Present your work at the leading electrochemistry & solid-state science conference.

Network with academic, government, and industry influencers!

Submit abstracts by December 1, 2023



# Influence of the thickness of the roller discs of the combined machine on the indicators of their work during the processing of plowed lands afterwards

A K Igamberdiev<sup>1</sup>, D K Muqimova<sup>2</sup>, E Z Usmanov<sup>1</sup>, Sh D Usmanova<sup>3</sup>

<sup>1</sup> Tashkent Institute of Irrigation and Agricultural Mechanization Engineers, 39, Kari-Niyaziyave., Tashkent, 100000, Uzbekistan

<sup>2</sup> Andijan Machine-Building Institute, 56, Boburshoxave., Andijan, 170019, Uzbekistan

<sup>3</sup> Tashkent State Technical University Named After Islam Karimov, 2, Qatartol street, Tashkent 100097 Uzbekistan

E-mail: asqar1959i@mail.ru

**Abstract.** Under the conditions of the Republic, when plowing the soil after harvesting winter wheat or re-crops, the upper layer containing plant residues and weeds is turned over and dumped into the lower layer, and as a result, voids and irregularities are formed in the arable layer. Proceeding from this, an industrial copy of the combined machine used in the preparation for planting of new plowed lands was developed in cooperation with Andijan agricultural and agrotechnologies, as well as Andijan machine-building institutes. The article presents the impact of the thickness of the discs of this combined machine disc rollers on the working performance of the device, and it is noted that the thickness of the combined machine rollers should be 22-25 mm in order to ensure quality processing at the required level, while consuming less energy on ploughed lands.

## 1. Introduction

Introduction. Particular attention is paid to the reduction of Labor and energy consumption in the agricultural production of the Republic, the saving of resources, the cultivation of agricultural crops on the basis of advanced technologies and the development and application of high-performance agricultural machines. In 2017-2021 in the strategy of actions on further development of the Republic of Uzbekistan, in particular, the tasks of "...further improvement of the meliorative state of irrigated lands for modernization and rapid development of agriculture, development of networks of melioration and irrigation facilities, introduction of intensive methods in the sphere of agricultural production, first of all, modern agrotechnologies that save water and resources, In the implementation of these tasks, including all technological processes for the preparation of new plowed land for planting(complete condensation of the plow layer, leveling the surface part of the field.

## 2. Analysis of the current state of the problem under consideration and references to sources.

In our country, such crops as vegetables and potatoes, which are sown as a repeated crop to the fields that are sown in the open field, are sown on fresh, that is, directly to the plowed lands before planting.



Land plowed in the Bush is prepared for izma-izma planting, and then planting activities are carried out.

At present, the preparation for planting of new arable land is carried out on multiple times separately by means of gears (BZTX-1,0; BZTS-1,0; BZSS-1,0) and disc (TDB-3,0; BDT-3,0) rakes and various trowel-levers (MV-6, MV-6,5, VP-8). But this leads to a deterioration of the physical and mechanical properties of the soil, numerous loss of moisture from the soil, as well as increased side costs and other costs.

The analysis of the scientific and technical achievements achieved on a global scale as well as the studies carried out in our Republic [4-6] shows that the existing shortcomings in the preparation of new plowed lands for planting can be eliminated by the development of a machine that performs all technological processes (full condensation of plowed field, leveling and crushing of the surface). The use of such a machine in pre-sowing processing on newly plowed lands allows to increase the work productivity, improve the quality of soil processing, as well as prevent the loss of moisture in it, timely sowing and harvesting of crops, with a sharp reduction in the consumption and other costs, taking into account the addition of technological processes and the reducing [7-9]. Due to this, in cooperation with Andijan agricultural and agrotechnologies and Andijan machine-building institutes, a combined machine consisting of disc rollers, rollers and Planetary rollers installed in the common frame was developed for use in the preparation of new plowed lands for planting (Figure 1).

From theoretical premises, the main consequence of nanopowder introduction into the melt should be refinement of the macro- and microstructure, as the powder particles must serve as nuclei of new grains. Figures 1 and 2 show photos of the microstructure of cast samples from the bronze of the lead-tin bronze grade, both modified by SDP of aluminium oxide and without modifier addition. The phase composition of the bronze under study represented in photos of the microstructure is a solid solution of tin in copper, lead inclusions and eutectoid inclusions based on electron compound.

### 3. Method of dissolution.

The economic efficiency of the combined machine used in izma-track processing on new ploughed lands Rd en 63.03-98 determined on "Testing of agricultural machinery. Methods for calculating the economic efficiency of the tested agricultural machinery" and theoretical mechanics, peasant mechanics, laws and regulations of Mathematical Statistics, Mathematical planning of experiments and methods of tensometry were used in the research process and existing normative documents (TSt 63.04:2001, TSt 63.03.2001) were used (Figure 1).



**Figure 1.** The combined machine used in the processing of new plowed field.

### 4. Results analysis and examples

The thickness of the discs was determined using the following expression, which was derived from the condition that they were fully used on the working surfaces of the wedge parts [11-15] (Figure 2).

$$t \leq 2h_{T\min} \operatorname{tg} \gamma, \quad (1)$$

Where  $h_{T\min}$  – the minimum immersion depth of the discs in the soil, m;  
 $\gamma$  – half of the angle of the disc sharpening, grad

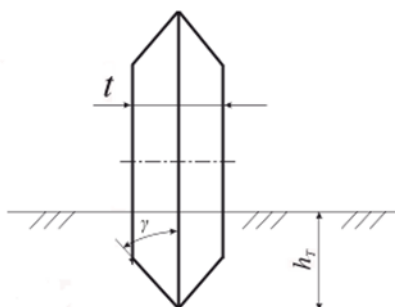

**Figure 2.** Scheme for determining the thickness of the wedge disc.

When the (1) condition is fulfilled, the wedge-shaped, that is, the sharpened parts of the discs are fully immersed in the soil, and this means that their working surfaces fully participate in the process of work (Figure 2) [16; 17].

It turns out that the thickness of the discs of the rollers can be as many as 5,8 cm, if by expression  $h_{T\min} = 5$  cm and  $\gamma = 30^\circ$ .

This means that the thickness of the combined machine coils should be no more than 5,8 cm, in order to ensure quality processing at the required level, while consuming less energy on the plowed lands.

In the experiments, the thickness of the spool discs was taken from 17,5 mm to 25,0 mm and changed with an interval of 2,5 mm. Here the experiments were conducted at 6,7 and 8,3 km/h movement speeds.

The results obtained in the experiments are presented in Table 1 and 3-6 pictures. Their analysis shows that with an increase in the thickness of the discs of the rollers, the quality of the soil's smoothing has improved, that is, in the layer of 0-10 cm the size is greater than 100 mm and the number of fractions in the range of 100-50 mm has decreased, while the size of fractions smaller than 50 mm. For example, at 6,7 km/h movement speed, the thickness of the roller discs increased from 17,5 mm to 25,0 mm, the size was greater than 100 mm, and the fractions in the range of 100-50 mm decreased by 4,8 and 4,3 percent respectively, while the smaller fractions in the size 50 mm increased by 9,1, at a speed of 8,3 km/h, these indicators amounted to 4,1; 5,5 and 9,6 percent, respectively. Here it should be noted that with an increase in the thickness of the discs, the fractions whose size is greater than 100 mm and in the range of 100-50 mm are reduced, and the intensities of fractions smaller than 50 mm are reduced. For example, when the thickness of the discs increased from 17,5 mm to 20,0 mm, the size was greater than 100 mm, and the number of fractions in the range of 100-50 mm decreased by 1,5-1,8 and 2,1-2,4 percent, respectively, and when the size of fractions smaller than 50 mm increased by 3.9 percent, these indicators were respectively 0.3-0.9, 2.4-2.7 and 2.5-2.6 foizni when increased from 22.5 mm to 25.0 mm.

With an increase in the thickness of the roller discs, the improvement in the quality of soil smoothing occurs mainly on account of the increase in the zone of their impact on the soil, that is, the volume of soil affected by the discs increases.

With an increase in the thickness of the discs, the density of the soil in layers 10-20 and 20-30 cm increased. For example, when the thickness of the discs increased from 17,5 mm to 25,0 mm, the density of the soil in layers of 10-20 cm and 20-30 cm at the speed of movement of 6,7 km/h increased

respectively to 0,05 and 0,07 g/cm<sup>3</sup>, and at the speed of movement of 8,3 km/h to This also occurs mainly on account of the increase in the zone of impact of the discs on the soil.

Due to the above reasons, the increase in the thickness of the roller discs from 17,5 mm to 25 mm led to an increase in their specific gravity resistance from 1,16 kN/m at a speed of 6,7 km/h to 1,04 kN/m, and at a speed of 8,3 km/h to 1,08 kN/m.

Here, too, an increase in the speed as above has led to an improvement in the quality of soil erosion, a decrease in density and an increase in the comparative resistance to gravity. In the 3-6 pictures, graphs of the change in the degree of soil evaporation, that is, the size of which is smaller fractions than 50 mm, depending on its density and the thickness of the discs of the comparative resistance to gravity, are presented.

**Table 1.** Table 1. Laboratory-field device performance changes depending on the thickness of the spool discs

№	Name of the indicators	Thickness of discs, mm							
		17,5		20,0		22,5		25,0	
Values of indicators									
1.	Movement speed, km/h	6,7	8,3	6,7	8,3	6,7	8,3	6,7	8,3
2.	Soil smoothing quality (the amount of fractions of the following size), %								
	>100 mm	5,7	4,6	3,9	3,1	1,8	0,8	0,9	0,5
	100-50 mm	17,6	16,1	15,5	13,7	15,0	13,0	13,3	10,6
	<50 mm	76,7	79,3	80,6	83,2	83,2	86,2	85,8	88,9
3.	Density of soil in the following layers, g/cm <sup>3</sup> :								
	10-20 cm	1,10	1,09	1,12	1,11	1,14	1,13	1,15	1,14
	20-30 cm	1,12	1,10	1,14	1,13	1,17	1,15	1,18	1,16
4.	Comparative resistance to gravity, kN/m	1,04	1,08	1,09	1,12	1,13	1,16	1,16	1,18

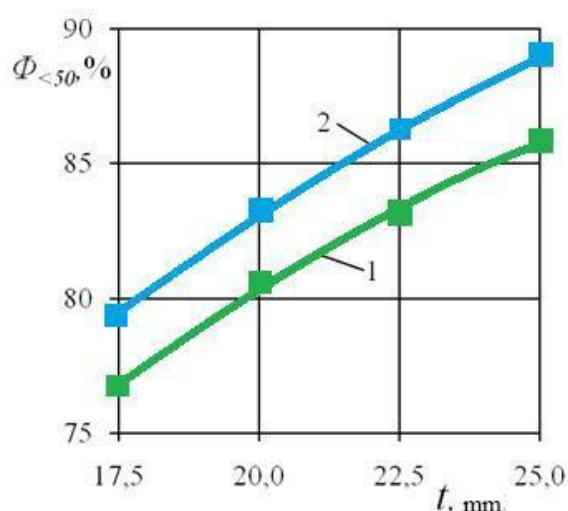

1, 2-when the movement speed is 6, 7 and 8,3 km/h respectively

**Figure 3.** Graphs of changes in the degree of soil evaporation ( $\Phi_{<50>}$ ) depending on the thickness (t) of the discs of the rollers.

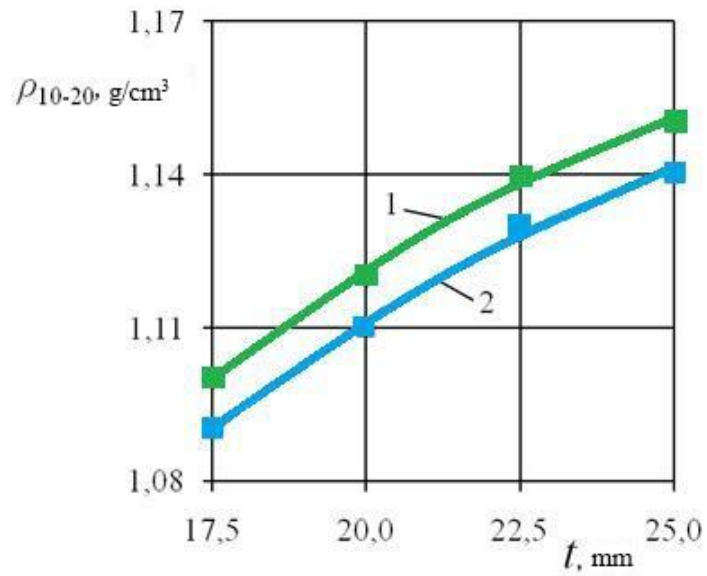

1, 2-when the movement speed is 6, 7 and 8,3 km/h respectively

**Figure 4.** Graphs of the change in the density of the soil in the layer of 10-20 cm ( $\rho_{10-20}$ ) depending on the thickness ( $t$ ) of the discs of the coils.

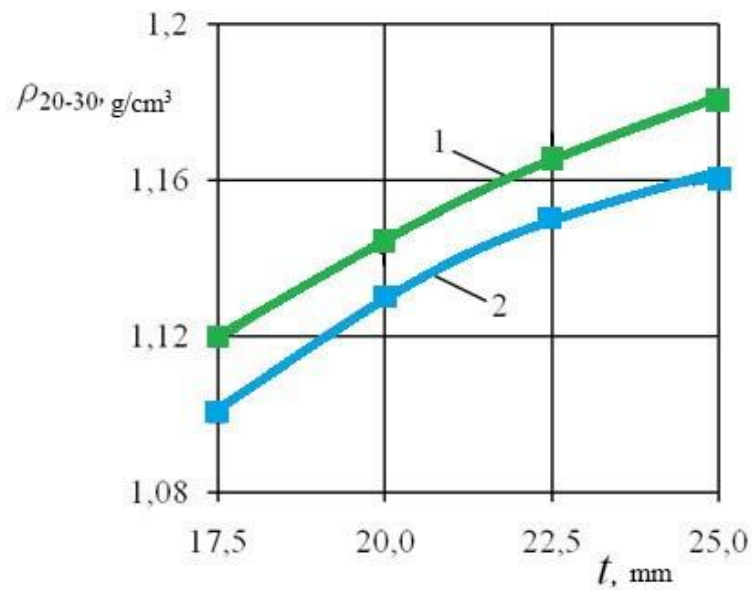

1, 2-when the movement speed is 6, 7 and 8,3 km/h respectively

**Figure 5.** Graphs of the change in the density of the soil in the layer of 20-30 cm ( $\rho_{20-30}$ ) depending on the thickness ( $t$ ) of the discs of the coils.

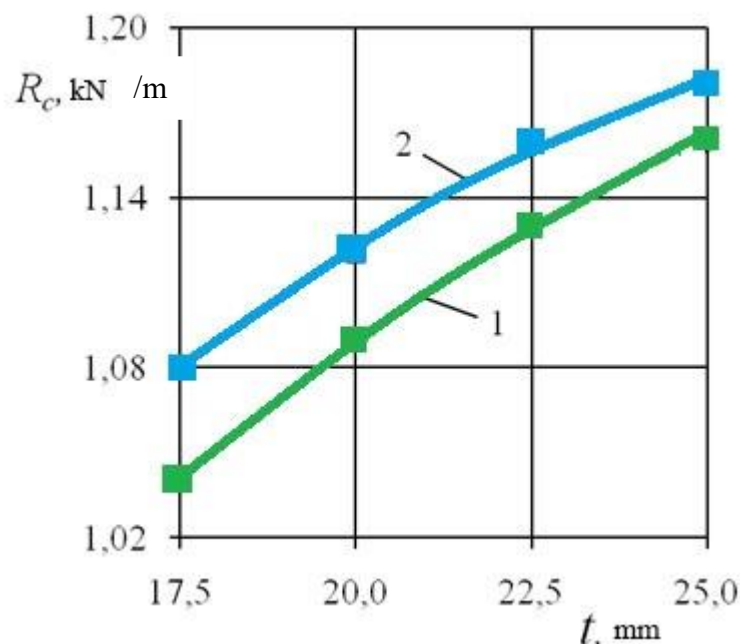

1, 2-when the movement speed is 6, 7 and 8,3 km/h respectively

**Figure 6.** Comparative resistance  $R_c$  of coils to traction graphs of changes depending on the thickness ( $t$ ) of their discs.

(3) - (6) as can be seen from the pictures, all the indicators were adjusted (increased) according to the legislation of the bubble parabola, depending on the thickness of the spool discs, and their change (increase) intensity was reduced by increasing the thickness of the discs.

## 5. Conclusion

According to the calculations and conducted experiments on the obtained expressions, the thickness of the discs of the combined machine coils should be 22-25 mm in order to ensure quality processing at the required level with low energy consumption of plowed lands at the speeds of 6.0-8.0 km/h of the coils.

## Acknowledgments

The reported study was researched of Andijan Institute of Agriculture and agrotechnologies I-2016-2-26/1 it was carried out within the framework of the projects" preparation and introduction into production of industrial copies of the combined machine for preparing land for planting " (2016-2017).

## References

- [1] Imomkulov K B, G'aybullayev B Sh, Mukimova D K 2014 *A collection of articles of the Republican scientific-practical conference dedicated to the 50th anniversary of Andijan Agricultural Institute*. (Andijan: AAI) pp 235-236
- [2] Mukimova D K 2014 *Collection of articles of the Republican scientific-practical conference on the topic of effective use of resurstejamkor technologies in the cultivation of agricultural products and modernization of production of environmentally friendly products*. (Andijan, AAI) pp 121-123
- [3] Akbarov Kh U, Abdujabborov O A, Shokirov Kh, Mukimova D K 2017 *Collection of materials of the ministry-wide scientific and technical conference "problems of innovative development: production, Education, Science"* (Andijan, AndMI) pp 35-36
- [4] Akhmedov A A, Mirsaidov A R 2012 *Problems of implementation of innovative ideas, technologies and projects in production: Collection of scientific papers of the IV Republican*



- Scientific and Technical Conference* (Tashkent: Printing House of the center of Science and technology) pp 71-72
- [5] Tukhtakuziyev A, Ergashev M M 2016 *Scientifically based systems of dry farming in modern conditions. Materials of the international scientific and practical conference* (Volgograd: FGBOU VPO Volgograd GAU) pp 343-345
- [6] Tukhtakuziyev A, Ergashev M M 2017 *Agriculture of Uzbekistan* **8** 29-30
- [7] Mamatov F M, Ravshanov H A 2019 *International scientific-practical conference "Science, Education and innovation, problems and prospects for agro-industrial complex"* (Tashkent) pp 249-252
- [8] Mamatov F M, Ravshanov H A 2010 *Materials of the Republican scientific-practical conference "Prospects of development of technical and technological service in agriculture"* (KarMII. Karshi) pp 271-273
- [9] Mamatov F M, Chuyanov D Sh, Ergashev G X 2015 *Innovation technologies* **4** 51-54
- [10] 1998 RD Uz 63.03-98 Testing of agricultural machinery. Methods for calculating the economic efficiency of the tested agricultural machinery **49**
- [11] Imomkulov K B 2017 *To create and increase the level of use of highly efficient agricultural machinery.* (Gulbakhor: QXMEI) pp 125-129
- [12] Mukimova D K 2020 *Namangan Engineering and Technology Institute scientific and technical journal*, **5 (2)** 211-216
- [13] Mukimova D K 2020 *International scientific-practical conference package on "modern problems of Science, Education and production in innovative development"* (Andijan: AndMBI) pp 535-541
- [14] Xadji-Muradov A O, Nuriddinov A 2004 *Materials of the Republican scientific – practical conference on the topic Of the most important problems of Modern science and technology* pp 243-247
- [15] Imomkulov K B, Mukimova D K 2018 *Fergana Polytechnic Institute "scientific-technical" journal Fergana* **1(22)** 148-150
- [16] Tukhtakuziyev A, Imomkulov K, Mukimova D, Karimov A 2016 *Collection of articles of the Republican scientific-practical conference "effective use of advanced agrotechnologies in the cultivation, storage and processing of agricultural products: problems and solutions"* (Andijan AAI) pp 264-268
- [17] Igamberdiev A K, Muqimova D K 2020 *Journal of Irrigation and Melioration. Tashkent* **3(21)** 67-72