

Improvement of the state of degraded pastures by mechanized sowing of shrubs and semibrubs

Erkin Farmonov^{1*}, Parakhat Berdimuratov¹, Bakhadir Kuybakov², Shakhnoza Mirzaeva¹, Dauran Djumamuratov³

¹“Tashkent Institute of Irrigation and Agricultural Mechanization Engineers” National Research University, Tashkent, 100000, Uzbekistan

²Almalyk branch of Tashkent State Technical University named after Islam Karimov, 110100 Almalyk, Uzbekistan

³Karakalpak Institute of Agriculture and Agrotechnologies, Abdambetov Street, Nukus 230100, Republic of Karakalpakstan, Uzbekistan

Abstract. This article presents the extensive agricultural characteristics of fodder plants growing wild in nature, which are the most promising shrub and semi-shrub fodder plants for the creation and development of cultivated pastures in degraded karakul (sheep) pastures. Also, the fact that out of 17.5 million hectares of land allotted for karakul breeding in the desert and semi-desert zones of the Republic, which up to 40 percent are degraded to one degree or another, their average productivity has decreased by 21 percent. The authors of the article analyzed degraded pastures in desert and semi-desert zones of Uzbekistan and foreign countries and ways to improve their condition. A method is recommended for restoring degraded pastures by mechanizing the sowing of seeds of shrubs and semi-shrubs. Studies on the mechanization of sowing small-seeded and non-flowing seeds show that, firstly, the mechanized sowing of desert fodder plants is largely carried out on the basis of agrotechnical methods in conditions that do not correspond to the specific conditions of deserts, and secondly, shrub and semi-shrub plants and their seeds have physical and mechanical properties that are very different from other crops and seeds. A universal sowing unit is recommended, which consists of a four-sowing machine, which, in one pass of the technological process of work, sows seeds of shrubs and semi-shrub desert fodder plants with relatively close seed sizes. At the same time, the hoppers of the sowing unit are filled with 1, 2, 3 or 4 types of seeds of different plants and the seeds are sown. During the operation of the unit, the first hopper of the sowing machine is filled with shrub seeds (for example, saxaul) and the hoppers of the remaining 2, 3 and 4 sowing machines are filled with one or different types of seeds of semi-shrubby plants (Izen, keiruk, teresken), etc. The universal sowing machine sows seeds in one direction 3.6 m wide, and when returning, it also sows seeds 3.6 m wide, forming a pasture strip with a total width of 7.2 m. In the first row, it sows the seeds of a shrub plant (for example, saxaul seeds) and, in the remaining 2, 3, 4 rows - different types of seeds of semi-shrubs, for example, seeds of izen or seeds of other semi-shrubs, while on both edge rows of the pasture strip, he sows seeds of shrubs between them, sows seeds of semi-shrubs and creates a pasture-protective strip, consisting of shrubs and semi-shrubs. Simultaneous sowing of shrubs along the two edges of the strip provides for the protection of these undersized semi-shrubs from heat, strong wind and dust, as a result of which they develop better. The following parameters of the universal seeding unit were determined: the speed of movement of the unit is 1.38 -2.22 m/s; working width of the universal sowing unit 3.6 m; quantity of the sowing device 4 pieces; distance between sowing units 0.9 m; the number of seed mixture mixers in the lower part of the hopper is 6 pieces; lengths of cone-shaped fingers softeners of the seed mixture 7.0 cm; normalizing drum radius 5.0 cm; number of revolutions of the normalizing drum 26-30 r/min; length of the normalizing drum 7.0 cm; quantity of triangular chute 8 pieces.

1. Introduction

The Decree of the President of the Republic of Uzbekistan “On measures for the comprehensive development of the karakul breeding industry” increased the forecasts of parameters for 2019-2021: the number of karakul sheep up to 7346 thousand, wool production up to 11403 tons, production of karakul skins up to 1256.6 thousand pieces and the area of seed production of steppe pasture plants up to 8400, and in 2022 it is planned to export 31600 pieces of astrakhan skins, 632 tons of meat and 316 kg of "Thymus" for the production of unique drugs for medicine.

* Corresponding author: Erkinfarmonov2009@mail.ru

Desert and semi-desert pastures in Uzbekistan 32 million hectares of which 20.6 million hectares are natural pastures. 17.5 million hectares of which are allocated for animal husbandry. The natural vegetation of these pastures is the main source of food for desert livestock. The use of natural pasture forage plants in desert animal husbandry is economically beneficial, since all types of animals consume 95-100 percent of their nutrients from natural pastures, as a result of which they receive cheap and high-quality products (meat, milk, skins, skins and wool, etc). Leather, including karakul skins, is a valuable raw material, in demand in unlimited quantities in our country and in foreign countries. As industry experts note, karakul and meat-wool sheep breeding is the unity of an expedient and cost-effective means of agricultural development of desert and semi-desert territories [1, 2, 3, 4, 5].

Pasture fodder plants are subdivided into shrubs, semi-shrubs and tree forbs.

In order to improve pastures, scientific institutions of Central Asia and Kazakhstan tested about 300 species of shrubs, semi-shrubs, annual and perennial fodder plants collected from the natural flora of arid regions in order to improve the condition of pastures by scientists and specialists of the Research Institute of Animal Husbandry and Desert Ecology, Institute of Botany of the Academy of Sciences of the Republic of Uzbekistan, research institutes of the Russian Federation related to this area. After testing, 25-30 species were selected and recommended for use by promising plants for improving pastures, in terms of productivity, drought resistance. Literature provides information about the economic suitability of shrubs and semi-shrubs for improving degraded pastures [5, 6, 7, 8, 9, 10].

Shrubs. Black saxaul (*Haloxylon aphyllum*) is a large tree-like shrub. It grows in the desert of Central Asia and Kazakhstan. Belongs to the number of fast-growing shrubs. In the first year it grows to one and a half meters in height, in 4-5 years - 2-3 meters. Grows up to 30 years or more. The eaten part of the saxaul is assimilation shoots and fruits. The fodder mass yield under natural growing conditions is up to 10 centners/ha, and under culture conditions up to 16 centners/ha. Black saxaul is promising for creating shrub-semi-shrub pasture-protective plantations in astrakhan farms.

Palecki's Circassian (*Salsola paleczkiana*) and Richter's Circassian (*Salsola richteri*) are large shrubs. Palecki's Circassian in the conditions of the piedmont wormwood-ephemeral desert in the first year of life reaches 145 cm, in the second 176.2 centimeters. Circassian, like black saxaul, along with great opportunities for afforestation and sand fixation, is a valuable fodder plant. The yield of fodder mass of Cherkezov pastures with ephemera varies within 6-8 c/ha of air-dry mass.

It can be used when creating shrub-semi-shrub pasture-protective plantations. It is also used for fixing sands and when creating pasture-protective plantations.

Chogon (*Aellenia subaphylla*) is a shrub 75-150 cm high, characterized as a fast growing and highly productive plant. Vegetates 180-220 days a year, is an excellent fodder in the autumn-winter season for karakul sheep and all year round for camels. Chogon forms up to 23.2-27.5 centners/ha of air-dry mass. Promising for the creation of pasture-protective plantations of shrub-semi-shrub fodder lands.

Kandym (*Calligonum* L) is a shrub 40-300 cm high. Sheep eat well in spring and summer as a succulent fodder. In culture, plants develop quite quickly. The yield of air-dry mass is high - 9-16 q/ha. It is well eaten by sheep, goats and camels in spring and summer. It is used to fix sands and create shrub and semi-shrub plantations in the sandy desert.

Semishrubs. Izen (*prutnyak*) (*Kochiaprostrata*) - a shrub 35-75 cm high, is a valuable fodder plant, readily eaten by sheep in all seasons of the year. The growing season in the first year is 220-280 days. Researchers note its vigorous growth, due to which it gives large yields of fodder mass in the first year, and in subsequent years the yield increases even more. Izen harvest reaches 15-22 c/ha of air-dry weight. Based on the ecological conditions of growth and morphological features, three ecotypes of izen are distinguished: sandy, stony and clayey. All ecotypes of Izen are valuable and promising.

Keyreuk (*Salsola arentalis*) is a heavily pubescent shrub up to 50-70 cm high. It is a highly valuable food for sheep and camels in all seasons of the year, especially in autumn and winter. In the foothill semi-desert, its harvest in the second and third years reaches 19 c/ha. Researchers characterize it as a promising plant for creating long-term pastures, both in the foothill semi-desert and in the sagebrush-ephemeral desert of Uzbekistan.

Keyreuk is a promising fodder plant for creating shrub and semi-shrub lands for autumn-winter, year-round use in the desert zone with a draft of 100-300 mm.

Wormwood (*Artemisia diffusa*), Turanian wormwood (*Artemisia turanica*), salt-loving wormwood (*Artemisia halophila*) - shrubs 30-40 cm high. Wormwood and Turanian are common on desert non-saline gray-brown and sierozem soils.

Salt-loving wormwood grows on saline soils. Wormwood is a good pasture for Karakul sheep, especially in autumn and winter. The duration of vegetation is 230-240 days. The yield of wormwood on natural pastures ranges from 1.0 to 7.0 q/ha of air-dry mass. In culture, wormwood forms relatively high yields of fodder mass (6.5 - 7.9 q/ha).

A promising plant for creating shrub-semi-shrub plantations and fodder lands, especially on saline lands.

Teresken (*Kraschennikovia eversmanniana*) is a semi-shrub up to 50-55 cm high. It grows in Kyzylkum and Syrdarya region, mainly in dry riverbeds filled with deposits of fine gravel and sand. A good all-season fodder plant. The duration of the growing season is 200-220 days. Grows well in culture. The fodder mass yield in the third-sixth years reaches 4.5-6.0 c/ha of air-dry fodder mass.

Teresken is a promising plant when created to create pasture-protective plantations and shrub-semi-shrub lands on the piedmont plains and in the foothills.

Camphorosma (*Camphorosmalesingii*) is a shrub 25-80 cm high. It grows on solonchaks and moderately saline soils. Highly nutritious fodder plant for sheep and camels. The vegetation period is 235 days. The yield of natural pastures is 2.0-3.0 c/ha. Camphorosma in culture grows and develops quite quickly. The yield of its air-dry mass is 8-12 q/ha. A promising plant in the creation of shrub-semi-shrub lands on saline soils of deserts and semi-deserts.

Bluegrass bulbous- (*Poa bulbosa* L.) is a perennial, sod-forming ephemeroïd from the grass family. The bushes of the plant are erect, 35-40 cm high. The leaves are narrow-linear, 5-7 cm long, 0.2-0.3 cm wide. Leafiness is 78-80%. The length of the growing season is 118-124 days. The yield of green fodder mass reaches 8-10 c/ha, hay - 5-6 c/ha. Highly nutritious feed for all types of farm animals. One kilogram of bluegrass feed contains up to 1 feed unit.

2. Materials and Methods

Among the shrub and semi-shrub fodder plants growing in their natural wild form in desert and semi-desert zones, the shrub-semi-shrub with the indicated characteristics is the most promising for creating a pasture and improving pasture-protecting plantations. Their choice depends on the specific conditions and improvement technology.

The future development of the industry depends mainly on a stable source of feed. Unfortunately, the fodder productivity of pastures does not yet meet the needs of the existing animal population. Valuable species of useful plants disappear. At present, there are large degraded areas in almost all parts of the desert pastures of our republic. 40 percent of desert pastures experienced varying degrees of pasture degradation and their average productivity decreased by 21 percent. Currently, about 8.0 million degraded pastures in the republic need improvement [5, 7, 11]. According to the scientific conclusions of experts, one of the main methods for the radical improvement of desert and semi-desert natural pastures is their constant renewal by sowing local perennial wild-growing shrubs and semi-shrubs. It has been established that when cultivating pastures by sowing naturally growing fodder plants, their productivity can be increased by 10-15 times compared to natural pastures [12, 13].

However, improving degraded pastures is not an easy task. To do this, it is necessary to prepare degraded areas and high-quality seeds of desert fodder plants, to mechanize the sowing process. The complexity of the problem lies in the fact that seeders used for sowing other crops cannot be directly used to mechanize the sowing of seeds of desert fodder plants.

The fight against pasture degradation and increasing their productivity by sowing promising natural wild-growing desert fodder plants is currently carried out on the basis of agricultural practices that are not suitable for specific conditions. There is no generally accepted exact set of machines for desert pastoralism.

Therefore, one of the main tasks is to create a seeder that meets the agrotechnical requirements for the mechanized sowing of seeds of desert-pasture plants.

Based on the need to combat the degradation of natural arid pastures and increase their productivity, most research institutes and individual researchers of the republics of Central Asia and the Russian Federation, as well as foreign researchers, are conducting scientific research on the mechanization of sowing small-seeded and non-flowing seeds. The studies proposed a number of experimental seeders and their modernized devices in order to solve the problem of increasing productivity and combating the degradation of productive plants of natural pastures by sowing and reseeded them on degraded pastures [15, 16, 17, 18, 19, 20].

3. Results and Discussion

From the presented analytical data on the sowing of seeds of desert fodder plants in desert zones, it can be seen that there is still no generally accepted set of machines for desert-pasture animal husbandry. One of the main reasons for this is that the mechanized sowing of desert fodder plants is mainly carried out on the basis of other agrotechnical methods that are not suitable for the specific conditions of deserts and semi-deserts, and the second is the physical and mechanical properties of desert fodder plants and their seeds, a sharp difference in physical - mechanical properties from other crops and seeds. Fineness of seeds, difficulty in sieving and non-flowing, low density, low purity of seeds (no more than 20-25 percent), high content of plant residues and other foreign elements in the seed

mixture, as well as the presence of wings in the seeds and their slight damage make them problematic mechanized sowing.

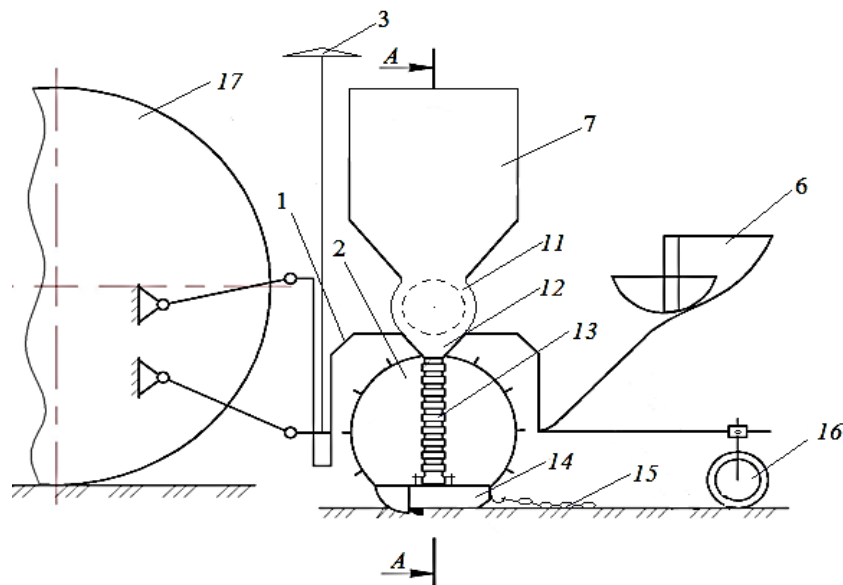

Fig. 1. Scheme of the universal seeding unit, side view

Given the need to improve the condition of desert pastures and combat their degradation, it is necessary to mechanize their sowing, in particular, to develop and introduce seeders.

Based on the need for mechanization of sowing seeds of desert fodder plants, we have developed seeders for sowing seeds of desert fodder plants [21, 22, 23]. Also, a universal sowing unit has been developed for sowing seeds of desert fodder plants (Fig. 1 and Fig. 2), the process of sowing seeds on which to occur as follows.

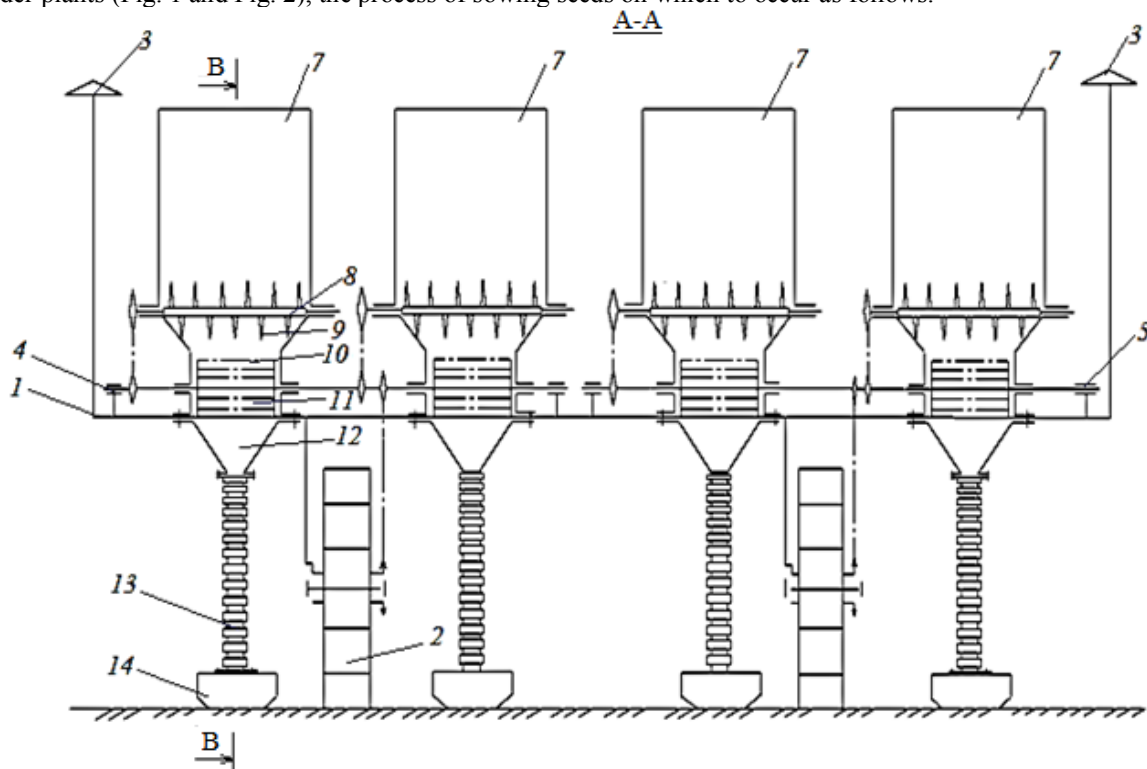

Fig. 2. Diagram of the universal sowing unit, section A-A in Fig.1

Before starting the work of the sowing unit, quadrangular bunkers 7 are filled with seed mixture. The movement of the sowing unit across the field is carried out by the running gear of the tractor 17. When the unit moves across the field, the rotating wheels 2 transmit the drive to the left 4 and right 5 horizontal shafts.

The rotating left 4 and right 5 horizontal shafts, in turn, transmit the rotation of the seed mixture softeners 8, mounted on bearings in the lower bases of the quadrangular bins 7. The left horizontal shaft 4 transmits rotation to the two left shafts 8 of the seed mixture softeners, and the right shaft 5, in turn, transmits, rotation to two right shafts 8 seed mixture softeners. The execution of the rotation of the walls of the sides of the quadrangular bunkers 900 to the seed mixture softeners provides a sharp decrease in the friction force on the walls of the 7 hoppers and ensures a smooth movement of the seed mixture from the upper part of the 7 hoppers to the lower part of the quadrangular hoppers 7, to the surfaces of the cone-shaped fingers 9 of the seed mixture softeners. The seed mix is above the surfaces of the hoop 9, the softeners of the seed mix, as long as they are not set in motion. In this case, the seed mixture is at rest. The cone-shaped fingers do not allow a sharp drop of the seed mixture to the surfaces of the triangular grooves 11 of the normalizing drums 10.

And thus, a dome over them is not formed. According to the technological process, by rotating the softeners of the seed mixture located above the surfaces of the cone-shaped fingers 9, the seed mixture with the softeners of the seed mixture, picking with their vertically located cone-shaped fingers 9, extracts them in small portions from the total mass of the seed mixture.

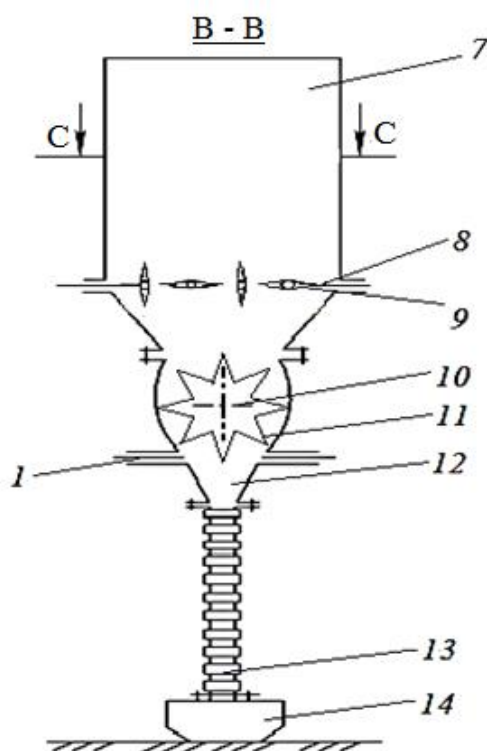

Fig. 3. Diagram of the sowing section of the sowing unit, section B-B in Fig. 2

The selected small portions of the seed mixture correspond to the adjusted norms of the seed mixture, which is ensured by the adjustment of the rotation of the shaft 8 of the seed mixture mixer (Fig. 3). Further, these portions of the seed mixture are uniformly and sequentially fed into the triangular grooves 11 of the normalizing drums 10. In this process, the cone-shaped fingers 9 of the seed mixture mixers, which are in a horizontal state, hold part of the replaceable mixture located above them until these cone-shaped fingers 9, rotating, reach vertical position.

And thus, by rotating the shafts 8 of the seed mixture mixers, their cone-shaped fingers 9 alternately are in a vertical position and then in a horizontal position, while excluding a sharp falling asleep of the seed mixture over the grooves 11, the normalizing drum 10 and the formation of arches, leading to clogging and damage to the seeds. For uniform removal from the surface of the triangular grooved 11 drum 10, and ensuring the seeding rate of the seed mixture, the number of triangular grooves 11 and their rotation speed is selected depending on the size of the seeds.

The selected portion of seeds is fed to the seed guides 12, then the seeds go through the seed tubes 13 to the 14 skid coulters.

Parameters of the universal sowing unit: speed of movement of the sowing machine-tractor unit 1.38-2.22 m/s; working width of the universal sowing unit 3.6 m; the number of the sowing section of the sowing unit is 4 pieces; number of sowing rows 4 rows; bunker volume 0.2 m²; the number of seed mixture mixers in the bunker is 5-6 pieces; lengths of cone-shaped fingers softeners of the seed mixture 6.0-7.0 cm; normalizing drum radius 5.0 cm; number of revolutions of the normalizing drum 26-30 r/min; length of the normalizing drum 7.0 cm; the number of triangular chute is 8 pieces; triangular groove width 3.3 mm; triangular gutter depth 1.6 mm.

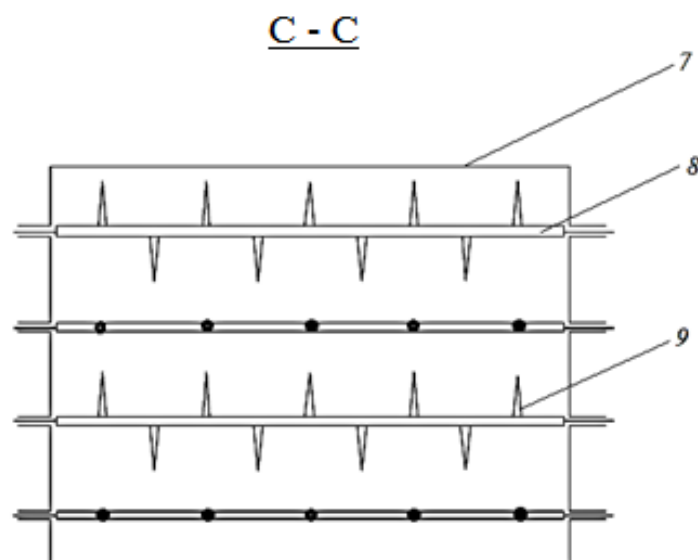

Fig. 4. Scheme softeners of the seed mixture, section in Fig. 3

4. Conclusion

The proposed universal sowing unit ensures the sowing of a seed mixture of desert fodder plants, the physical and mechanical properties of which are very different from a mixture of seeds of other agricultural crops. In the design of the universal sowing unit, a new sowing section with seed mixture softeners has been developed. The sowing section provides the required seeding rate, while the universal sowing unit for sowing seeds of desert fodder plants eliminates crushing, clogging of seeds and preserves their biological germination.

The proposed design of a universal sowing unit for sowing seeds of desert fodder plants has advanced technological capabilities. It provides savings in seed material by eliminating damage to seeds, is simple in design, non-energy-intensive, non-metal-intensive.

In general, the proposed universal sowing unit ensures the sowing of seeds of desert fodder plants in accordance with agrotechnical requirements.

References

1. B. Wróbel, W. Zielewicz, M. Staniak, Challenges of Pasture Feeding Systems—Opportunities and Constraints, *Agriculture* **13**, 974 (2023)
2. D.A. IsaevaO. S. Korotkevich, Characteristics of the Edilbay sheep breed of the Republic of Kazakhstan, Bulletin of NSAU, Novosibirsk State Agrarian University, Novosibirsk (2022)
3. A. Ombayev, H. Ukbaev, A. Abdurasulova, Astrakhan breeds sheep of Kazakhstan, Bulletin of the Academy of Sciences of the Republic of Kazakhstan, Astana (2020)
4. E.Z. ShamsutdinovaZ, Sh. Shamsutdinov, Growth and development of the wild-growing subshrub *Salsola orientalis* SG Gmel in culture under conditions of the Central Asian desert, *IOP Conference Series: Earth and Environmental Science* **901**, 012035 (2021)
5. N. Shamsutdinov, V.Sh. Sanzeev, Z. Shamsutdinov, Ecological restoration of fodder productivity of degraded pastures in the foothill desert zone of Central Asia, *IOP Conference Series: Earth and Environmental Science* **901**(1), 012033 (2021)

6. G.K. Bulakhtina, A.V. Kudryashov, N.I. Kudryashova, A.F. Tumanyan, A.A. Terekhin, Investigation of the influence of various wheatgrass sowing methods on the productivity of improved pastures in the arid zone of the northern Caspian Vestnik of the Mari State University. Chapter "Agriculture. Economics" (2019).
7. Z. Shamsutdinov, Ecological restoration of biodiversity and forage productivity of degraded pasture ecosystems in the Central Asian Desert, *BIO Web of Conferences* **43**, 01025 (2022)
8. M.V. Vlasenko, L.P. Rybashlykova, S.Yu. Turko, Restoration of Degraded Lands in the Arid Zone of the European Part of Russia by the Method of Phytomelioration, *Agriculture* **12**, 437 (2022)
9. N. Shamsutdinov, M. Shagaipov, V. Sanzheev, Ecological restoration of degraded pasture lands in the Circum-Caspian Sea semi-desert, *E3S Web of Conferences* **222**, 02023 (2020)
10. Z.S. Shamsutdinov, V.M. Kosolapov, N.Z. Shamsutdinov, About the concept of ecological niche and its role in design of adaptive arid pasture agroecosystems. *Agricultural Biology* **78**, 456 (2018).
11. N. Namozov, M. Saidova, M. Urmanova, Effective methods of preventing degradation of desert pasture soils of Uzbekistan, *IOP Conference Series: Earth and Environmental Science* **1068**(1), 012035 (2022)
12. B Mukhambetov et al., Soil cultivation efficiency in pasture management of the arid zone of Central Asia and Kazakhstan, *IOP Conf. Ser.: Earth Environ. Sci.* 839 022029 (2021)
13. V.G. Grebennikov, I.A. Shipilov, L.R. Ashibokova, Ways to improve low-yield hayfields and pastures in arid areas, *Agrarian science*, Moscow (2021)
14. O. Marchenko, A. Tekushev, Prospective technologies, types and calculation of the technical means for the production of forages in Arid Regions of the Country. AMA, *Agricultural Mechanization in Asia, Africa and Latin America* (2019)
15. C. Zucca et al., Land restoration by fodder shrubs in a semi-arid agro-pastoral area of Morocco. Effects on soils, *CATENA* **87**, 306-312 (2011)
16. N.P. Kryuchin, Mechanization of seeding of the phytomeliorant plants, *Inovatika and Expertise* **20**, 205-209 (2017)
17. B.A. Eviev, B.I. Belyeva, N.G. Ochirov, Technologies and technical means for sowing non-flowing seeds offorage grasses, All-Russian scientific and practical conference on fundamentals of scientific, technical and technological modernization of the agro-industrial complex (FONT and TM-APK-13) materials, Russia (2013)
18. E.D. Turxachev, V.Kh. Maliev, Substantiation of the operating mode and design parameters of the seeding part of the seeder for sowing non-loose seeds of forage plants, *Bulletin of the Agro-industrial Complex of Stavrapolye* **10**, 127-131 (2013)
19. M.D. Aduov, S.A. Nukusheva, E.J. Kaspakov, Substantiation of the design parameters of machines for sowing non-dry grass seeds, *Mechanization in Agriculture and Economy of Resources* **2**, 50-52 (2019)
20. F.V. Posharikov, V. Popov, Results of research of a new seeding apparatus of a forest seeder, *Modern Problems of Science and Education* **1**, 159 (2012)
21. E.T. Farmonov, A.I. Korsun, I.G. Gorlova, Patent RUz № 04515, Wide-grip seeder, *Byull* (2009)
22. E.T. Farmonov, A.N. Sadirov, F.E. Farmonova, Patent RUz № 06604, Combined modular planter for desert fodder plants, *Byull* (2021)
23. E. Farmonov, Z. Ismailova, T. Abdilaev, F. Farmonova, Mechanized sowing of seeds of desert fodder plants, *IOP Conference Series: Materials Science and Engineering* **883**, 012096 (2020)