

PAPER • OPEN ACCESS

## Formation and justification of the parameters of the comb for laying the drip irrigation hose and sowing seeds

To cite this article: B P Shaymardanov *et al* 2023 *IOP Conf. Ser.: Earth Environ. Sci.* **1284** 012040

View the [article online](#) for updates and enhancements.

**PRIME**  
PACIFIC RIM MEETING  
ON ELECTROCHEMICAL  
AND SOLID STATE SCIENCE

HONOLULU, HI  
Oct 6–11, 2024

Abstract submission deadline:  
**April 12, 2024**

Learn more and submit!

**Joint Meeting of**

The Electrochemical Society  
•  
The Electrochemical Society of Japan  
•  
Korea Electrochemical Society

# Formation and justification of the parameters of the comb for laying the drip irrigation hose and sowing seeds

**B P Shaymardanov<sup>1\*</sup>, P T Berdimuratov<sup>1</sup>, D M Ruziev<sup>1</sup> and A G Rakhimov<sup>2</sup>**

<sup>1</sup>"Tashkent Institute of Irrigation and Agricultural Mechanization Engineers" National Research University, 39, Kari-Niyaziy, Tashkent 100000, Republic of Uzbekistan

<sup>2</sup>PC "GSKB-Agromash", 210, Mashxadiy, Tashkent 100000, Republic of Uzbekistan

\*E-mail: shaymardanovvb@mail.ru

**Abstract.** The article presents the results of a study on the formation and justification of the parameters of a comb for laying a drip irrigation hose and sowing seeds. The features of the agrometeorological conditions of Uzbekistan during spring sowing are studied. Based on the variability of weather - precipitation, atmospheric air temperature and soil, the parameters of the ridge size are justified. The design of the machine for pre-sowing strip milling of the soil, the formation of the ridge, the laying of the drip irrigation hose, soil compaction, providing physical and mechanical soil of the ridge and the possibility of sowing seeds, is proposed. The design of a milling machine for strip processing with the formation of a ridge of a given shape, composition and parameters, a ridge sealer according to the required soil density has been developed. The main parameters of the comb shaper are substantiated.

## 1. Introduction

To study the features of agrometeorological conditions of Uzbekistan during spring sowing materials of the Uzhydrometeorological Center were collected from March 25 to April 25 on air temperature, soil and precipitation in the Tashkent and Andijan regions [1].

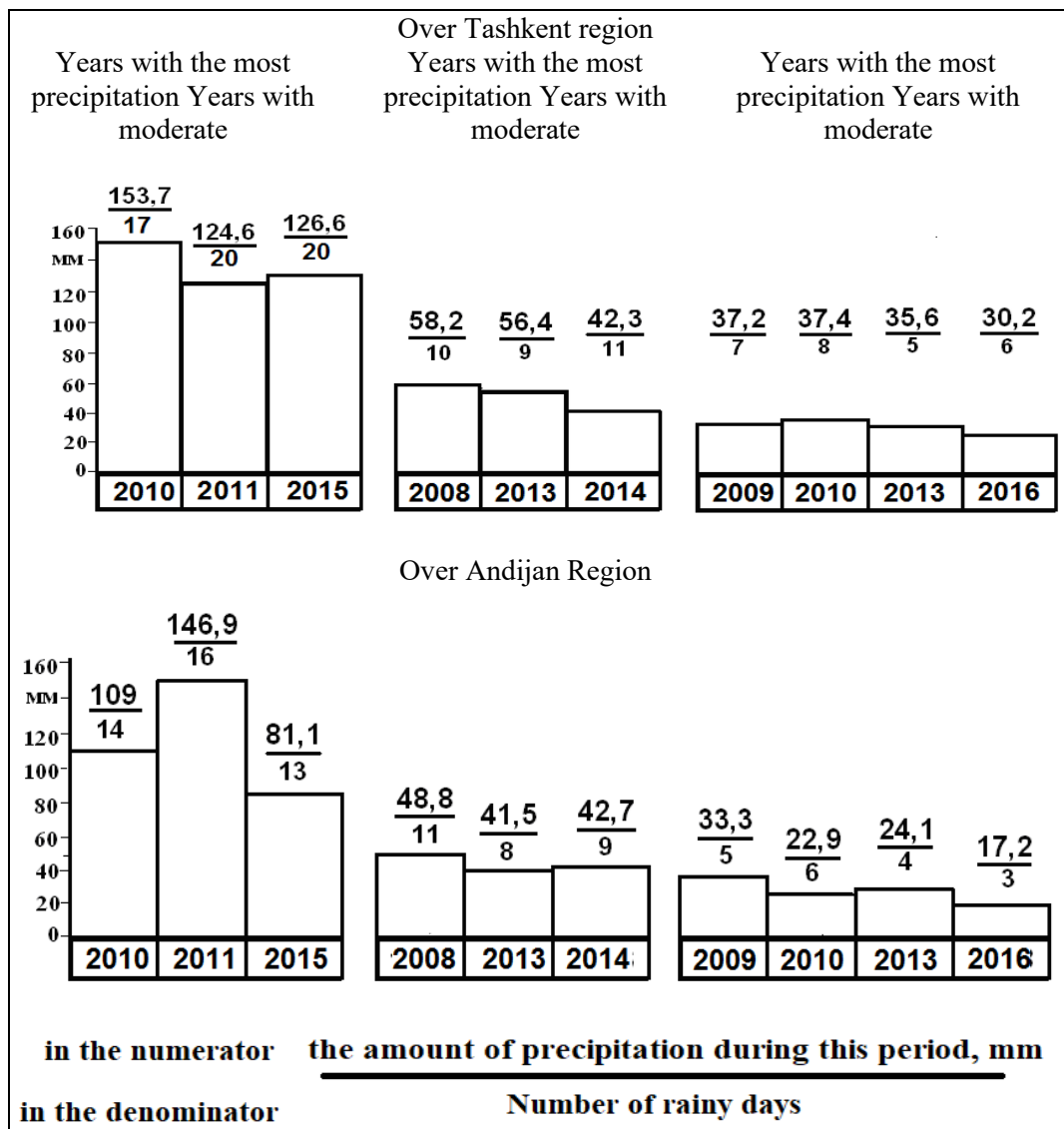
A very important factor here is the amount of precipitation and their intensity during the sowing period, since the appearance of a soil crust over the seedbed, the source of re-sowing, depends on it.

The greatest amount of precipitation from 91.1 to 153.7 mm and its intensity from 13 to 21 days occurred in the period 2010-2012. It is known that as a result of high intensity and a large amount of precipitation, the seedbed is flooded by rain streams, which contributes to the formation of a soil crust and, accordingly, the deterioration of the development of seedlings. The results of this analysis are shown in Figure 1. Figure 2 shows that due to the formation of a soil crust 4 on the field 2 above the seedbed 3, after precipitation, the seeds die.

In recent years, the Republic of Uzbekistan has started using crops on ridges cut in autumn to protect crops from rain flows, exclude replanting, and, accordingly, increase crop yields. However, to carry out sowing using this technology, it is necessary to cut the ridges in the fall on the field, and before sowing, prepare the top of the ridge for this operation, which requires at least two separate units, which increases operational and labor costs by 3-3.5 times. In addition, during this period there were years with a small amount of precipitation (2000, 2001, 2004, 2008) (from 17.2 to 37.4 mm) and their intensity (from 4 to 8 days). This amount of precipitation is insufficient for the normal development of seedlings. To

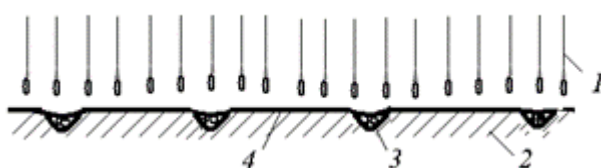


eliminate this phenomenon, it is necessary to carry out feeding irrigation with a small amount using drip irrigation.

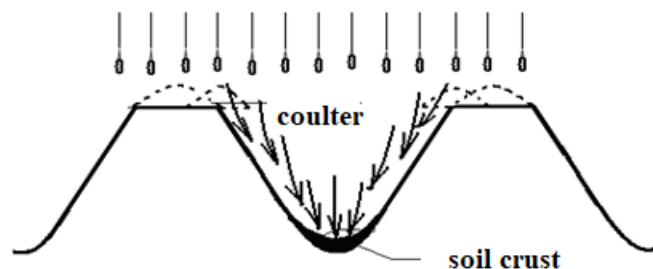


**Figure 1.** Precipitation and its intensity during the cotton sowing period for 10 years (from March 25 to April 25) according to the data of Uzhydromet.

It follows from this that in order to eliminate excess moisture or its insufficiency, it is best to sow cotton on ridges formed simultaneously by laying a drip irrigation hose, which will allow for less cost and in a short time to eliminate the effects of precipitation on seedlings and protect them from rain flows and, if necessary, carry out feeding irrigation [2-4].



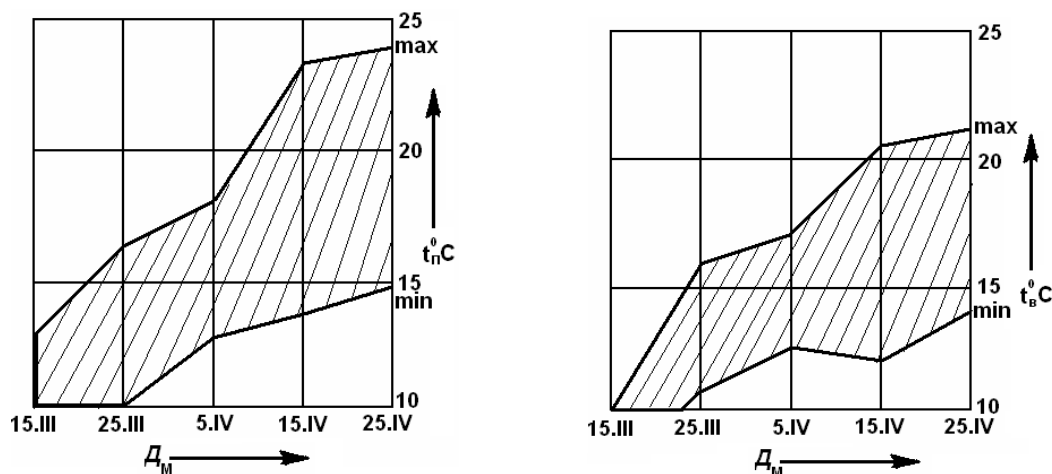
**Figure 2.** Sowing on a smooth floor (traditional method of sowing)



**Figure 3.** Scheme of formation of soil crust on the sides of the ridges when sowing cotton on the removed ridges

The second important factor for the emergence of seedlings is the temperature of the soil and air. So at a soil temperature of 10-120C, the awakening of the vital activity of cotton seeds begins, at 13-140C the embryo begins to grow, at 14-160C seed germination begins, and at 17-180C the emergence of seedlings on the soil surface is ensured. At the same time, the difference between daytime and nighttime temperatures ranges from 9 to 160C, at night the temperature difference between adjacent calendar days is only 2-40C. While in the daytime it ranges from 3 to 60C [5-8].

According to the data, it can be seen that at night in a favorable for cotton growing in 2005, the minimum air temperature at night was from 7 to 140C, and in the same period in an unfavorable 2003 it ranged from 1 to 90C, that is, below 2005 by 5-60C, and during daytime in 2005 it fluctuated from 15 to 190C, that is, above the temperature of 2003 by 3-60C, (Fig.4).



**Figure 4.** Average daily air temperature ( $t_b$ ) and soil surface ( $t_n$ ) from March 15 to April 25 (DM) for the last 10 years

It follows from this that an increase in air temperature and, accordingly, soil temperature allows sowing at an early date, which contributes to the production of healthy plant seedlings. The results of experimental studies show that with comb sowing on the soil layers of the root system of plants, the temperature increases. This is explained by the difference in the heat capacity of different bodies, for example, the heat capacity of air is 1.0, and for water it is 4.19. Hence, if we take into account that the driving force is considered to be the heat of the body, determined by the equation:

$$Q = Mct, \text{ kJ},$$

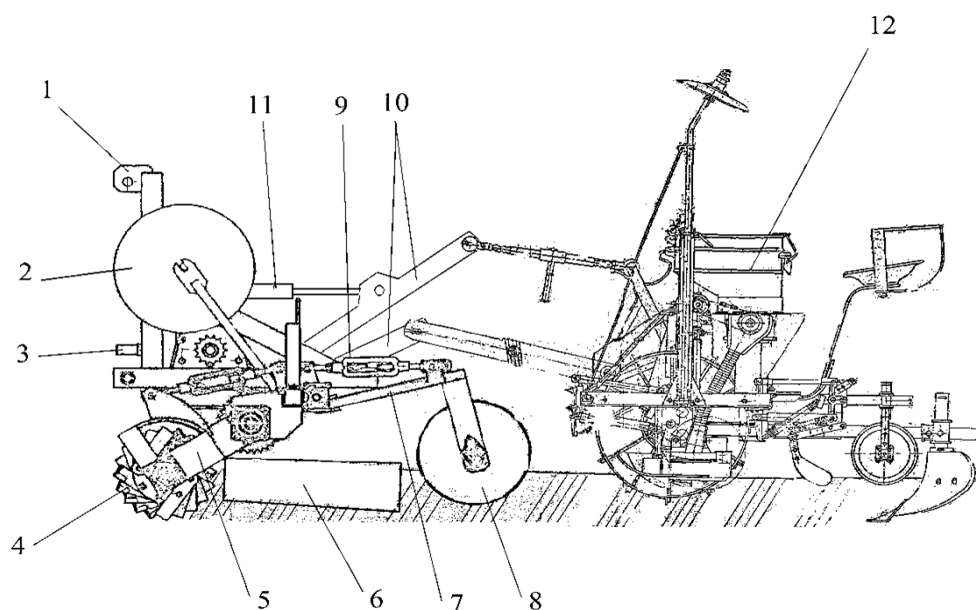
where  $Q$ – the amount of heat to the root system, KJ ;  $c$  – body heat capacity, kJ/kg gr; for air  $c_v$  =1 kJ/kg \*gr; for water  $c_v$  = 4,19 kJ/kg gr;  $t$  – soil temperature, °C.

To eliminate the harmful effects of risky weather conditions on cotton crops, first of all, it is necessary to eliminate the ingress of rain flow into the seedbed. With this technology, cotton seeds will be embedded in a wetter and warmed soil than when sown on a leveled surface. This makes it possible to improve the quality of seedlings and plant development and thereby increase the total crop yield and shift the sowing time by 3-4 days.

## 2. Materials and methods

The purpose of this study is the development of a milling machine for strip processing with the formation of a ridge of a given shape, soil composition and parameters, a ridge sealer for a given soil density.

A combined machine has been developed for pre-sowing strip milling of the soil with simultaneous laying of drip irrigation hoses and the possibility of sowing seeds (Figure 5). The machine consists of two parts: a comb cutter and a seeder.



**Figure 5.** Combined machine for pre-sowing strip milling with simultaneous laying of drip irrigation hoses and the possibility of sowing: 1- milling cutter frame; 2-babina for drip irrigation hoses; 3- milling cutter drive gear shaft; 4-cutter knife drum; 5-knife drum bracket; 6-comb-forming apron; 7-comb bracket-a sealing roller; 8-a comb-sealing roller; 9-a turnbuckle for adjusting the sealing roller; 10-a mounted device for a seeder; 11-a hydraulic cylinder of a mounted device for a seeder; 12-a seeder.

The machine works as follows. In the period of preparation for sowing seeds, instead of harrowing and milling, the soil is milled with the simultaneous formation of a ridge of a given shape and the laying of drip irrigation hoses. Then the soil is compacted to the required density.

When milling, the crusts of the soil are deformed and its wet and dry components are mixed, thereby ensuring the uniformity of the mechanical composition and humidity [9-12]. In years of insufficient moisture in the soil, immediately after sowing, absorbent irrigation is carried out using drip irrigation.

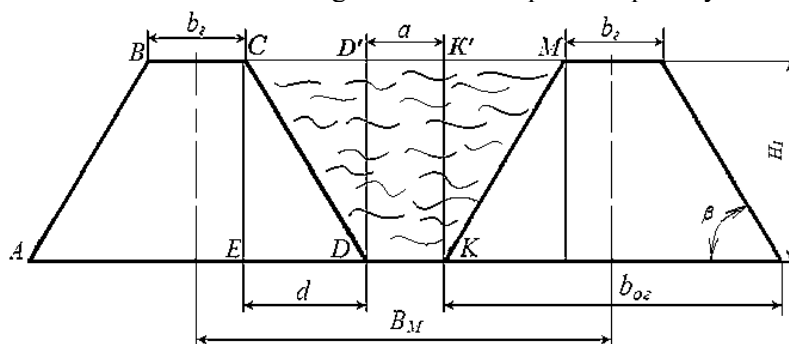
## 3. Results and discussion

In many regions of Uzbekistan, one of the main requirements for the parameters of the ridge is the ability to protect the seedbed from flooding by rain flows and, consequently, to protect it from crust formation. During the operation of the cutter, ridges are formed, the walls of which crumble at an angle of natural slope. At the same time, the angle of natural slope of gray-earth soils prepared for sowing when it is filled with an increase in soil moisture from 7 to 18% increases from 32 to 41°. Consequently, when the

soil is poured into the field, ridges are formed in the form of an isosceles triangle. However, for the working bodies of seeders to work on top of such a ridge, it is necessary to have a platform with a width of 160-170 mm. To do this, the top of the ridge is sealed with a trapezoid shape seal along the longitudinal section, therefore, after that, such a ridge turns into an isosceles trapezoid before sowing (Figure 6). This form, which we take as the basis for subsequent calculations.

To determine the minimum permissible parameters of the ridge formed during sowing, we proceed from the fact that they are not flooded by rain streams. Such ridge parameters will be acceptable for gray-earth soils in the old irrigation zone of our republic, where the fields have a sufficient slope and a fertile soil layer [13-15].

The main parameters of the ridge include the width of the lower base  $b_g$ , the width of the vertex  $b_g$ , the angle of inclination of its wall to the horizon and the height of the ridge  $H$ . Figures 2 and 3 show that to ensure the protection of the seedbed, the cross-sectional area of the row spacing groove SSDKM should be greater than the cross-sectional area of precipitation in the row spacing per day ( $Q_s V_m$ ). According to the data of the Uzbek Hydrometeorological Center for the last ten years in April, up to 34 mm of precipitation fell in the Tashkent region as much as possible per day.



**Figure 6.** Scheme for determining the parameters of the ridge

To determine the parameters of the ridge, we assume that the precipitation should be placed in the groove of the row spacing, i.e. in the space between adjacent ridges. From here

$$B_m Q_s = S_{CDKD}. \quad (1)$$

From Fig.6 we have

$$S_{CDKM} = S_{CDD'} + S_{D'K'KD} + S_{K'MK'}, \quad (2)$$

where  $S_{CDD'}$ ,  $S_{D'K'KD}$  and  $S_{K'MK'}$  - accordingly, the area of the triangles  $CDD'$ ,  $K'MK'$  and a rectangle  $D'K'KD$ .

From Figures 2 and 3 we have the following equations:

$$S_{CDD'} = S_{K'MK'} = \frac{1}{2} d H_1 = \frac{H_1^2}{2} ctg\beta, \quad (3)$$

$$S_{D'K'KD} = a H_1, \quad (4)$$

where  $H_1$  is the minimum allowable height of the ridge;  $\beta$  is the angle of the natural slope of the soil;  $a$  is the width of the bottom of the groove.

The width of the bottom of the groove  $a$  is equal to

$$a = B_M - b_g - 2H_1 ctg\beta, \quad (5)$$

where  $b_g$  is the width of the crest vertex.

Substituting the value of  $a$  in (4) we have:

$$S_{D'K'KD} = (B_M - b_g - 2H_1 ctg\beta) H_1 \quad (6)$$

Substituting the values (3) and (6) first into (2), and then the resulting result into formula (1) we will have:

$$B_m Q_c = H_1 (B_M - b_g) - H_1^2 ctg\beta. \quad (7)$$

Having made the transformation of this formula, we obtain the following equation:

$$H^2 - (B_M - b_g)H_1 t g \beta + B_M Q_c t g \beta = 0. \quad (8)$$

Having solved equation (8), we obtain the following dependence for determining the minimum allowable height of the ridge:

$$H_1 = 0,5 \left[ (B_M - b_g) t g \beta - \sqrt{[(B_M - b_g) t g \beta]^2 - 4 Q_c B_M t g \beta} \right] \quad (9)$$

When cutting the ridge, its side walls crumble at the angle of the natural slope  $\beta$ . At the same time, the soil moisture prepared for cutting the ridge usually ranges from 12 to 14%, and depending on this, the angle of the natural slope  $\beta$  varies from 32 to 41°. Based on this, the minimum calculated height of the ridge  $H$ , as can be seen from the formula (9), practically very little depends on the magnitude of the angle of the natural slope  $\beta$ , as well as on the size of the top of the ridge  $b_g$  and is mainly determined by the amount of precipitation that fell during the day  $Q_c$ .

Taking  $Q_c = 34$  mm,  $b_g = 160$  mm,  $h = 36$  mm and  $\beta = 36^\circ$  and using formulas (9) we get that at  $B_m = 900$  mm the height of the ridge  $H_1 = 45.1$  mm, and at  $B_m = 600$  mm the height of the ridge  $H_1 = 56.2$  mm.

As is known, under the influence of precipitation, the ridge settles. At the same time, as studies have shown, the coefficient that takes into account the shrinkage of the soil, depending on the height of the ridge, is  $C_u = 0.85-0.90$ . The actual minimum allowable height of the ridge also depends on the height of the irregularities of the surface of the field  $h$ , which is on average 30-40 mm. With this in mind, the actual minimum height of the ridge  $H_1$  in order to protect its top from the rain flow should be equal to:

$$H_1 = \frac{1}{2K_y} [(B_M - b_g) t g \beta - \sqrt{[(B_M - b_g) t g \beta]^2 - 4 Q_c B_M t g \beta}] + h, \quad (10)$$

Taking into account this formula and the above data,

$$\text{by } B_M=900 \text{ mm } H_1 = \frac{45,1}{0,9} + 36 = 86,1 \text{ mm}; \quad \text{if } B_M=600 \text{ mm } H_1 = \frac{56,3}{0,9} + 36 = 98,6 \text{ mm}.$$

From these data it follows that rainwater does not flood the top of the ridge, its height should be practically at least 100 mm. In this case, the width of the lower base of the ridge will be

$$b_{og} = 2H_1 c t g \beta + b_g. \quad (11)$$

The cross-sectional area of such a groove

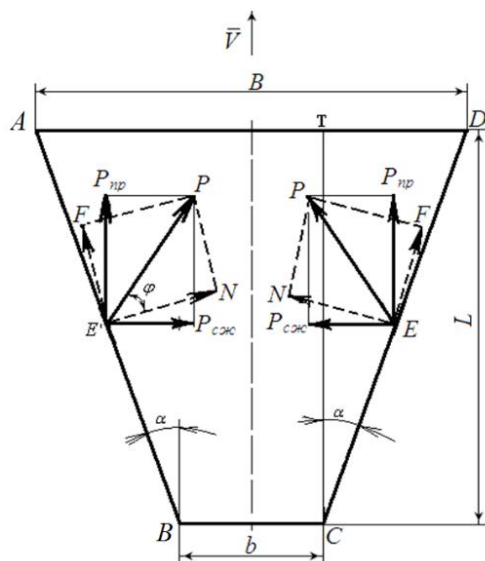
$$S_g = (B_M - b_{og})H_1 + H_1^2 c t g \beta. \quad (12)$$

Substitute the above values into these expressions and the values  $H_1$ ,  $\beta$ ,  $b_g$ ,  $B_m$  are obtained, we get  $b_{og} = 435,28$  mm и  $S_g = 306$  sm<sup>2</sup> if  $B_m = 900$  mm and 204 cm<sup>2</sup> if  $B_m = 600$  mm.

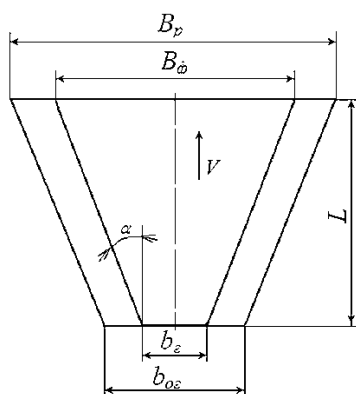
Thus, the calculations show that in order to eliminate the ingress of rain flow into the seedbed, it is necessary: the minimum allowable height of the ridge  $H_1$  should be at least 100 mm; minimum allowable width of the crest vertex  $b_g$  from the point of view of stable operation of seeding devices should be at least 160 mm; permissible width of the lower base of the ridge  $b_{og}$  must be at least 435 mm; permissible cross-sectional area of the groove  $S_g$  must be at least 306 sm<sup>2</sup> by  $B_m = 900$  mm and 204 sm<sup>2</sup> by  $B_m = 600$  mm.

The main parameters of the shaper are the width of the input and output edges of the shaper's slide, the angle of installation of the side dumps to the direction of movement  $\alpha$  and to the horizontal plane  $\beta_y$ , length of the slide  $L$ , side blade length  $L_{bo}$ .

During operation, the side dumps of the mold impact on the soil produce soil deformation (Fig. 7). At the same time, soil particles move laterally upwards.



**Figure 7.** Scheme for determining the angle of installation of side dumps to the direction of movement.



**Figure 8.** Scheme for determining the length of the shaper ( $L$ ).

Angle of inclination of the side face of the ridge ( $\beta_y$ ) (fig.8) depends on its compaction. If the angle of the natural slope of the soil on the side face, depending on humidity, varies from  $32^\circ$  to  $41^\circ$ , and with its sealing, the angle  $\beta_y$  can be increased to  $42^\circ$ - $45^\circ$  [16].

Substituting in (12) a known value  $\varphi=30^\circ$ , we get  $\alpha \leq 30^\circ$ . Based on research on the choice of seal parameters, we accept  $\alpha=14$ - $16^\circ$ . By  $\alpha=14$ - $16^\circ$  the soil slides along the side blade of the shaper and compacts the soil sufficiently to form a stable ridge.

From Figure 7 we have:

$$L = \frac{1}{2}(B_p - b_{og})ctg\alpha \tag{13}$$

and

$$B = 2Ltg\alpha + b_g. \tag{14}$$

Substituting in (13) and (14) the values  $B_p$ ,  $b_{og}$  and  $\alpha$  we get, that the length of the shaper should be within  $L = 183$ – $238,9$  mm, and the width of the shaper's entrance apron  $B=292$ - $334$  mm.

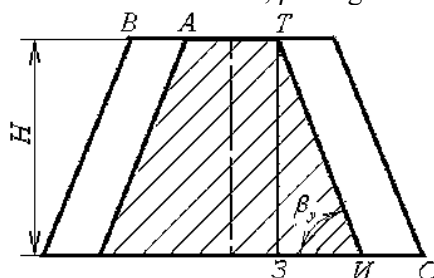
As a result of studying the method of forming a platform for the work of the working bodies of sowing machines, it was revealed that it was necessary to seal the side face of the ridge to eliminate its



shedding [17]. To do this, it was necessary to fulfill the following condition, so that the angle of the slope  $\beta_y$  to the plane of the field was no more than

$$\beta_y \leq \beta + \phi, \quad (15)$$

where  $\phi$  – the angle of internal friction of the soil;  $\beta$  – angle of natural slope of the soil.



**Figure 9.** Scheme to substantiate the angle of installation of side dumps to the horizon.

Based on this, in order to eliminate the shedding of the side faces of the ridge, it is necessary to place the side dumps of the shaper at an angle  $\beta_y = 42 - 45^\circ$  to the horizontal plane of the field.

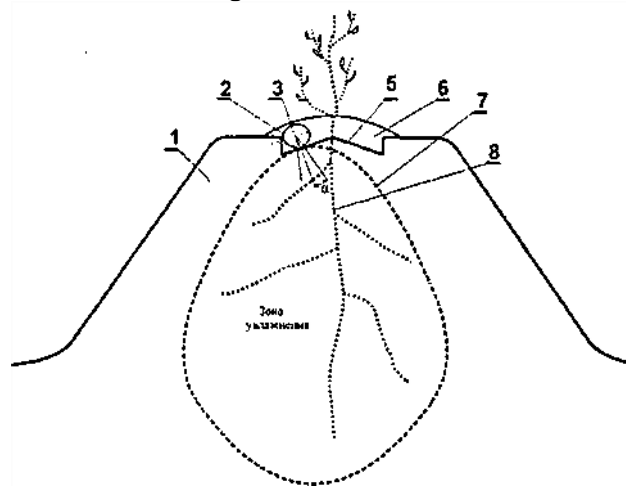
When working, the visor of the shaper's apron affects the soil and causes soil deformation. Installation angle  $\alpha_1$  the apron visor will be determined from the condition of ensuring the sliding of the soil on it, i.e.

$$\alpha_1 \leq \frac{\pi}{4} - \frac{\phi}{2}, \quad (16)$$

Substituting a known value into this expression  $\phi = 25-30^\circ$  we get  $\alpha_1 = 30-34^\circ$ .

The height of the blade  $h$  is assumed to be equal to the minimum allowable height of the ridge  $H_1$ , i.e.  $h = 100$  mm.

With these parameters of the shaper's side dumps, a ridge with a height of at least 100 mm and a density of is formed on the field 1,0-1,2 g/cm<sup>3</sup>.



**Figure 10.** The scheme of laying the irrigation hose on the ridge.

The irrigation hose is laid on the ridge by water outlets above the soil surface and covered with a layer of soil, the angle of deviation from the axis of the water outlet to the soil surface should not exceed  $15^\circ$ . The location of the irrigation hose is shown in Figure 10, where the cross section of the bed 1, irrigation hose 2, water outlet 3, trace 5 from the sealing roller of the seeder, soil layer 6 to cover the hose from solar radiation, contour 7 of the humidification zone, root system 8 of the plant, angle  $\alpha$  of the deviation of the axis of the water outlet to the soil surface is schematically presented [18-19].

The irrigation hose is laid out in the field along the rows of plants on the ridge along the trail of the sealing pipe installed behind the comb shaper.

#### 4. Conclusion

Based on the analysis of the weather conditions during the preparation and sowing of seeds, it was established that the minimum allowable height of the ridge  $H_1$  must be at least 100 mm; minimum allowable width of the crest vertex  $b_g$  from the point of view of stable operation of seeding devices should be at least 160 mm; permissible width of the lower base of the ridge  $b_{og}$  must be at least 435 mm.

Based on the analytical analysis, the parameters of the shaper are determined: the length of the shaper should be within  $L = 183\text{--}238,9$  mm, and the width of the shaper's entrance apron  $B=292\text{--}334$  mm, angle of installation of side dumps  $\beta_y = 42 - 45^0$ , height of the blade  $h$  equal to the minimum allowable height of the ridge  $H_1$ , i.e.  $h = 100$  mm. The density of the soil in the ridge is  $1,0\text{--}1,2$  g/cm<sup>3</sup>. 3) With this method of drip irrigation, the heat content of the soil in the root system zone will be almost constant during the time of the day.

#### References

- [1] Materials of the Uzhydromet on the daily amount of precipitation from March 25 to April 25 from 2008-2017 No. 25-01/532 of 09/15/2017
- [2] Mamatov F, Mirzaev B, Berdimuratov P, et al. 2021 *IOP Conf. Series: Earth and Environmental Science* **868** 012052
- [3] Berdimuratov P T 2019 *Development and justification of the parameters of the comb shaper for a cotton seeder* (Tashkent)
- [4] Akhmetov A 2017 *The tendency to improve the design of cotton-growing pre-sowing tillage machines-tools* (Tashkent)
- [5] Shaimardanov B P, Matchanov R 2017 *Irrigation hose for drip irrigation and the method of its installation* Patent UZ IAP 06314 14 10 2020 (21) IAP 2017 0013 № (22) 12 01 (Tashkent)
- [6] Shaimardanov B P, Isakov A and Mirnigmatov B 2020 *IOP Conf. Series: Materials Science and Engineering* **883** 012153
- [7] Kurdyumov V et al. 2012 Bulletin of Saratov State Agrarian University named after Vavilov **11** 55-60
- [8] Shaimardanov B. P. 2022 *IOP Conf. Series: Earth and Environmental Science* **1076** 012064
- [9] Kurdyumov V et al. 2017 *Technology and means of mechanization of ridge cultivation of row crops* (Ulyanovsk: Vega MC)
- [10] Chernoiivanov V I, Ezhevsky A A, Fedorenko V F 2014 *Intelligent agricultural machinery* (M. FSINI "Rosinformagroteh")
- [11] Rudakov G M 1974 *Technological fundamentals of mechanization of cotton sowing* (Publishing house "Fan" Tashkent)
- [12] Abdumutalov A Yu 1954 *The study of the closing and rolling working bodies of cotton seeders* (Tashkent)
- [13] Sablikov M V 1950 *Agrecultural machines* (Tashkent State Publishing House of the Uzbek SSR)
- [14] Kostyakov A N 1960 *Fundamentals of Land Reclamation* (M. Selkhozgiz)
- [15] Sergienko V A 1959 *The study of the working bodies of the cotton cultivator* (Tashkent)
- [16] Kondratyuk V P, Pogosov Yu A 1979 *Recommendations for sowing cotton on ridges and ridges* (M. Ministry of Agriculture of the USSR)
- [17] Pogosov Yu A, Sharipov N Sh, Kunduzov A M 1982 *Recommendations for cultivating cotton on ridges* (M. TSNIITI)
- [18] Mukhamedzhanov M, Sulejmanov S 1978 *The root system and productivity of cotton* (Uzbekistan Publishing House, Tashkent)
- [19] Kalinin A B, Ruzhiev V A, Teplinsky I Z, *World trends and modern technical systems for potato cultivation* (SPb: Prospect of Science)