

PAPER • OPEN ACCESS

Optimum factors of a renewable energy plant from poultry organic waste

To cite this article: Sh Imomov *et al* 2023 *IOP Conf. Ser.: Earth Environ. Sci.* **1231** 012026

View the [article online](#) for updates and enhancements.

You may also like

- [MoS₂-Based MOS Capacitor for In-Memory Light Sensing](#)
Dayanand Kumar, Ayman Rezk, Ammar Nayfeh et al.
- [A desalination plant with solar and wind energy](#)
H Chen, Z Ye and W Gao
- [Failures statistics of on-line monitoring devices for gases dissolved in oil](#)
Shuang Liu, Wenhao Wang, Rui Han et al.



245th ECS Meeting • May 26-30, 2024 • San Francisco, CA

[Learn more & submit!](#)

Present your work at the leading electrochemistry & solid-state science conference.

Network with academic, government, and industry influencers!

Submit abstracts by December 1, 2023



Optimum factors of a renewable energy plant from poultry organic waste

Sh Imomov^{1*}, K Usmonov² I Nuritov² and V Tagayev³

¹Bukhara Institute of Natural Resources Management, Republic of Uzbekistan

²"Tashkent Institute of irrigation and agriculture mechanization engineers" National research university, Republic of Uzbekistan

³National University of Uzbekistan named after Mirzo Ulugbek, Republic of Uzbekistan

*E-mail: usmonov-74@inbox.ru

Abstract. The article presents the parameters of the device for renewable energy from poultry organic waste. The authors describe the experimental device for the anaerobic processing of poultry organic waste and the results of the implementation of the device. Broad considerations about obtaining alternative energy sources if the dilution mode is used for the first time in the device for obtaining biogas from poultry organic waste are given. Anaerobic treatment of poultry organic waste in a bioreactor was used to absorb odorous gases and to analyze the production of biogas at different temperature regimes by the method of dilution.

1. Introduction

In recent years, in our country, the use of non-traditional energy sources has been widely implemented in the areas of development of the energy sector. In particular, gas and fertilizer, which can be obtained through certain types of processing of animal and plant waste, are currently included in the list of renewable energy source waste [1]. In addition, it is possible to use algae and halophyte processing technologies intended for the treatment of polluted water coming out of large industrial enterprises in the republic.

There are two main types of waste treatment: aerobic (in an oxygen environment) and anaerobic (in an oxygen-free environment). It is known that the anaerobic method of waste treatment does not require a lot of energy. The microbiological requirement for this process is such that even a small change in it can stop the process. The intensive consumption of organic resources leads to the increase of greenhouse gases, and the problem of greenhouse gases released as a result of open burning of wastes encourages world scientists to look for new ways of using renewable energy sources.

2. Materials and methods

Nowadays (last 20 years) anthropogenic climate change is causing global problems. Local heat waves, high winds and floods are the result of increased greenhouse gases in our atmosphere. And these are anomalous changes taking place not only within the borders of one country, but throughout the world. In order to reduce such unpleasantness, the main focus of conventions, seminars and roundtable discussions, agreements and debates held within the framework of the UN is focused on the drastic reduction of organic waste emitted from the processing of outdoor air [2].



For this purpose, an experiment-production device for anaerobic processing of poultry organic waste was assembled (figure 1)

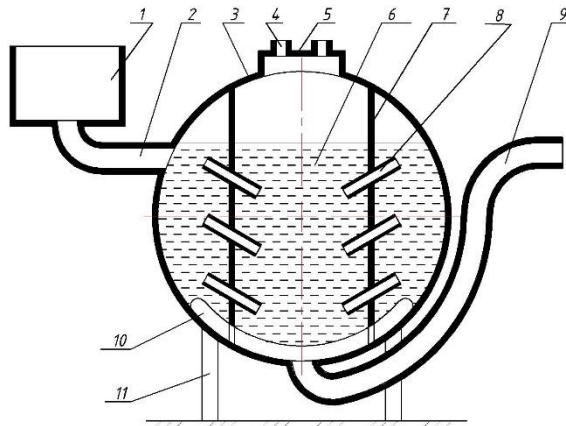

Figure 1. Principle scheme of the biogas plant. 1-daily biomass load dispenser; 2-biomass tank pipeline; 3-bioreactor; 4-thermostat; 5-rarefaction control device; 6-biomass; 7-obstacle; 8-mixer pipes; 9-drain pipe; 10-biomass heating device; 11-support columns.

The optimal process factors of the device for obtaining renewable energy from organic poultry waste are a complex of actions that take place in the anaerobic process, such as: climatic conditions during the collection of biomass, anaerobic treatment at the place of its collection, the time of storing clean biomass in bioreactors until it creates an anaerobic environment, the antibiotic content of biomass. pH environment, the amount of biomass fed into the bioreactors per unit of time, the duration of anaerobic treatment, the temperature regime (mode) in the bioreactor, the biogas pressure during treatment, etc. Methane gas involved in the anaerobic treatment of organic waste and approximately one-third of the released biogas is produced by bacteria that develop in a complex process [3].

Sudden changes in climate conditions make it difficult to maintain a stable temperature regime in biogas plants, and in large biogas production plants, the results of our many experiments have shown that if the daily temperature changes in a short period of time are not very large, the gas output amount (graph) is not significantly affected. [4].

During the operation of the proposed biogas plant operating in the dilution mode during the anaerobic processing of poultry organic waste, the results obtained in the thermophilic, mesophilic and psychrophilic temperature regimes of the biogas plant at all optimal technological parameter values are presented in figure 2.

As can be seen from figure 2, it can be seen that biogas plants start to pre-treat poultry organic waste in the process of anaerobic treatment, and it can be seen that the absorption of volatile odorous gases and organic ammonium and the reduction of the negative impact of free gas bubbles on the process can be seen [5].

Although the state of anaerobic process at temperatures has been observed by many scientists for many years, its exact limit parameters have not been determined until now. It can be seen from the results of our further experiments that the definition of different boundary conditions (in the range of 20...60 0C) is a relative indicator, and that the main parameter here depends on the temperature moderation of the installed place of biogas plants in climate change [6].

We have information about the preparation and implementation of various thermal protection materials in different forms in order to moderate the heat temperature conditions in renewable energy production devices of biogas obtained from poultry organic waste [7]. In addition, in the analysis of the literature and according to the results of scientific research, it was found that a small amount of total energy (up to 7%) is spent in the preparation and absorption of biomass for the fermentation process and the use of insulation against heat loss to the environment through the surface of the bioreactor and its equipment, but most external unprotected devices have these costs up to 100%.

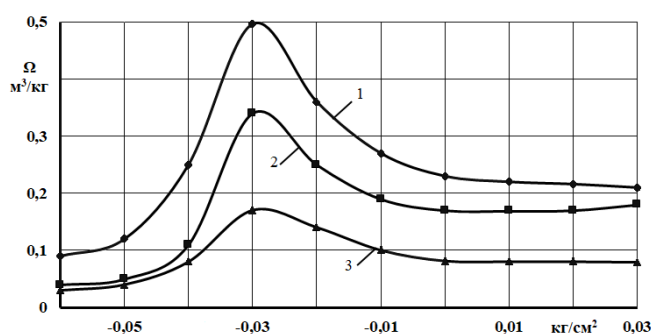

Figure 2. Obtain biogas in any thermophilic (curve 1), mesophilic (curve 2) and psychrophilic (curve 3) modes of food-producing biogas construction in dilution mode.

3. Results and discussion

It is necessary to ensure the moderation of its constituents in the anaerobic treatment in the climatic conditions of Uzbekistan for the one-component state of poultry organic waste, the initial treatment and the bottom of the first holding device.

As can be seen from the above, poultry organic waste is the product of a very large concentrated feed unit, which leads to great complications for a single-component state in the anaerobic treatment process, and there are several technical and technological solutions for their implementation, and they have been introduced [8,9,10,11]:

- equipment and method for long-term processing of poultry organic waste by mixing equal volumes of two and three types of organic waste,
- devices processing poultry organic waste, which is 7% of the total volume of processed organic waste mixed with multi-component organic waste,
- methods of composting and vermicomposting and drying,
- in the method of multi-component organic waste.

It is clear that there are many advantages and disadvantages of anaerobic processing methods and devices of poultry organic waste considered in the analysis. Long-term processing of poultry organic waste mixed with two and three types of organic waste in equal volume, devices and methods for processing poultry organic waste in a certain amount compared to the total volume of organic waste mixed with multi-component organic waste, and composting, vermicomposting methods for a relatively long time are the processes involved, device for obtaining renewable energy from poultry organic waste, regardless of climatic conditions, leads to a decrease in the amount of biogas obtained while keeping the content of biofertilizer at the required level.

When processing poultry organic waste with two and three types of organic waste in an equal volume, it is not possible to find an equal volume of biomass and during their constructive introduction to production, it causes the problem of finding places with sources of organic waste of such an equal composition.

From our analysis, it is economically efficient to process poultry organic waste as a single-component organic waste in a relatively short time, and the amount of commercial biogas is high while maintaining the quality of the obtained biofertilizer, but, during the use of such methods and devices, it is necessary to justify their structural and technological parameters.

4. Conclusions

Taking into account the above, it was established the parameters of the renewable energy device from poultry organic waste and the introduction of such a device. To achieve the set goal, we set the following research tasks:

- physico-mechanical analysis of the activity of microorganisms in poultry organic waste at certain temperatures and study for various processes;

- to determine the effect of the parameters (amount of dilution, mixing time and number of mixing in the bioreactor) on the quality of the obtained products during the development and preparation of an anaerobic treatment device for poultry organic waste;
- studying the physical-mechanical properties of biomass consisting of poultry organic waste in the anaerobic process;
- theoretical study of the anaerobic process in the developed biogas plant of poultry organic waste;
- conducting production experiments and determining economic efficiency indicators at the pilot plant for anaerobic treatment of poultry organic waste.
- So, when conclusions were drawn on the use of anaerobically processed poultry waste as biofertilizer, it was found that it is possible to introduce them into production without further processing according to their composition.

References

- [1] Usmanov K, Imomova N, Imomov Sh, Nuritov I and Tagaev V 2021 Analysis of laboratory results in anaerobic processing in poultry dung reduction regime *IOP Conference Series: Earth and Environmental Science* **868** 012049
- [2] Imomov S, Sultonov M, Aynakulov S, Usmonov K and Khafizov O 2019 Mathematical Model of the Processes of Step-By-Step Processing of Organic Waste *2019 International Conference on Information Science and Communications Technologies (ICISCT)*, (Tashkent, Uzbekistan, 2019) pp 1-3 <https://doi.org/10.1109/ICISCT47635.2019.9011929>
- [3] Baader V, Done E and Brenderfer M 1982 *Biogas: theory and practice* (Colossus)
- [4] Pavlenko M 2003 Infestation and yield of oat crops, depending on resource-saving tillage systems *Modern technologies for increasing the yield of grain crops: tr. / Kem SHN*. 140-8
- [5] Dai Jianjun and TsuiHeping John R Grace 2012 *Progress in the field of energy and combustion of science* **38** 716-36
- [6] Chen Y and Hashimoto A 2014 *Biotechnology and Bioengineering Symposium* **8** 269-82
- [7] Kurmanov A 2014 *Life Science Journal* **11(11s)** 24-9
- [8] Murina V I, Kislenco N N and SurkovaYu V *The technology of processing natural gas and condensate* (Bosom)
- [9] Marinenko E E 2003 *Bases of reception and use of biofuel for the decision of questions of power savings and protection of an environment in housing-and-municipal and an agriculture* (Volgograd)
- [10] Panckhava E S, Pozharnov V A and Mayorov N I 1999 *Teploenergetika* **2** 30-9
- [11] Yesenamanova M, Kuspangalieva A, Dusikenova T, Yesenamanova Zh and Tlepbergenova A 2018 *International Journal of Applied and Fundamental Research* **11-1** 85-9