



TOSHKENT IRRIGATSIYA VA QISHLOQ
XO'JALIGINI MEXANIZATSIYALASH
MUHANDISLARI INSTITUTI



FAN: MGD va KK

MAVZU

*Gidrotehnik
inshootlarini loyihalash*



Ma`ruzachi:

p.f.f.d., (Phd). U.A.Nasritdinova

Toshkent – 2020

Sirtlarni tekislik bilan kesishuvi

Sonlar bilan berilgan proeksiyalarda tekislik bilan sirtlarning kesishishi boshqa proeksiyalash usullaridagi kabi yordamchi kesuvchi tekisliklardan foydalanib topiladi. Berilgan sirt va tekislik gorizontal tekislik bilan kesiladi. Hosil bo'lgan bir hil son belgili gorizontallarning kesishish nuqtalari topiladi.

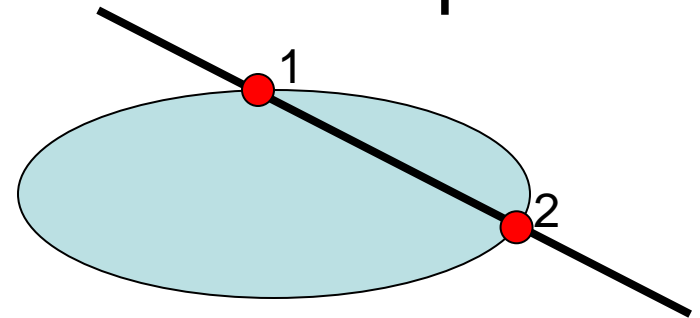

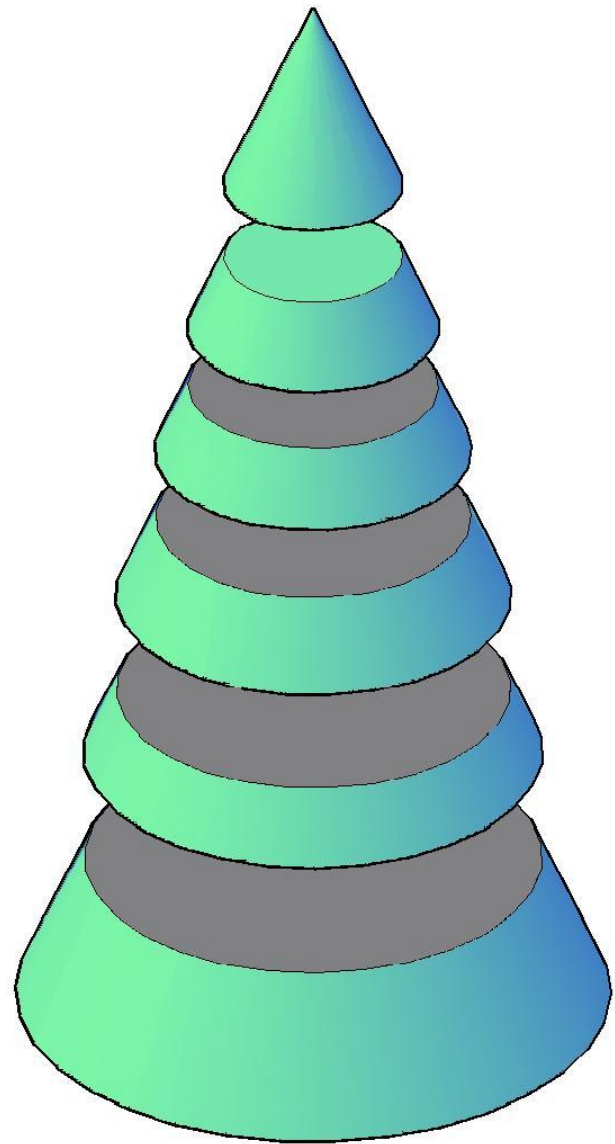
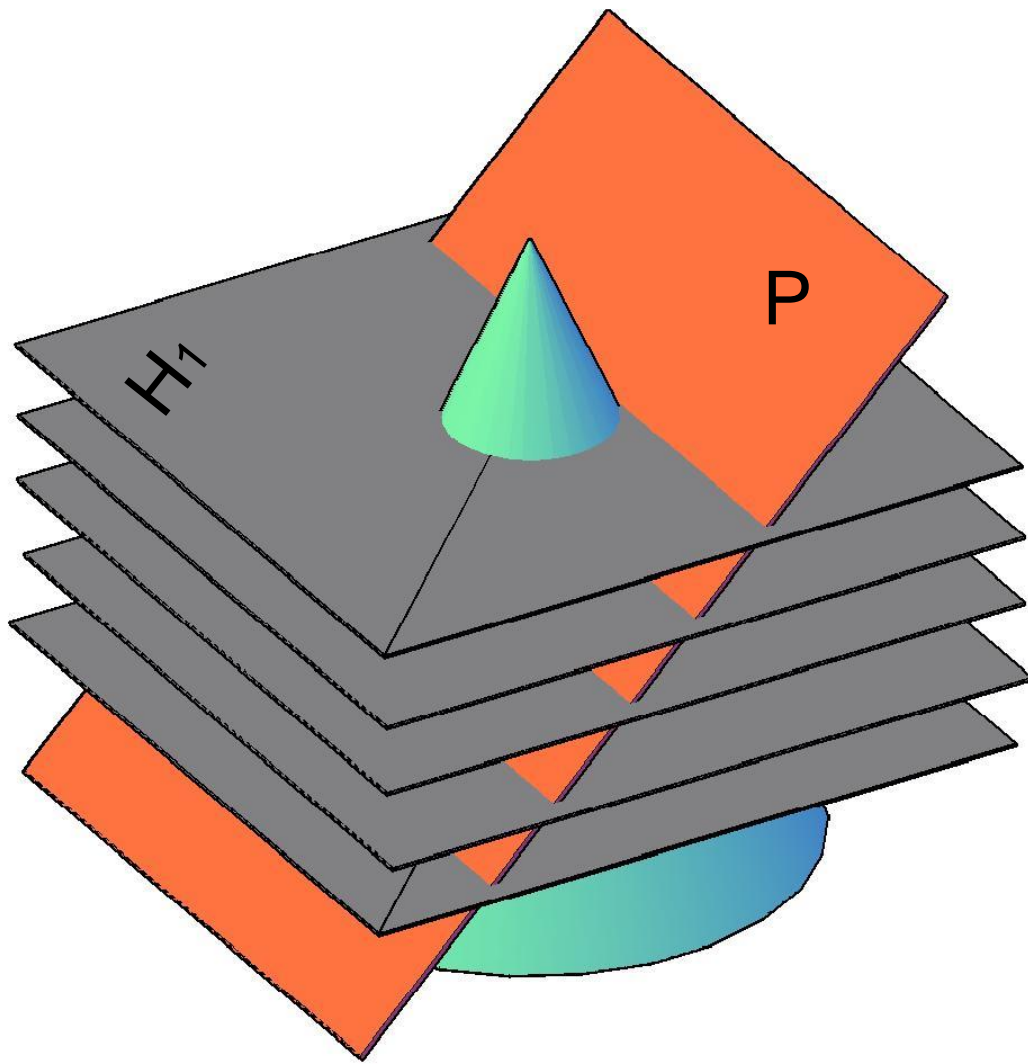

To'g'ri konusning tekislik bilan kesishuvi

- Profillanganda

Planda

7 6 5 4 3 2 1 0

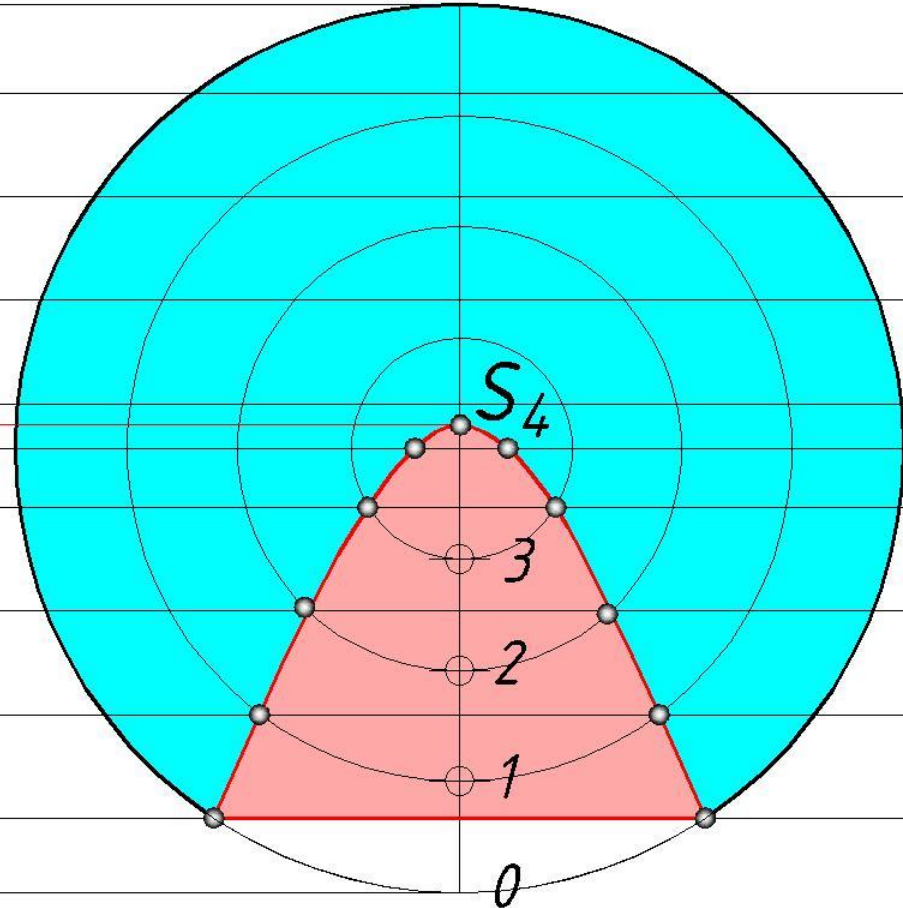
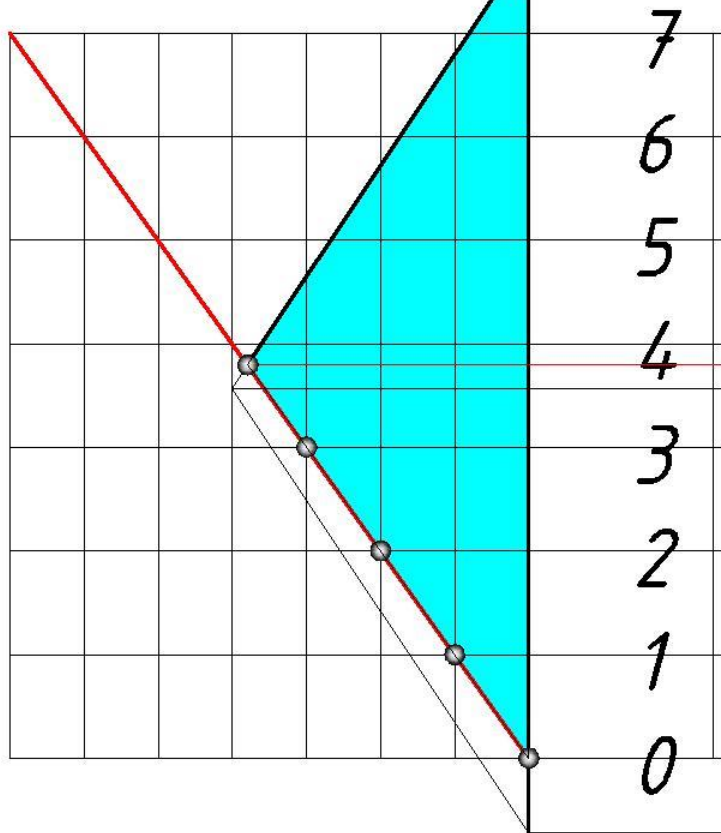

Og'ma konusning tekislik bilan kesishuvi

- Profillanganda

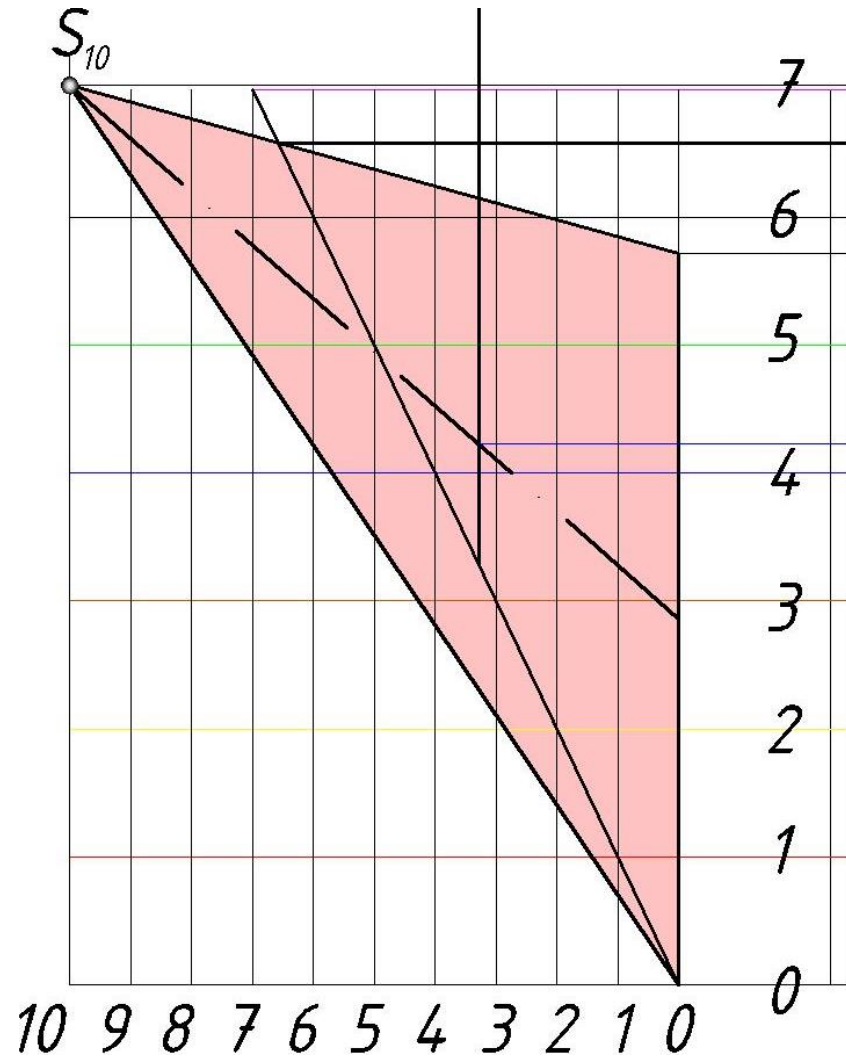

Planda

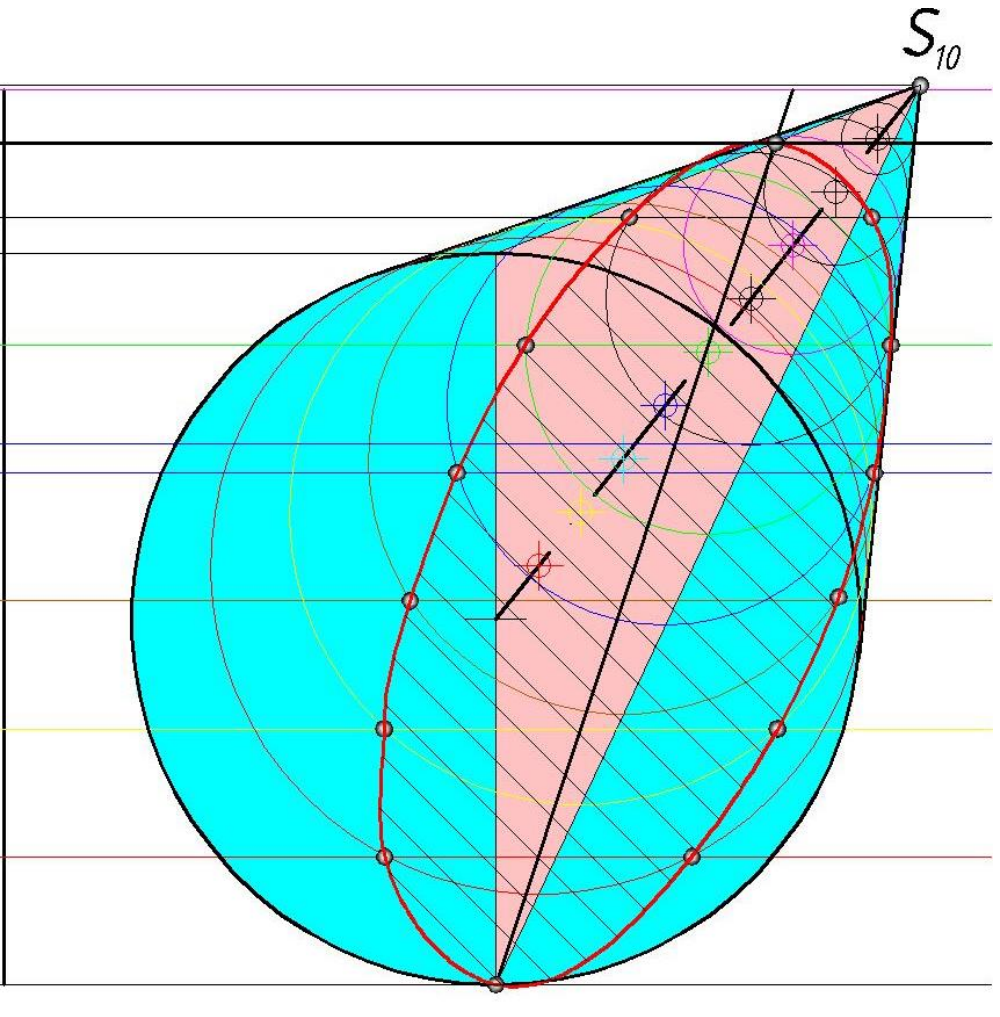

Og'ma prizmani tekislik bilan kesishuvi

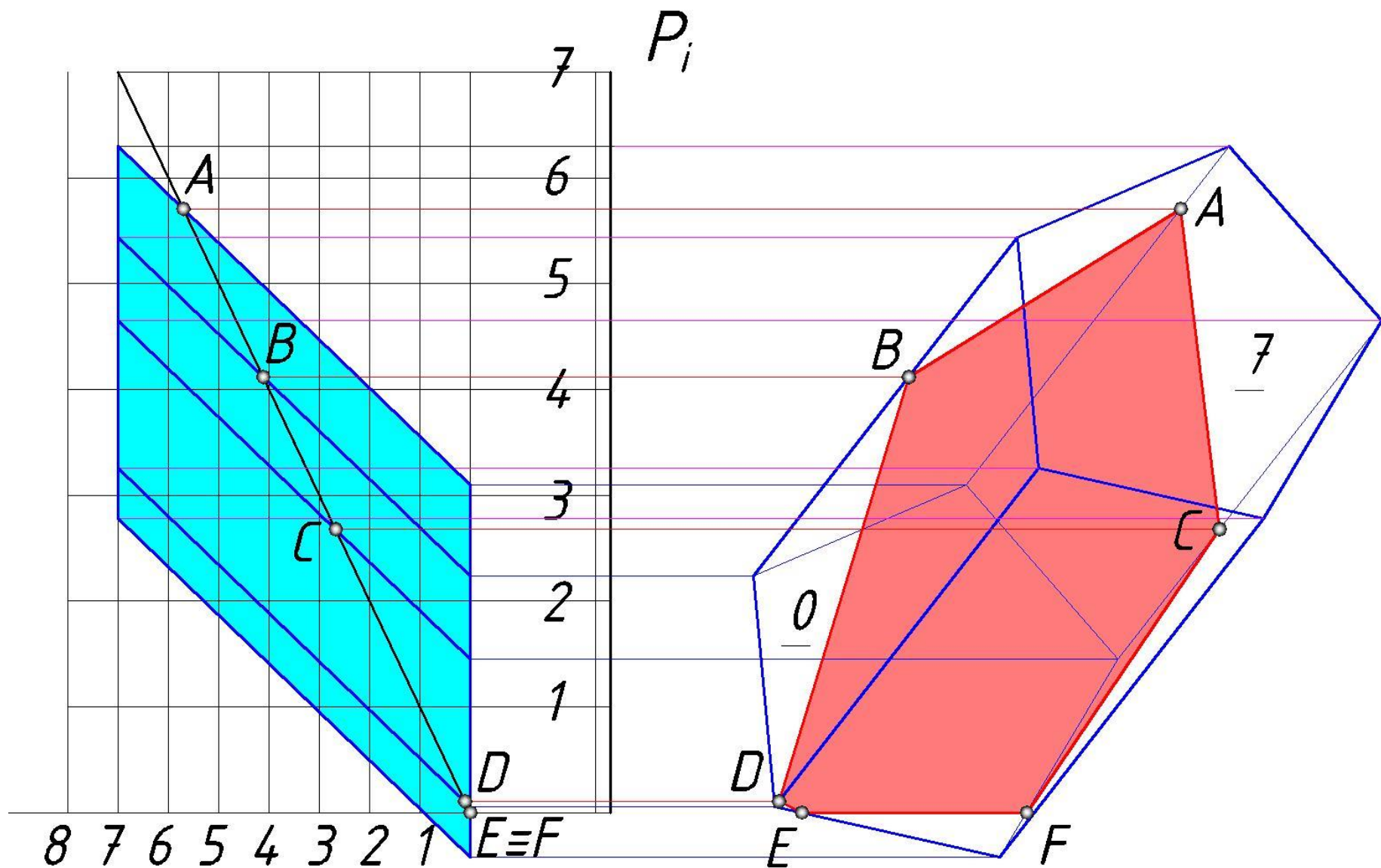

Kotlovan yonbag'ir tekisliklarining berilgan tekislik bilan kesishuvi

- Kotlovan konturiga perpendikulyar qilib qiyalik masshtablari o'tkaziladi.
- Qiyalik masshtablari darajalanadi.
- Yonbag'ir tekislikning gorizontallari o'tkaziladi.

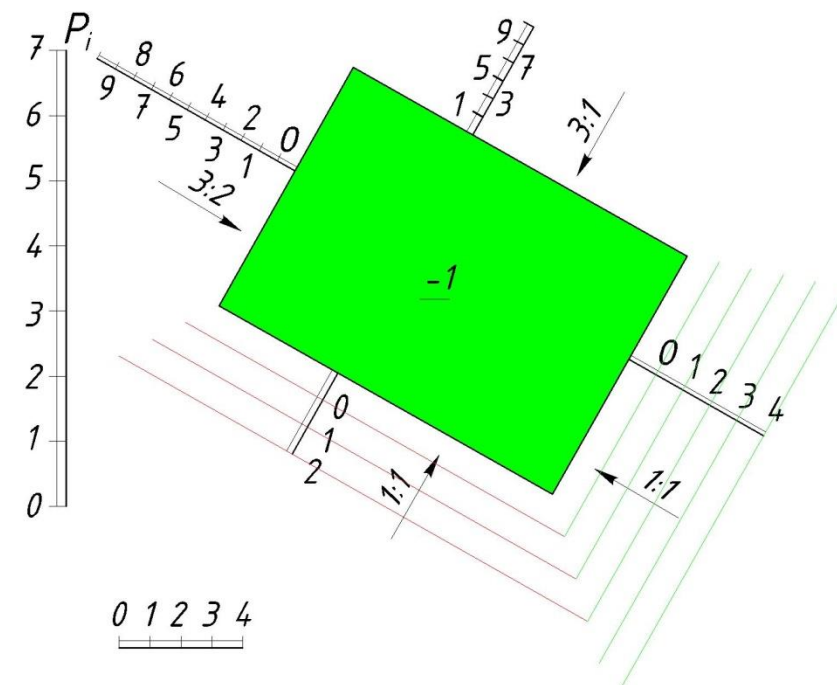
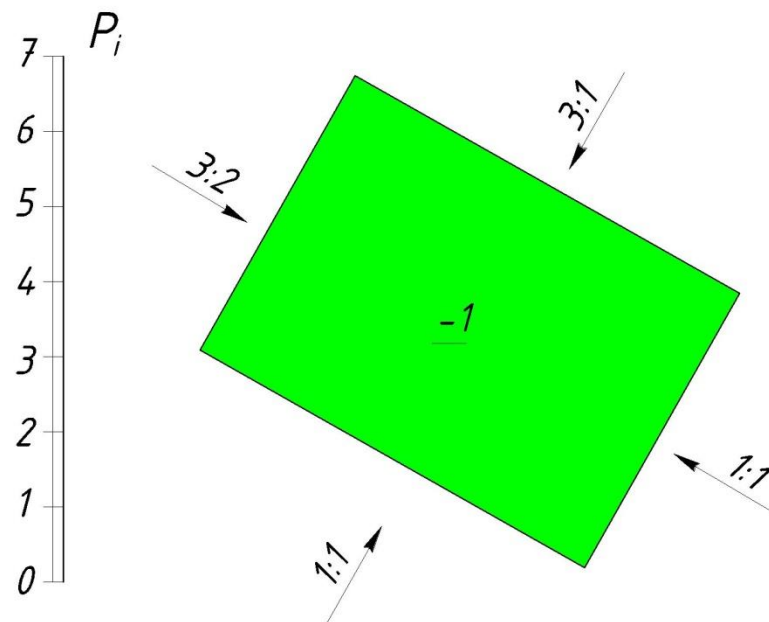

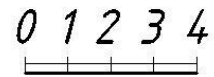
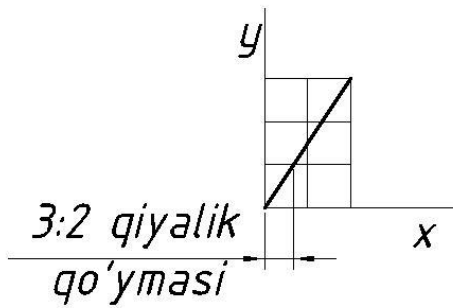
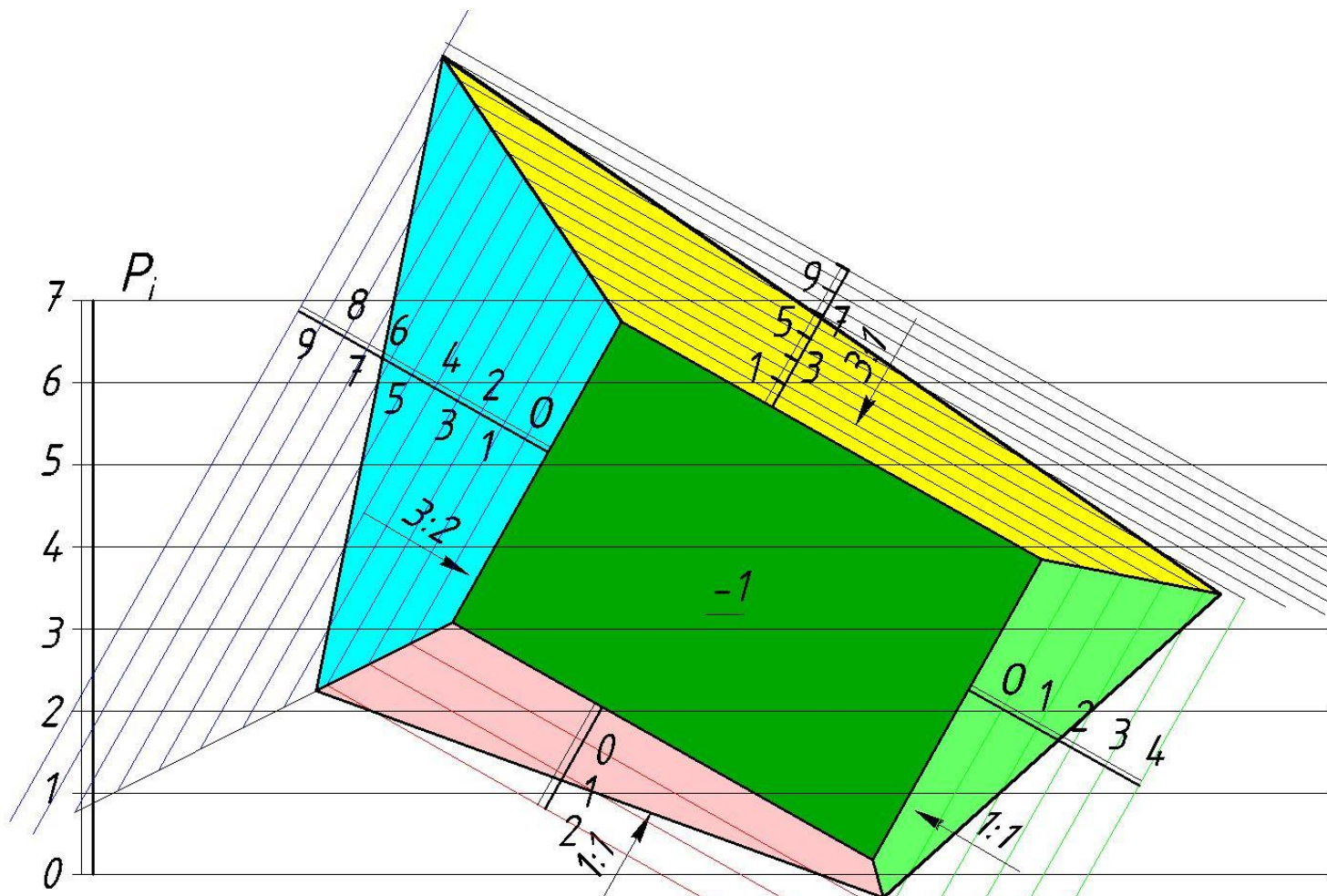

To'g'ri chiziqni topografik sirt bilan kesishuvi

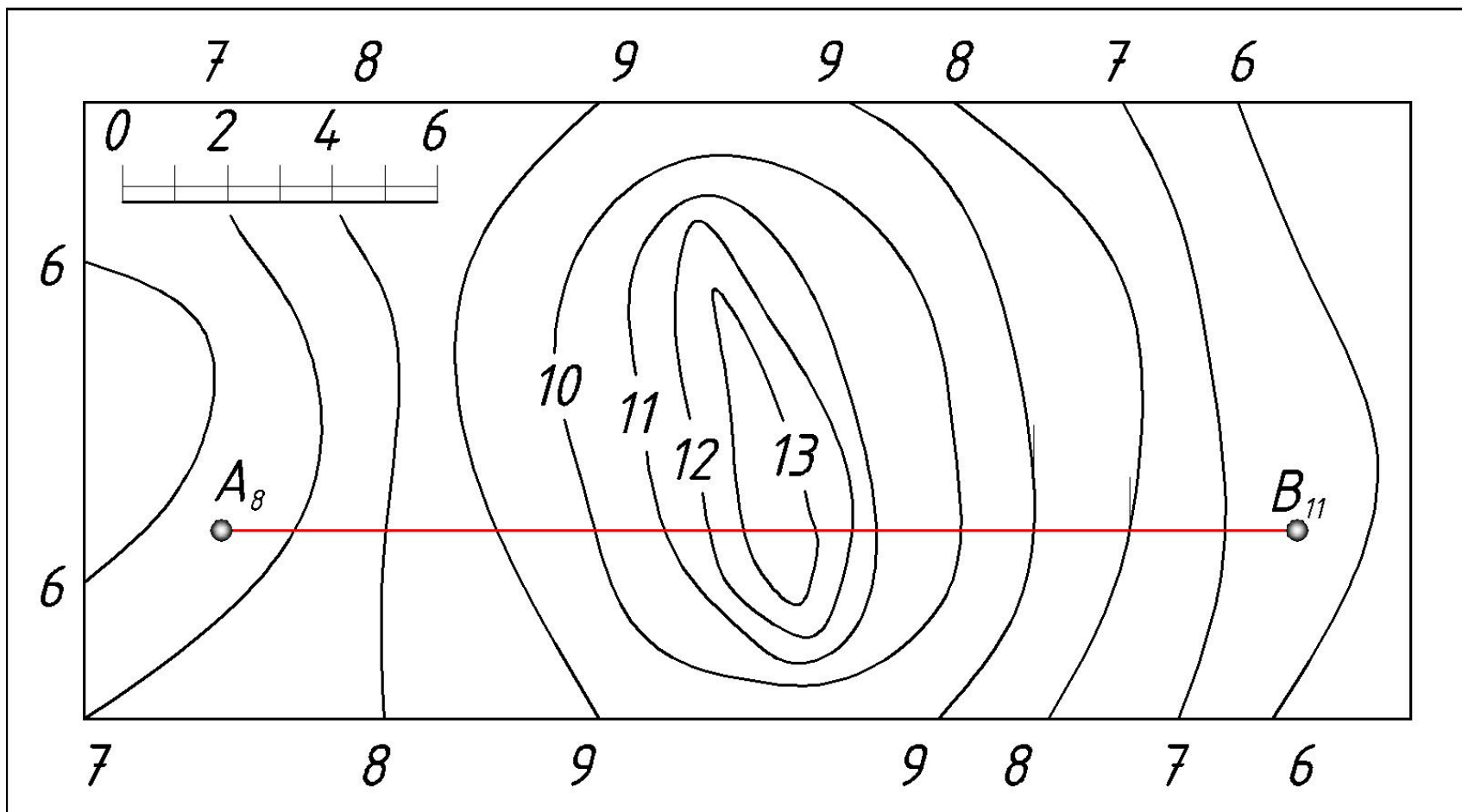

To'g'ri chiziqni topografik sirt bilan kesishuvi

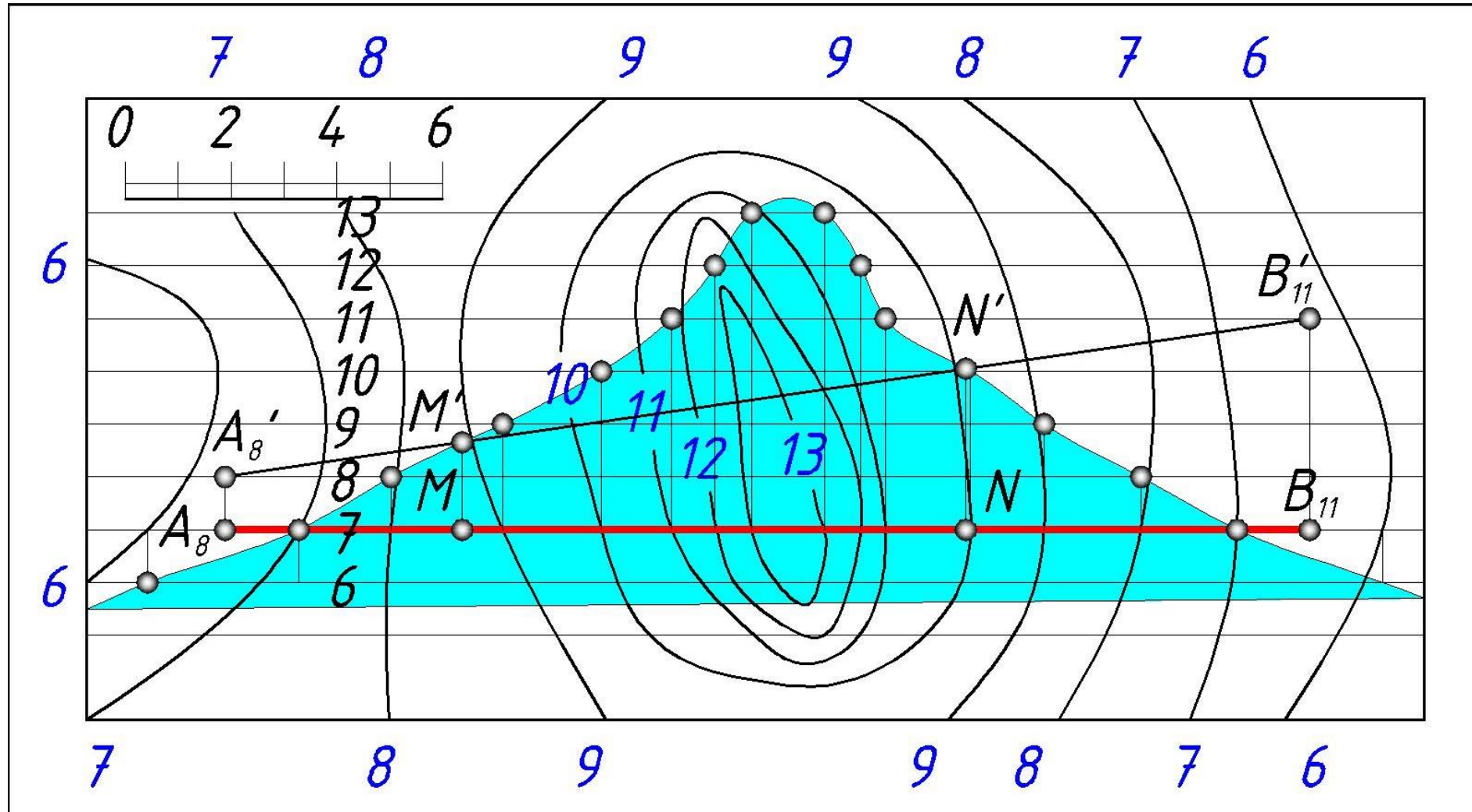

Tekislikni topografik sirt bilan kesishuvi

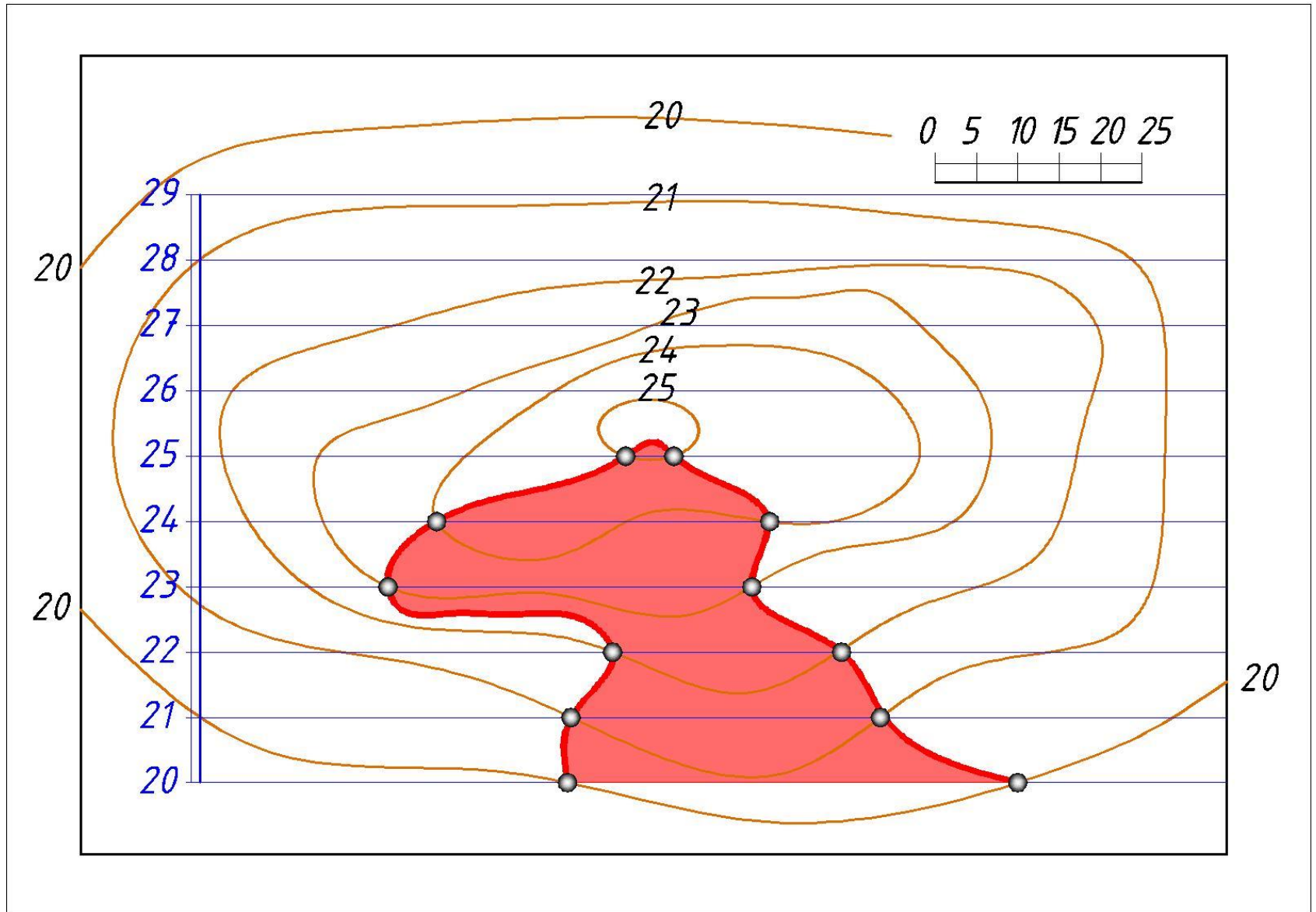

Maydoncha chizmasini bajarish bosqichlari

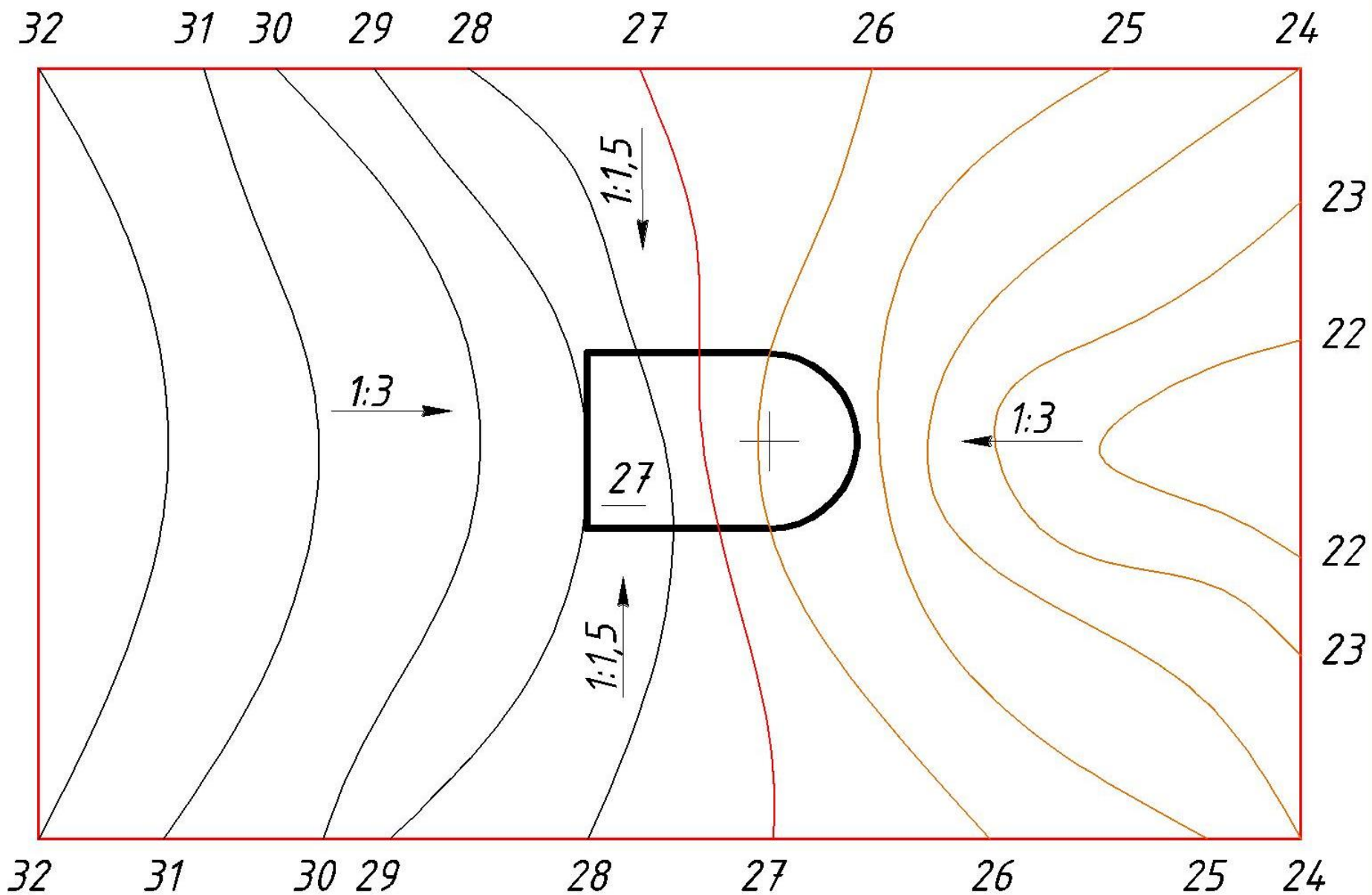

32 31 30 29 28 27 26 25 24

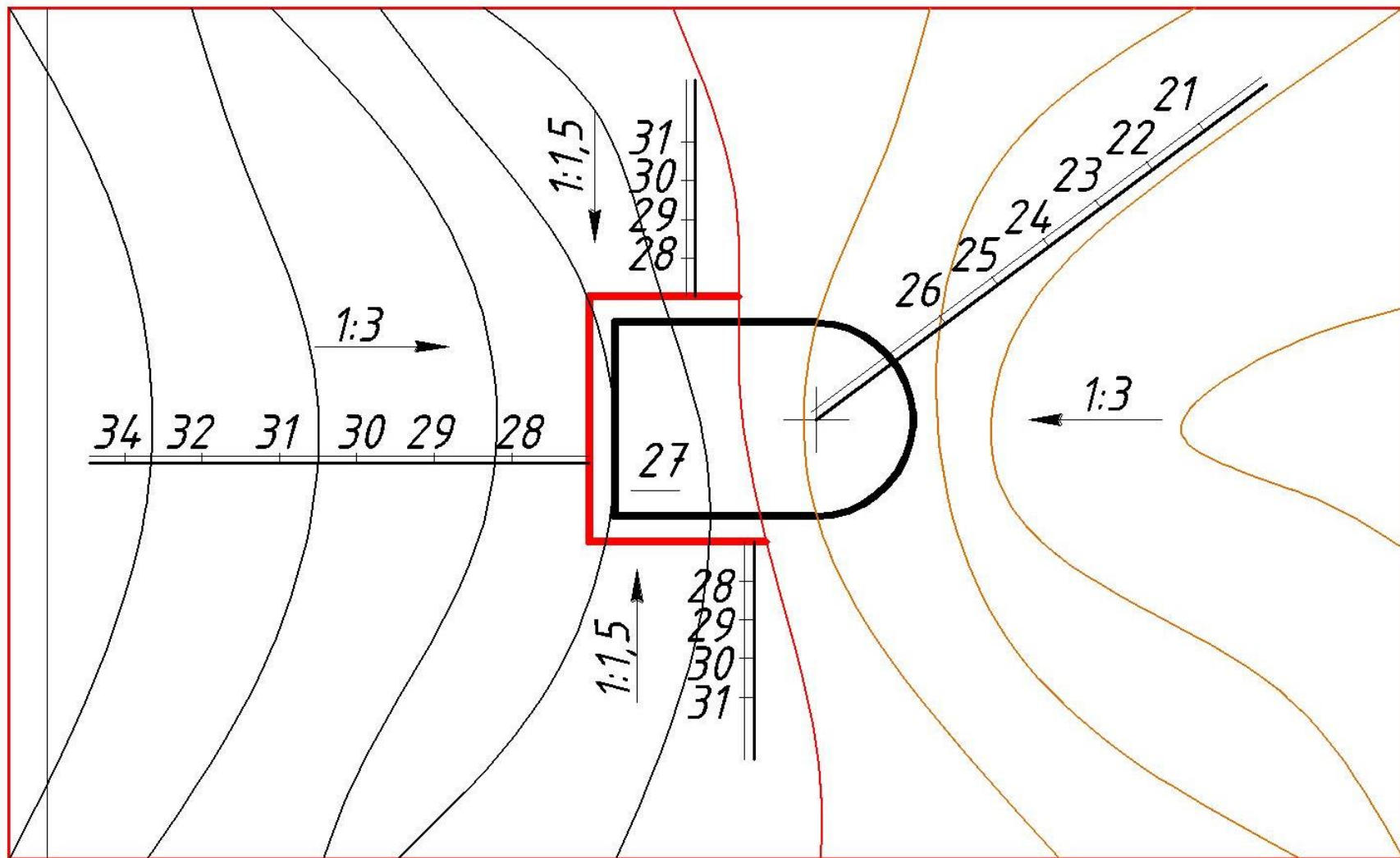

32 31 30 29 28 27 26 25 24

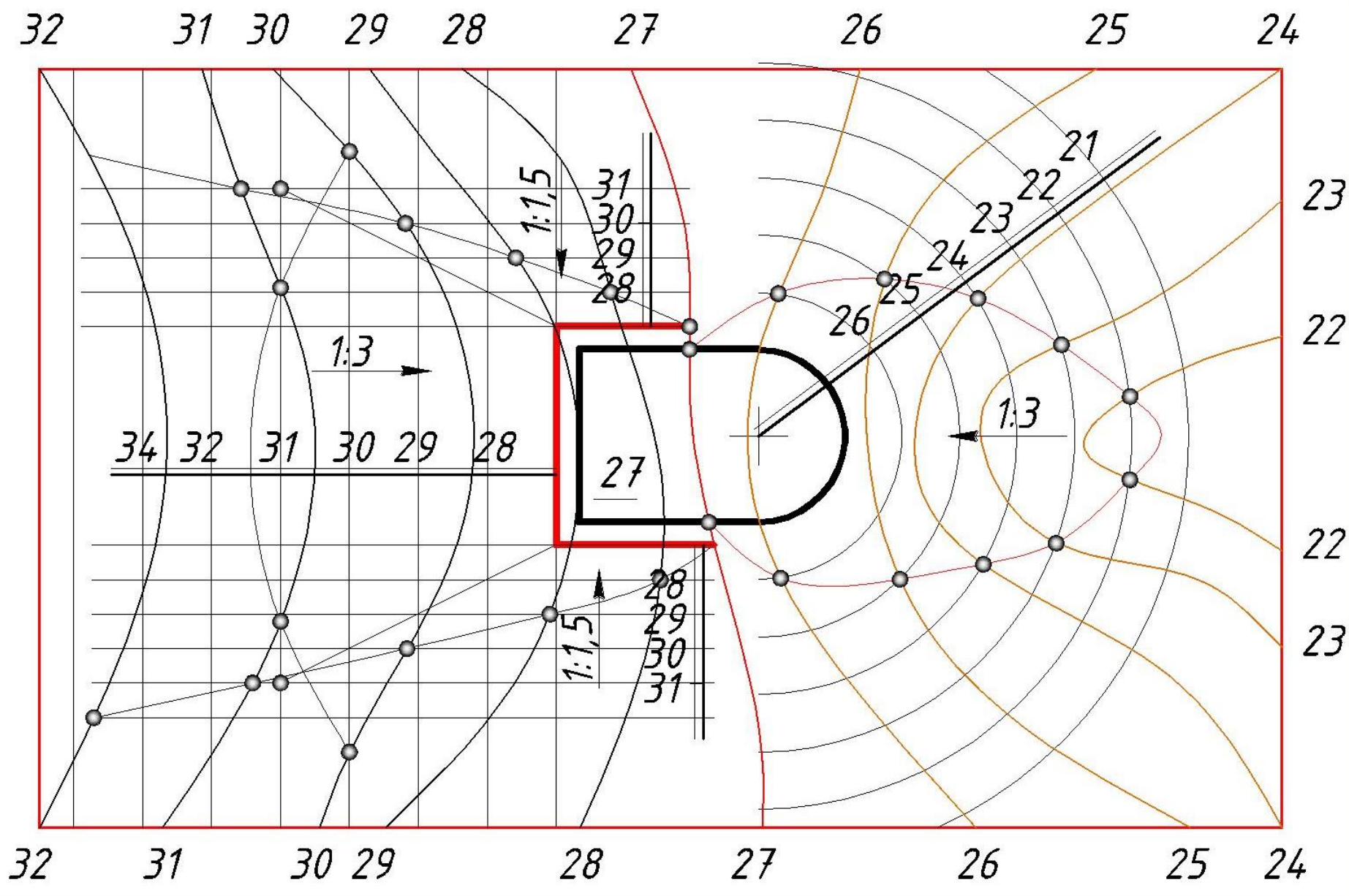

32 31 30 29 28 27 26 25 24

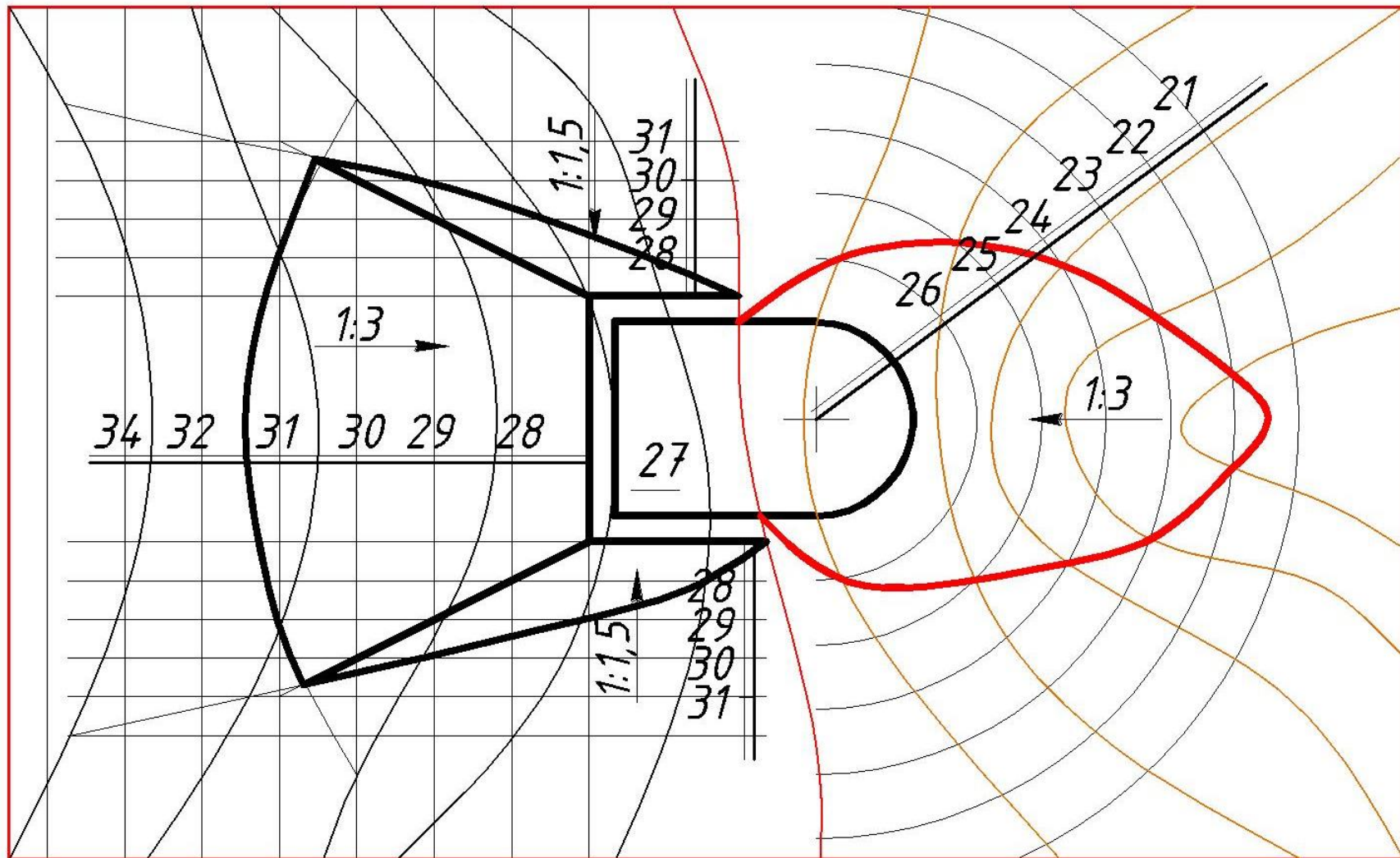

32 31 30 29 28 27 26 25 24

32 31 30 29 28 27 26 25 24

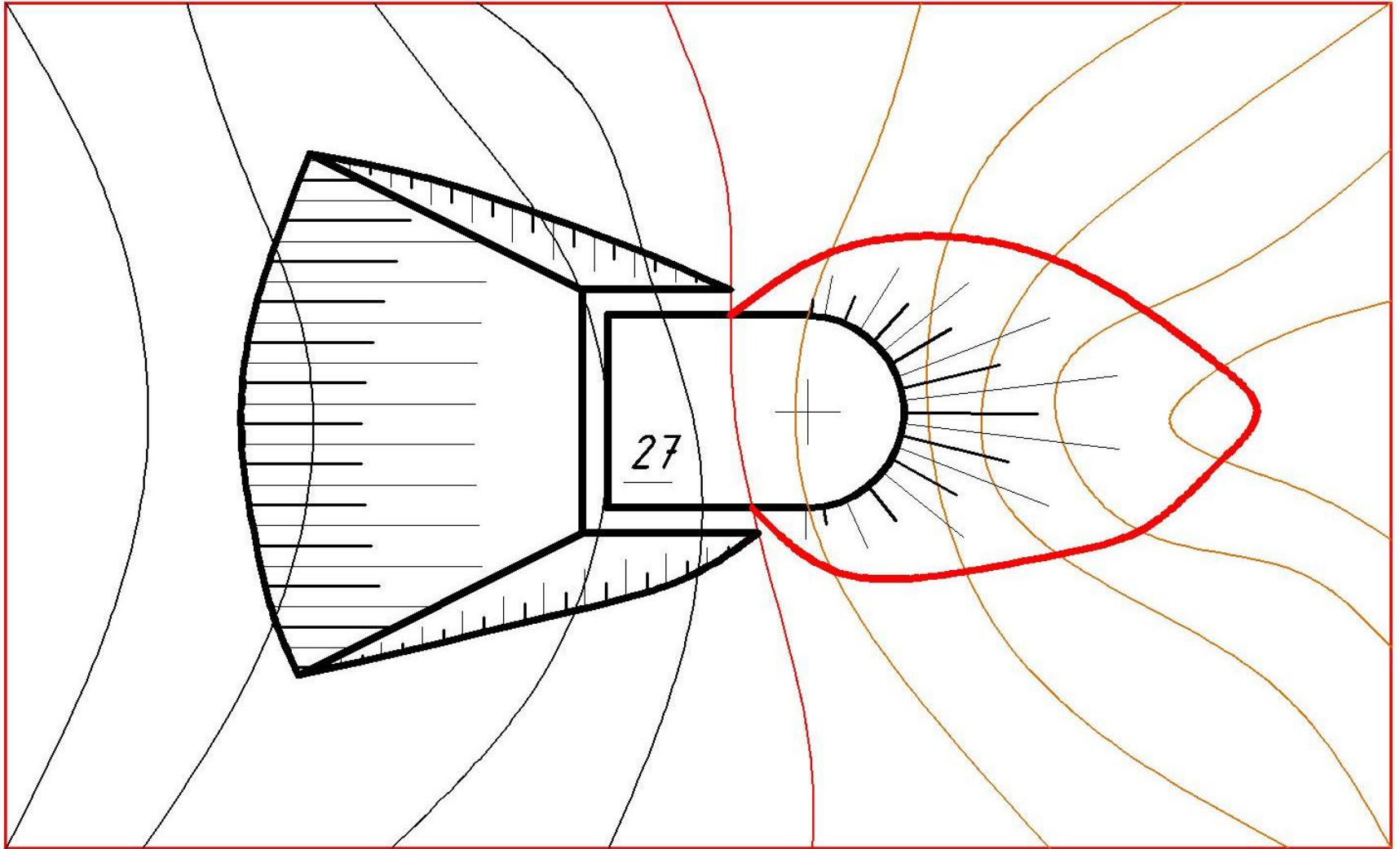

23

22

22

23

32 31 30 29 28 27 26 25 24