

PAPER • OPEN ACCESS

Peculiarities of digging topinambur (Jerusalem artichoke) tubers on the irrigation lands of Uzbekistan

To cite this article: M Shoumarova *et al* 2021 *IOP Conf. Ser.: Earth Environ. Sci.* **868** 012041

View the [article online](#) for updates and enhancements.

You may also like

- [Products of processing of Jerusalem artichoke for enrichment of food systems based on resources of rabbit breeding](#)
E E Kurchaeva, Yu A Safonova, I V Maksimov *et al.*
- [Effect of Addition of *Lactobacillus reuteri*, inulin and Jerusalem Artichoke \(*Helianthus tuberosus*\) Powder in Diets of Common carp \(*Cyprinus carpio* L.\) on Growth Performance and Feed Utilization](#)
H. S. Abedalhammed, A. A. Yassen, B. A. Khashan *et al.*
- [Effect of Addition of Jerusalem Artichoke \(*Helianthus Tuberosus*\) Tubers Powder, and Inulin on *Lactobacillus Reuteri* Activity and Recovery After Freezing Injury](#)
Ali A. Yaseen, Bilal A. Khashan, Anmar N. Hasan *et al.*



245th ECS Meeting • May 26-30, 2024 • San Francisco, CA

[Learn more & submit!](#)

Present your work at the leading electrochemistry & solid-state science conference.

Network with academic, government, and industry influencers!

Submit abstracts by December 1, 2023



Peculiarities of digging topinambur (Jerusalem artichoke) tubes on the irrigation lands of Uzbekistan

M Shoumarova, T Abdillayev, Sh Yusupov*

Tashkent Institute of Irrigation and Agricultural Mechanization Engineers, 39, Street Kari Niyaziy, Tashkent, 100000, Uzbekistan

E-mail: sher_xxx89@mail.ru

Abstract. Jerusalem artichoke crops, as a new crop in irrigated agriculture in Uzbekistan, are expanding more and more. Scientists have developed many recipes for using Jerusalem artichoke tubers in the form of food additives that help improve the quality of bakery products, sausages, and various drinks. The pharmaceutical industry uses Jerusalem artichoke for the manufacture of medicines, in the chemical-technological industry, high-quality cellulose is obtained. In agriculture, it is used as a quality animal feed. Therefore, it is required to mechanize the entire cycle of its cultivation. The most time-consuming process is the harvesting of tubers. To dig up Jerusalem artichoke tubers, ordinary potato diggers are used, which are not adapted to dig up the tubers formed under the bottom of the irrigation furrows. The article provides materials on the adaptation of a potato digger for digging up Jerusalem artichoke tubers by installing a special ploughshare on it. Such a share has a complex working surface, adapted for more complete digging of tubers from under the irrigation furrow, reducing losses to 5 percent or less of the grown crop. Such a share must have an increased working width, which makes the process of its operation energy-intensive. Therefore, the authors propose to make a ploughshare from longitudinal strips - grates, when a part of the soil will be separated through their open intervals, facilitating the process of separating the soil from the tubers. Field experiments with such plowshares have shown their effectiveness.

1. Introduction

The cultivation of Jerusalem artichoke has been rapidly expands in Uzbekistan in recent years. As it is known, this plant is unpretentious, does not require abundant watering. It can grow in slightly and moderately saline soils. Its stems are excellent animal feed, and the tubers are rich in elements useful for humans. The tubers are used in the pharmaceutical industry for the extraction of inulin, which successfully cures diabetes mellitus [1]. Tubers ennoble sausages, bakery products, drinks, and other products [2]. Experts in the pharmaceutical, chemical-technological, food industries have developed original recipes for using Jerusalem artichoke to improve the health of the population of Uzbekistan.

To mechanize the processes of Jerusalem artichoke cultivation, it is permissible to use machines for irrigated agriculture in the Republic: plows for basic soil cultivation, various machines for fertilizing, preparing fields for sowing Jerusalem artichoke. For the first and second cultivation of Jerusalem artichoke crops, it is quite possible to use cotton cultivators. Potato planters are used for sowing. Various forage harvesters can be used to mow the stems before harvesting the tubers. Potato diggers are used to dig up tubers. Thus, almost all work in the cultivation of Jerusalem artichoke can be carried out with existing machines in the Republic.



Content from this work may be used under the terms of the [Creative Commons Attribution 3.0 licence](https://creativecommons.org/licenses/by/3.0/). Any further distribution of this work must maintain attribution to the author(s) and the title of the work, journal citation and DOI.

However, we found that when cultivated in irrigated agriculture, tubers are located not only in the ridges but also under the irrigation furrow. Part of the tuberous roots, in search of more moist soil, develops towards the bottom of the irrigation furrow. This difference from non-field plantations forced us to make some constructive changes to the plowshare of the existing potato digger. Therefore, this article outlines the essence of these improvements.

2. Review of previous research

Features of Jerusalem artichoke are highlighted enough in the available literature. In many foreign countries, Jerusalem artichoke is cultivated in fairly large areas [3, 4, 5]. In Uzbekistan, this culture is considered new, only now the areas allocated for the sowing of Jerusalem artichoke are increasing. But the scientists of the Republic have thoroughly studied the properties of Jerusalem artichoke and developed technologies for its processing. The most valuable property of Jerusalem artichoke is that it contains a lot of inulin, which is successfully used by the pharmaceutical industry [5, 6, 7, 8, 9, 10]. Therefore, she consumes a lot of Jerusalem artichoke tubers as cheese.

Scientists in the chemical engineering industry have developed a technology for producing high-quality cellulose from Jerusalem artichoke stems[11, 12, 13, 14]. Food industry experts have developed recipes for adding tuber powders to bakery products, which is why their taste has improved significantly and is stored longer. There have even been developed ways of using Jerusalem artichoke to make several healthy drinks, to improve the quality of sausages.

Jerusalem artichoke is also widely used in the agriculture of the Republic. Tubers, as well as crushed stems, are added to various feeds in animal husbandry. It has been found that this improves the weight gain of the animals and increases the amount of milk.

The breeders of the Republic have created local zoned varieties "Fayz Baraka" and "Muzhiza", which can withstand summer frying[15, 16]. These varieties differ from the parent varieties in that their surface is smoother, do not have different shapes and sizes of shoots. These varieties are easier to clear of soil, which makes it easier to dig them out and harvest.

3. Digging up tubers

Jerusalem artichoke is harvested in late autumn, therefore, due to autumn precipitation, soil moisture can reach 25-30%, which makes harvesting difficult. Before digging out the tubers, the stems should be removed, which can be up to 2.5-3.0 m high. Otherwise, the long stems complicate the harvesting process. The stalks are harvested by forage harvesters and taken out of the field. After 5-7 days after mowing the stems, they begin to dig up tubers, and the cutting height is 15-20 cm. If the cutting height is too low on the separating lattice elevators, the loss of tubers through the trellised surface, along with the remains of the stems, increases[17, 18, 19, 20, 21].

In Uzbekistan, elevator-type potato diggers are used to dig up tubers. The digger digs out tubers with the remains of stems, separates the soil on the elevators, the tubers cleaned from the soil with the remnants of the stems are unloaded onto the field and left in the form of a roller in an open state. The workers then manually pick the tubers from the swath and collect them in boxes.

In small areas, the tubers are dug up by hand. But when harvesting by hand, large losses of tubers are observed, because, it turns out, in irrigated agriculture, the tuberous roots of Jerusalem artichoke, in search of more moist soil areas, often give birth to tubers under the bottom of the irrigation furrow (Figure. 1). When manually digging with the help of ordinary shovels, workers remove the tubers only from the rowing room, the tubers that have appeared under the furrow are left untouched. This increases the share of losses to 15-18% of the grown crop. In some circumstances, the total loss of tubers can even go up to 20%. This is also facilitated by the fact that the color of the skin of the tubers does not differ much from the color of the soil in our region, therefore, with the manual collection, the probability of mistakenly missing part of the tubers increases. In addition, tubers are harvested in late autumn, when, before autumn precipitation, harvests of vegetable and fruit crops are also urgently harvested by hand, i.e. during the period of labor shortage.

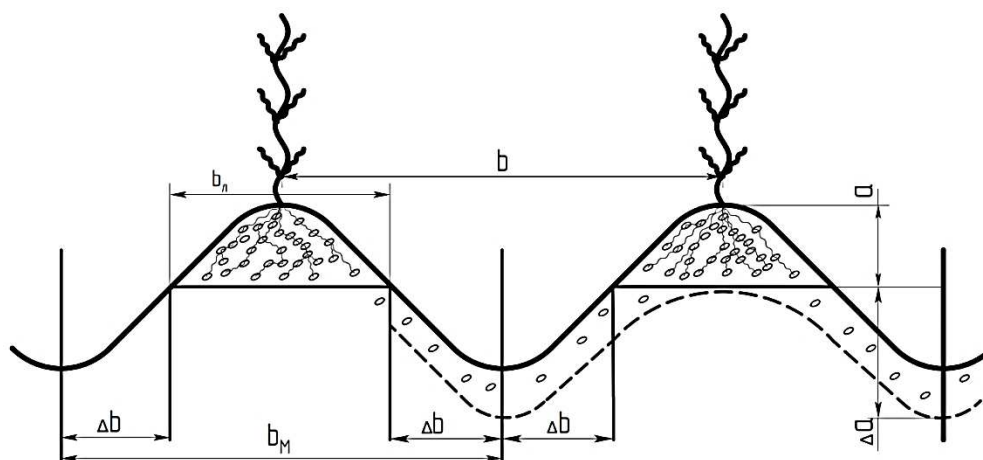

Figure 1. Scheme of placement of Jerusalem artichoke tubers both in the ridge and under the bottom of the irrigation furrow.

Therefore, we believe that it is advisable to introduce more widely the mechanized harvesting of Jerusalem artichoke using potato diggers, after some alterations concerning local conditions. Working width b_l of the excavating share of the existing elevator potato digger is sufficient for complete digging of tubers grown in the ridge, setting the digging depth to 16-18 cm (Figure 1). In this case, if the row spacing is $b = 70$ cm, then an untreated strip with a width of $2\Delta b = 100$ mm remains between the shares of adjacent ridges. As it is noted above, part of the tubers may remain intact under the $2\Delta b$ strip. Therefore, we considered that in irrigated lands the width of the share should be $b_l + 2\Delta b$, i.e. $b_l + 100$ mm.

In addition, a plowshare with a width $b_l + 2\Delta b$, must not be flat. Because, for a more complete digging of all tubers from under the bottom of the furrow, the share should be buried to a depth of $\alpha + \Delta\alpha$, which is why the volume of soil that should be separated from the field and raised up to the elevator will be very large. Such digging would be excessively energy-intensive. Therefore, the front part of the share with the blade should not be flat, but curved, as shown in Figure 2. The curvature of the plowshare blade should repeat the curvature of the locations of all tubers, the depth of their location from the ridge to the bottom. Consequently, the front half of the plowshare should be bent in the form of the base of a cone with a peaked O_1 . The curvature of the blade (section C-C in Figure 2), as already mentioned, should repeat the lower level of placement of tubers in the ridge.

The plowshare is installed obliquely forward at a low angle so that the soil layer with tubers, sliding along the plowshare, can rise to the bar elevator, which will begin to intensively destroy the layer, separating the soil down. To ensure the transfer of the formation to the bar elevator, the second, i.e. the rear part of the share is made flat (Figure. 2, section A-A). Of course, such a share is heavy, especially with a large volume of the soil layer, it experiences bending deformation. To prevent deformation of the share, the lower part is laid on a firm bed. To ensure strength, in addition to the above, the right and left flat edges of the share are equipped with an edge 6.

It was said above that the volume of soil moving along such a share will be quite large, therefore, it will be advisable to use such a share on light soils. In order to reduce the volume of the soil moved along the plowshare, it was conceived to make it with a grate, i.e. install the grate bars along the generatrices of the cone-shaped surface, leaving an open space between them and asking for the soil to be separated through it (Figure. 2). The gap between the grates was set taking into account the size of the small part of the tubers. However, the gap between the grates turns out to be narrowing, which is why the cut B-B (Figure. 2) can be clogged with moist soil. Therefore, it was decided to install the grate, not along the generatrix of the conical surface, but parallel to the direction of movement of the machine. (Figure. 3)

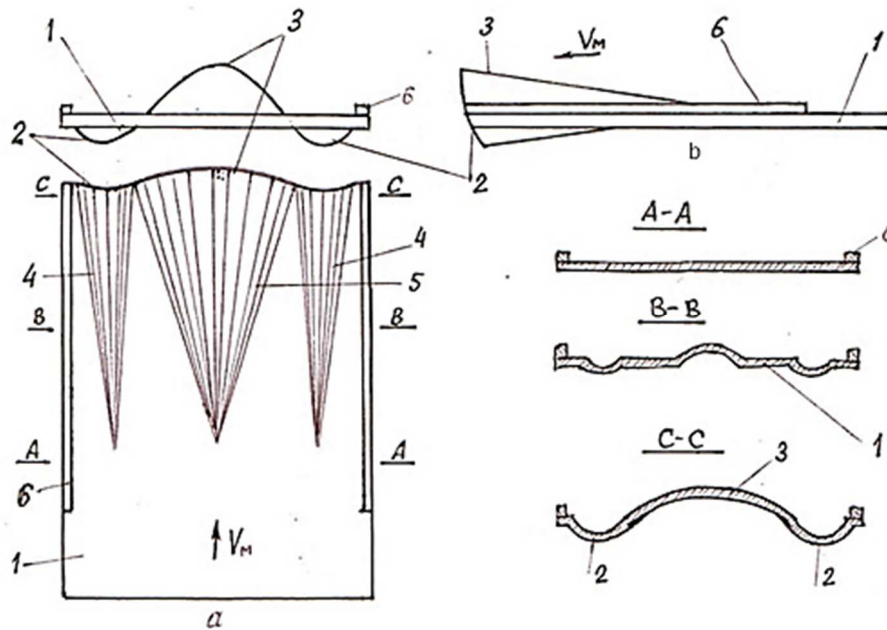

Figure 2. Scheme of a general view of a share adapted for digging up Jerusalem artichoke in irrigated agriculture: a - top view, b- side view, 1- flat part, 2-downward curved part of the blade, 3- curved upward part of the blade, 4, 5- forming conical surfaces, 6 - stiffeners.

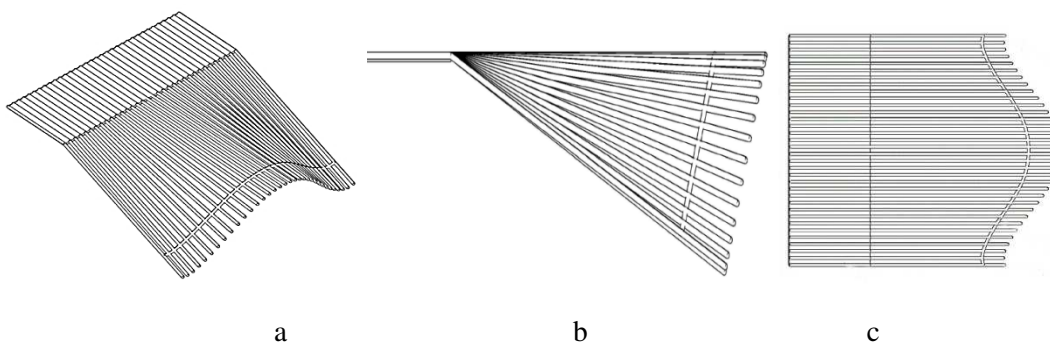

Figure 3. General view of the grate share (a), its top view (c) and side view (b).

The front ends of the grate rods are located along a curve that is consistent with the lower border of the tubers (Figure. 1) both in the ridge and under the irrigation furrow (Figure. 4). The rear ends of all grates are in the same horizontal plane to transfer the soil layer to the flat elevator.

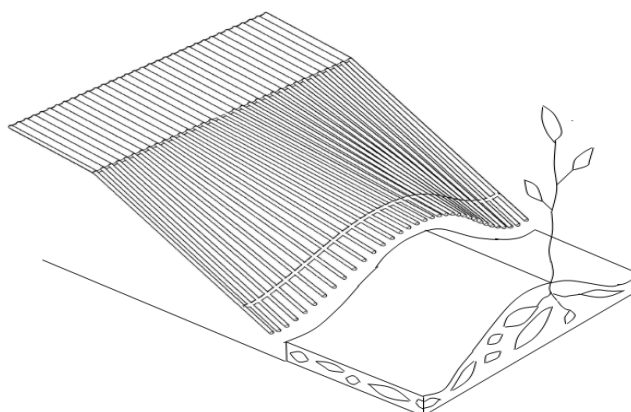

Figure 4. Scheme of matching the form of placing the front ends of the grate with the placement of tubers in height

Grizzly grates with a circular cross-section with a diameter of 14 mm were chosen. An open gap 20 mm wide was left between adjacent grates. To increase the strength of the entire structure, a plate is welded to the front ends of the grate from the bottom side along the entire width of the share (Figure. 4). Figure 5 shows the standard and grate plowshare.

The blade of such a share is intermittent and rather thick. Because it is installed obliquely at an angle less than the angle of friction with the soil, when the unit moves, the layer with tubers will rise up to the elevator. Therefore, the layer breaks off along the bend line, while a significant part of the soil, being crushed, is sifted already on the plowshare. Energy costs are reduced noticeably.

Cantilever columns in the vertical plane are inclined at different angles α . Two middle grates are installed as a continuation of the plowshare base plane. The grates to the left and right of the middle ones are set symmetrically at the same angles α . The grates are the same length, but curved at different angles, increasing towards the right and left edges. Therefore, bend the extreme grates as much as possible, so their horizontal projections seem to be short.

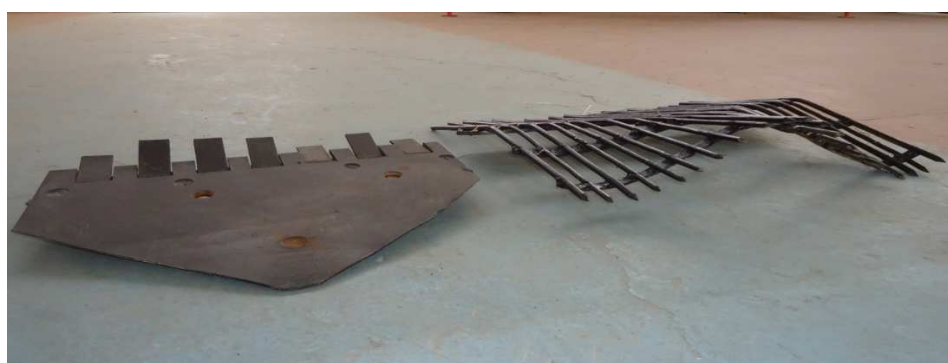

Figure 5. Standard and grate plowshares

Thus, the consideration of a plowshare made of grate bars, the cantilever ends of which form a ridge-like con Figure, makes it possible to more fully dig up Jerusalem artichoke tubers, which originated both in the ridge and 4 under the irrigation furrow with a decrease in the energy intensity of the machine.

The field experiments were carried out in the spring in the following order. For the experiments, the farm allocated a part of the field 24-25 m long and 200 m² in area. The field is sown with a row spacing of 0.70 m. The stems at a height of 15-18 cm were cut by hand. A two-row elevator potato digger was tested, on which two grate plowshares were mounted. In this part of the field, three sections of 3 m in length were selected, where the sizes of furrows and ridges, as well as the density of plants, were visually comparable.

Each three-meter section was prepared as follows (Figure. 6).

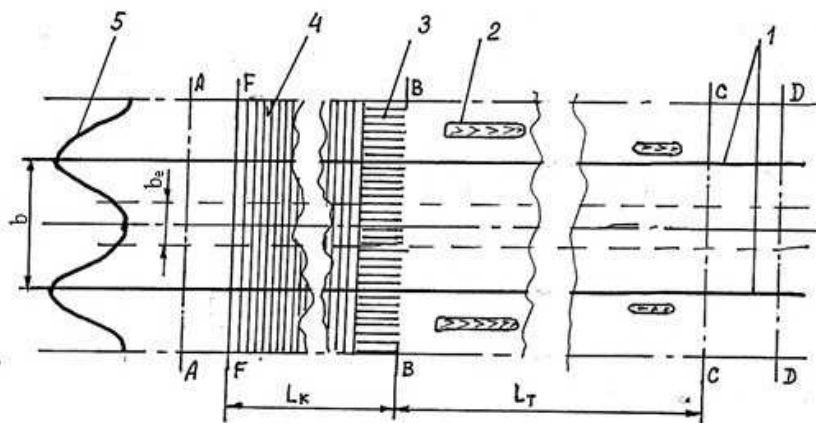

Figure 6. Scheme of preparation of experimental sections: 1-axis of symmetry of the ridge; 2-wheel tractor; 3-grate plowshare; 4-bar digger elevator; 5-cross section of rows

In five places (outside the experimental plots), tubers were manually dug up to the entire depth of their placement, i.e. there was the greatest depth of tubers under the furrow (Figure. 7). The ratio of the mass of the club from the ridge and from under the bottom is 5: 2, i.e. 74-79% of the yield was formed in the ridge, and 21-26% - under the bottom of the furrow. Tubers in the ridge at a depth of $h_p = 12$ cm, and under the furrow $h_e = 8$ cm. Using the tractor attachment, the depth of the plowshares was set to 20-22 cm under the bottom of the furrow (the depth at the ridge would be 12 cm).

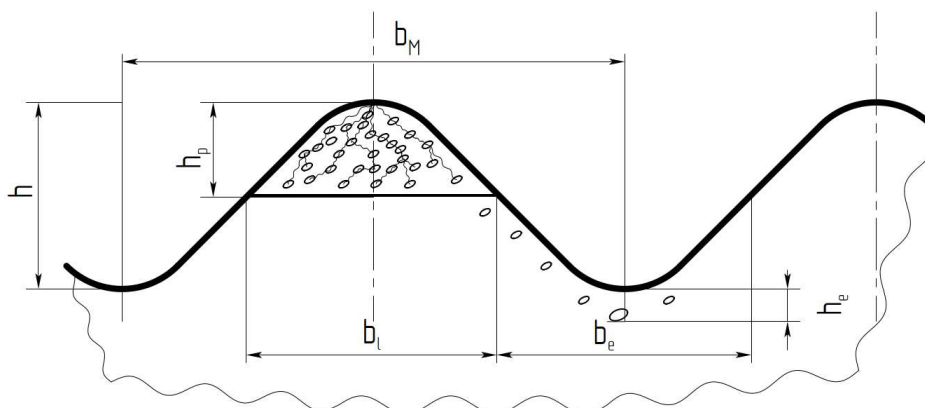

Figure 7. The scheme for determining the dimensions of the experimental section: b_M - the width of the row spacing; b_l - ridge section width, determining depth h_p - tuber occurrence; b_e - the width of the bottom of the furrow, where can the tubers be located; h - ridge height; h_e - the depth of tubers under the furrow bottom.

On the length A-B of the section, the tubers were harvested by hand over a length of 1.5 m. This is done because when the digger is working, it is planned to harvest tubers along the length of C-A without stopping the unit. After the digger leaves the C-B, tubers will continue to flow from the digger elevator to the surface of the field, which will then be manually collected and taken into account. On the part of the C-D plot, the crop is also harvested completely by hand before the experiments. buried in the soil, the position is established after the D-D border.

The harvest along the length B-C is harvested by a digger. The digger leaves all the tubers on the surface of the field and then handpicks them for weight. It was said above that adjacent plowshares to work with some overlap to remove tubers with width b_e (Figure. 7). After the digger passes through the area, the soil is manually dug out approximately at the width of the bee and the tubers left under the bottom of the furrow are collected for accounting.

As a result of the experiments, it was revealed that the prototype of the grate share digs up to 92-94% of the tubers from the bottom of the furrow. The overall rate of digging (extraction to the surface of the field) was even up to 95% of the harvest.

Thus, field experiments have shown that the use of grate plowshares is advisable. However, for the operation of these plowshares, it is necessary to allocate fields that are not clogged with weeds.

4. Conclusion

During the cultivation of Jerusalem artichoke in irrigated agriculture, repeated irrigation is carried out along the furrows. Therefore, the soil under the bottom of the irrigation furrow is more moistened and also retains moisture longer. Therefore, the tuberous roots of Jerusalem artichoke develop under the bottom of the furrow, and tubers appear there at a depth of 8.0 cm from the bottom. Therefore, when harvesting in such fields with the help of ordinary potato diggers, the plowshares of which are not adapted to sink deeper than the bottom of the irrigation furrows, a part of the grown crop is left on the field (up to 15-18%)

For more complete harvesting of the grown Jerusalem artichoke crop in irrigated agriculture, it is also necessary to process the soil under the bottom of the furrow to extract all the tubers from there.

Plowshares, adapted to extract tubers from under the irrigation furrow, turn out to be cumbersome, energy-intensive, therefore, they should be made of lattice from longitudinal grates, when part of the soil will be separated already on the plowshare, facilitating the work of the elevator conveyor.

References

- [1] Panchev I, Delchev N, Kovacheva D, and Slavov A 2011 *Eur. Food Res. Technol* 889–896.
- [2] Praznik W, Cieřlik E, and Filipiak-Florkiewicz A 2002 *Nahrung/Food*, 151
- [3] Yang L, Q. S. He, Corcadden K, and. Udenigwe C. C 2015 *Biotechnology Reports* 77–88
- [4] Szewczyk A 2019 *Annals of Agricultural and Environmental Medicine* 24–28
- [5] Tesio F, Weston L. A, Vidotto F, and Ferrero A 2010 *Weed Technol*, 378–385
- [6] Heirloom Jerusalem Artichoke Varieties | MOTHER EARTH NEWS'. Available at: <https://www.motherearthnews.com/organic-gardening/heirloom-jerusalem-artichoke-varieties-zewz1308zpit>
- [7] Baldini M, Danuso F, Rocca A, Bulfoni E, Monti A, and. Mastro G 2011 *Ital. J. Agron.* 126–132
- [8] Ibarguren L, Rebora C, Alberto M, 2018 Harvest time effect on horticultural quality of topinambur (*Helianthus tuberosus* L.) kept in the soil or in cold storage *Revista de la Facultad de Ciencias Agrarias* **50** 61-71
- [9] Latza R, and Lehmann G 1998 *Aktuel. Ernährungsmed.* 33–37,
- [10] Stolzenburg K 2005 *Zuckerindustrie*, 193–200
- [11] Slimestad R, Seljaasen R, Meijer K, and. Skar S. L 2010 *J. Sci. Food Agric.* 956–964
- [12] Naumova N, Shtevyeva K, Burmistrova O. and Burmistrov E 2020 *Bulg. J. Agric. Sci.* 701–707
- [13] Schorr-Galindo S, and Guiraud J. P 1997 *Bioresour. Technol.* 15–20

- [14] Starovoytov V, Starovoytova O, Aldoshin N, and Manohina A 2017 *Acta Technol. Agric.* 7–10
- [15] Turaev S M, 2014 *prepare biogumus and plant it on a peasant farm the effect of dressing (on the example of Topinambur, Mahsar)*
- [16] Rossini F, Provenzano M E, Kuzmanović L, and Ruggeri R 2019 *Agronomy.* 528
- [17] Goryachkin V P 1968 *collected works.* Moscow,.
- [18] Kolchin N N, 1982 *Complexes of machines and equipment for post-harvest processing of potatoes and vegetables.* Moscow, 268.
- [19] Lubovskny N P 1951 *Agrotechnics and selection of ground pear (jerusalem artichoke) in the Donbass*
- [20] Martinova N, Shavazov K, Telovov N, Toigambayev S, and Yusupov S 2020 *IOP Conf. Ser. Earth Environ. Sci.* **614** 012145
- [21] Shoumarova M, Abdillaev T 2019 *Agricultural machines* 112