

PAPER • OPEN ACCESS

## Bench tests of the friction drive of the vertical spindle made of poly-V belts for improving cotton harvesters

To cite this article: M Shoumarova *et al* 2022 *IOP Conf. Ser.: Earth Environ. Sci.* **1076** 012007

View the [article online](#) for updates and enhancements.

You may also like

- [Spectral and temporal characterization of sleep spindles—methodological implications](#)

Javier Gomez-Pilar, Gonzalo C Gutiérrez-Tobal, Jesús Poza et al.

- [Electrification of the mechanical drive of vertical spindle cotton picker drums](#)

M Shoumarova, T Abdillayev and Sh A Yusupov

- [Parameters of the stabilizer of the poly-V belts of the drive of vertical spindles for stable cotton harvesting performance](#)

M Shoumarova, T Abdillayev and Sh A Yusupov



245th ECS Meeting • May 26-30, 2024 • San Francisco, CA

[Learn more & submit!](#)

Present your work at the leading electrochemistry & solid-state science conference.

Network with academic, government, and industry influencers!

Submit abstracts by December 1, 2023



# Bench tests of the friction drive of the vertical spindle made of poly-V belts for improving cotton harvesters

M Shoumarova, T Abdillayev and Sh A Yusupov

Tashkent Institute of Irrigation and Agricultural Mechanization Engineers (National Research University), Tashkent, Uzbekistan

E-mail: sher\_xxx89@mail.ru, sherzod-yusupov@tiame.uz

**Abstract.** The article reports that in order to improve the functional characteristics of the friction drive of vertical spindles, it was proposed to replace its conventional V-belts with poly-V-belts. Therefore, rollers with changed parameters are installed on the spindles, while maintaining the magnitude of the rolling radius of serial rollers. To determine the functionality of the new drive, a stand with a single spindle drum was created, which allows you to determine all the performance indicators of the polyline drive. The main task of research on this stand was to determine the possibility of creating a traction (friction) force of the drive that always exceeds the resistance force of a cotton bush clamped in a narrow working slot of the harvesting apparatus. To assess the functionality of a new version of the friction drive, a comparison technique was used when at the beginning the friction (thrust) force of a serial roller with a V-belt drive was measured, and then, on the stand-pull force of the drive with a poly-V-belt. A special device was made to measure the pulling force of the belts.

## 1. Introduction

It is known that the completeness of the cotton harvest of a vertical-spindle machine is inferior to that of a horizontal-spindle machine. There are many reasons, however, in our opinion, the main reason is the shortcomings of the friction drive of the vertical spindle compared to the “hard” drive of the horizontal spindle. In the working chamber of the harvesting machine, the spindle must capture the fibers, remove them from the sash of the box and wind to melt on ourselves. To do this, first of all, the spindle tooth must have an absolute speed of sufficient speed and, most importantly, directed within limited boundaries [1]. The direction of the absolute speed of the tooth depends on the vector sum of the working speed of the machine moving  $\vec{V}_M$  through the field, on the circumferential velocity of  $\vec{V}_D$  the drum in the centers of the spindles, as well as the circumferential velocity of the spindle itself  $\vec{V}_S$ . The speed  $\vec{V}_M$  of the machine in the field is constant, and  $\vec{V}_D$  the size is also constant, but changes direction depending on the location of the spindle on the drum. The circumferential velocity  $\vec{V}_S$  of the tooth relative to the axis of rotation of the spindle is also constant in magnitude, but changes direction when the place of the tooth changes [2-3].

The value of the angular speed of the spindle mainly depends on the quality of its belt drive. Very often, due to fatigue of the springs that stretch the belts of the drive, the tension of individual belts is weakened, which reduces the pressure of the belts on the rollers, hence the friction force of the roller with the belts. Therefore, with a large resistance of the bush, cotton the angular velocity of the spindle decreases, which reduces  $\vec{V}_S$ . Geometric with the ummah of velocities  $\vec{V}_M$ ,  $\vec{V}_D$ , and  $\vec{V}_S$ , i.e. the absolute



speed of the  $\bar{V}_A$  tooth constantly changes its size and direction. The spindle tooth works as a dihedral wedge, so it can be embedded into the interfibre space of cotton if the direction  $\bar{V}_A$  is close to the bisector of the angle of the tooth in a small angle of angle  $\beta$  [4], [5]. Often  $\bar{V}_A$  it is directed outside the corner  $\beta$ . In such situations, the tooth cannot penetrate into the cotton. In addition, the tooth can trap the fibers of the cotton clod, if it is embedded in it deep enough to capture a sufficient number of fibers. Therefore, the value  $\bar{V}_A$  also affects the cotton harvest. It follows from the foregoing that the main reason for the decrease in the completeness of the collection should be considered a violation of the normal functioning of the spindle drive [6]–[8].

Figure 1 shows the scheme of friction drive of vertical spindles. The rotating drum 1 carries the spindles 2 first to the working area of the harvester, where the cotton bush is strongly clamped. The rollers of the spindles, rolling over the external fixed V-belts 3, receive rotational motion with an angular velocity  $\omega_r$ , the value of which predetermines the nature of  $\bar{V}_A$ . To ensure the required direction  $\bar{V}_A$ , it is necessary to provide the calculated  $\omega_r$ , for which it is necessary to press the rollers against the belts with sufficient pressure, which depends on the belt tension force created by the springs 4.

Our research has shown that the manufacturer does not sufficiently control the quality of the installation of the friction drive -the tension of the belts is insufficient and uneven, which is why the friction force of the roller with the belts, i.e. the traction force of the drive is insufficient and unstable. Therefore, with an increase in the resistance forces of the cotton bush, the spindle slows down its rotation, the cotton harvest deteriorates sharply.

Therefore, in order to ensure the required traction force of the drive, we proposed to replace conventional V-belts with poly-V-belts, which knead one common traction base. They are more flexible, so they wrap around the rollers with a large angle. All this increases the traction ability of the drive. Naturally, the replacement of the belts required a change in the design of the rollers, to provide a device that ensures that the rollers hit the beginning of the belts at the minimum angular velocity of the spindle when it was reversed.

## 2. Research methods in the working area of the device

A stand with one spindle drum was made (figure 2). With its help, the functionality of the improved friction drive was evaluated. The main, main task was to determine the pulling capacity of the drive, because it was assumed that the drive, first of all, must constantly provide sufficient tractive force, and secondly, the necessary angular speed of the spindle in the working area. This article highlights the results of the assessment of the traction method of the recommended drive.

The serial drive of the spindles of the vertical-spindle cotton harvester consists of ordinary V-belts (figure 1). In the working area of the apparatus, the fixed belts cover the spindle rollers from the outside, so they rotate in the direction of the teeth to capture and extract cotton from the flaps of the cotton bush. The rotating drum carries the spindle with wound cotton to the removal area where fixed straps cover the rollers from the inside, causing the spindles to reverse, rotate against the direction of the teeth, which facilitates the removal of cotton wound on them.

The angular velocity of the spindle in the working area should provide the best direction of the absolute speed of the tooth, when, it can penetrate into the space between the fibers in the flap of the box to capture them and remove them from the leaf.

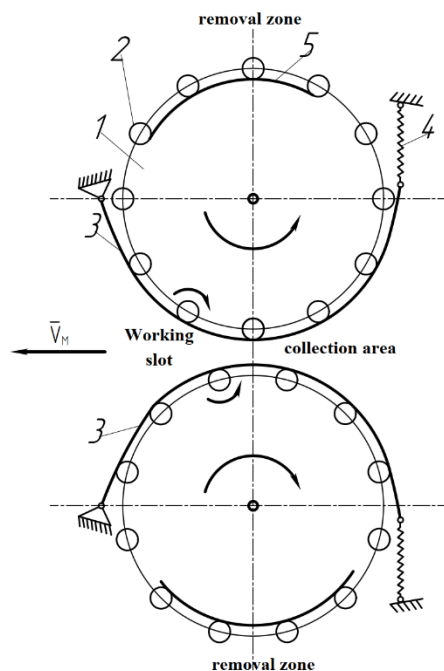

**Figure 1.** Scheme of the spindle drive mechanism: 1- spindle drum; 2-spindles; 3- external wedge belts in the assembly area; 4- tension spring; 5- internal belts in the area of cotton removal from the spindles.

The working slit between the adjacent drums of one row is installed no more than 36 mm, which is why the bushes here are crimped tightly with a spindle. Therefore, the resistance  $R_k$  of the bush to the rotation of the spindle increases. If the traction force  $T$  of the belts is less than some threshold, the angular velocity of the spindle decreases, the direction of the absolute speed of the tooth changes, which is why the spindle tooth will not be able to capture the fibers, it will be impossible to collect cotton. To ensure  $T > R_k$  that 3 belts are installed on the serial drive, so that the sum of their friction forces with the rollers and ensured the required disparity of power. The frictional force depends on the pressure of the belt on the roller, which in turn depends on its tension. The tension of each belt is provided by a separate spring of tension 4 (figure 1), Often the characteristics of these springs change over time, the belts are pressed against the roller differently, the sum of their friction forces with the rollers is often less than the value the resistance force of the spindle bush is why the cotton harvest is sharply reduced.

In order to improve the functioning of this friction drive, we proposed to replace conventional V-belts with poly-V-belts.

Poly-V belts have one common traction base, so its wedges will be pressed against the roller with the same pressure. They are more flexible, so it is allowed to use them to rotate pulleys of small diameters, such as spindle rollers.

Naturally, for the use of multi-ribbed belts, the design of the spindle roller was changed, and an additional stabilizer was installed, which slows down the spindle roller before it is reversed on the external and internal belts, so that the roller runs into small belt wedges at a minimum speed, which will facilitate the orientation of the roller edges along the belt wedges.

For laboratory studies of the kinematic and dynamic indicators of this drive, a stand with one spindle drum was manufactured (figure 2). This design facilitates the inspection, adjustment and control of all elements of the stand.



**Figure 2.** General view of the laboratory stand: 1-frame; 2-spindle drum; 3-spindle; 4-prototype roller; 5-poly-V belt; 6-electric motor.

Spindles with rollers are installed on the drum of the stand, the design of which is adapted for rolling along the profile of poly-V-belts (figure 3).

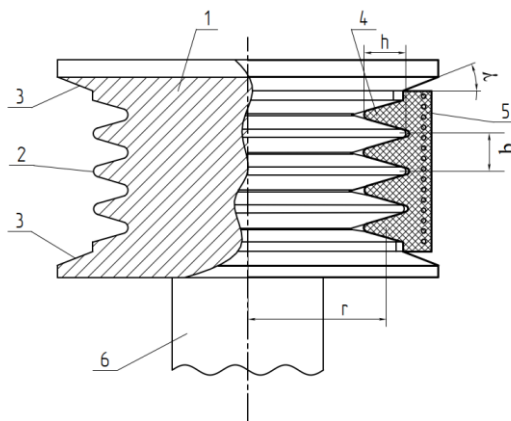

**Figure 3.** Design of rollers for rolling over poly-V-belts: 1-coil skeleton; 2-faces; 3-reborde; 4-wedge belt; 5-base belt; 6-shank.

Figure 4 shows a diagram of attaching the poly-V-belt to the hooks, which, like the existing method, easily hook to the drum frame.



**Figure 4.** Fastening of metal hooks to the poly-V-belt.

Figure 5 shows the scheme of fastening the springs of stretching the poly-V-belt. To maintain the stability of the belt in the vertical plane, two springs from the serial apparatus are installed. The plate for attaching the springs to the frame is also attached by means of 2 screws that allow you to change the tension of the belt to the desired value. The working length of the belt is the same as on the serial device.



**Figure 5.** Scheme of fastening springs to the poly-wedge belt.

At the beginning of the experiments on the drums of the serial apparatus, the tension force of all V-belts separately on all drive sets was measured using a dynamometer. To do this, the working length of each spring stretching the belts separately was measured. Then the springs were removed and stretched to this working length by a dynamometer. The dynamometer reading was taken as the tension force of the belt in the working position. On the serial apparatus, the friction force was also measured. A standard spindle roller with a set of V-belts. For this purpose, a simple device was made (figure 6). As already noted, rotating the drum manually, the spindle is brought to the narrowest part of the working area of the apparatus, then the free end of the shell and 2 spindles are raised and lever 5 is attached to the released rod with a clamp 3. E allows you to open the lower end of the spindle rod, where the lever 5 is then converted.

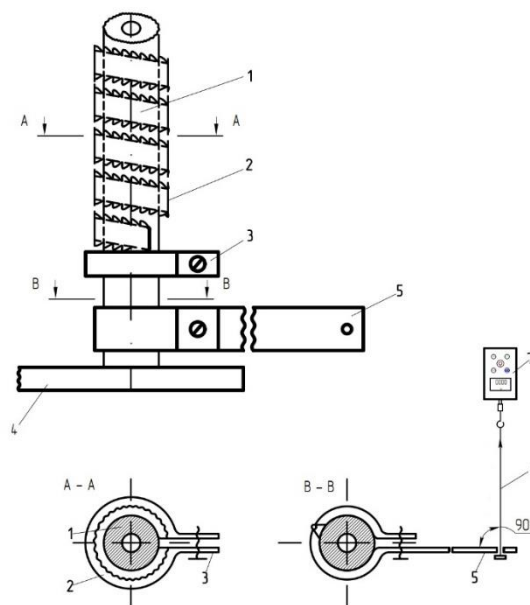

**Figure 6.** Scheme of the device for measuring the friction force of the spindle roller with a set of V-belts: 1- compound spindle; 2- sheath spindle; 3 – a clamp that serves as a support for the raised spindle shell; 4- the lower disc of drum; 5- rychag; 6- cable to the dynamometer; 7- dynamometer;

To the outer end of the lever is attached a non-stretchable cable 6 with a dynamometer 7. The cable with the dynamometer is pulled in the direction when the tensioned cable is perpendicular to the lever. Pulling the cable without jerks, fix the dynamometer readings at the time the spindle begins to turn. Then, turning the drum, the other spindles are brought to the same position and the  $\bar{P}_r$  rest friction force of the belt rollers is measured. The arithmetic mean value  $\bar{P}_r$  is calculated, as well as their squared average deviation. These measurements are taken in the same position. were found on a serial cotton harvester, with a serial friction drive of spindles.

The poly-V-belt should provide the same resting friction force  $\bar{P}_r$  of serial rollers. On a bench with a poly-V-belt, the  $m$  is measured  $\bar{P}_r$  for varying degrees of tension. The tension when  $\bar{P}_r$  a force equal to that obtained on serial V-belts is provided is taken as the optimal tension of the poly-V-belts.

Thus, the tension force of the V-ribbed belt is found when the same friction force of the rollers with the belts is provided as on serial belts. This will suggest that the cotton-picking conditions will be maintained as with a serial drive.

Laboratory studies have shown that in order to create a serial force,  $P_r$  poly-V belts should be pulled with less force than serial belts, which is a positive result. With a small tension force of the belt, the pressure on the upper bearing of the spindle will decrease. This result suggests that, firstly, the service life of the upper bearings will increase, and secondly, the power consumption when the drum rotates will also decrease. Drops. To test this assumption, the amperage consumed by the electric motor on the stand (figure 2) during rotation and the experimental spindle drum were measured, as well as the strength of the current during rotation and one drum with a serial friction drive. And the poly-V-actuator consumed by 18-20% less. Of course, in the future, more detailed studies of power consumption on poly-V belts will be carried out.

### 3. Research methodology for the removal zone of the device

It is known that the spindle enters the removal zone with cotton wound on itself. To facilitate the removal of cotton from the spindle, it is necessary to reverse it so that it rotates to the back side of the tooth. Therefore, the drive belts here are installed from inside the rollers. At the beginning of the roller collision with the inner belt, it rotates by inertia in the direction of tooth sharpening, although it is braked to change the direction of rotation. During braking, negative angular accelerations occur, which generate large forces of inertia. Therefore, the wound cotton will begin to unwind and part of it will be removed by the spindle in the form of a "self-reset". If the acceleration is excessively large, the coil may lose contact with the tooth, causing the coil to appear in the form of a freely planted ring. It is known that the brush puller cannot remove all the cotton from the spindle, so such a cotton ring in the form of a "self-assembly" will be carried away to the working area. The amount of cotton entering the hopper will be less than what was collected by the spindles. If the acceleration is less than the optimal value, the self-discharge will decrease, there will be a lot of cotton on the spindle, it will be difficult and it will be difficult to remove cotton with a brushed puller.

The purpose of our research is not a deep analysis of the process of self-reset on poly-V-belts, because this will require "subtle" instrumental studies. Therefore, we decided to keep the braking path of the spindle on the poly-V-belts the same as on the serial drive with v-belt belts. To do this, we visually determined the length of the internal belts, subjected to increased wear on cotton harvesting machines, having worked  $x$  the cleaning season on the field. Of course, the accuracy of the results will not be very high, but acceptable in our opinion. Studying the wear of internal belts in economic conditions, we came to the conclusion that the initial part of the internal belts with a length of 35-40 mm wears out, which corresponds to the angle of rotation of  $\gamma = 0.25 - 0.30 \text{ rad}$  the drum, or  $\gamma \approx 14 - 17^\circ$  (at angular velocity baraban  $\omega = 11.0 \text{ rad/sec}$ ). Taking into account that the rolling radius of the new roller is preserved as in serial rollers, as well as the angular speed of the spindle in the working area is preserved as on serial belts, it was decided to keep the pressure of the internals of its poly-V-belt on the rollers as on serial belts, i.e. the spring pressing the pad with the belt to the rollers should remain unchanged.

Therefore, at the beginning of the research, the traction force of the internal belts of the serial drive was determined using the same device as for the working area of the device. Then I measured the pulling force of the reverse rotation pad multi-V belt. As a result of these forces, it is assumed that the function of the new drive will ensure the normal course of the process of removing cotton from the spindles. Thus, the manufactured stand with one spindle drum allows you to fully explore the new drive with multi-V-belts in full.

#### 4. Research results

To evaluate the multi-V drive of the spindles, first of all, it was necessary to determine whether it is provided and whether it is the required traction force of the drive. The value of the pull force of the poly-V belt is the main argument for its suitability in the first case, and not the magnitude of the angular velocity of the spindle. Because by changing the rolling radius of the roller along the belts, it is possible to achieve the necessary angular velocity of the spindle in the working area of the device.

We believe that a workable serial drive as a whole must create the traction force required to overcome the resistance forces of the elements of the cotton bush. We believe that vertical-spindle cotton harvesters in vast fields of farms work satisfactorily, therefore, the traction force of the serial drive is generally sufficient to ensure the technological process of the apparatus. On this basis, we took the traction force of the serial drive with V-belts as standard, which poly-V belts should also provide.

On a workable harvester, the pulling force of  $T_s$  the serial V-belts was measured in static on all 12 rollers of the spindles, one drum as close as possible to the bush of cotton, crimped in the working area of the apparatus. To do, manually rotating the drum, the spindle was brought to the position most embedded in the bush. The position of the spindle is taken as the maximum introduced into the cotton bush when the next spindle rotates the drum to the place closest to the opposite drum. It is known that to facilitate service work, the external drums open on  $40^\circ$  relatively internal ones. When measuring and  $T_s$  using the call, it is possible to facilitate access to the objects of measurement.  $T_s$  measurements were carried out using a device with a dynamometer, described in the research methodology section. Availability for measurements  $T_s$  between the front pair of drums favorable, so they measured only 24 (12 on the left and right drums) spindles keeping the serial belts in their place. Arithmetic mean value  $T_s = 43.85 \text{ N}$ , standard deviation  $\sigma = 5.5 \text{ N}$ , and coefficient of variation  $K_V = 12.6 \%$

Then, the pulling force of the poly-V belts on the stand was studied. First of all, the tension of the two cylindrical springs was selected so that the tension of the poly-V-belt was the same force as on the serial belts. On the stand, it is possible to change the tension forces of the belt springs. Therefore, by installing a poly-V-belt belt of the same size, which corresponds to the tension of serial belts tension  $P_p$  With the resulting force,  $P_p$  the pulling force of the poly-V belt on the spindle roller in  $T_p$  its maximum embedded and in the working area was measured.

There are only 12 spindles on a single drum stand. Therefore, for one tension of the springs,  $T_{p1} \dots T_{p12}$  were measured in turn and the arithmetic mean  $\bar{T}_{pam}$  and the standard deviation  $\sigma$  were calculated. The sum of the tension forces of the three springs on the serial drive was 131.4 N, and the sum of the tension of the two springs on the poly-V-belt was 129.2 N.

By installing the spindle in the same position as in previous experiments, the pulling force of the belt on its roller was measured. Spindle and alternately installed as in figure 7. under No. 1, 2, 3, 4, 5. The measurements results are given in table 1. In the position No. 3 (figure 7) it was considered that one hundred spindles were maximally embedded in the bush.

**Table 1.** Change in the traction force of the belts on the rollers of the spindles located on the outer belts, N.

№	Conventional spindle numbers, on serial external belts					Conditional spindle numbers, on external poly-V-belts				
	1	2	3	4	5	1	2	3	4	5
1	31.86	51.92	38.94	37.76	35.4	54.28	83.78	75.52	66.08	63.72
2	41.3	46.02	38.94	37.76	36.58	73.16	82.6	80.24	76.7	68.44
3	51.92	60.18	53.1	48.38	35.4	71.98	84.96	82.6	69.62	63.72
4	51.92	57.82	50.74	38.94	35.4	73.16	90.86	81.42	76.7	63.72
5	54.28	41.3	49.56	42.48	37.76	64.9	93.22	87.32	80.24	68.44
6	43.66	50.74	42.48	47.2	36.58	66.08	86.14	76.7	74.34	73.16
7	33.04	42.48	41.3	34.22	33.04	53.1	84.96	82.6	73.16	70.8
8	31.86	50.74	38.94	35.4	31.86	55.46	79.06	68.44	67.26	60.18



9	46.02	44.84	41.3	37.76	31.86	70.8	102.66	97.94	92.04	73.16
10	38.94	55.46	37.76	35.4	29.5	48.38	82.6	80.24	67.26	60.18
11	54.28	51.92	50.74	30.68	38.94	46.02	70.8	75.52	74.34	67.26
12	41.3	51.92	42.48	41.3	41.3	53.1	80.24	67.26	67.26	71.98
$M_a$	43.36	50.44	43.85	38.94	35.30	60.86	85.156	79.65	73.75	67.063
$\sigma$	8.481	5.870	5.553	5.180	3.316	10.16	7.9050	8.1830	7.3690	4.7155
$V$	19.55	11.63	12.66	13.30	9.395	16.70	9.2829	10.273	9.9919	7.0314

For the clarity of the comparison of the traction forces of serial V-belts and poly-V-belts, a diagram of the traction forces is constructed, which are shown in figure 7. It turned out that the maximum value  $T_p$  of the traction force is observed in place of the spindle N2, although the belt tension on roller N1 is greater than on N2. But apparently the geometric pa the position of the roller N1 gives less belt pressure than on the roller 2. Further, the pulling force on rollers N3,4 and 5 decreases, which corresponds to a decrease in the tension of the belt sections between the rollers 2-3, 3-4, 4-5. But this situation does not affect the cotton harvest, because in position N1 the spindle does not meet and does not contact the bush. In general, the pulling force of the polyline a belt with 5-10 wedges throughout is always greater than the same indicator of a serial drive, which is the same as.

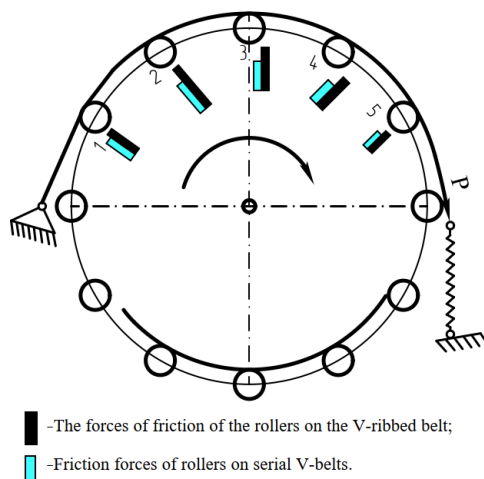

**Figure 7.** Comparative diagram of the friction forces of spindle rollers for serial and poly-V-belts.

The pulling force of a poly-V belt mounted on a pad of rotation was evaluated. In general, the drive of the spindles from the poly-V belt for the area with cotton from the spindles is recognized as workable.

## 5. Conclusions

The experience of long-term economic operation of vertical-spindle cotton pickers shows that the value of the thrust of the friction drive belts of vertical spindles is sufficient to ensure satisfactory completeness of cotton picking, however, it is not stable enough. Often, the friction force of the spindle roller on the fixed three V-belts is less than the resistance of the bush, which is why the required angular speed of the spindle is not provided, and the completeness of the collection worsens.

If the serial drive belts of the spindles are replaced with poly-V-belts, of course, by changing the geometric parameters of the roller, an increase in the traction force of the drive is noted relative to the performance of the serial drive.

Replacing conventional V-belts with poly-V belts in the friction drive on spindles reduces the power consumption of one drum by 18-20%.

Experiments on the bench showed that even when installing five wedges, i.e. small V-ribbed belt at the same tension with serial belts, an increase in traction force by 30% or more along the entire length of the outer belts is provided. This result indicates that the stability of the angular velocity of the spindle under load in the working area of the harvester will be ensured. This will certainly lead to the stability of the completeness of the cotton harvest by vertical-spindle machines.

## References

- [1] Yusupov S A, Shoumarova M and Abdillaev T 2021 *Tech. Sci.* **4(1)** 42–9 doi: <http://dx.doi.org/10.26739/2181-9696-2021-1-7>
- [2] Sablikov M V 1985 *Cotton picking machines* (Moscow: Agropromizdat)
- [3] Shaumarova M, Abdillayev T, Sarimsakov B and Yusupov S 2020 *IOP Conference Series: Materials Science and Engineering* **883** 012099 doi: 10.1088/1757-899X/883/1/012099.
- [4] Shoumarova M, Abdillayev T and Yusupov S 2021 *IOP Conf. Ser. Earth Environ. Sci.* **868** 012043 doi: 10.1088/1755-1315/868/1/012043
- [5] Lazunov V I 1965 *Mech. Cott. growing* **1** 6–11
- [6] Rizaev A A 2017 *Research and creation of working bodies of a cotton picker with high efficiency* (Tashkent: Publishing house “FAN” AS Ruz) <http://isbn.natlib.uz/uz-Latn-UZ/Search/Search?page=958&size=10&type=9>
- [7] Rizaev A, Yuldashev A, Kuldoshev D, Abdillaev T and Ashurov N 2020 *IOP Conference Series: Materials Science and Engineering* **883** 012157 doi: 10.1088/1757-899X/883/1/012157
- [8] Turanov K, Abdazimov A, Shaumarova M and Siddikov S 2021 *Advances in Intelligent Systems and Computing* **1258** 290-305 doi: 10.1007/978-3-030-57450-5\_27