

PAPER • OPEN ACCESS

## Results of extensive tests of a hanging brush grade equipped with track softeners and field soft devices

To cite this article: A Tukhtakuziev *et al* 2023 *IOP Conf. Ser.: Earth Environ. Sci.* **1284** 012027

View the [article online](#) for updates and enhancements.

You may also like

- [Evaluation Method Of Important Nodes Of Water Supply Network Under Terrorist Attack](#)  
Chen Shun, Zhao Xudong, Xiao Baoqiang et al.
- [Transportation organization design of Tangshan West Comprehensive Passenger Terminal](#)  
Jingcheng Sun
- [Applicability analysis of different evaluation methods in groundwater quality evaluation: A case of Xi'an city](#)  
Siqi Li, Xiaoxin Shi, Hui Qian et al.

**PRIME**  
PACIFIC RIM MEETING  
ON ELECTROCHEMICAL  
AND SOLID STATE SCIENCE

HONOLULU, HI  
Oct 6-11, 2024

Abstract submission deadline:  
**April 12, 2024**

Learn more and submit!

**Joint Meeting of**  
The Electrochemical Society  
•  
The Electrochemical Society of Japan  
•  
Korea Electrochemical Society

# Results of extensive tests of a hanging brush grade equipped with track softeners and field soft devices

A Tukhtakuziev<sup>1</sup>, A R Rasuljonov<sup>1</sup>, Sh N Barlibaev<sup>2</sup> and Sh Kimsanov<sup>2</sup>

<sup>1</sup>Scientific-Research Institute of Agricultural Mechanization, Samarkand str. 41, Yangiyul dis., Tashkent reg., Uzbekistan

<sup>2</sup>Tashkent Institute of Irrigation and Agricultural Mechanization Engineers, National Research University, K.Niyazi str. 39, Tashkent, Uzbekistan

\*E-mail: abduraxmon\_qxmei@mail.ru

**Abstract.** The article presents the structure, technological work process, values of basic parameters, technical description, and results of field tests of a comprehensive suspended screed-leveler equipped with devices that can quickly and easily adjust the pressure on the soil and create a soft soil layer on the surface of the field. According to the results of the tests, the working depth of the trail softener was 19.6 cm and 19.3 cm. At speeds of 6-8 km/h, the performance of a comprehensive roller-leveler equipped with track softeners and a device that creates a soft soil layer on the surface of the field is 4.96-6.24 ha/h in the main time, the performance in the operational time is 3, 77-4.74 ha/h, fuel consumption was 4.0-4.4 kg/ha. These remarks confirm that the pilot copy of the comprehensive roller-leveler, equipped with track softeners and a device that creates a soft soil layer on the field surface, performed the specified technological process reliably and qualitatively, and its performance fully corresponds to the initial requirements.

## 1. Introduction

Transition to intensive methods in agricultural production due to the introduction of modern agrotechnologies and provision of agroclusters and farms with high-performance agricultural techniques is the most important direction in the sustainable and effective development of this sector [1-4].

The main task in preparing the land for planting is leveling the surface of the fields, compacting them to the required level and crushing the large lumps in it, creating a soft soil layer. Currently, in Uzbekistan MV-6.0, MV-6.5 and other trowels available on farms are widely used. It is usually required to pass them two or three times in one place to treat the land at the required level which demands increased labor and economic costs [5-11].

Based on the above, we have developed and tested a comprehensive suspension leveler (hereinafter referred to as a leveler) equipped with devices that quickly and easily adjust the pressure on the soil and with track softeners and devices that create a soft soil layer on the field surface. Fig. 1 shows central and right and left side sections. The side sections are connected to the central section through longitudinal hinges and are moved from the working position to the transport position and from the transport position to the working position by means of hydraulic cylinders.



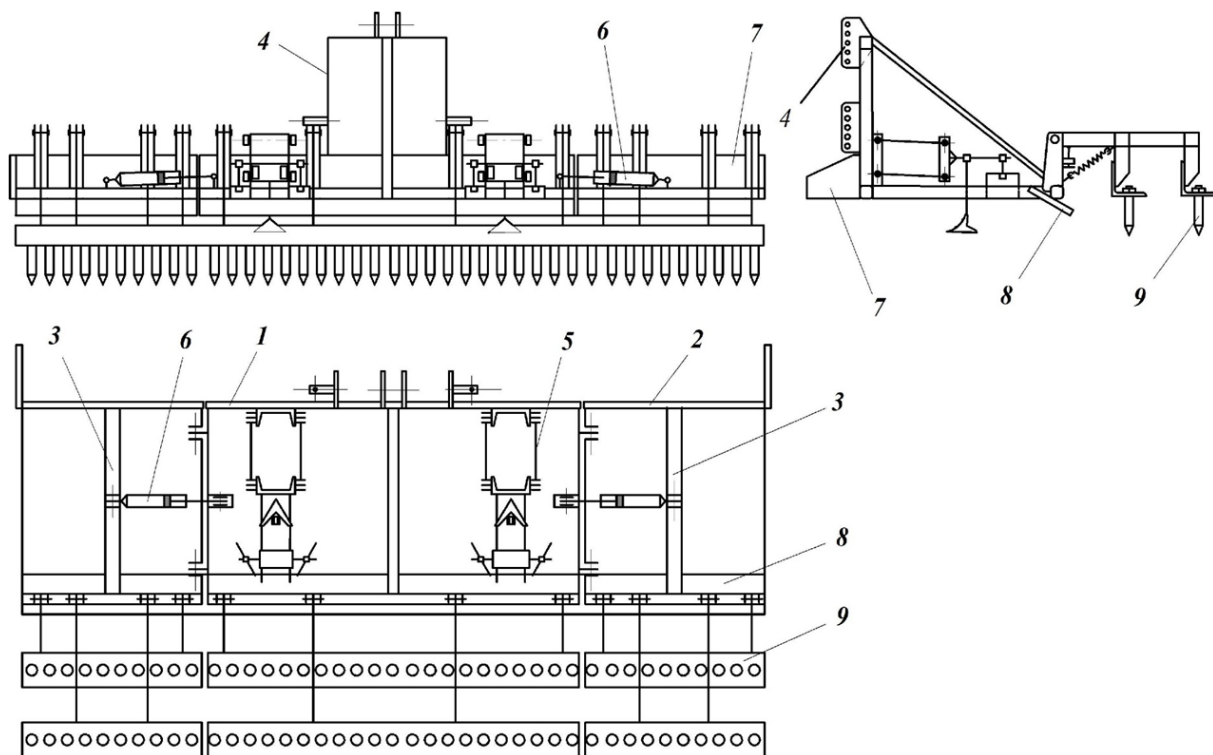

**Figure 1.** Constructive scheme of a grinding wheel-leveler equipped with track softeners and a device: 1-central section; 2-right side section; 3-left side section; 4-suspension device; 5-trace softener; 6-hydraulic cylinder; 7-straightener; 8-compressor; 9-device that creates a soft soil layer on the surface of the field

Every section of the mola-leveler consists of transverse and longitudinal brushes that connect them to each other, and a device that forms a soft soil layer on the surface of the field (hereinafter referred to as the device). equipped with parts.

The central section is additionally equipped with a suspension device and working bodies that soften and level the traces formed by the tractor wheels, that is, trace softeners.

The trail softener consists of flat cutting claws and straighteners that have been sharpened from the right and left blades. The device is made of longitudinal hammers, transverse planks attached to them through beams, two rows of teeth attached to the planks in a checkerboard pattern, and springs that act on stretching, which serve to adjust the depth of the teeth into the soil.

The central and side sections of the leveler are fixedly connected to each other during operation and form a single rigid system. For this, special fixing fingers are installed in the central and side sections.

To ensure quick and easy adjustment of the trowel-leveler's pressure on the soil, it is considered to change the vertical distances from its support plane to the lower suspension points and between the lower and upper suspension points. For this purpose, five holes are opened in the brackets of the grinding device (Fig. 1).

When grinding light soil conditions and shallow chiselled (10-12 cm) lands, the longitudinal pulls of the tractor suspension mechanism rub into the low holes opened in the brackets of the leveler suspension device, in medium and deep chiselled (16-20 cm) soil conditions - to middle holes, in heavy soil conditions and in cultivated lands - it is installed in the upper holes.

## 2. Methods and materials

During the working process of the trowel-leveler, its leveler smoothes unevenness on the field surface by cutting the ridges and pushing them to the depressions, and the compactor compacts this leveled

surface at the required level. Track softeners soften and level the tracks made by tractor wheels, the teeth of the device are leveled and compacted, and on the surface of the field, they create a layer of soft soil 4-5 cm thick, which ensures long-term preservation of soil moisture.

Tables 1 show the determined parameters of the gravel leveler and compactor as well as the trail softeners and devices installed as a result of the research.

**Table 1.** Parameters of the brush leveler and compactor, as well as the installed track softeners and accessories

№	The name of the parameters	Unit of measure	Value
<b>1</b>	<b>2</b>	<b>3</b>	<b>4</b>
<b>1 Mola-leveler parameters of the compressor</b>			
1.1	Leveler height	cm	40
1.2	The length of the working surface of the compressor	cm	30-32
1.3	The angle of installation of the compressor relative to the horizon	°	29-32
1.4	Vertical distance between the leveler and the compactor, cm	cm	3-4
1.5	Longitudinal distance between the leveler and the compactor	cm	150
1.6	The only load given to the compressor	kN/m	2.4-2.8
1.7	The vertical distance from the reference plane of the shaft to the lower growth points	cm	60-70
<b>2 Parameters of softeners</b>			
2.1	The angle of entry (rubbing) of the flat cutter blade into the soil	°	24-31
2.2	The width of the flat cutter claw	cm	7
2.3	Grinding angle of flat cutting claw blades	°	24-31
2.4	The angle of installation of the blades of the flat cutting claw relative to the direction of movement	°	30.0-33.0
2.5	Opening angle of flat cutting claw blades	°	60-65
2.6	Coverage width of the flat cutting claw	cm	40
2.7	The depth of immersion of the flat cutter claw into the soil	cm	20
2.8	The angle of installation of the straightener relative to the direction of movement	°	30
2.9	The opening angle of the straighteners	°	60
2.10	The coverage width of the levelers, at least	cm	70
2.11	The gap between the aligners, at most	cm	22
2.12	The length of the straightener, at least	cm	40
2.13	The vertical distance from the parallelogram mechanism rod to the lower edge of the leveler	cm	40
<b>3 Parameters of the device that creates a layer of soft soil on the surface of the field</b>			
3.1	The diameter of the tooth	mm	14
3.2	Tooth length	mm	100-125
3.3	The length of the lower sharpened part of the tooth	mm	9.6-11.8
3.4	Vertical loading per tooth	N	11.6-13.6
<b>1</b>	<b>2</b>	<b>3</b>	<b>4</b>
3.5	The width of the gear tooth tracks, max	mm	48

3.6	Transverse distance between teeth mounted on one plank, max	mm	96
3.7	The longitudinal distance between the front teeth of the device and the compactor of the grindstone is at least	cm	18
3.8	The longitudinal distance between the gear teeth is at least	cm	19.4
3.9	The tension force of the spring	N	314

Figures 2 and 3 show the general and operational views of the pilot grinder-leveler, and its technical description is presented in Table 2.

Tests of the experimental version of the leveler were conducted in the fields of the institute's experimental farm during the period of land preparation for sowing seeds.

In the tests, the leveler was used in addition to the New Holland T7060 tractor. In this case, the working speed was set at 6 and 8 km/h, and the trail softeners were installed at a depth of 18-20 cm.

In the tests, the following performance indicators of the grinder-leveler were determined:

- soil quality;
- processing depth of track softeners;
- density of the soil in a layer of 5-15 cm;
- mean square deviation of heights of irregularities on the field surface;
- prime time productivity;
- fuel consumption.

Soil quality, tillage depth, soil quality.

The density in the 5-15 cm layer, the mean square deviation of the heights of irregularities on the field surface UzDSt 3412:2019 "Testing of agricultural equipment. Machines and tools for soil surface treatment. Test program and methods" [12] was determined by the normative document.

**Table 2.** Technical description of the test copy of the grinding machine equipped with track softeners and devices

Name of indicators	Unit of measurement of indicators	The value of indicators
Type	–	suspension
The class of tractors used in addition	–	3-4
Work speed	km/h	6-8
Width of coverage	m	8
Mass	kg	1620
Prime time productivity	ha/h	4.8-6.4
External dimensions:	mm	
- width		8000
- length		1680
- height		1450

Chronometric observations were made to determine the efficiency and fuel consumption of the leveler, and the coefficients of the cultivated area and fuel consumption, shift and operational time were determined per unit of operational time.

Soil moisture, hardness and density were studied before the tests [13, 14]. According to the obtained results, in the 0-10 and 10-20 cm layers, they were 15.2 and 17.5 percent, hardness 0.88 and 1.54 MPa, and density 1.12 and 1.15 g/cm<sup>3</sup>, respectively.



**Figure 2.** General views of the leveler in operation (a) and transport (b).



**Figure 3.** A view of the leveler in operation

The results obtained in the tests were processed using mathematical statistics methods [15, 16].

### 3. Results and discussions

The test results are presented in Table 3. It can be seen from them that the quality indicators of the comprehensive grinder-leveler equipped with trace softeners, developed at both speeds, fully correspond to the initial requirements. The working depth of the trail softener is 19.6 cm at a speed of 6 km/h, and 19.3 cm at a speed of 8 km/h. 3 percent, and at a speed of 8 km/h it was 88.1 percent (according to the initial requirements, this indicator should be at least 80 percent), the density of the soil in the 5-15 cm layer at a speed of 6 and 8 km/h at the place where the softeners passed, respectively 1.16 and 1.14 g/cm<sup>3</sup>, and 1.18 and 1.16 g/cm<sup>3</sup> in the place where the softener did not pass (according to the initial requirements, it should be 1.1-1.2 g/cm<sup>3</sup>), the heights of irregularities on the field surface the mean square deviation was  $\pm 1.73$  cm at a speed of 6 km/h, and  $\pm 1.64$  cm at a speed of 8 km/h (according to the requirements, this indicator should not exceed  $\pm 2$  cm).

At the operating speeds set in the tests, i.e., at speeds of 6-8 km/h, the comprehensive grind-leveler equipped with rut softeners and a device has a basic time productivity of 4.96-6.24 ha/h, an operational productivity of 3.77-4.74 ha/hour, fuel consumption. It was 4.0-4.4 kg/ha.

In the tests, the pilot copy of the comprehensive grinder-leveler, equipped with track softeners and a device, reliably performed the specified technological process, and its serious shortcomings were not observed.

**Table 3.** Results of extensive field tests of a road roller equipped with track softeners

The name of the pointers	The value of indicators		
	According to the initial requirements	According to the test results	
Unit speed, km/h	6-8	6.2	7.8
Depth of softening of traces:			
$M_a$ , cm	20±2	19.6	19.3
±σ, cm	± 2	1.55	1.68
Fertilization quality of the soil, %			
>50	–	3.3	3.1
50-25	–	11.4	8.8
<25	> 80	85.3	88.1
Density of the soil in a layer of 5-15 cm, g/cm <sup>3</sup> :			
- from where the trail softener passed	1.1-1.2	1.16	1.14
- from the place where the trace softener did not pass	1.1-1.2	1.18	1.16
Mean square deviation of heights of irregularities on the field surface, ± cm	<2	1.73	1.64
Productivity, yes/no:			
- in prime time	4.80-6.40	4.96	6.24
- during operation	3.65-4.86	3.77	4.74
Fuel consumption, kg/ha	–	4.2	4.6

When the developed grinder-leveler is used in the preparation of land for planting, the productivity increases by 1.5-1.7 times, and the consumption of labor and fuel-lubricants in preparing the land for planting decreases by 1.4-1.5 times.

#### 4. Conclusions

The comprehensive leveler developed is equipped with track softeners and devices that create a soft layer on the field surface. It reliably performed the technological process specified in the tests, and no serious defects were observed.

The use of a comprehensive suspension trowel-leveler, equipped with devices that quickly and easily adjust the pressure on the soil and create a soft soil layer on the surface of the field, increases the productivity by 1.5-1.7 times and reduces the labor and fuel consumption when preparing the land for planting. reduces the consumption of materials by 1.4-1.5 times.

#### References

- [1] Tukhtakuziev A, et al. 2023 *E3S Web of Conferences* **390** 01038
- [2] Abdulkhaev K G and Barlibaev S N 2023 *IOP Conference Series: Earth and Environmental Science* **1154(1)** 012058
- [3] Tukhtakuziev A, Ishmuradov S 2023 *E3S Web of Conferences* **390** 01039
- [4] Turdaliyev V M, et al. 2022 *IOP Conference Series: Earth and Environmental Science* **1112** 012024
- [5] Umurzakov A K, et al. 2022 *Russian Engineering Research* **42(8)** 791–3
- [6] Turdaliyev V M, et al. 2022 *Russian Engineering Research* **42** 57–9
- [7] Borotov A, et al. 2023 *E3S Web of Conferences* **390** 04038
- [8] Shaymardanov B, et al. 2020 *IOP Conference Series: Materials Science and Engineering* **883**

012111

- [9] Norchayev D R, et al. 2022 *IOP Conference Series: Earth and Environmental Science* **1076** 012029
- [10] Kiyamov A, et al. 2021 *E3S Web of Conferences* **264** 03036
- [11] Norchayev D R, et al. 2021 *IOP Conference Series: Earth and Environmental Science* **868** 012059
- [12] Irisov Kh, et al. 2023 *E3S Web of Conferences* **386** 03003.
- [13] Irisov K et al. 2022 *IOP Conf. Ser.: Earth Environ. Sci.* **1076** 012011
- [14] Berdimurodov U et al. 2023 *E3S Web of Conferences* **365** 04012
- [15] Kobzar A I 2006 *Applied mathematical statistics* (Moscow)  
Johnson N, Lyon F 1990 *Statistics and planning of experiments in engineering and science* (Moscow)