

Mathematical and simulation modeling of a synchronous generator for micro hydroelectric and low-speed wind power plants

Sherzod Toshev^{1*}, *Shaxnoza Tosheva*², *Abror Saodullaev*³, *Sevara Tengelova*¹

¹Department of Power Supply and Renewable Energy Sources, National Research University TIIAME, Kari Niyazov str. 39, 100000 Tashkent, Uzbekistan

²Joint-Stock Company «UZENERGYENGINEERING», M. Ashrafi str.1st lane 9, 100076 Tashkent, Uzbekistan

³Jizzakh Polytechnic Institute, Islam Karimov str. 4, 130100 Jizzakh, Uzbekistan

Abstract. In this article, in conditions where environmental deterioration and energy shortages are observed throughout the world, a mathematical model for improving and developing new types of synchronous generators for low-speed wind power plants and micro-hydroelectric power plants is developed free of charge extraction of running water and simulation processes. As a result of mathematical and simulation modeling of a synchronous generator, it is based on the analysis of electromagnetic processes and the study of improvement issues to ensure its efficient operation at low speeds. In mathematical modeling, the electromagnetic processes of a low-speed synchronous generator were analyzed using mathematical equations. For this purpose, mathematical and simulation models of an improved generator designed for low speed were developed and research was carried out. The article creates a mathematical model based on the Park-Gorev equations of asymmetric modes of a synchronous generator designed to generate electricity from low-speed wind and freely flowing water. The mathematical model of the generator was expressed in the Simulink package and a simulation model was built, research was carried out and characteristics were obtained.

1. Introduction

The article describes the results obtained on the basis of a number of research works to improve the design of a low-speed wind power plant and a synchronous generator designed to produce electricity from bulk water. As a result of theoretical and applied scientific research [1-4], the effectiveness of making changes to the design of the rotor of a synchronous generator was shown. To speed up and facilitate the analysis of operating conditions of a synchronous generator, mathematical and simulation models have been developed.

Today, one of the urgent tasks is to improve low-speed generators that generate electricity using renewable energy sources, that is, wind or water energy, to produce electricity from low-speed water and wind, as well as the development of new types of generators [5-9, 11]. For this purpose, electromagnetic processes of a low-speed generator [10] are studied and analyzed using mathematical and simulation models. The main magnetic field of the low-speed generator considered in this article is created by neodymium permanent magnets and additional transverse excitation coils, controlled at the required time [1-4]. Much work is being done to develop and improve low-speed synchronous generators used to convert low-speed wind energy and free water into electricity [1-4, 6-9].

Several leading universities in the world are conducting research to improve synchronous generators that convert wind and water energy into electricity, studying electromagnetic processes, developing and creating effective technologies for their use [6-9,10]. The energy sector is widely developing in the Republic of Uzbekistan. It's not just hydrocarbons that are being built, such as oil and gas, solar, wind and hydroelectric power plants.

Over the past 5 years, Uzbekistan has been a leader among the CIS countries in commissioning new hydroelectric power plants. Over the past 5 years, 11 new hydroelectric power stations have been built and put into operation in Uzbekistan, and 9 hydroelectric power stations have been modernized and put into operation with new capacity.

*Corresponding author: tshe100679@gmail.com

Research has shown that the energy potential of low-speed winds and free-flowing beds and rivers in countries around the world is enormous.

The article explores the study of various operating modes and electrical quantities of a low-speed synchronous generator using model in the MatLab package [12].

2. Materials and Methods

A mathematical model based on the Praka-Gorev equations of the operating mode of a micro-hydroelectric power station and a synchronous generator of a low-speed wind power plant intended for the production of electricity from bulk water is expressed, and modeling is carried out. The model was built in the Simulink package.

In this case, when creating and simplifying the mathematical model of a synchronous generator in phase coordinates, we compose equations taking into account the stator and transverse and longitudinal excitation coils.

Single-phase short-circuit mode conditions of a low-speed synchronous generator:

$$U_a = 0, \quad i_b = i_c = 0 \tag{1}$$

will be equal to. In this case, the equation for the magnetic flux linkage equation of the stator winding of a small speed synchronous generator:

$$\left. \begin{aligned} \frac{d\psi_d}{dt} - \omega_r \cdot \psi_q - (2r_c + 3r_k) \cdot i_d &= 0 \\ \frac{d\psi_q}{dt} + \omega_r \cdot \psi_d - (2r_c + 3r_k) \cdot i_q &= 0 \end{aligned} \right\} \tag{2}$$

we write in the form [1-4,10].

In the single-phase short-circuit mode of a low-speed synchronous generator, the stator circuit magnetic flux linkage equation is as follows [1-4]:

$$\left. \begin{aligned} \psi_d &= X_{ad} \cdot (1 + \cos 2\gamma_r) \cdot (i_{fd} + i_{1d}) - \\ &- X_{ad} \cdot \sin 2\gamma_r \cdot (i_{fq} + i_{1q}) - 2(X_d + X_k) \cdot i_d \\ \psi_q &= -X_{ad} \cdot \sin 2\gamma_r \cdot (i_{fd} + i_{1d}) - \\ &- X_{aq} \cdot (1 - \cos 2\gamma_r) \cdot (i_{fq} + i_{1q}) - 2(X_d + X_k) \cdot i_q \end{aligned} \right\} \tag{3}$$

Using the magnetic flux linkage equation of a single-phase short-circuit mode of a low-speed synchronous generator, we will construct a subsystem in the Simulink package.

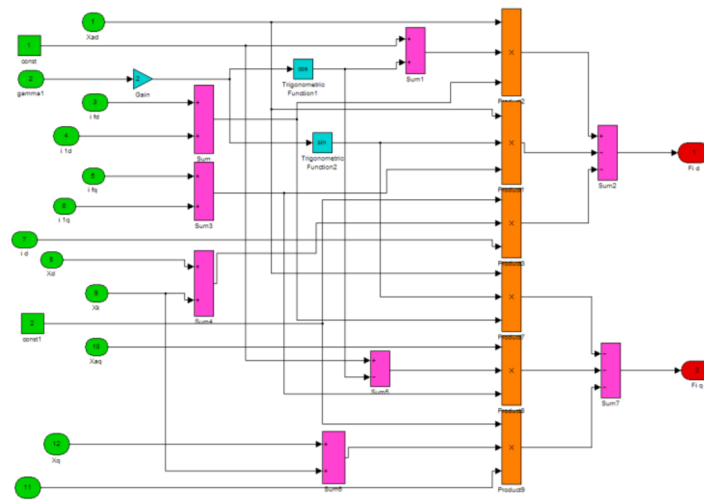

Fig. 1. Low-speed synchronous generator single-phase short-circuited stator magnetic flux linkage subsystem in Simulink package

Figure 1 shows a Simulink subsystem based on the mathematical equations of the magnetic flux linkage of a permanent magnet and transverse excitation winding in a single-phase short-circuit mode of a low-speed synchronous generator. Using these mathematical equations and the simulation subsystem, the processes of the magnetic flux coupling in the single-phase short-circuit mode of the low-speed synchronous generator were analyzed.

Low-speed synchronous generator two-phase short-circuit mode conditions:

$$U_b - U_c = 0, \quad i_b = -i_c = i, \quad i_a = 0 \tag{4}$$

is equal to. Here the equation for the magnetic flux linkage of a low-speed synchronous generator stator winding:

$$\left. \begin{aligned} \frac{d\psi_d}{dt} - \omega_r \cdot \psi_q - (r_c + r_k) \cdot i_d &= 0 \\ \frac{d\psi_q}{dt} + \omega_r \cdot \psi_d - (r_c + r_k) \cdot i_q &= 0 \end{aligned} \right\} \tag{5}$$

we will write it down [1-4, 10]. In the two-phase short-circuit mode of a low-speed synchronous generator, the stator winding magnetic flux linkage equation is as follows [1-4]:

$$\left. \begin{aligned} \psi_d &= \frac{X_{ad}}{2} \cdot (1 - \cos 2\gamma_r) \cdot (i_{fd} + i_{1d}) + \\ &+ \frac{X_{ad}}{2} \cdot \sin 2\gamma_r (i_{fq} + i_{1q}) - X_d \cdot i_d \\ \psi_q &= \frac{X_{ad}}{2} \cdot \sin 2\gamma_r \cdot (i_{fd} + i_{1d}) + \\ &+ \frac{X_{aq}}{2} \cdot (1 + \cos 2\gamma_r) \cdot (i_{fq} + i_{1q}) - X_q \cdot i_q \end{aligned} \right\} \tag{6}$$

Of the equations of the magnetic flux linkage of the stator circuit in the two-phase short-circuit mode of the low-speed synchronous generator is constructed a subsystem in the Simulink package.

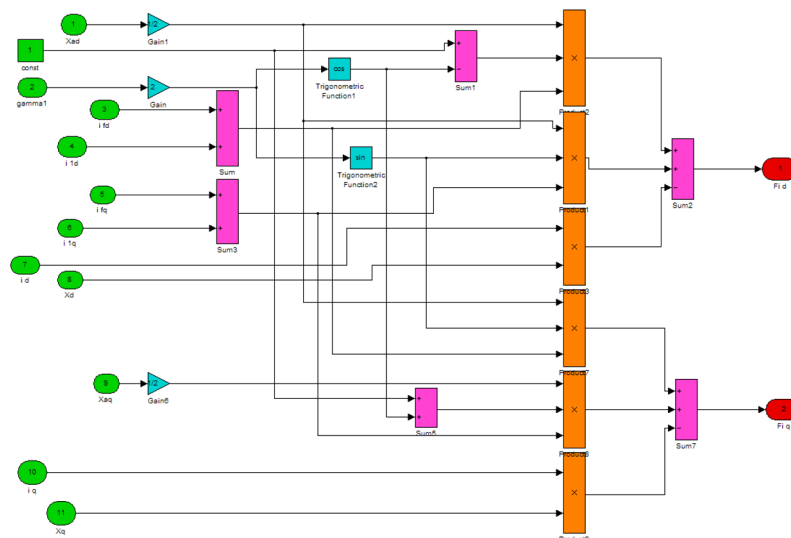

Fig. 2. A subsystem of the Simulink package of the stator magnetic flux linkage in a two-phase short-circuit of a low-speed synchronous generator

Figure 2 presents the Simulink subsystem based on the mathematical equations of the magnetic flux coupling of a permanent magnet and a transverse excitation winding in the two-phase short-circuit mode of a low-speed

synchronous generator. Using these mathematical equations and the simulation subsystem, the processes of the magnetic flux coupling in the two-phase short-circuit mode of the low-speed synchronous generator were analyzed. Low-speed synchronous generator two-phase zero short-circuit mode conditions:

$$U_b = U_c = 0, \quad i_a = 0 \tag{7}$$

will be equal to. Here the equation for the magnetic flux linkage of a low-speed synchronous generator stator winding:

$$\left. \begin{aligned} \frac{d\psi_d}{dt} - \omega_r \cdot \psi_q - (r_c + 3r_k) \cdot i_d &= 0 \\ \frac{d\psi_q}{dt} + \omega_r \cdot \psi_d - (r_c + 3r_k) \cdot i_q &= 0 \end{aligned} \right\} \tag{8}$$

we will write it down [1-4, 10].

In the low-speed synchronous generator two-phase zero short-circuit mode, the stator circuit magnetic flux linkage equation is [1-4]:

$$\left. \begin{aligned} \psi_d &= \frac{X_{ad}}{2} \cdot (1 + \cos 2\gamma_r) \cdot (i_{fd} + i_{1d}) + \\ &+ \frac{X_{ad}}{2} \cdot \sin 2\gamma_r \cdot (i_{fq} + i_{1q}) - (X_d + 2X_k) \cdot i_d \\ \psi_q &= \frac{X_{ad}}{2} \cdot \sin 2\gamma_r \cdot (i_{fd} + i_{1d}) + \\ &+ \frac{X_{aq}}{2} \cdot (1 - \cos 2\gamma_r) \cdot (i_{fq} + i_{1q}) - (X_q + 2X_k) \cdot i_q \end{aligned} \right\} \tag{9}$$

Low-speed synchronous generator two-phase zero-

short-circuit stator circuit magnetic flux linkage equations subsystem in Simulink package is constructed.

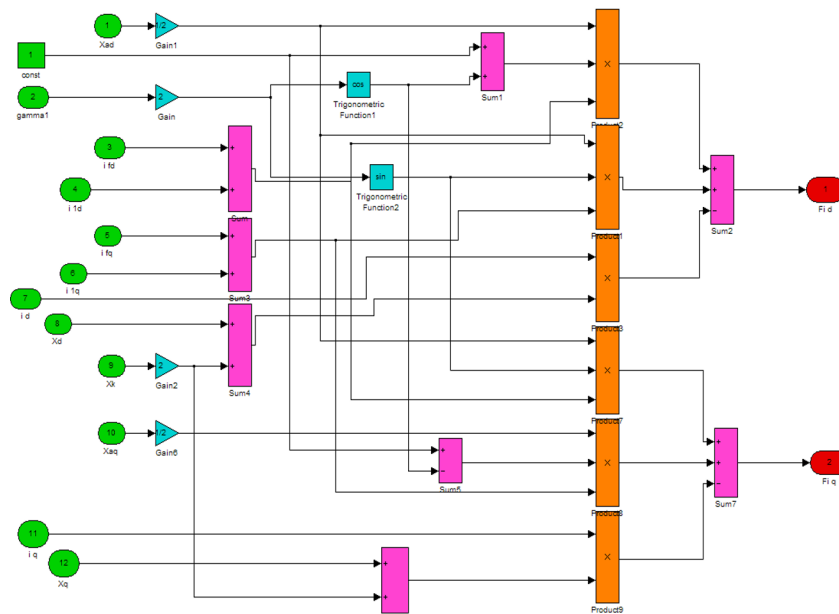

Fig. 3. Low-speed synchronous generator two-phase zero short-circuit stator magnetic flux linkage subsystem in Simulink package

Figure 3 shows the Simulink subsystem based on the mathematical equations of the magnetic flux coupling of a permanent magnet and a transverse excitation coil in the two-phase zero short-circuit mode of a low-speed synchronous generator. Using these mathematical equations and the simulation subsystem, the processes of the magnetic flux coupling in the two-phase zero short-circuit mode of the low-speed synchronous generator were analyzed.

We write down the voltages of the symmetrical stator winding of the low-speed synchronous generator as follows [1-4, 10]:

$$\begin{aligned}
 U_a &= \left(\frac{d\psi_d}{dt} - \psi_q \right) \cos \gamma - \left(\frac{d\psi_q}{dt} + \psi_d \right) \sin \gamma \\
 U_b &= \left(\frac{d\psi_d}{dt} - \psi_q \right) \cos(\gamma - 120^\circ) - \left(\frac{d\psi_q}{dt} + \psi_d \right) \sin(\gamma - 120^\circ) \\
 U_c &= \left(\frac{d\psi_d}{dt} - \psi_q \right) \cos(\gamma + 120^\circ) - \left(\frac{d\psi_q}{dt} + \psi_d \right) \sin(\gamma + 120^\circ)
 \end{aligned}
 \tag{10}$$

The overvoltage equation in a two-phase short circuit of a low-speed synchronous generator [1-4, 10]:

$$\begin{aligned}
 U_a &= \left(\frac{d\psi_d}{dt} - \psi_q \right) \cos \gamma - \left(\frac{d\psi_q}{dt} + \psi_d \right) \sin \gamma \\
 U_b &= -\frac{1}{2} U_a \\
 U_c &= -\frac{1}{2} U_a
 \end{aligned}
 \tag{11}$$

Here, ψ_d, ψ_q , are obtained from equation (6) above for the two-phase short-circuit mode, respectively. We express the two-phase short-circuit overvoltage equation (11) of a low-speed synchronous generator in the Simulink package..

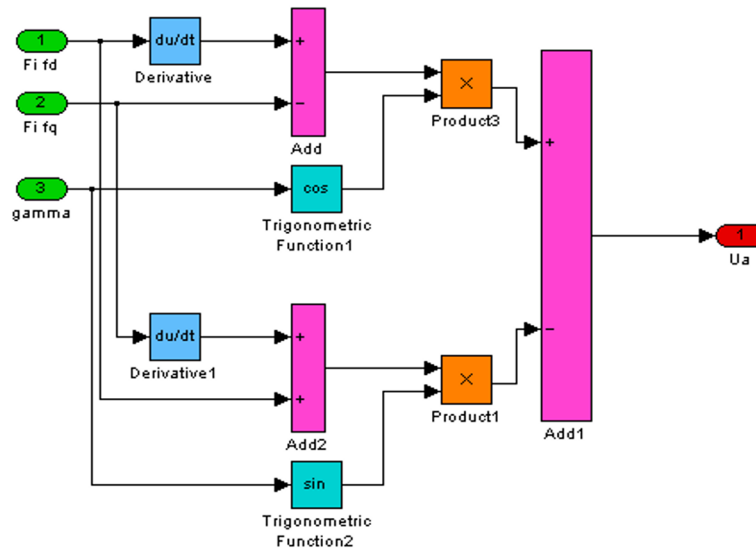

Fig. 4. Low-speed synchronous generator open-phase voltage in two-phase short-circuit mode Simulink subsystem

Figure 4 shows the Simulink subsystem based on open-phase overvoltage mathematical equations in two-phase short-circuit mode of a low-speed synchronous generator. Using these mathematical equations and the simulation subsystem, the overvoltage processes in the open phase of the two-phase short-circuit mode of the low-speed synchronous generator were analyzed.

Voltage equation in a single-phase short circuit of a low-speed synchronous generator:

$$U_b = \left(\frac{d\psi_d}{dt} - \psi_q \right) \cos(\gamma - 120^\circ) - \left(\frac{d\psi_q}{dt} + \psi_d \right) \sin(\gamma - 120^\circ) \tag{12}$$

$$U_c = \left(\frac{d\psi_d}{dt} - \psi_q \right) \cos(\gamma + 120^\circ) - \left(\frac{d\psi_q}{dt} + \psi_d \right) \sin(\gamma + 120^\circ)$$

Here, ψ_d, ψ_q , respectively, are found from equation (3) for the single-phase short-circuit mode. And we express the equation (12) in the Simulink package.

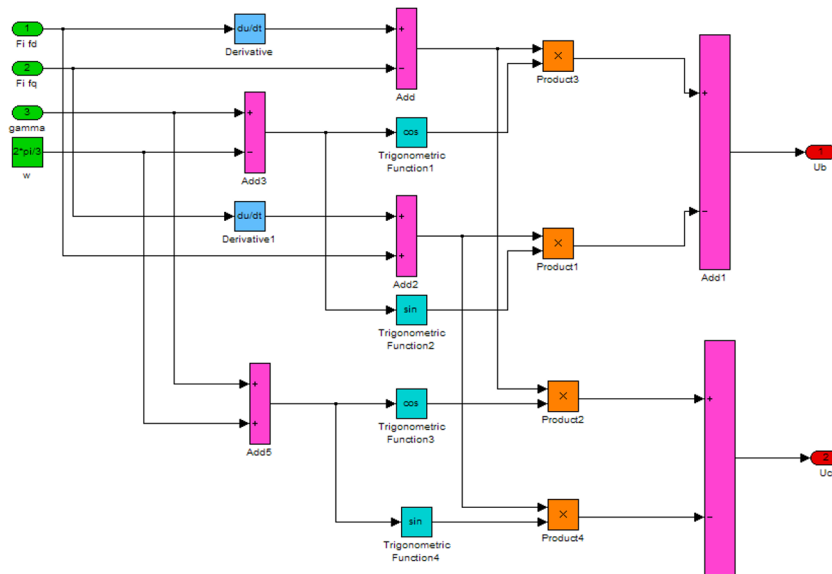

Fig. 5. Low-speed synchronous generator single-phase short-circuit mode overvoltage in open phases Simulink subsystem

Figure 5 presents a Simulink subsystem based on open-phase overvoltage mathematical equations in a single-phase short-circuit mode of a low-speed synchronous generator. Using these mathematical equations and the simulation subsystem, the overvoltage process in the open phases of the low-speed synchronous generator in the single-phase short-circuit mode is analyzed.

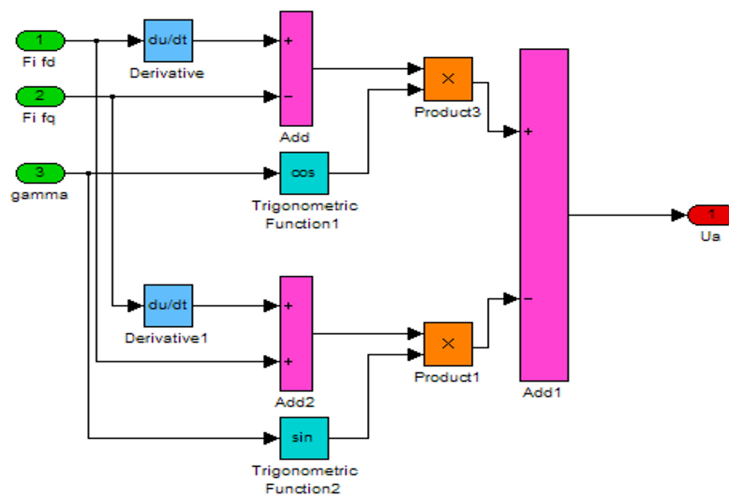

Fig. 6. Open-phase overvoltage simulink subsystem in two-phase zero short-circuit mode of low-speed synchronous generator

Open-phase overvoltage equation for a two-phase zero short-circuit of a low-speed synchronous generator:

$$U_a = \left(\frac{d\psi_d}{dt} - \psi_q \right) \cos \gamma - \left(\frac{d\psi_q}{dt} + \psi_d \right) \sin \gamma \quad (13)$$

Here ψ_d, ψ_q s are found from the equation (9) for the two-phase zero short-circuit mode. We express the above equation (13) in the Simulink package.

Figure 6 shows the Simulink subsystem based on open-phase overvoltage mathematical equations in two-phase zero short-circuit mode of a low-speed synchronous generator. Using these mathematical equations and the simulation subsystem, the open-phase overvoltage process of the two-phase zero short-circuit mode of the low-speed synchronous generator is analyzed.

3. Results and Discussion

Using the Simulink subsystems built on the basis of the stator chain magnetic flux coupling and overvoltage equations in the asymmetric short-circuit modes of the above generator, we build a simulation model for studying the operating modes of a low-speed generator.

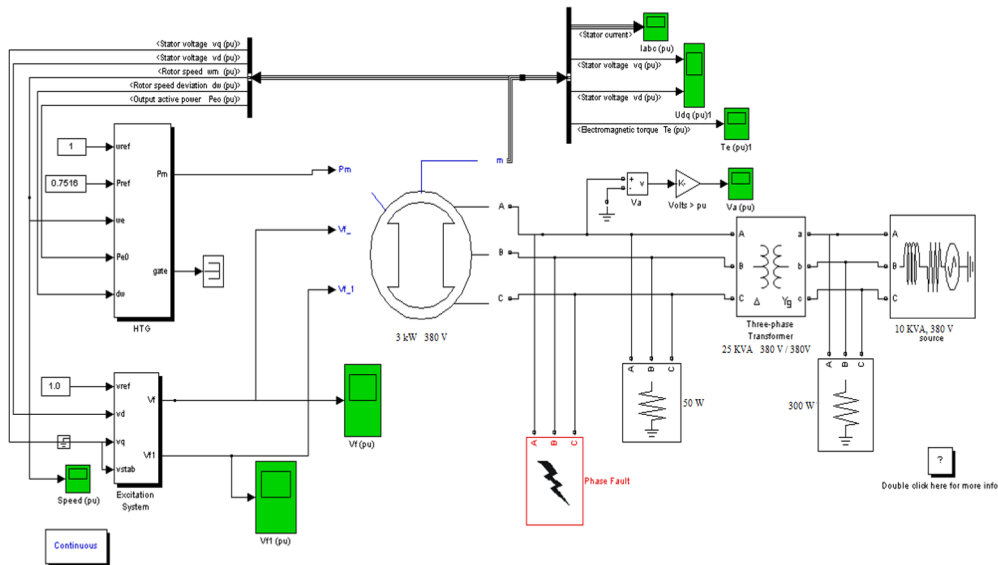

Fig. 7. A simulation model for studying the operating modes of a low-speed generator

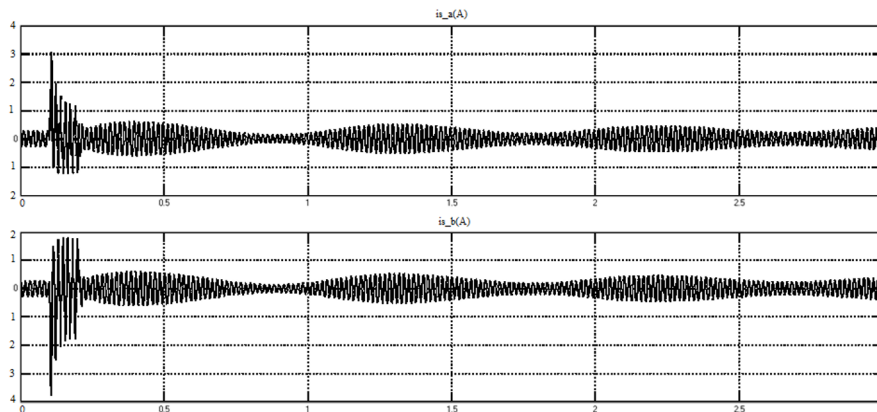

Fig. 8. Graph of phase currents in two-phase short-circuit mode of a low-speed generator

Figure 7 shows the simulation model of the stator circuit of the small speed synchronous generator based on the magnetic flux linkage and overvoltage equations and Simulink subsystems. With the help of this simulation model of a low-speed synchronous generator, the stator circuit magnetic flux coupling and overvoltage processes were analyzed.

Below, as a result of the study of a low-speed synchronous generator carried out using the simulation model, the graphs of short-circuit currents and open-phase overvoltages in asymmetric operating modes are obtained in Figures 8, 9, 10.

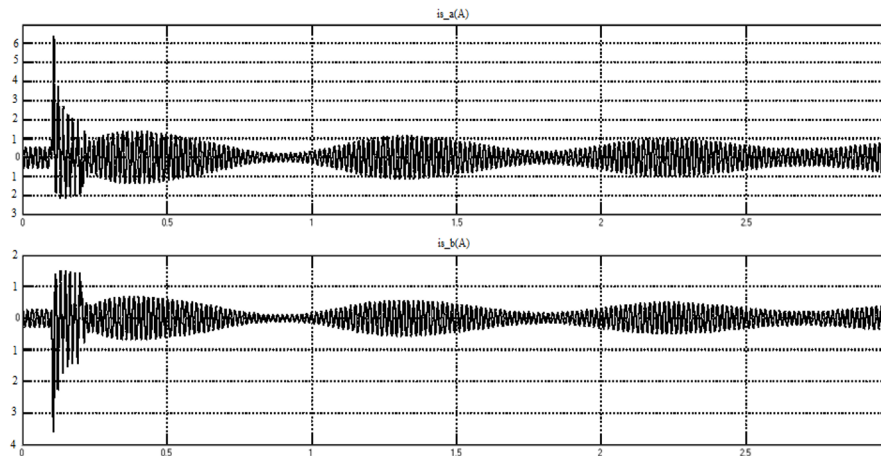

Fig. 9. Graph of phase currents in two-phase zero short-circuit mode of a low-speed generator

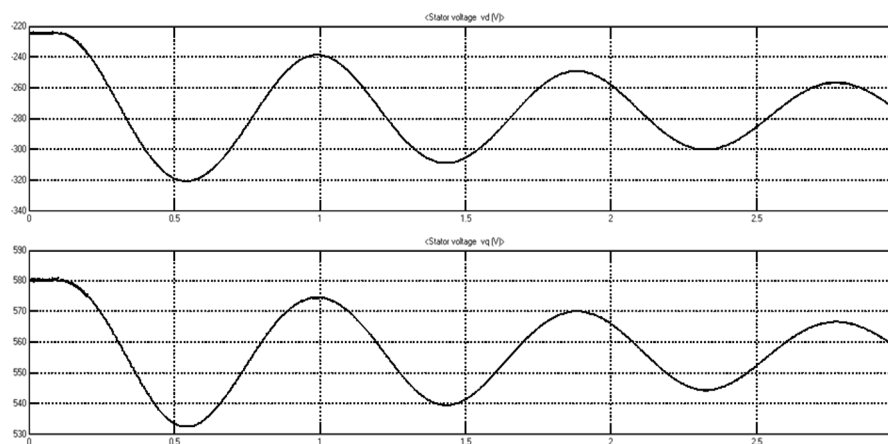

Fig. 10. Graph of phase voltages in single-phase short-circuit mode of a low-speed generator

4. Conclusions

- a) The article is relevant in that it analyzes mathematical and simulation modeling processes for the development of new types of synchronous generators designed for micro-hydroelectric power generation and low-speed wind power plants, as well as the study of operating modes.
- b) One of the advantages of this generator, which is designed for micro-hydroelectric power plants and low-speed wind power plants for the production of electricity from free-flowing water, is low-speed construction.
- c) With the help of mathematical and simulation models of this low-speed synchronous generator, it is possible to study its electromagnetic processes together with research. According to the results of the research carried out using mathematical and simulation models of the low-speed generator, it was determined that the efficiency of electricity generation from free-flowing water and low-speed winds is high.
- d) In addition, when working modes are studied with the help of mathematical and simulation models, one of the important features is the relatively quick relaxation of transient processes during symmetric loading and short circuit times.

References

1. Toshev Sh.E., Tosheva Sh.N., Sadullaev A., Vokhidov A. Study on a generator and turbine designed for an efficient wind power plant in low speed wind currents. *E3S Web of Conferences* **434**, 01025 (2023)
2. Pirmatov N.B., Toshev Sh.E., Tosheva Sh.N., Egamov A. Low-speed generator of new type, used for production of electrical energy and basic renewable energy sources, International scientific conference, Tashkent (2018)

3. Pirmatov N., Tosheva Sh., Toshev Sh., Best overall dimensions of synchronous generator with permanent magnets for small power wind plants and micro hydropower plants. *E3S Web of Conferences* **139**, 01027 (2019)
4. Pirmatov N., Toshev Sh., Overvoltage in the free phase of the stator winding in case of asymmetric short circuit implicit pole synchronous generator biaxial excitation. *E3S Web of Conferences* **139**, 01030 (2019)
5. Pirmatov N., Toshev Sh., Tosheva Sh., Mustafakulova G. Small-speed synchronous generator with rotating magnetization axis. Utility model patent. No. FAP 01558 (2020)
6. Aner, Mohamed, Improved MPPT Dynamics for Starting and Power Extraction of a Small Wind Turbine Employing a PMSG and a VSMC, PhD Dissertation, University of Calgary, Calgary (2014)
7. Krivtsov V.S., Oleinikov, A.M., Yakovlev, A.I. Inexhaustible energy, Prince. 1. Wind power generators: Textbook, Kharkiv Aviation Institute, Kharkiv (2003)
8. Fediy K.S., Fediy A.L., Vstovsky K.S. Analysis and calculation of synchronous machines with excitation from permanent magnets, Optimization of operating modes of electrical systems, CPI KSTU, Krasnoyarsk (2006)
9. Balagurov V.A., Galteev F.F. Electric generators with permanent magnets, Energoatomizdat, Moscow (1988)
10. Allaev K.R. Transient electromechanical processes, Moliya Publisher, Tashkent (2007)
11. Khaidarov S.Zh., Toshev Sh.E. Analysis of overvoltages arising from asymmetrical short circuits in a synchronous biaxial excitation turbogenerator. *Bulletin of Tashkent State Technical University* **1**, 68-74 (2016)
12. Chernykh I.V. Modeling of electrical devices in MATLAB, SimPowerSystems and Simulink, DMK Press; St. Petersburg (2008)