

PAPER • OPEN ACCESS

Application of hydro energy in small power supply systems

To cite this article: D Kodirov *et al* 2020 *IOP Conf. Ser.: Earth Environ. Sci.* **614** 012037

View the [article online](#) for updates and enhancements.

Application of hydro energy in small power supply systems

D Kodirov^{1*}, O Tursunov^{1,2,3}, Kh Karimova⁴, N Akramova⁵, S Parpieva¹, and B Shafkarov⁶

¹Department of Power Supply and Renewable Energy Sources, Tashkent Institute of Irrigation and Agricultural Mechanization Engineers, 100000 Tashkent, Uzbekistan

²School of Mechanical and Power Engineering, Shanghai Jiao Tong University, 200240 Shanghai, China

³Research Institute of Forestry, 111104 Tashkent, Uzbekistan

⁴Department of Information Technologies, Tashkent Institute of Irrigation and Agricultural Mechanization Engineers, 100000 Tashkent, Uzbekistan

⁵Department of Accounting and Audit, Tashkent Institute of Irrigation and Agricultural Mechanization Engineers, 100000 Tashkent, Uzbekistan

⁶Department of Management, Tashkent Institute of Irrigation and Agricultural Mechanization Engineers, 100000 Tashkent, Uzbekistan

*Email: d.kodirov@mail.ru

Abstract. This paper provides an opportunity to increase the efficiency of use in low-pressure watercourse systems by determining the dimensions and design of the micro-hydroelectric power plant operating on low-pressure watercourses. It was found that the size of a micro-hydro water turbine depends on the flow rate of the water, the volume of water hitting the blade at a fixed time, and the depth of the water surface. As a result, a technological scheme of a micro-hydroelectric power plant operating on low-pressure water streams was developed.

1. Introduction

A micro-hydroelectric power plant operating at low pressure watercourses generates electricity by using the energy of the water flowing from a lower height more efficiently than existing hydro turbines. However, given the limited mechanical strength of its shaft, it is advisable to find and apply the most effective technical solutions. In addition, for the device to work effectively, it is necessary to pay attention to the compactness of the structure, its durability, susceptibility to natural disasters and climate change, and other aspects [1-14].

It is advisable to build a micro-hydroelectric power plant, taking into account the volume of flowing water and its height. The main thing is that if the sides of the paddle are closed and the outside of the paddles is created below the plane of the incoming water flow, the water jet can fully transfer its kinetic energy to the paddles, resulting in increased mechanical strength. In this case, the stream of water flow should be designed in such a way that the volume of water flow should be fully directed to the wheel [1, 2, 4-6].

When designing an energy efficient microhydroelectric power plant operating at low pressure water flows, we need to develop the most efficient simple design. In this case, taking into account the dynamic effects of water flowing in the horizontal free plane, it is necessary to develop the initial appearance in a



computer program and perform calculations on this basis, choosing the correct shape and size of the wing that cover the flow and volume of water as much as possible.

2. Methodology

Initially, we choose a relatively simple technological form (construction) that retains (covers) water and performs mechanical work from the point of maximum distance of the vertical line passing through the axis of the micro-hydroelectric power plant (Figure 1).

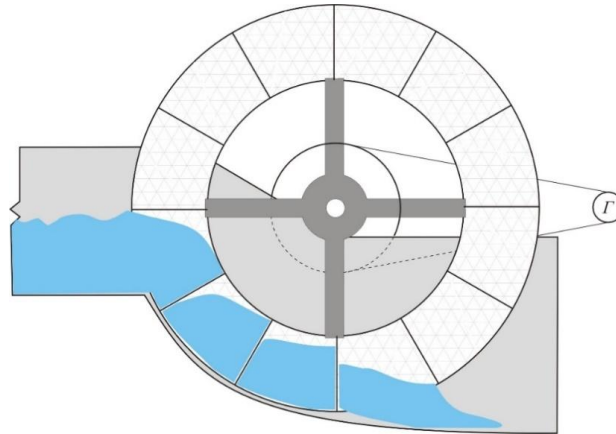

Figure 1. Preliminary view of a micro-hydroelectric power plant operating at low pressure water flows

The energy efficiency is not high in conventional blades placed along the radius of the blades [1, 2, 4, 7, 12, 13] because the weight of the water flows freely from top to bottom and the blades encounter resistance during the ascent from the water. Therefore, we change this initial pattern at a certain slope relative to the outer radius and consider the physical properties of the forces acting on it.

Adjusting the speed will not be so complicated when the hydro-electric water wheel reaches its independent speed. The speed of the water wheel is slow but this can be increased in two ways. The first is to use a gearbox that is suitable for the speed of rotation of the wheel. Low energy (up to 97% efficiency) is lost in the gearbox produced today. The second is multi-pole rotational low-speed generators, the development of which today makes it possible to solve problems in this area.

The efficiency of conventional blades placed along the radius of the blades is low because the weight of the water flows freely from top to bottom and the blades encounter resistance during the ascent from the water. Therefore, we modify these initial sample blades at a certain slope relative to the outer radius and consider the physical properties of the forces acting on it (Figure 2) [3].

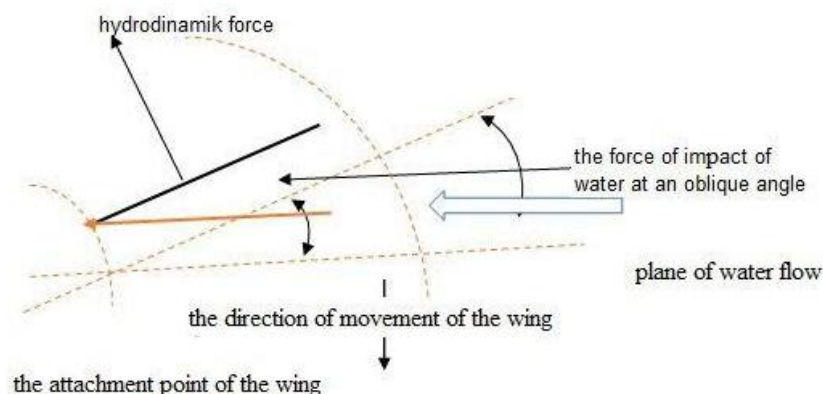

Figure 2. Selection of feathers taking into account water flow

As can be seen from the picture above, the plane of the water flow is moving in the direction in which the spindle blades are placed along the radius. In this case, the kinetic energy of the water is directed to its axis, not to the blades, which leads to an increase in hydrodynamic force. In doing so, the water in the wheel loses some of its speed and energy by acting against the centrifugal forces. This energy is converted into useful mechanical energy in the wheel shaft.

Another important angle parameter is the angle between the base on which the blade is attached and the direction of the incoming water flow, which is zero. The hydrodynamic force generated in the blade was directed at the blades, not at its base (Figure 3).

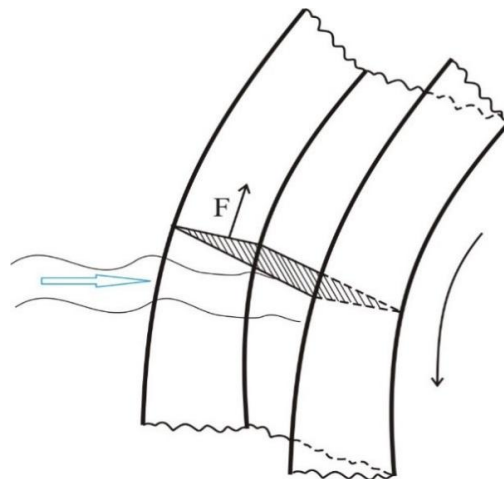

Figure 3. The effect of water flow on the wing

The hydrodynamic force is greater in inclined blades than in blades that are in line with the outer radius [5]. But bubble wing are an exception. Because of the rapid rotation of the convex wing, there is a risk of complete failure of the water during the spill due to the law of gravity, which leads to a loss of mechanical energy [6, 8, 14]. Therefore, corner blades suitable for the device are the most sensible solution for hydrodynamic profiles (Figure 4).

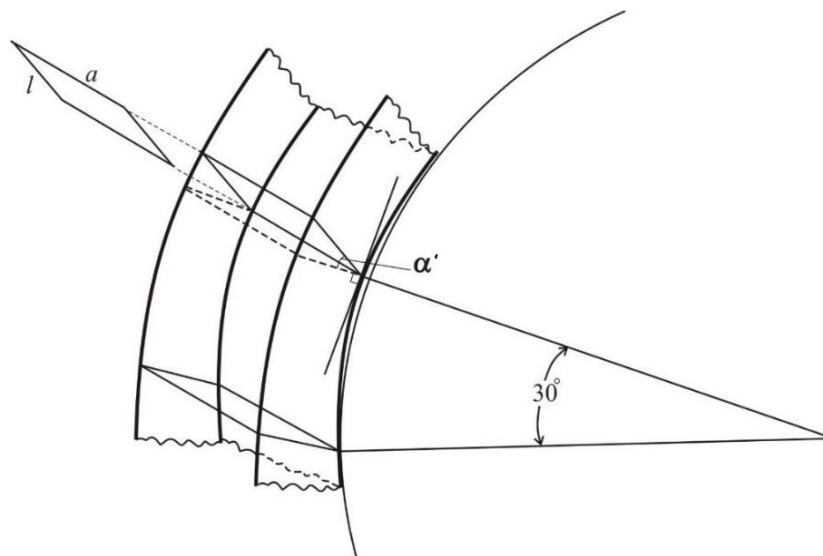

Figure 4. The location of an angle a corresponding to the dimensions of the wheel

The angle of placement of the blades is the angle between the base on which the blades are attached and the direction of motion perpendicular to the effort relative to the rotational speed.

The second important angle parameter is the angle between the wing-fixed foundation and the direction of incoming water flow.

The hydrodynamic force generated in the blade is perpendicular to its base.

The fact that the blade is at an oblique angle affects the change in its hydrodynamic properties. That is, the force generated when a stream of water collides with a blade depends on the angle of the blade.

The hydrodynamic force is greater in inclined blades than in blades that are in line with the outer radius [9]. But convex wing are an exception. This is because as a result of the rapid rotation of the convex wing, there is a risk of water not remaining completely when spilled under the law of gravity, resulting in a loss of mechanical energy between the blades. Therefore, corner blades suitable for the device are the most sensible solution for hydrodynamic profiles.

Let us consider the effect of the motion of the blade on the character of its water flow. When a current collides with a stationary blade, the following can be detected:

- flow direction and angle of the blade;
- hydrodynamic force (F_o);
- the angle of its placement relative to the line of movement of the blade α ;
- force pulling the blade towards the center $F_t = F_o \cdot \sin\alpha$;
- feather strength.

The flow velocity relative to the direction of movement of the blade and the angle of flow relative to the fixed base of the blade vary. Therefore, it is necessary to find the most suitable angle.

Once the water has flowed in from the blades, it is necessary to estimate how the rotation speed of the water flow changes and its quantity. Because the sides of the wing are closed, the amount of water at the inlet and outlet is almost unchanged.

3. Results and Discussion

Taking into account the dynamic effects of free-flowing water in the horizontal plane, it is possible to make preliminary calculations of a low-pressure water-based microhydroelectric power plant based on a mathematical model and calculate the outer and inner diameters, inner and outer dimensions of the blades, number of blades and pulley diameter.

As can be seen from Figures 2 and 4 above, we can obtain the following by using the right-angled triangle holil when the blades are changed:

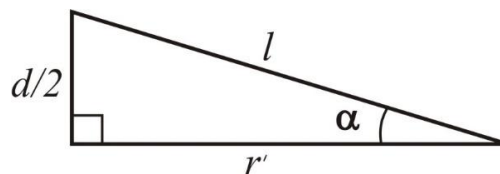

Figure 5. A triangle formed between the wings

where $d/2$ is the radius of the wheel axis; r' is the difference between large and small radius ($R-r$); α is the angle between the wings; l is the length of the newly formed feather;

From Figure 5 above we can get the following expressions:

$$\operatorname{tg} \alpha = \frac{d/2}{r'}, \quad (1)$$

We need to find its dimensions to find the angle (α) that corresponds to the wings of the microhydroelectric water wheel. First, we cannot determine the diameter (outer) of the wheel.

The diameter of the water wheel of a micro-hydroelectric power plant can be determined by the following formula [10]:

$$D = \sqrt{\frac{N}{g \cdot \eta \cdot Q \cdot H \cdot \sqrt{H}}} \quad (2)$$

Here N is the power of the micro-hydroelectric power plant (kW), g is the acceleration of free fall (9.81 m/s^2), η is the efficiency of the device (efficiency up to 0.8), H is the initial height of the water ($1 \div 2 \text{ m}$), Q is the amount of water flowing per second ($0.9 \div 1.5 \text{ m}^3/\text{s}$).

Based on the individual factors of the area where the micro-hydropower plant is planned to be installed, we can determine the capacity of the micro-hydropower plant (kW) according to the following formula [3]:

$$N = g \cdot \eta \cdot H \cdot Q \quad (3)$$

From the above formula we can get the following (values are averaged):

$$N = 9.81 \cdot 0.6 \cdot 1.5 \cdot 1.2 = 10.59 \text{ kW}$$

Now, we calculate the diameter of the micro GES water wheel:

$$D = \sqrt{\frac{10.595}{9.81 \cdot 0.6 \cdot 1.2 \cdot 1.5 \cdot \sqrt{1.5}}} = 0.9 \text{ m}$$

Rounding the obtained diameter value, we get $D = 1 \text{ meter}$.

Table 1. Dimensions of outer and inner diameters of the wheel

№	Outer diameter of the wheel, cm	Internal diameter of the wheel, cm
1	900	450
2	925	462.5
3	950	475
4	975	487.5
5	1000	500
6	1025	512.5
7	1050	525
8	1075	537.5
9	1100	550

The wheel we are developing has outer and inner diameters. Preliminary results in a sequence to determine the inner diameter size corresponding to the outer diameter of the wheel are checked using regression analysis. The dependence of the outer diameter of the wheel on its inner diameter is studied. The results of the regression analysis are presented in Table 1 and Figure 6.

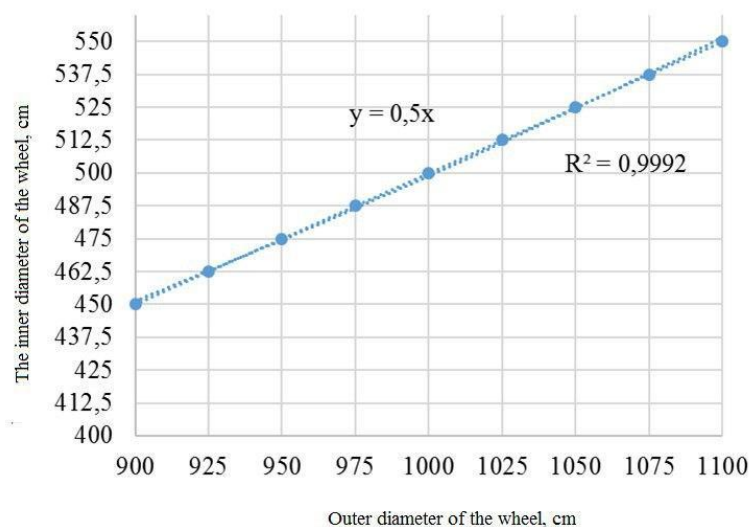

Figure 6. Correlation of outer and inner diameters of the wheel

Hence, the interdependence of the outer and inner diameters of the wheel varies according to the law of the linear equation $y = 0.5x$. The accuracy of this law is 99% (R).

According to the results of the analysis, the outer diameter of the wheel is 100 cm and its inner diameter is 50 cm.

Table 2. Regression statistics

Plural R	0.99986957
R-square	0.99984176
The standard R-square	0.99829113
Number of observations	15

This means that the outer diameter is 1000 mm and the inner diameter is 500 mm. equal to (Figure 7).

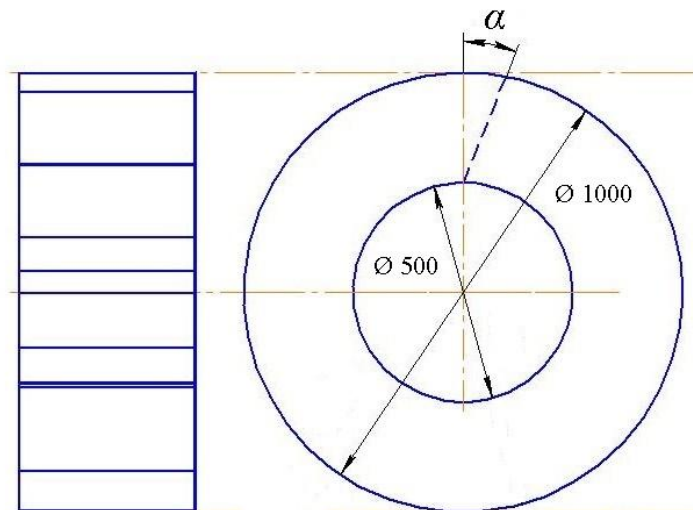

Figure 7. Dimensions of outer and inner diameters of the wheel

The diameter (d) of the micro HPS water wheel shaft can be determined by the following formula [8].

$$d = \sqrt[3]{\frac{16 \cdot M}{\pi \cdot [\tau]}} \text{ m} \quad (4)$$

Here is $[\tau] = (3 \div 5) \cdot 10^3 \text{ H} / \text{m}^2$ allowable torque for this shaft, - torque. The torque can be determined by the following formula:

$$M = 9,57 \cdot \frac{N}{n} \text{ H m} \quad (5)$$

Here N - micro HPS power (kW), n - cuv wheel number of rotations (), number of wheel turns (n) is determined by the following formula [12]:

$$n = \frac{30}{\pi} \cdot \frac{v}{r'}; \text{ rpm} \quad (6)$$

Here, v - is the flow rate (m / s), R is the radius of the wheel (m), $p = 3.14$.

$$n = \frac{30}{3,14} \cdot \frac{1,5}{0,25} = 57; \text{ rpm}$$

henceforth,

$$M = 9.57 \cdot \frac{10.59}{57.32} = 1.77 \text{ N} \cdot \text{m}$$

$$d = \sqrt[3]{\frac{16 \cdot 1,77}{3,14 \cdot 4 \cdot 10^3}} = 0,131 \text{ m}$$

This means that the diameter of the micro HPS water wheel shaft is 13.1 cm. Using this we can find the length of the blade changed to angle α .

$$\operatorname{tg} \alpha = \frac{d/2}{r'} = \frac{6,5}{25} = 0,26,$$

The tangent angle at this value was $\alpha = 15^\circ$. This angle allows to increase the energy efficiency of micro HPPs. Hence, the optimal angle of the developed micro HPS water wheel is a $\alpha = 15^\circ$. Its length (l) can be found by Pythagorean theorem.

$$l^2 = (d/2)^2 + (r')^2 \quad (7)$$

$$l = \sqrt{6,5^2 + 25^2} = 25,83$$

Thus, the feather is equal to $l = 25,83$ sm. We take the other side of the blade as 40 sm.

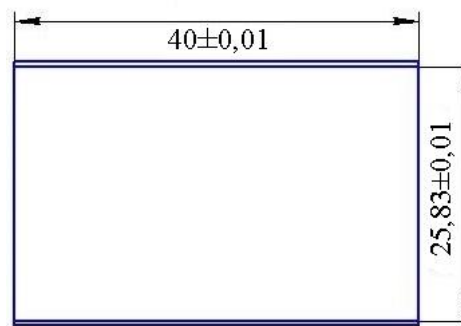

Figure 8. Dimensions of micro GES water wheel

From the above recession statistics, the outer and inner diameters of the blade as well as the dimensions of the inner and outer part of the blades are given in full in Table 3.

Table 3. Dimensions of micro-hydroelectric power plant

No	Nominal	Dimensions, mm
1	Outer diameter	$1000 \pm 3,7$
2	Internal diameter	$500 \pm 2,3$
3	The inner part of the blade	$258,3 \pm 0,01$
4	The outer part of the blade	$400 \pm 0,01$
5	The number of wing	12 ra

Figure 9 shows a 3D view of a micro-hydro water turbine based on the determined dimensions.

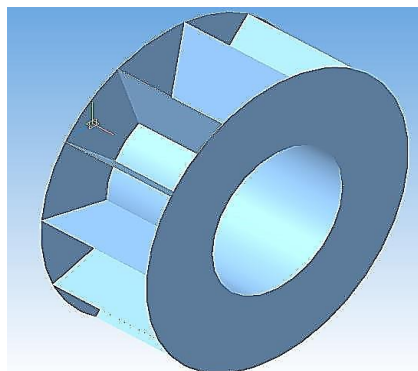

Figure 9. 3D view of a hydroelectric power plant

Due to the fact that the rotational speed of the micro-hydroelectric power plant operating in low-pressure water streams is not high (100 rpm), it is advisable to use belt drives (pulleys) and multi-pole low-speed generators.

The technological scheme of a micro-hydroelectric power plant operating at low pressure water flows based on the dimensions of the wheel in Table 1 and dimensions of micro hydroelectric power plant in Table 3 is shown in full in Figure 10.

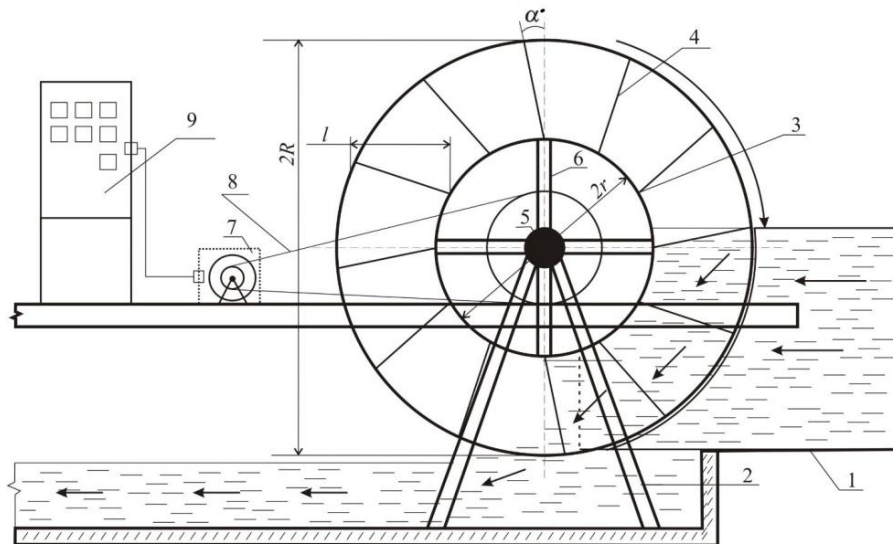

Figure 10. Technological scheme of microhydroelectric power plant operating at low pressure water flows: 1 is the water flow; 2 device frame; 3 water flow holding housing; 4-blade; 5-val; 6 steel cores; 7-generator; 8-band extension; 9 Power control block.

Figure 10 shows a cross section of a 12-blade water wheel. It is stated that the blades are placed along the radius and at a small angle relative to the radius of the blades to be mastered. As can be seen from the picture, the outer part of the 1st wing is in the process of covering the horizontal water, the 6th wing is out of the process of covering the water and the water in it is flowing.

In order to maximize the impact of water flow on the blades of the micro-hydroelectric power plant and to minimize the impact force when the blades come out of the water, the optimal value of the angle of contact of the blades with water was determined. In addition, the force and speed of rotation of the wheel can be increased as a result of the water hitting the center at an oblique angle and the blade facing less resistance at the moment of rising from the water.

5. Conclusions

The functional scheme of a low-pressure hydroelectric power plant was developed on the basis of mathematical modeling, on the basis of which a new model of a low-pressure hydroelectric power plant was created.

On the basis of mathematical modeling for the purpose of verification and testing of the device operating modes in the laboratory, the first improved sub-model of the microhydroelectric power plant operating at low pressure water flows was developed and successfully tested. The test results made it possible to develop a large-scale experimental sample of a theoretically based micro-hydro power plant.

References

- [1] Sule L, Wardana ING, Soenoko R, Angled SW 2014 *Australian Journal of Basic and Applied Sciences* **8**(6) 186-192.
- [2] Reynolds BT 1983 *A history of the vertical water wheel*, The Johns Hopkins University Press, USA.

- [3] Kajinski B 1950 Low-power free-flow hydroelectric power plants, State Energy Publishing House, Moscow.
- [4] Kodirov D. Tursunov O 2019 *E3S Web of Conferences* **97** 05042.
- [5] Müller G, Wolter C 2004 *Proc. ICE Eng. Sustainability* **157** 203 – 212.
- [6] Kodirov D. Tursunov O. Parpieva S. Toshpulatov N. Kubyashev K. Davirov A. Klichov O 2019 *E3S Web of Conferences* **135** 01036.
- [7] Yassi Y 2013 *Iranian Journal of Mechanical Engineering* **14**(1) 33-47.
- [8] Yurenkov VN et al 2006 *Journal of AltGTU named after II Polzunova* **2** 143-150.
- [9] Satibaldiev AB, Matisakov TK, Attokurov AK 2015 *Int. J. Applied and Basic Research* **6** 413-416.
- [10] Kodirov D. Tursunov O 2020 *IOP Conf. Ser.: Mater. Sci. Eng.* **883** 012085.
- [11] Di Baldassarre G, Montanari A 2009 *Hydrol. Earth Syst. Sci.* **13** 913–921.
- [12] Ibrahim GA, Che Haron CH, Azhari CH 2015 *The Online Journal on Power and Energy Engineering* **1** 62-66.
- [13] Ashkar F 1996 On the Statistical Frequency Analysis of Hydrological Extremes Proceedings of the *International Conference on Hydrology and Water Resources* eds Singh VP, Kumar B (Dordrecht: Springer) **16** 485-503.
- [14] Schnitzer V 2009 Micro hydro power, GTZ, Germany.