

Kinematics of Seed Seed Soil Softener Crushing Device Star

Duskulov AA¹ and Isakov Alijon A^{2*}

¹Associate Professor, "Tashkent institute of Irrigation and Agricultural mechanization engineers" National Research University, Uzbekistan.

²Associate Professor, Jizzakh Polytechnic Institute, Uzbekistan

***Corresponding Author:** Isakov Alijon A, Associate Professor; Jizzakh Polytechnic Institute, Uzbekistan.

Received: August 25, 2023; **Published:** August 30, 2023

Abstract

The article presents an analysis of the process of preparing the soil for sowing, and an improved design and technological scheme, devices and the principle of operation of a cotton seeder, which provides loosening of the soil and crushing of soil clods in the seed sowing zone with simultaneous sowing of seeds. Materials are also given for determining the speed of the sprocket of the cultivator-grinder of soil clods.

Keywords: soil; plough, softening; cutting; chiselling; disking; harrowing; seed rake; soil softener-cutting grinder; star; plowing; loosening; clod; chiseling; disking; harrowing; cotton seeder; soil cultivator-clod chopper; sprocket; tooth; soil particle; agrotechnical requirements

Introduction

One of the most important conditions for the growth, development and intended yield of agricultural crops is to ensure that the level of soil softening during the growing season meets agrotechnical requirements. Preparation of the soil in accordance with agrotechnical requirements has a positive effect on the biological, biochemical and physical-mechanical processes taking place in it and improves the heat-air exchange in the soil and the regime of plant nutrition.

One of the most energy-intensive and important technological operations in the cultivation of agricultural crops, and one of the factors that seriously affect the productivity of plants, is the operation of preparing the field for planting. Currently, the preparation of the cultivated area for planting is mainly carried out in two stages: in the fall, the cultivated areas are plowed, and in the spring, the soil of the cultivated area is prepared for planting. At the first stage, the land of the cultivated area is prepared for cultivation, fertilized and plowed. In the second stage, agrotechnical measures such as smoothing the unevenness created during plowing, raking, working with disc tools, harrowing, crushing, and harvesting are carried out. In this case, depending on the condition of the soil of the cultivated field, agrotechnic activities such as hoeing, disking, raking, and troweling are carried out two or three times. As a result, agricultural aggregates have to pass over the cultivated area many times for tillage. This results in excessive compaction of the treated soil, structural damage, and increased energy and fuel consumption. Improper or low-quality execution of other operations performed during the preparation of the soil for planting: turning the soil layer, softening the soil, grinding, mixing, compacting, leveling and other operations, leads to a decrease in the quality of agrotechnical methods, and ultimately to a decrease in crop yield.

Agricultural machines equipped with various working parts are used to prepare the soil of the crop field for sowing seeds, and as a result of the aggregates made of them passing over the surface of the crop field several times, all the necessary technological operations are performed. When preparing the soil for planting, the working parts of machines designed to perform different tasks affect the soil in different ways. Plow bodies shear, deform and push the soil layer to the side, while the working parts of the chisel cultivator, disk and toothed harrows soften the soil and partially grind the lumps, and the trowel and ground levelers partially compact and level the soil. The ability of such working parts to grind the soil is low. Therefore, the surface layer of the soil of cultivated fields prepared for planting seeds is loose and compacted. In the process of planting, the pieces in it interact with the seeder blade, some of them are crushed by the blade, and some of them are not sufficiently affected by the blade of the seeder and they do not disintegrate. Ekkichs will pass over them. Unbroken cuts prevent the drill blade from sinking to the specified depth, and as a result, it causes the soil to not get a suitable shape, the soil of the bottom and side walls of the drill is not compacted to the required level, the seeds are not planted to the same depth, and the seeds are not buried with the soil. Experiments show that in such a case, 40% or more of the seeds are not planted to the designated depth, but are planted relatively shallowly or are left on the surface of the earth [1].

This problem can be solved with the help of working parts, which have a combined effect on the soil and treat the soil in accordance with agrotechnical requirements. In the area prepared for planting, such working parts 12 cm should soften the soil of the seed planting zone of each row with a width of 14-15 cm and a depth of 8 cm, grind the pieces and make the soil soft, and at the same time plant seeds on it.

Research methods

In the course of research, general scientific methods of experiment, generalization, analysis, synthesis methods, basic laws and rules of agricultural mechanics, theoretical mechanics and higher mathematics were used.

Research results and their discussion

In order to fully implement the above-mentioned processes, i.e., the soil of the zone where seed is to be planted, the construction scheme of the seed drill was developed [9, 3, 4, 5, 6, 7].

This seeder (Fig. 1) consists of a frame 2 equipped with drive wheels 1, a plow 17, a star block 18, a column 19, a soil softener-shredder, a seed box 6, measuring 7 and nesting 16 devices, and a coulter 15 It consists of planting sections, hanger 9, adjusting screw 10, spring 13, shovel soil dumper 14 and compaction roller 11, drive transmission 3 consisting of stars, conical gears 4, and reducers 20. The working parts of the soil softener-shredder of the planter are driven by the power take-off shaft of the tractor, through the cardan shaft, and the working parts of the planting sections are driven by the drive wheel.

When the seeding unit moves, the blade of the soil softener-shredder, attached to the front axle of the seeder frame, penetrates 8-12 cm deep into the soil, cuts a 14-15 cm wide soil layer and lifts it up along its working surface. When the layer of soil moving along the working surface of the harrow reaches the gap between the rotating star block and the working surface of the harrow, the teeth of the stars sink into the soil layer to a depth of h , crush the soil and the lumps contained in it, and throw it to the back of the harrow, instead of the previously cut soil layer. The seeder slide of the planting section flattens and partially compacts the softened soil. The plow blade cuts the soil into a furrow, and the soil compactor compacts and compacts the bottom and side walls of the furrow, creating conditions for seeds to be placed at the same depth and order, and for moisture to flow from the capillary tubes in the soil. The disc of the metering device drops the seeds into the trough in the specified quantity and order. Komgich pulled soil over the seeds and buried them. The compaction roller compacts the two sides of the piled soil with a steeper slope.

Thus, the seed seeder equipped with a soil softener-cutter grinder softens the soil of the seed planting zone of each crop row in the field at a depth of 8-12 cm and a width of 14-15 cm. and ensures uniform planting and creates favorable conditions for lateral germination and development of seeds.

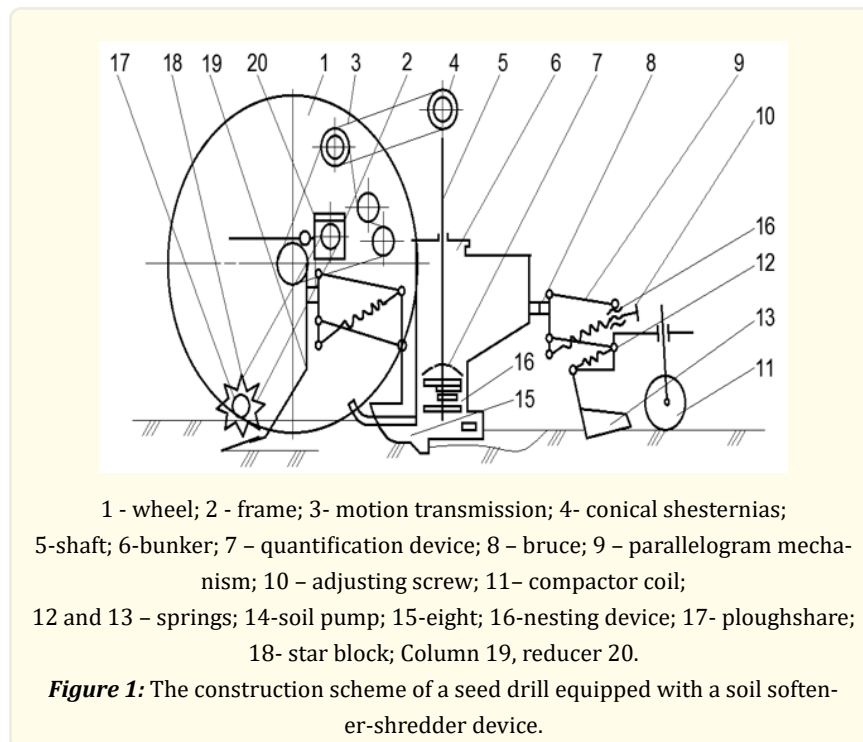

In this process, the teeth of the asterisks of the soil softener-shredder device unit of the seeder are complex: together with the planting unit, they move forward and rotate around their axis. Therefore, any point of the teeth of the block stars moves along the trajectory of an extended cycloid [8]. In this case, the maximum and minimum value of the absolute speed of the star teeth is determined on the basis of the condition that the crushed soil particles are ejected from the working surface of the device coulter under the influence of the block stars and do not interfere with their work by falling on the rear parts of the coulters.

The absolute speed of the teeth of the star block stars, the speed of the unit, the ground softener-cut grinding device depends on the geometric and kinematic parameters of the star block stars.

Using the diagram shown in Figure 2, the radius of the inner point (base) of the star tooth A is $OA = r$, ($OA = OS = r$ – the distance from the center of rotation of the star to the base of the tooth) and the outer point $OB = R$ ($OB = OD = R$ – the distance of the star the distance from the center of rotation to the tip of the tooth, that is, the radius of the star) and write the parametric equations of these points.

Parametric equation of point A:

$$\begin{aligned} X_A &= V_M t \cos \alpha + r \sin(\omega t + \beta) \\ Y_a &= r(\omega t + \beta) \end{aligned} \quad (1)$$

Parametric equation of point B:

$$\begin{aligned} X_B &= V_M t \cos \alpha + R \sin \omega t \\ Y_B &= R \cos \omega t \end{aligned} \quad (2)$$

where V_m is the speed of movement of the seed drill equipped with a soil softener-shredder device;

ω – angular speed of the star block of the soil softener-shredder;

t is the time when the star turns a certain angle.

The trajectory of movement of the tooth located after this tooth of the sprocket is the same as that of the tooth located in front of it, only $t_1 = \alpha_1 / Z$ after the passage of time (where Z is the number of teeth of the sprocket), it takes its position. This is the soil layer in $l = V_M \cos \alpha \cdot t_1$ time (t_1). moves to a distance. In it, the parametric equations of the points belonging to the second tooth of the asterisk are written as follows:

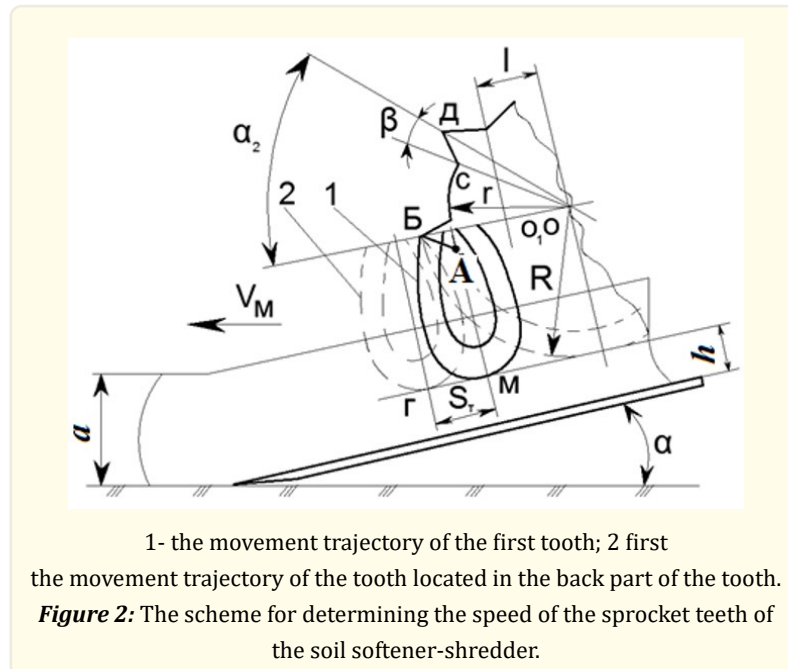

Parametric equation of point C

$$\begin{aligned} X_C &= V_M t \cos \alpha + r \sin(\omega t + \beta - \alpha_1) \\ Y_C &= r \cos(\omega t + \beta - \alpha_1) \end{aligned} \quad (3)$$

D point parametric equation:

$$\begin{aligned} X_D &= V_M \cos \alpha \cdot t + R \sin(\omega t - \alpha_1) \\ Y_D &= R \cos(\omega t - \alpha_1), \end{aligned} \quad (4)$$

where $-\beta$ the angle between the axis line of the star tooth and the line connecting the center of the star and the edge point of the tooth base.

The following general expression for the absolute speed of the side edge of the star tooth (AB or SD) at any time interval is (5).

$$V = \sqrt{\left(\frac{dx}{dt}\right)^2 + \left(\frac{dy}{dt}\right)^2}, \quad (5)$$

It can be determined using [2]. In it, the formula for determining the absolute speed of the base of the tooth of the seed drill, soil softener-shredder, that is, point A, will have the following form:

$$V_A = \sqrt{\left(\frac{dx_a}{dt}\right)^2 + \left(\frac{dy_a}{dt}\right)^2}, \quad (6)$$

(1) differential formula,

$$\frac{dx_A}{dt} = V_M \cos \alpha + r\omega \cos(\omega t + \beta)$$

and

$$\frac{dy_A}{dt} = -r\omega \sin(\omega t + \beta)$$

put them in the place of the limits of formula (6) and became the basis of the asterisk. We express the absolute speed of point A as follows.

$$V_A = \sqrt{(V_M \cos \alpha + r\omega \cos(\omega t + \beta))^2 + (-r\omega \sin(\omega t + \beta))^2} \quad (7)$$

After performing several arithmetic operations on the formula (7), the formula for determining the absolute speed of point A, which is the base of the star tooth, will have the following form:

$$V_A = \sqrt{r^2 \omega^2 + 2r\omega V_M \cos \alpha \cdot \cos(\omega t + \beta) + V_M^2 \cos^2 \alpha}, \quad (8)$$

By differentiating the expression (2), the absolute frequency of the point B of the star hole of the linear sieve coarser softener-cut grinding device,

$$\frac{dx_B}{dt} = V_M \cos \alpha + R\omega \cos \omega t$$

and

$$\frac{dy_B}{dt} = -R\omega \sin \omega t$$

taking them into account, we write the formula expressing the absolute frequency of the tip-B point of the star tooth.

$$V_B = \sqrt{(V_M \cos \alpha + R\omega \cos(\omega t + \beta))^2 + (-R\omega \sin(\omega t + \beta))^2}, \quad (9)$$

After performing several arithmetic operations on this formula (9), the formula for determining the absolute speed of the star tooth tip - B point will have the following form.

$$V_B = \sqrt{R^2 \omega^2 + 2R\omega V_M \cos \alpha \cdot \cos \omega t + V_M^2 \cos^2 \alpha}, \quad (10)$$

The absolute speed of the star tooth of the star block of the seeder soil softener-shredder device, $\dot{\theta}t = 2pk$, ($k = 0, 1.2$) will have a maximum or minimum value. Then from the formula (10), the maximum of the point B belongs to the star tooth.

$$V_{E\max} = R\omega + V_M \cos \alpha, \quad (11)$$

and minimal

$$V_{E\min} = R\omega - V_M \cos \alpha, \quad (12)$$

velocities, takes this form.

(11) and (12) by putting the radius of the star $R = 0.1$ m, the angular speed of $\omega = 16.7, 18.8$ and 21.9 s^{-1} and the speed of movement of the unit $V_M = 1.44$ and 1.77 m/s if calculated, we determine that the maximum value of the absolute speed of the star tooth is 3.09-3.96 m/s, and the minimum value is 0.1-0.42 m/s.

Thus, formulas (11) and (12) allow determining the maximum and minimum values of soil particles ejected from the back edge of the plow under the influence of the stars of the seed drill soil softener-shredder device, where the maximum speed of soil particles is 3.09-3.96 m/ externalizes s.

Conclusions

1. At the same time, the construction scheme of the seeder, which softens the soil of the seed planting zone to the level of agrotechnical requirements, grinds the pieces, and sows the seed, has been developed.
2. The unit of the soil softener-shredder device with the radius of the star $R = 0.1$ m has $\omega = 16.7, 18.8$ and 21.9 s^{-1} angular speed and planting unit $V_M = 1.44$ and 1.77 m/s when moving at high speed, the maximum speed of the soil particles ejected from the back edge of the plow of the device is equal to 3.09-3.96 m/s.

References

1. Baimakhanov K. "Improving the process of seeding and parameters of the runner coulter of a cotton seeder". Abstract dis. ... cand. tech. Sciences. Yangiyul (1987): 17.
2. Bat MI, Dzhangeldadze GYu and Kelzon AA. "Theoretical mechanics in examples and problems". M. Science 1 (1984): 502.
3. Duskulov A and Isakov A. "The effect of the frequency of rotations of the star block of the seed drill, the soil softener device, on the composition of the soil aggregate". Bulletin of Agrarian Science of Uzbekistan (2020): 2.
4. Duskulov A and Isakov A. "The influence of the width between the stars of the seed drill soil softener device on the soil aggregate composition". National Information Agency of Uzbekistan Uza. Department of Science. January (2020).
5. Duskulov A, Isakov A and Jalilov Z. "Methods of managing the agricultural background of cotton and technical means for their implementation". for taking part in the International Scientific Conference "Construction mechanics, hydraulics and water resources engineering" (2020).
6. Duskulov A and Isakov A. "About some results of research the cotton seedier devices". International journal of advanced research in science, engineering and technologist (2020).
7. Duskulov A and Isakov A. "Improving the design and technological work process of the seed drill". Ecologically clean resource-saving technologies of production, storage and processing of agricultural products. Republican scientific-practical conference. Tashkent (2009): 103-105.
8. Listopad GE., et al. "Agricultural and reclamation machines". M. "Colossus". 488-525.
9. Patent Rights. FAP 00473 "Equipment for seeding on ridges".

Volume 5 Issue 2 September 2023

© All rights are reserved by Isakov Alijon A., et al.