

электронное периодическое издание

ЭКОНОМИКА

и

социум

ISSN 2225-1545

№12(79)-2020



ЭЛЕКТРОННОЕ НАУЧНО-ПРАКТИЧЕСКОЕ
ПЕРИОДИЧЕСКОЕ ИЗДАНИЕ
«Экономика и социум»

<http://www.iupr.ru>

УДК 004.02:004.5:004.9

коммуникации
ББК 73+65.9+60.5

ISSN 2225-1545

Свидетельство о регистрации
средства массовой

Эл № ФС77-45777

от 07 июля 2011 г.

Редакционный совет:

*Зарайский А.А., доктор филологических наук, профессор,
Калимбетов Х.К., доктор экономических наук, доцент,
Смирнова Т.В., доктор социологических наук, профессор,
Федорова Ю.В., доктор экономических наук, профессор,
Постюшков А.В., доктор экономических наук, профессор,
Тягунова Л.А., кандидат философских наук, доцент*

Отв. ред. А.А. Зарайский

Выпуск №12(79) Часть 1. (декабрь, 2020). Сайт: <http://www.iupr.ru>

© Институт управления и социально-экономического развития, 2020

*Abdullayeva N.S.
teacher of department of languages
faculty of agrology and business
Andijan Branch of Tashkent State Agrarian University
Uzbekistan, Andijan*

THE USE OF AUTHENTIC VIDEO MATERIALS IN THE FORMATION OF STUDENTS' COMMUNICATIVE COMPETENCE IN NON-LANGUAGE HIGHER EDUCATION INSTITUTIONS

Abstract: In modern lingo didactics, there are many techniques and methods for the formation and improvement of communicative competence, while, due to the availability of digital materials and network technologies, the use of authentic video and audio materials becomes relevant.

Key words: formation, improvement, communicative competence, foreign languages, authentic video and audio materials.

There are various approaches to describing the structure and content of communicative competence. So, in one of the approaches, the following types of competencies are distinguished:

1. Linguistic (linguistic) competence - knowledge about the system of language, about the rules for the functioning of language units in speech and the ability to use this system to understand other people's thoughts and express their own judgments in oral and written form.

2. Speech competence includes knowledge about the ways of forming and formulating thoughts using language, as well as the ability to use language in speech. Some researchers also call this type of competence sociolinguistic, trying to emphasize the inherent ability of the owner of such competence to choose the necessary linguistic form and method of expression depending on the conditions of the speech act: the situation, communicative goals and the speaker's intentions.

3. Social competence is manifested in the desire and ability to enter into communication with other people, in the ability to navigate in a communication situation and build a statement in accordance with the speaker's communicative intention and the situation.

4. Sociocultural competence means that students know the national and cultural features of the social and speech behavior of native speakers their customs, etiquette, social stereotypes, history and cultures, as well as ways to use this knowledge in the process of communication.

5. Strategic (or compensatory) competence is a competence with the help of which a student can fill gaps in language knowledge, as well as speech and

social experience of communication in a foreign language environment. Possession of it makes it possible, for example, when reading, to guess about the meaning of unknown words, starting from the context, situation or topic; when using the dictionary, select the desired translation of the desired word from several options, as well as understand the meaning of the word by familiar morphemes, such as a root, prefix or suffix.

6. Discursive competence refers to the student's ability to use specific strategies for constructing and interpreting a text.

7. Subject competence is the ability to navigate in the content plan of communication in a certain area of human activity.

The very concept of authentic materials appeared in the methodology not so long ago, which is associated with the modern definition of the goals of teaching a foreign language. Authentic materials in this work are materials created by native speakers for native speakers for non-educational purposes.

Speaking about the advantages of using authentic videos in foreign language classes with students, first of all I would like to note their attractiveness for students: watching videos, both fictional and documentary, both short and full-length, is one of the favorite activities of young people at the present time.

The use of game videos in foreign language classes contributes to immersion in the natural cultural and linguistic environment in cases where students do not have the opportunity to do this directly by visiting the country of the target language.

Thanks to the use of authentic video materials in the classroom, several tasks are solved at once, associated with the development of various aspects of communicative competence:

1) language competence - the expansion of the lexical stock; development and improvement of listening skills (along with other types of speech activity); modeling of "immersion" in the language environment in educational conditions (mastering the intonation and tempo of lively conversational speech, acquaintance with the lively spoken language, idioms, phrasal verbs, dialects and socially limited vocabulary, with the peculiarities of the speech behavior of native speakers), that is, the film allows you to clearly represent the process of natural communication of native speakers.

8. In the linguistic aspect, authentic video materials are characterized by the originality of vocabulary: they contain many pronouns, particles, interjections, words with emotional connotations, phrases designed for the emergence of associative links, phraseological units, fashionable words; and the originality of the syntax: the brevity and lack of development of sentences, fragmentation, the presence of structure-dependent sentences used independently. During viewing, some language units are effectively assimilated due to associations arising in connection with certain characters or actors, their gestures, facial expressions, mood, appearance

2) linguistic and cultural competence - familiarity with regional information;

3) socio-cultural competence - familiarity with the cultural characteristics of a particular country; aesthetic development and expansion of the horizon of transnational ideas about beauty, the experience of interpersonal communication.

A feature film as a means of forming lingo-socio-cultural competence in foreign language classes at a non-linguistic university.

The main tasks in the development of communicative competence with the help of authentic videos include:

- expansion of vocabulary by presenting new lexical units or consolidating previously learned ones;
- presentation or consolidation of grammatical norms;
- work on pronunciation using emphasis on sounds, stresses, intonation based on imitation of actors' speech;
- formation and consolidation of listening and speaking, reading and writing skills;
- acquaintance with cross-cultural information (customs, traditions, norms of etiquette, etc.), mastering the national-cultural specifics of language communication;
- training the ability to determine the type of communicative situation, type of discourse, functional style of speech and select adequate communication methods.

The sociocultural background of authentic video materials is realized through a productive vocabulary, which includes the most communicatively significant lexical units common in typical communication situations, including evaluative vocabulary for expressing one's opinion, colloquial cliches, as well as words with a national and cultural component: background and non-equivalent vocabulary; the realities associated with rest, pastime, leisure, the realities of everyday life. They allow students to penetrate into another national culture, to master the everyday vocabulary of a native speaker.

Thus, the use of authentic videos can activate the development of all the main components of communicative competence. In our opinion, play video is especially effective, since it offers students additional emotional motivation to master the material and develop communication skills.

In pedagogy and methodology, there are many definitions of the concept of "communicative competence", however, most of them boil down to understanding communicative competence as the ability of students to carry out effective speech activity in accordance with the goals and situations of communication within a certain field of activity in compliance with the norms of social interaction inherent in a particular national culture. The formation of communicative competence occurs both in the process of natural communication and through specially organized training.

Working with authentic video material is divided in our program into three main stages: pre-viewing, while viewing and after-viewing, the latter being divided into control and creative stages. The main purpose of the exercises at the preview stage is to prepare the ground for further work, increase the level of motivation and interest of students, involve them in active activities, set up thinking on the desired topic, activate the existing knowledge on the topic, vocabulary and grammar in order to make the work on the next levels more simple and effective. The goal of the second stage is to assimilate basic and specific information, and the third is to control the understanding of the film and further work with video material to develop speaking and writing skills.

List of used literature:

1. Isupova M.M. The use of non-fiction authentic video materials in teaching a foreign language to students of non-linguistic universities // ISOM. 2016. No. 2-2. S. 148-153.
2. G.T. Qodirova. Linguistic and communicative competence in learning language. International conference., 2016, p.441.
3. N.A. Odilova., M.U. Irgashev. Information and communication technology in language learning. International conference., 2016, p.439.
4. Safonova V.V. Communicative competence: modern approaches to multilevel description for methodological purposes // What is argued about in language pedagogy. - М.: Evroshkola, 2004. --- 236 p.

*Abduraxmonova S.Sh.
2nd year master's degree student
in Preschool Education
Mamasoliyeva Sh.Kh.
2nd year master's degree student
in Preschool Education*

ASSIGNMENT OF PEOPLE'S FAIRY TALES AND THE FORMATION OF LIBRARY IN CHILDREN THROUGH MASS MEDIA

Abstract: This article highlights the role of fiction in educating children, inculcating universal values in folk tales through the media, and instilling a love of reading in children from an early age.

Keywords: Mass media, well-rounded personality, intelligence, technology, communication, artistic taste, value, humanity, creative thinking, reading, television.

Education is a complex process and plays an important role in our lives. It is the duty of all teachers to teach the young generation who are thirsty for knowledge, to teach them to find their place in life. We know from history that our ancestors were famous all over the world for their intelligence. Despite the fact that centuries have passed, their works are based on deep meaning and great ideas. These works will help educate our youth. "Education is for us a matter of life or death, salvation or destruction, happiness or disaster" A. Avloni. Indeed, the upbringing of the younger generation as morally, mentally, physically and spiritually well-rounded individuals has for centuries been a matter of serious debate and one of the most important issues among the advanced representatives of mankind. At a time when our country is developing rapidly, we can see progress in education. Today, changes in education are the foundation for future children. In the context of modern education, increasing the activity of children in the educational process requires the use of new innovative technologies. The purpose of any education is to develop students' knowledge and skills. This is an important factor in starting education from childhood. The development of children's folk tales through the media and television, depending on their age, allows them to quickly save information.

It is based on a more visual assimilation of information from fairy tales, which includes a variety of fairy tale books, children's magazines and instructional multimedia. It is difficult to impress today's children by simply reading. We need educators who think creatively in educating children, in inculcating universal values through fairy tales. First of all, every educator should be able to use information and communication technologies in their work, be able to work with the Internet, use the electronic library and its information in the field of education.

They should have enough information about which pages the information is relevant to the field of education, about the educational portals operating in the country.

The educator makes extensive use of the press and books, which are the main sources of education and upbringing of children. The book is recognized as a tool that responds to everything, according to the little ones. The purpose of children's books is to develop the emotions that nature has given them. The indirect effect of such books should be on the children's emotions, not their minds.

In fiction, fairy tales serve as a powerful, effective tool for educating children mentally, morally, and aesthetically, and have a tremendous impact on the development and enrichment of children's speech. Books play an important role in the formation of artistic taste. It is important that books are age-appropriate, not only in terms of subject and content, but also in the way they are told and decorated. Books for toddlers, especially 2-3 year olds, focus more on the effect of pictures than words. The child reinforces the content of the book in his memory by "reading" the pictures in the book to his friends, adults and puppets. The bright, beautiful pictures in the book nurture children's artistic taste

Today, in preschool educational institutions, it is important to acquaint children with works of art, to increase their love for fairy tales, in accordance with the requirements of the state and, of course, in the framework of 5 important initiatives put forward by the President. being carried out. The fourth initiative is aimed at raising the morale of young people, the organization of systematic work to promote reading among them. Fostering a love of books, independent thinking, and a broad outlook from the childhood of the next generation will lay a solid foundation for their well-being. It plays a key role in the formation of a perfect person. In the "State requirements for the development of primary and preschool children" it is the requirements for the development of reading skills of preschool children, the child is interested in books and reading, and the expected results are:

2-3-4 year olds have an understanding of books; asks adults to read a book; reads books appropriate for his age; identifies the relationship between pictures and words in a book; recognizes the familiar fairy-tale characters from the pictures. 4-5 year olds react to the story they are listening to and ask adults questions; can recite the main points of a work based on pictures; can name a work after listening to an excerpt from a work of art; knows the Mosshers by heart; uses the book carefully. 5-6 years old knows the first sound of a word; reads the book independently; distinguishes sounds; words can be articulated; rhymes words; uses dialogic form of speech, asks questions; memorizes and expresses poems; authors of favorite fiction, fairy tales and short stories and their names; correctly uses the tone of expression; Find words related to letters. 6-7 year olds tell other children the content of the book they remember; uses simple and complex sentences in speech; words can be divided into syllables; forms words from syllables using syllable cards; has an understanding of words, sounds,

syllables, speech; reads forewords, book titles, captions, etc .; knows the name of the genre of children's literature (fairy tale, poem, story); knows the names of famous writers and poets.

A number of reforms being carried out in our country today are aimed at further developing the educational process for the development of the next generation, who are well-rounded, physically and spiritually healthy, broad-minded and have high human qualities. The revival of our history, national traditions, values, the growing sense of identity among young people is worthy of the strength of the need for information, the rapid development of society, the age, the ability to express their knowledge among the world's youth. The role of the media and the press is invaluable.

In short, the inculcation of folk tales in the educational process serves the spiritual development of children through the media and enhances their knowledge and thinking.

References:

- 1 Sh. Mirziyoyev. Resolution "On measures to further improve the system of preschool education in 2017-2021." T., 2016.
- 2 Order of the Minister of Preschool Education of the Republic of Uzbekistan "On approval of the State requirements for the development of primary and preschool children of the Republic of Uzbekistan" 2019 June 18 B. 20
- 3 Kadyrova F.R., Toshpolatova Sh.Q., Kayumova N.M., Azamova M.N. "Preschool pedagogy" Tashkent: "Sparks of literature" - 2019. - P. 169
- 4 Sodiqova Sh. "Preschool pedagogy". "Garden of thinking" T.: 2013.
- 5 P. Yusupova. "Pedagogy of preschool education". Handbook 1993

Internet sites:

1. www.tdpu.uz.
2. www.pedagogue.uz.

*Abdusalomov U.S.
teacher of the Faculty of Military Education
Boltaboyev A.
teacher of the Faculty of Military Education
of Fergana State University
Uzbekistan, Fergana*

GENERAL CHARACTERISTICS OF THE MILITARY COMMITTEES OF THE ARMED FORCES OF THE REPUBLIC OF UZBEKISTAN

Annotation: This article informs about, the formation and unification of the military team, as well as the fact that each team which has its own characteristics, the great influence of the fighting spirit in the military team, and any difficulties encountered with this fighting mood victory, as well as the factors that determine the socio-psychological environment in the military community.

Keywords: military community, collective opinion, moral value, serviceman, mood, tradition, economics, politics, ideological reasons, spiritual.

In the process of formation and unification of the community, a common system of spiritual values is created. Spiritual values shape the mindset of the military community. A team opinion is a set of opinions that members have about an issue. Military activity is carried out in a military team, and in the process of this activity, the division of labor between the servicemen is of great importance. The public opinion in the units of the Armed Forces of our country is fully consistent with the public opinion in the whole society. This is a key factor in strong military discipline and high combat readiness. If servicemen have team-specific skills and competencies, interactions, as well as teamwork, will be effective, uninterrupted, and conflict-free. Each team will have its own structure. The position of the members in a certain position, the relationship between them, forms the structure of the team. In teams with a stable structure, the position of each serviceman is also strong and gives good results.

A team mood is a set of feelings that a team member has about an event. The mood of the team is very influential and it is the motivation for the behavior and activities of the military. Some types of team mood (passion, confidence in success, high mood) are a factor in its success, while others (bad mood, lack of self-confidence, boredom, sadness and dissatisfaction), on the contrary, reduce the team's chances.

In addition, military teams have their own traditions. It is a tradition to preserve a characteristic of a team over time. Events that occur in society in general, and in the community in particular, in interactions and relationships between people, often take the form of a custom or tradition. The mood in a military unit, its activities and lifestyle, the commander's leadership style, and the

specific behaviors of military personnel can also rise to the level of tradition. Traditions are universal, national, regional and collective. They serve as a kind of social "glue" in the team: it is the traditions that keep the team together. At the same time, it gives the team a sense of identity and charm. Traditions are divided into labor, sports, martial arts, and so on.

A unique socio-psychological environment also characterizes the community. Socio-psychological environment (microenvironment, moral environment) is a complex concept, which includes the feelings of each serviceman, the degree of satisfaction of their social needs (communication, mutual respect, friendship, abilities) level of performance, etc.), and the mood of the team. A set of emotions and experiences that occur in all or most members of a team at the same time is called team spirit. If the mood of an individual depends equally on physiological and other social factors, then the mood of the community is primarily the result of the whole system of social relations (economic, political, ideological, and spiritual). Social life is determined by the material and spiritual conditions of human life.

Mood is a moving element of psychology and changes very quickly. A person's mood can quickly spread to others and "nourish" them. This is where the socio-psychological law of imitation applies, according to which, along with the positive, the negative also spreads quickly (for example, bad behavior, stupid fashion etc.). Bad moods are common among military personnel. It has no ideological reasons, but psychological reasons. The best way to prevent negative moods is to introduce statutory requirements in the unit, properly organize service, work and rest, as well as provide comprehensive care for military personnel. It is important to regularly inform servicemen about the situation in our country and in the world. First, commanders need to have confidence and alertness in their work. They need to be able to detect and prevent in a timely manner the negative moods that have just emerged in one or more military personnel. The military traditions formed in the teams are a source of positive mood: military oath, military parade, weapons and military equipment inspection, evening visit, enlistment of young soldiers, celebrations, exchange of guards, handing over the battle flag to the military unit tribe

Another factor that determines the socio-psychological environment in a military community is reputation (prestige or prestige), which is a specific form of relationship. Reputation is the socio-psychological influence of one person (group) on another person (group). For example, the influence of a leader or commander on his subordinates, the teacher on his students, the team on the individual, and the influence of higher organizations on lower organizations. With the emergence of a group, a phenomenon of prestige also emerges and it becomes an integral part of interpersonal communication. The reputation of a unit commander is a key condition for success in strengthening military discipline among servicemen and in training and educating them. It is important to

remember that a reputable commander has more influence than a non-reputable commander does.

Nevertheless, a reputation can never be gained through violence. Reputation is the product of existing relationships in the community as well as the positive qualities of the individual. Reputation always reflects respect for that person, confidence in his strengths and abilities. Another important aspect of reputation is that without it, no organizational activity can be carried out in society and in a particular military unit.

Reputation has the power of persuasion. Having it can have a powerful effect on those around you. Confidence in a person of prestige in the team is the unifying factor of this team. Any team can have not one, but several reputable people: a commander, a good specialist, military activists, an athlete, and so on. There are also many such soldiers. The reputation of an ordinary serviceman is a measure of his high position among his colleagues, based on respect, experience, knowledge, skills, moral, psychological and physical qualities. However, it is unfortunate to note that we have become accustomed to understanding the role of adults or commanders in the concept of prestige in life. Such a one-sided view of prestige contradicts the principle of educating servicemen in the community. It is the privileged servicemen among the ordinary soldiers who have a great opportunity to train other members of the team. The presence of a large number of dignitaries in the military unit indicates the richness and diversity of the spiritual life of the community, its wide range of opportunities. It should also be noted that the presence of a large number of people with prestige in a community - a great influence - sometimes leads to the emergence of an unhealthy environment in this community - a small group of opposing parties can also cause As a result, the team is divided into small groups and weakened.

Discipline is also a specific socio-psychological phenomenon in military units, governed by general military rules and ethics, commands and instructions of commanders, social and public opinion, traditions, and prestige. Law and morality underlie any discipline, including military discipline. General military regulations govern military discipline, the relationship between servicemen, and how to act in certain situations that arise in the course of daily service activities.

The main conditions for a positive socio-psychological environment in the community are:

- Stable team structure;
- Psychological compatibility between personnel;
- Everyone works for the overall result;

Experience has shown that the main reason for military discipline violations is that military personnel are partially or completely unaware of general military regulations. That is why it is so important for soldiers and sergeants to know the military regulations. His methodology plays an important role in teaching military discipline. Regulation training usually begins with an officer telling a

story about them. He tells the young soldiers about the types of military regulations, their purpose, and their importance in combat training. Then it is time to study the individual articles and reinforce them with real-life examples. In addition, some officers go the wrong way in teaching the rules - they require the military to memorize certain articles or rules completely. This attitude leads to indifference to their duties and a weakening of their mental activity.

References:

1. M.Jorayev. Fundamentals of military pedagogy and psychology. Text of lectures. FSU, 2010
2. Sh.Tilavoldiyev, S.Kochkarov. Fundamentals of military patriotic education. Methodological manual. FSU, 2020
3. N.Boymurodov. Applied psychology. Study guide. Tashkent, 2008

*Achilova O.U.
Xorazm viloyati Qo'shko'pir tumani
1-maktab fizika fani o'qituvchisi*

**“FIZIKA FANIGA HISSA QO'SHGAN OLIMLAR”
MAVZUSIDA KONFERENSIYA DARSLARINI TASHKIL ETISH
METO'DIKASI**

Annotatsiya: Ushbu maqolada “Fizika faniga hissa qo'shgan olimlar ” mavzusida konferensiya darslarini tashkil etish meto'dikasi mavzusida yozilgan bo'lib, dars mashg'ulotlarini samarali tashkil etish va o'tkazishda zarur bo'ladigan nazariy ma'lumotlar keltirilgan.

Kalit so'zlar: sinfdan tashqari ishlarning mazmun mohiyati, sinfdan tashqari ishlarni tashkil etish metodikasi, kvant mexanikasining yaratilishiga asos slogan olimlar, statistik fizikaning rivojlanishiga hissa qo'shgan olimlar.

*Achilova O.U.
physics teacher
1-school*

**"SCIENTISTS WHO CONTRIBUTED TO THE SCIENCE OF
PHYSICS" METHOD OF ORGANIZATION OF CONFERENCE
CLASSES ON THE TOPIC**

Abstarct: This article was written on the topic of "Scientists who have contributed to the science of physics" on the methodology of organizing conference lessons, and provides theoretical information that is necessary for the effective organization and conduct of lessons.

Keywords: The essence of the content of extracurricular activities, methods of organizing extracurricular activities, the basic slogan for the creation of quantum mechanics, scientists who have contributed to the development of statistical physics.

O'quvchilarni mehnatga ongli munosabatda bo'lish ruhida tarbiyalash ta'lim-tarbiya jarayonining vazifalaridan biridir. Bu masalani hal etishda sinfdan tashqari ishlarning ahamiyati muhimdir. Sinfdan tashqari mashg'ulotlar davomida uyushtiriladigan tajriba va kuzatishlar umumiy mehnat va amaliy ko'nikmalar hosil qilishda katta imkoniyatga ega. O'quvchilarni vatanparvarlik va baynalminallik ruhida tarbiyalash borasida ham fizikadan uyushtirilgan sinfdan tashqari ishlar katta imkoniyatga ega. Buyuk mutafakkirlarimizdan Ibn-Sino, Beruniy, Ulug'bek va boshqalarning qilgan ishlarini, ularning hayotlaridan lavhalarni yoki bo'lmasa XX asrda fizika sohasida U.Aripov, S.Azimov,

R.Bekjonov va boshqa vatanimiz olimlari qilgan ishlarini sinfdan tashqari o`tkaziladigan tadbirlarda ko`rsatish, devoriy gazetalarda ma`lumotlar berish yaxshi samara beradi. Shuningdek, keyingi paytlarda vatanimiz fizik olimlari boshqa mamlakatlar olimlari bilan hamkorlikda ishlab erishayotgan yutuqlari haqida, bu yutuqlar turli millat vakillarining hamkorlikdagi ishining natijalari ekanligini o`tkaziladigan tadbirlar orqali o`quvchilar ongiga yetkaza olsak maqsadga erishgan bo`lamiz.

Maktablarda tashkil etiladigan hamda o`tkaziladigan sinfdan tashqari mashg`ulotlar o`quvchilarning umumiy ta`lim va politexnik saviyasini oshirish, vatanparvarlik ruhida tarbiyalash, ijodiy tashabbuskorligini oshirish uchun keng imkoniyatlar ochib beradi. Shuningdek, o`quvchilarning fizika darsiga bo`lgan qiziqishini orttiradi. Sinfdan tashqari ishlar o`quvchilarning qiziqishlarini hisobga olgan holda tashkil qilinadi. Fizikadan tashkil etiladigan sinfdan tashqari ishlardan biri to`garaklardir. Fizikadan to`garaklarni nafaqat maktabda, shuningdek akademiklitsey, kasb-hunarkollejlarida ham tashkil etilsa, nurustiga a`lonur bo`ladi. To`garak – bu sinfdan tashqari ishning muntazam shaklidir. Unda avvaldan tayyorlangan dastura sosida o`quvchilar qo`shimcha ma`lumotlar to`plamini oladilar, mavjud bilim va ko`nikmalarini chuqurlashtiradilar, hamda mustahkamlaydilar. Fizika to`garaklari tartibli ravishda o`tkaziladigan mashg`ulot hisoblanadi. To`garak a`zolari o`zgarmas bo`lib, to`garak a`zolarining umumiy majlislarida qabul qilingan dastur va jadval bo`yicha ishlaydi. O`qituvchiga darsga nisbatan sinfdan tashqari mashg`ulotni o`tkazish qiyinroq sinfdan tashqari ish o`qituvchidan katta ijodiy tashabbuskorlikni va amaliy tayyorgarlikni talab qiladi. Fizika o`qitishdagi ilg`or metodlar, yangiliklar sinfdan tashqari mashg`ulotlarda paydo bo`lgani tasodifiy emas. Fizikadan o`tkaziladigan to`garak ishining eng qimmatlisi shuki, bunda o`quvchilar o`z bilimlarini amalda qo`llashni o`rganadilar, hayotga ishlab chiqarish mehnatida ishtirok etishga tayyorlanadilar. Zamonaviy fizika bir-biri bilan o`zaro bog`liq bo`lgan mexanika va akustika, molekulyar fizika, elektr, magnetizm, optika, atom va yadro fizikasi kabi bo`limlarni o`z ichiga oladi. Fizikaning rivojlanishi hamma vaqt boshqa tabiiy fanlar bilan chambarchas bog`liq bo`lib kelgan. Uning rivojlanishi biofizika, kimyoviyfizika, astrofizika, geofizika va boshqa fanlar yaratilishiga olib keldi. Elektronmikroskop rentgsnostruktura analiz qurilma sharidan foydalanish biologiya va kimyoda molekula hamda hujayralarni vizual kuzatish. Kristollarning tuzilishi, murakkab biologik sisgematarni o`rganishda qimmatbaho ma`lumotlarni olishga yordam berdi. Hozirgi kunda Respublikamiz Fanlar akademiyasi qoshidagi fizika-texnika ilmiy tadqiqot instituti, Yadro fizikasi instituti, U. O. Orifov nomidagi Elektronika ilmiy tadqiqot instituti, boshqa qator ilmiy tekshirish institutlari va oliygohlarda fizikaning turli muammolarini hal qilishga oid ilmiy ishlar olibborilmoqda. O`zbek olimlari fizikaga oid darsliklar, ilmiy ommabop asarlar, atamalar lug`ati va boshqa adabiyotlar yaratdilar. Respublikamizda fizikafani rivojlantirishda U. O. Orifov, S. A. Azimov, S. U. Umarov, G`. E. Umarov, M. S. Saidov, M. M. Mo`minov,

R. X. Mallin, A. Q. Otaxo`jayev. R. B. Bekjonov va boshqa olimlarning xizmatlari katta. Molekulyar fizika – fizikaning turli agregat xolatlardagi jismlarning fizik xossalarini ularning molekulyar tuzilishlari asosida qarab chiqiladigan bo`limidir.

Molekulyar fizika jismni tashkil qilgan atomlar, molekulalar va ionlar xarakati va o`zaro tasirini o`rganish bilan bog`langan. Moddaning tuzilishi xaqidagi dastlabki tasavvurlar qadim zamonlardayoq paydo bo`lgan edi. Qadimgi grek faylasuflari bundan ikki ming yil oldin olamdagi xamma narsa bo`linmaydigan juda kichik zarra – atomlardan tashkil topgan deb tasavvur qilgan edilar. Grek olimi Demokrit (E. A 460 – 370 yillar) quyidagicha yozadi: “xamma narsa atomlardan tashkil topgan ... narsalar bir – biridan o`zlarini tashkil qilgan atomlar, ularning tartibi va vaziyatlari bilan farq qiladi ...”. Qadimgi atomislarning moddaning tuzilishi xaqidagi tasavvurlari faqatgina faraziy tusga ega ekanligini xisobga olish kerak. O`rta asrlarda atomistik talimotning tarafdorlari davlat tomonidan ta`qib ostiga olingan, chunki ularning bu talimoti jismlarning xossalarini tabiiy sabablari bilan tushuntirib odamlarning yaratuvchisiga xudoga bo`lgan etiqodini yo`qotadi, deb o`ylaganlar – 1026 yilda Fransiya oliy sudi atomistik talimotni tarqatishni o`lim jazosiga maxkum etish xavfi ostida taqiqlab qo`ydi. O`rta asrda atomistik gipoteza cherkov taqibi ostida unutildi. Faqatgina XVII asrda I. Nyuton molekulalar fazoda bo`sh joyni to`ldirishga intilishi xaqidagi tasavvurdan kelib chiqqan xolda gazlarning kengayishini tushuntirib berishga xarakat qildi. XVIII asrda molekulyar kinetik nazariyaning jonkuyar tarafdori va targ`ibotchisi M.B. Lomonosov edi.

1738 yilda molekulyar nuqtai nazaridan gazlar bosimini tushuntirish uchun miqdoriy xisoblashlarni qo`llagan birinchi olimlardan biri peterburg fanlar akademiyasining azosi D. Bernulli edi. Fizikada molekulyar nazariyaning qat`iy ilmiy rivojlanishi taxminan XIX asrning ikkinchi yarmida boshlandi. Nemis fizigi R. Klauzius, ingliz fizigi J. Maksvell va Avstriya fizigi L. Bolsman atom – molekulyar nazariyaga asos soldilar. Biroq, atom – molekulyar nazariya mislsiz ilmiy natijalariga qaramasdan bir qator yirik olimlar tomonidan qattiq qarshilikka uchradi. E. Max va B. Ostvald kabi mashxur fiziklar XIX asr oxiri XX-asr boshida atomning mavjudligini inkor etdilar.

XX asr boshida atom – molekulyar nazariyaning ishlanmasi ustida va uning tajribada tasdiqlanishida A.Eynshteyn, J. Perren, O.Shtern va boshqalar kabi mashxur fiziklar ish olib bordilar. Ular tomonidan molekulalarning real mavjudligini rad qilib bo`lmaydigan isbotlarigina olingan bo`lmay, balki ularning o`zaro tasiri va xarakatining qat`iy nazariyasi – molekulyar –kinetik nazariya (MKN) yaratildi.

O`quvchilarni fizika faniga qiziqtirish, bu fanni o`qitish sifat va samaradorligini oshirishda zamonaviy axborot va pedagogik texnologiyalaridann foydalanish qo`l keladi. Ular yordamida fizika fanidan o`quv eksprementlari, namoyish tajribalar, amaliy mashgulotlarni talab darajasida o`tkazish mumkin. O`quvchilarga faqat murakkab nazariy bilimlar berish emas, balki ularni yangi

pedagogik va axborot texnologiyalaridan foydalanib, zarur o'quv materiallari asosida o'qitish, ularning mustaqil bilim olishini tashkil etish kerak. Biz yuqorida aytganimizdek, o'quvchilar va boshqa qatnashchilar xotirasida uzoq vaqt saqlab qolishlari uchun ma`ruzalar 5–6 minut atrofida bo`lib, savollar ham qiziqarli, aniq bo`lsa, o'quvchilar zerikib qolmaydi. Savollarni ham sharoitga qarab ko`paytirish yoki kamaytirish mumkin. Maktablarda tashkil etilgan bunday to`garak va bahs kechalari o'quvchilar qalbida Vatanimizning fan va texnika sohasida erishgan yutuqlaridan faxrlanish hissini uyg`otadi. O'quvchilar to`garakda va bahs kechasida respublikamiz olimlari, injener-texniklari erishgan va qo`lga kiritgan yutuqlari bilan tanishadi.

Foydalanilgan adabiyotlar:

1. Kudryavsev P.S, Краткий курс истории физики, Moskva, 1974
2. M.N.Rahmatov, Vatanimiz fiziklari, Toshkent, 1983
3. M.Ahadova, O`rta Osiyolik mashhur olimlar va ularning matematikaga doyr ishlari, Toshkent, 1983
4. Классическая наука Средней Азии и современная мировая цивилизация, Toshkent, 2000.

*Ahmadjonova Sh.N.
teacher of department of foreign languages
faculty of agro engineering and hydro melioration
Andijan Institute of Agriculture and Agro technologies
Uzbekistan, Andijan*

THE USAGE OF INTERNET TECHNOLOGIES FOR EFFECTIVE FL ACQUISITION

Abstract: The article analyze the opportunities and affectivity of using Internet and its tools such as Web application - social networking/blogging. This research work is modern and convenient for FL learners because Internet application deals with innovative technologies, which are used nowadays in a learning process. The ability of the individual users to collaborate, create, and share content with other users may prove especially useful for learning languages. Social networks have generally been used informally for non-educational social interaction purposes.

Keywords: internet, FL, online, site, network, motivation, communicative approach, linguistic abilities.

The growth in global computer networks has spurred a massive increase in online foreign language learning. Far beyond earlier stand-alone tutorial applications, the interactive abilities of computer-mediated communication tools has prompted the study of language learning in text-based chat, massively multiple online gaming and mobile devices. In this work we investigate the use of social networking sites to learn a foreign language and the way they are used in learning languages.

In modern society, due to the growing power of globalization, foreign languages are becoming increasingly important. Knowledge of foreign languages is a prerequisite for any specialist qualifications. Learning foreign languages allows a person to expand their communication capabilities, vision, improve the level of culture. English is still leading, which is associated with the creation of the world economic, informational, cultural space.

According to the need to study the question of how to teach the language, what methods to use, how best to organize the learning process it is necessary to carefully examine the process of learning a foreign language, to identify the particular social and biological factors that influence this process, and to establish similarities or differences in the study of a foreign language and mother tongue, to compare the in vivo study and intentional learning. All this is the subject of research for many years and we can highlight the following points. To successfully mastering a foreign language prerequisites are:

- ✓ motivation to learn;
- ✓ linguistic abilities, socio-cultural, intercultural competence, background knowledge;
- ✓ linguistic environment, providing an opportunity to acquire and use knowledge.

New technologies offer great opportunities, provide tangible support, optimize the learning process. It is therefore necessary to turn to the experience of using electronic resources, multimedia abroad, to summarize the experience. Purposeful and systematic process of language acquisition should be based on the communicative approach, the form of the language person capable of cross-cultural interaction, must develop language skills, i. e. ability to fluently, spontaneously and correctly express thoughts in a foreign language.

Foreign languages facilitate international communication, display them on a qualitative level, promote economic development, cultural cross-fertilization, forming a tolerant attitude. Cross-cultural society needs a knowledge of languages and their teaching methods, need to continuously improve the knowledge, skills, competence program. Cross-cultural societies are products of globalization and internalization process.

As we know one of the best ways to learn another language is through practice. The best form of practice is a dialog with someone that is very proficient in the language the students are trying to learn. Part of their coursework will include practice chatting with other people on the site.

At the end of each unit, the student will work through a review of the material just covered in the form of an interesting test. The test does an excellent job of reinforcing what is already learned through word matches, and test translations of both written and spoken words and phrases.

Students practise communication skills on the site by recording their speech online. There are dialogs on the site. After having listened to the dialog they are to pronounce those phrases in green colour and send the recording to native speakers for feedback. Also there is opportunity to communicate with native speakers online via web cam or chats.

Social Learning - Language partners - search for people who are native speakers of the target language and practise through language exchange:

- Q & A - ask language related questions and get answers from the community;
- Groups - study together in groups.

Discuss topics surrounding culture, language acquisition, topics of interest. Work together to get help from people studying the same language.

Podcasts and videos - listen to or watch videos about different cultural and linguistic aspects to improve language ability.

I think that the Internet helps in teaching foreign languages and that the sites on the teaching and learning of foreign languages are used by teachers of foreign languages. The Internet has sample opportunities for teaching foreign languages. Teachers of foreign languages can create forums, blogs, sites for learning FL, teach FL via the Internet. Some of them created own accounts, where other people study FL and it is necessary for teachers FL to know how to use the Internet and how to work with the Internet in teaching FL. Social networking sites follow teachers FL to help students to study FL and nowadays these teachers understand that Internet can be useful in their professional activity. Teachers of foreign languages are the creators of the site on studying of foreign languages. These sites should be necessarily tasks, video lessons, audio lessons, books, dictionaries, translators, teaching to writing, grammar, speaking, listening, reading, pronunciation and vocabulary. Should also be diagrams, tables, forums, blogs, discussions, discussion on these sites. Do not forget about the charts, websites, manuals, references, anecdotes, jokes, stories and advices on studying foreign languages. You can add a conversation guides, poems, stories, memorizing words, tests, expressions, phrases, idioms, quotations, aphorisms, movies, cartoons, texts, dialogues, topics, monologues. Add programs, books, cards, games, crosswords articles and news. Unfortunately, many sites do not have the recommendations and tips for independent study of a foreign language. This is of course, wrong. Sites on studying of FL are different. But they are interesting for people. These sites are free and paid. But they should be free, because not all have the opportunity to pay for using these sites order to learn a foreign language. However, the Internet can not be and should not be the only source of teaching a foreign language. I advise you not to dwell only on the Internet in learning a foreign language. The more so that there are other means of teaching FL. Internet is just an additional tool of teaching FL, but there is availability of and relevance of learning materials, authentic materials. FL teacher can easily and quickly find a variety of materials on the Internet when they prepare materials for lessons. On Web sites for the study FL these same teachers write articles in a foreign language, conduct online lessons for other people. For example, for students. Teachers and students should follow netiquette rules. If teachers of foreign languages will not follow these rules, there will be no efficiency of using the Internet in teaching foreign languages.

List of used literature:

1. Levada Center. Innovative and entrepreneurial potential of society. - [Electronic resource] - Access mode. –URL: <https://docplayer.ru/30403016-Innovacionnyy-i-predprinimatelskiy-potencial-obshchestva-obsledovanie-levada-centra-po-zakazu-cmi.html> (Date of treatment 01/11/2019).
2. Umin E. A. Foreign - easy and with pleasure. - M.: Scarab, 1993.

3. Belyanin V.P. Neuro-linguistic programming and teaching foreign languages.
4. [Electronic document] / V. Belyanin // Moscow Psychological Journal. No. 1. 2004.
5. Egamberdiyeva D.U. The essence of the method of video-english. Conference materials. 2016.
6. Smelova L. Business course program for profile-oriented (economic) education of schoolchildren in grades 10-11 who study English. - [Electronic resource] - Access mode. –URL: <http://eng.1september.ru/article.php?ID=200700211> (Date of treatment 01/11/2019).

*Alimova X.T.
teacher of department of foreign languages
faculty of agro engineering and hydro melioration
Andijan Institute of Agriculture and Agro technologies
Uzbekistan, Andijan*

PROJECT METHOD AS A NEW METHOD OF TEACHING AND LEARNING ENGLISH

Abstract: The project methodology provides not only a solid assimilation of the educational material, but also the intellectual and moral development of students, their independence, goodwill towards the teacher and each other, sociability, and the desire to help others. The rivalry, arrogance, rudeness, and authoritarianism so often generated by traditional pedagogy are incompatible with this technology.

Key words: project methodology, development, innovative technologies, educational process, students, foreign languages, teacher.

In the 21st century, the intensification and modernization of education requires the introduction of such innovative technologies that pursue the goal of creative education of the individual in the intellectual and emotional dimensions. Such innovative technologies are: developmental learning, design, problem learning, level differentiation, test system, game learning, immersion in a foreign language culture, learning in cooperation, self-education and autonomy, integration. With this target setting, cognitive universal actions are one of the leading components of the educational standard. This is explained by the fact that one of the components of a child's mental development is his cognition, which implies the formation of a scientific picture of the world, the ability to manage his intellectual activity, mastery of methodology, strategies and methods of teaching, the development of representative, symbolic, logical, creative thinking, productive imagination, memory, attention, reflection.

The technology of problem-based learning involves the independent solution of cognitive and creative tasks through critical rethinking and augmentation of knowledge and skills; and allows you to realize the conditions for the formation of cognitive universal actions in students: creating an atmosphere of co-creation in communication, the inclusion of the child's emotional sphere, personal interest of the student, joint search for truth, self-assessment, self-correction, self-sufficiency.¹

In the process of “learning – teaching” there is a constant interaction between teacher and students. Each of the students carries out the teaching, which

¹ Irgashev M.U. Information Technology In The Process Of Learning A Foreign Language In A Non-Linguistic University//Economy And Society. № 6(73) -S.: 2020.

has a pronounced personal coloring, in different ways: one cannot demonstrate the assimilation of knowledge, the other, on the basis of previous experience, on the contrary, shows phenomenal abilities, and the third has mastered a certain style of attitude to the subject and stubbornly “does not want” study. It is impossible to deny the personal perception (or not perception) of the teacher by the student and vice versa, which also affects the progress in learning.²

The project method is a way to achieve a didactic goal through a detailed development of a problem, which should end with a very real, tangible, practical result. The basis of the project method is learning in the course of drawing up and executing projects, that is, some educational tasks that students solve in their imagination or in practice and have specific goals.

In the pedagogical encyclopedia it is noted that “the project method is a learning system in which students acquire knowledge and skills in the process of planning and performing gradually more complicated practical tasks - projects”.

The project method originated in the 1920s. in agricultural schools in connection with the idea of a labor school developing there more and more broadly. In the USA, Great Britain, Belgium, Israel, Finland, Germany, Italy, Brazil, the Netherlands and many other countries, where the ideas of the humanistic approach to education by George Dewey, his project method was widely disseminated and gained great popularity due to the rational combination of theoretical knowledge and their practical application for solving specific problems of the surrounding reality in the joint activities of learners. “Everything that I learn, I know what I need it for and where and how I can apply this knowledge” - this is the main thesis of the modern understanding of the project method, which attracts many educational systems seeking to find a reasonable balance between academic knowledge and pragmatic skills.

Project learning was aimed at finding ways, ways of developing active independent thinking of the child, in order to teach him not only to memorize and reproduce the knowledge that the school gives, but also to be able to apply it in practice. The general principle, thus, on which the project method was based, was to establish a direct connection between the educational material and the life experience of students, in their active cognitive and creative joint activities in practical tasks (projects) while solving one common problem.

The project method reflects the basic principles of a personality-oriented approach, humanistic pedagogy, which are also declared as priorities in all regulatory documents.

Nowadays, the project method is used because it makes it possible to consider the problem in its development, using the latest pedagogical technologies.

The project method always presupposes a problem. The project method is always pragmatic in nature: it involves not a simple consideration, research of the

² N.A. Odilova. The role of The competency format for presenting the Results of professional education//Economy and society. № 6(73) -S.: 2020.

designated problem, not just a search for ways to solve it, but also the practical implementation of the results obtained in a particular product of activity.

The ratio of the problem and the practical implementation of the results obtained and the solution or consideration makes the project method so attractive for the education system.

Method is a didactic category. This is a set of techniques, operations of mastering a certain area of practical or theoretical knowledge, one or another activity. This is the way of cognition, the way of organizing the process of cognition, achieving the set didactic goal.

Instructional design is the process of working on an educational project, the process of achieving the intended result in the form of a specific "project".

By definition, a project is a collection of certain actions, documents, preliminary texts, an idea for creating a real object, subject, creating a different kind of theoretical product. It is always a creative activity.

The project method in school education is viewed as a kind of alternative to the classroom system. The student's modern project is a didactic means of enhancing cognitive activity, developing creativity and at the same time the formation of certain personal qualities.

The project method is a pedagogical technology focused not on the integration of actual knowledge, but on their application and acquisition of new ones. The active involvement of the student in the creation of certain projects gives him the opportunity to master new ways of human activity in the socio-cultural environment.

The project method is based on the development of cognitive and creative skills of students, the ability to independently design their knowledge, the ability to navigate in the information space, the development of critical thinking.

The project method is always focused on the independent activity of students - individual, pair, group, which students perform for a certain period of time. This approach is organically combined with the group approach to teaching.

The project method always presupposes the solution of some problem, which envisages, on the one hand, the use of various methods, on the other hand, the integration of knowledge, skills from various fields of science, technology, technology, and creative fields. Working according to the project method involves not only the presence and awareness of a problem, but also the process of its disclosure, solution, which includes clear planning of actions, the presence of a plan or hypothesis for solving this problem, a clear distribution of roles (if we mean group work), i.e. tasks for each participant, subject to close interaction.

The project method forms students' communication skills, a culture of communication, the ability to formulate thoughts in an accessible and concise manner, to tolerate the opinions of communication partners, to develop the ability to extract information from different sources and process it using modern computer technologies, creates a language environment that contributes to the emergence of natural needs in communication in a foreign language.

The project form of work is one of the most relevant technologies that allow students to apply the accumulated knowledge of the subject.

Students expand their horizons, the boundaries of language proficiency, gaining experience from its practical use, learn to listen to foreign language speech, understand and hear each other when defending projects

Person-centered learning by means of a foreign language presupposes, on the one hand, the use of educational communication, cooperation and active activity of the student in the classroom, and on the other hand, the teacher needs to find a way to “introduce a real foreign language into the class, include the student in real language communication, without leaving the classroom, simulate the real process of entering the culture in educational process.

References:

1. Irgashev M.U. Improving the quality of training of students with use of information technologies //Economy and society. № 6(73) -S.: 2020.
2. N.A. Odilova. The role of The competency format for presenting the Results of professional education//Economy and society. № 6(73) -S.: 2020.
3. Matyash N.V. Project method of teaching in the system of technological education // Pedagogy. - 2000. - No. 4.
4. Pavlenko I.N. The use of project methods in teaching older preschool children // Foreign languages at school. - 2003. - No. 5.

*Almatova N.A.
teacher of department of foreign languages
faculty of agro engineering and hydro melioration
Andijan Institute of Agriculture and Agro technologies
Uzbekistan, Andijan*

PSYCHOLOGICAL FEATURES OF VISUAL AIDS IN TEACHING ENGLISH

Abstract: In the article, advances in science and technology now allow schools and universities to widely use modern means of visual teaching. Visualization in teaching a foreign language is: filmstrip, film, computer, games, audio recording, video recording, tables, pictures, speech patterns, diagrams, cards, etc.

Key words: technology, process, information, science, computer, games, audio recording, teaching.

If you take a retrospective look at the history of the development of civilization, it is not difficult to establish that people have always resorted to the use of auxiliary means for the success of teaching the younger generation. So, for example, data from archaeological excavations indicate that in very distant times, parents taught their children to count with the help of multi-colored pebbles, animal bones and other objects. At a later time, as it became known from literary sources, our colleagues who lived in ancient society, when teaching literacy, used waxed tablets, on which they wrote with a pointed metal rod - a stylus. By the way, this word (stylo), meaning "eternal feather", has survived in modern French.

The significant progress of science and technology in the 19th century, the further development of the capitalist mode of production led to the industrial revolution, as a result of which many new technical devices and machines appear, including those designed to serve the sphere of human life. If you take a retrospective look at the history of the development of civilization, it is not difficult to establish that people have always resorted to the use of auxiliary means for the success of teaching the younger generation. So, for example, data from archaeological excavations indicate that in very distant times, parents taught their children to count with the help of multi-colored pebbles, animal bones and other objects. At a later time, as it became known from literary sources, our colleagues who lived in ancient society, when teaching literacy, used waxed tablets, on which they wrote with a pointed metal rod - a stylus. By the way, this word (stylo), meaning "eternal feather", has survived in modern French.

The significant progress of science and technology in the 19th century, the further development of the capitalist mode of production led to the industrial revolution, as a result of which many new technical devices and machines appear,

including those designed to serve the sphere of human life. If you take a retrospective look at the history of the development of civilization, it is not difficult to establish that people have always resorted to the use of auxiliary means for the success of teaching the younger generation. So, for example, data from archaeological excavations indicate that in very distant times, parents taught their children to count with the help of multi-colored pebbles, animal bones and other objects. At a later time, as it became known from literary sources, our colleagues who lived in ancient society, when teaching literacy, used waxed tablets, on which they wrote with a pointed metal rod - a stylus. By the way, this word (stylo), meaning "eternal feather", has survived in modern French.

The significant progress of science and technology in the 19th century, the further development of the capitalist mode of production led to the industrial revolution, as a result of which many new technical devices and machines appear, including those designed to serve the sphere of human life.³ The first technical means; training were light projection devices, which projected images applied to transparent glass, in a darkened room on a white wall or a special screen. A candle, a kerosene or an electric lamp could be used as a source of light. How much the demonstration of static images was a miraculous act for that time, can be judged by the name of the device itself. - "magic lantern" (laterna magica).

The history of more or less widespread use of technical means in teaching foreign languages begins in the first and second decades of our century, when the "miracle of the century" appeared - a gramophone record.

The development of radio engineering, the commissioning of broadcasting radio stations led to the fact that already in the 30s of this century, the radio centers of London and Berlin began broadcasting lessons, respectively, of English and German for students of foreign languages on their own. However, the imperfection of the detector radio receivers of that time, the low power of radio stations, which in this connection sent educational radio broadcasts over short distances, did not allow teaching foreign languages with the help of radio on a large scale.⁴

A little later, the world witnessed new outstanding inventions - first electromechanical, then optical sound recording on (film), and in the 40s-50s - magnetic sound recording, the use of which, according to the general opinion prevailing among many of our foreign colleagues, opened a completely new era in teaching languages in general and foreign languages in particular. Giving a more restrained and at the same time realistic assessment of this teaching tool, it should be noted that it, like other aids, has its strengths and weaknesses, and therefore its use should always be methodologically justified. At present, the technicalization of the educational process continues to intensify; vigorous

³ Usmonova Sh.R. Features of using information and communication technologies in English lessons //Economy And Society. № 6(73) -S.: 2020.

⁴ Irgashev M.U. Information Technology In The Process Of Learning A Foreign Language In A Non-Linguistic University//Economy And Society. № 6(73) -S.: 2020.

attempts are being made to significantly increase the efficiency of teaching by using teaching machines of various types thanks to the means of television, both broadcast and, in particular, closed-circuit television. The time is not far off when video recording will firmly enter the teaching and educational process in foreign languages as an auxiliary tool with great didactic and psychological capabilities, and in the future, the introduction of highly effective simulators that will be able to analyze the sounding speech and offer the student appropriate corrections.

Having considered in general terms the development of tendencies - more and more intensive use of auxiliary means in teaching foreign languages - let us dwell further on the very concept of auxiliary means ".

In determining this, it is necessary, first of all, to proceed from the very large range of available means, both non-technical and technical. In accordance with this, it is impossible to refer to auxiliary teaching aids only traditional means of visualization - tables, pictures, diagrams, etc., which, in fact, are not special for teaching foreign languages and therefore are widely used in the study of many other educational subjects. On the contrary, it is necessary to refer to the special means first of all those that show their specificity precisely in teaching languages. This refers to the means of auditory visualization, i.e. background materials of various types. Other technical devices can also be classified as auxiliary devices, including such complex ones as electronic classrooms, electronic computers, etc., if they are used in teaching a foreign language. Therefore, it is necessary to include all teaching instruments as auxiliary means, i.e. from handouts of didactic material (cards with letters, syllables, words, numbers, speech samples) to the most complex radio-electronic devices (phono halls, electronic classrooms, electronic computers).

If all the means of teaching foreign languages at our disposal are grouped on the basis of certain characteristics, then we can describe their classification, represented, as is often done, in various types. Due to the fact that assistive devices can have a wide variety of characteristics that are often not decisive (size, color, purposefulness, static, dynamism, with or without the presence of language material, with or without a "built-in" program of speech actions, etc.) etc.), then it seemed more appropriate to take as a classification basis the most general criteria in terms of content, one of which is the method of demonstration, due to the presence or absence of a technical device. Thus, based on this criterion, all training tools can be divided into non-technical and technical. But this classification is still too general, so it turned out to be necessary to determine the presence of a number of subtypes that would have methodological significance, which would ultimately contribute to an increase in the effectiveness of the educational process.

When learning a foreign language, the above feelings do not play a significant role, at least in the non-advanced stages of learning. Consequently, the dominant channels of the individual's sensory system in the process of mastering a foreign language remain two - auditory and visual, which in certain cases

function simultaneously. This gave us the basis to distribute the variety of teaching aids into the corresponding subgroups, depending on the channel of receipt of educational information.

List of references:

1. Usmonova Sh.R. Features of using information and communication technologies in English lessons //Economy And Society. № 6(73) -S.: 2020.
2. Irgashev M.U. Information Technology In The Process Of Learning A Foreign Language In A Non-Linguistic University//Economy And Society. № 6(73) -S.: 2020.
3. Tigrov SV Personality-oriented tasks in the process of forming the design skills of university students: dis. Cand. ped. sciences. Lipetsk, 2004., p. 13
4. Federal State educational standard of basic general education. Approved by order of the Ministry of Education and Science of the Russian Federation dated June 25, 2018 No. 01/1884 [Electronic resource]

*Amanov A.K.
PhD student
at Urgench State University
Scientific adviser: Atadjanov I.Sh., c.g.s.
associate professor
Urgench State University*

THE ROLE OF SPECIAL ECONOMIC ZONES IN THE ECONOMY: FOREIGN EXPERIENCE AND UZBEKISTAN

Abstract: This article discusses the history of the formation of special economic zones (hereinafter - SEZ) in the world and in our country, as well as political, legal and socio-economic relations in the process of their development. It is also noted that today the role of SEZs in the world economy is growing, they are organized in a wide range of areas, and the volume of production and services is constantly growing. This reveals that this modernizing form of the economy is considered a promising direction not only in the world, but also in Uzbekistan.

Key words: market segments, customs procedures, customs extraterritoriality, investment, free zone, high-tech free economic zone, "fish producer" free economic zone, tourist free economic zone, pharmaceutical free economic zone, agro-economic zone, technopark.

INTRODUCTION

International experience shows that the basis for the rapid formation of special economic zones (hereinafter referred to as SEZs) in the world is targeted investment in them. The large inflow of investments into SIZs is directly related to their attractiveness or the conditions created for investors there. Today, SEZs are playing an increasingly important role in the global economy as a highly productive producer and service provider.

Historically and legally, the term "special economic zones" refers to the existence of a customs extraterritorial regime (ie, a special customs regime) in a particular area. But if we talk about the current concept of "special economic zones", as a modern interpretation of economic relations, it embodies all the elements of the special legal regime, its socio-economic and legal-political aspects. In world practice, the terms "special economic zones" and "free economic zones" are not the same and reflect two different stages in the historical evolution of economic zones in the world.

MATERIALS AND METHODS

The issues of organization, development, management and attraction of foreign investments in various types of SEZs were discussed by a number of foreign scientists EFAvdokushin, V.D.Andrianov, V.I.Butikov, T.P.Danko, Y.S.

Druzik, V.I.Zimenkov, S.A.Rybakov, J.B.More , Studied by R.Kumari, G.Abuselidze, T.Farole, G.Akinsi and others.

At the same time, a group of economists and economic geographers of our country, including K.X.Abdurahmanov, A.M.Abdullaev, A.V.Vahobov, N.X.Khaydarov, D.G.Gozibekov, N.R.Kuzieva, SH.K.Dadabaev, G.G.Nazarova, X.X.Khalilov, S.S.Mirzalieva, S.F.Rahmonova, N.G.Karimov, N.N.Oblomurodov, M.A.Raimjanova, SH.I.Mustafakulov, B.B.Valiev, A.A.Ostonakulov, Sh.S.Juraev in the scientific works The essence of free economic zones, their organization foreign experience, theoretical and practical aspects of attracting foreign investment to the national economy through free economic zones, their future prospects have been scientifically studied.

The economic literature created by the above scholars gives different descriptions of free economic zones. In particular, the Russian economist V.D. Adrianov describes: "Free economic zones are part of the national territory and provide ample opportunities for solving economic problems." [6]

A.A. Ostanakulov also described the free economic zone as an area created for the use of the economy as a regional method of diversification and the introduction of modern technologies in the economic structure.

In accordance with the Law of the Republic of Uzbekistan "On Special Economic Zones", called "free zones" in foreign and domestic scientific literature and legislation, this concept was approved on February 17, 2020 in our country. May 19, 2020. "Special Economic Zones." Moreover, when the term "special economic zone" is used in this law, the concept of "free economic zone" is understood as one of its directions.

The Law of the Republic of Uzbekistan "On Special Economic Zones" defines SEZs as follows:

special economic zone - an area with special boundaries and a special legal regime for the rapid socio-economic development of the region in order to attract foreign investment and domestic investment, high technology and management experience [1].

SEZs maximize profits and reliability for investors as the most important factor influencing the movement of capital and the outflow of foreign capital to the SEZ. The territory of a special economic zone is not defined as a territory politically or geographically. It is part of an economic space that has a system of incentives and incentives for doing business.

According to the definition of the International Convention on the Simplification and Harmonization of Customs Procedures (Kyoto, May 18, 1973), a free zone is a part of the state territory where goods are considered as objects outside the national customs territory and they are ordinary customs control and not taxed. In general, a special economic zone is a part of a country with special business conditions for national and foreign populations. [4]

SEZs are an important institution of the world economy and, as a means of shaping the national economy, are a non-traditional form of participation in the

international division of labor for many countries. As mentioned above, SEZs are now well integrated into world economic practice and are an integral part of international economic relations. If the country's economic situation is not attractive to foreign investors, one way to attract them is to create SEZs with a number of benefits in the country. We can also know this by the countries that make them up and the total number of SIZs in them.

Currently, there are more than 6,000 SIZs in more than 170 countries. In Uzbekistan, for example, a number of SEZs have been established since independence, and many of them are still operating.

It should also be borne in mind that not all FEZs give only positive results. For example, Uzbekistan has faced some problems with the introduction of FEZ for the first time. These efforts began in the 1990s with the formation of a free economic zone in Samarkand specializing in tourism. In addition, these cases were repeated in "Jizzakh" (1996), "Samarkand" (1997), "Nukus" (1998). The reason for these problems is that forensics, forecasting, and the use of the institute's expertise have not been used by experts to study the problem and the possible adverse events. [3]

However, later Navoi FEZ, Angren SEZ and Jizzakh SEZ were established in the country with high potential and unique advantages.

The first free economic zone in the country is the Navoi free economic zone. The recent decree provides for the establishment of new high-tech production facilities in the economic zone, the rapid development of communications, road transport, social infrastructure and logistics services. [2]



Figure 1. The first free economic zones of Uzbekistan

Not all SEZs can be considered as the "locomotive" of regional economic growth and development. Examples include some SEZs and some farm SEZs. On this basis, it is important to assess the real importance of SEZs for the economy of the region in which they are located.

Currently, there are 26 SEZs of 7 types in Uzbekistan, 12 of which are high-tech free economic zones:

- | | |
|-------------------|---------------------|
| 1. FEZ «Navoi» | 7. FEZ «Hazorasp» |
| 2. FEZ «Angren» | 8. FEZ «Termez» |
| 3. FEZ «Jizzakh» | 9. «Namangan» EIZ |
| 4. FEZ «Urgut» | 10. FEZ «Chirakchi» |
| 5. FEZ «Gijduvon» | 11. FEZ «Nukus» |
| 6. FEZ «Qoqon» | 12. FEZ «Sirdaryo» |

There are also 7 pharmaceutical free economic zones:

1. FEZ « Zomin-farm »
2. FEZ « Kosonsoy-farm »
3. FEZ « Sirdaryo-farm »
4. FEZ « Boysun-farm »
5. FEZ « Bostanliq-farm »
6. FEZ « Parkent-farm »
7. FEZ « Andijan-farm »

(Nukus-farm free economic zone is now transformed into Nukus free economic zone).

There are also tourist SEZ “Charvak”, SEZ “Tashkent-sport”, “baliq ishlab chiqaruvchi” SEZ “Lower Chirchik”, agro-industrial zones “Bukhara” and “Koson” and technoparks “Almazor” and “Yashnaabad”.

SEZs are created to attract local and foreign capital, expand exports, increase foreign exchange earnings, introduce new technologies, improve the balance of payments, and ultimately form the national economy and bring it closer to the world economy.

DISCUSSIONS AND RESULTS

Attracting investment resources will have a positive impact on the overall development of the region. However, it is important to understand that foreign investment can have a contradictory effect on the region's economy.

The SIZs will accelerate the growth of the region, strengthen the regional economy through technological renewal of the industrial structure, or the formation of high-tech industries, as well as competitive pressure on domestic producers in relevant market segments.

Control over the activities of business entities in the SEZ is regulated by a special law, as well as: regulation of customs duties, taxation, administrative regime, licensing, visas, banking, property relations (land ownership in the SEZ law), providing guarantees for investors, and managing a private zone.

In this regard, as an important part in the development of an open economy, there is ample opportunity to further strengthen the flow of investment in the Uzbek economy, in particular, foreign investment, the establishment of free economic zones, which are actively developing in world practice. It is important

to study the experience of foreign countries in attracting foreign investment through free economic zones. [5]

Today, SIZs are faced with: creating the most modern infrastructure, reducing administrative barriers, optimal customs and tax regimes, regional specifics and preferences - this is the promotion of innovative developments, the involvement of high-tech enterprises focused on the processing industry and the creation of competitive products with a high share of value added, as well as the implementation of import substitution ideas, innovative technologies, high-tech industries and the creation of new products, although the existing SIZs are partial they are fulfilling these requirements. Of all the possible options for the introduction and formation of an innovative economy, it is desirable to create the most promising industrial and innovative technological zones.

CONCLUSION

Special economic zones created in Uzbekistan, as well as around the world, are:

- creation of new jobs as a result of inflow of domestic and foreign investments;
- further improvement of existing developed industries, as well as the development of lagging industries;
- increase the country's production capacity for export-oriented products and reduce the demand for imported products;
- further improvement of living standards, as well as the emergence of competition between existing enterprises;
- can lead to positive results, such as the absence of currency fluctuations.

This will lead to a comprehensive socio-economic development of the country's regions and, consequently, to an increase in the living standards of the population. Based on this situation, it is economically and socially important that the SEZs in Uzbekistan are the future, and that in the coming years in the regions of the country will be created new areas with such special privileges.

References:

1. O'RQ-604-sonli O'zbekiston Respublikasining "Maxsus iqtisodiy zonalar to'g'risida"gi Qonuni Toshkent. 2020-yil 17-fevral
2. Mirziyoyev Sh.M. Buyuk kelajagimizni mard va oliyjanob xalqimiz bilan birga quramiz. Toshkent. "O'zbekiston" 2017
3. Astanov SH.R. Erkin iqtisodiy zonalar mamlakat iqtisodiyotini rivojlantirish manbai sifatida Huquqiy tadqiqotlar jurnali 2017 № 6.
4. Елагина К.М. Повышение эффективности функционирования особых экономических зон: российский и зарубежный опыт. Казан-2017.
5. Karimqulov J.I. BRICS mamlakatlarida erkin iqtisodiy hududlar orqali xorijiy investitsiyalarni jalb etish mexanizmi. Xalqaro moliya va hisob" ilmiy elektron jurnali. № 2, aprel, 2019 yil 1
6. Адрианов В.Д. Специальные экономические зоны. Журнал «ЭКО» 1997, (№3), S: 42.

TEACHING ENGLISH TO BLIND STUDENTS

Annotation: Throughout the years that I taught English to the blind I had to answer many questions asked by people who had no experience dealing with the blind. Of all the subjects teaching English to the blind is the easiest. Having said so there are one or two things teachers who are not trained to teach the blind may need to know before they can be an effective teacher to a blind student.

Key words: Technological help, textbooks, blind students, experiences, exposure.

Understanding degrees of blindness

First and foremost the teachers have to understand the visual condition of their blind student. The teachers do not need to understand the medical implication of the blind student's blindness, just how much residual vision he or she has.

- Is he or she totally blind?
- Does he or she have some sight left that he or she may be able to read big print?
- Eighty percent of learning is through sight.

Whatever amount of residual vision that is left of a blind person should be utilised to the maximum. So students with partial vision should be encouraged to read big print books.

Understanding the background

The next thing to do is to learn the background of the student. How and when he or she became blind. If the blind student became blind when he or she was, for example, at the age of eight or nine, he or she has certain visual memory. He or she will conceive ideas and images differently from someone who was blind at birth.

Setting up a readers service When confronted with a totally blind student do not despair. Read teaching material to the blind student and get him or her to Braille the material before lessons. The problem of a shortage of material in Braille has always plagued teachers for the blind.

Textbooks could never be brailled in time for my blind students. I always had to cope with one chapter at a time. But from my experience I can say that setting up a readers service for the blind is never too difficult. Just spread the word that there is a need for a pool of volunteers to read books into tapes or to blind students and there will be many volunteers.

Technological help

Also, nowadays there is computer software that is able to download material and transcribe it into Braille dots. The machine for brailleing out the dots is quite expensive though. Not knowing Braille is the least problem of teachers who are not specially trained to teach the blind. Technology can overcome that problem. Blind students can be trained to use the computer. There is sound synthesis software such as text to speech and voice recognition that can be installed on the computer. This software varies in price, but there are a number of programs which can be downloaded for free.

In the classroom

When in the classroom the blind student cannot see the board so the teacher has to be more vocal and say out every word he or she puts on the board including direction of where the words are. For example, teaching the format of a letter say out, 'On the left hand corner of your page you write the address. The address of this college is number twenty-nine, Green Lane'. Remember the blind student cannot see the board but he or she can hear well. When plans or diagrams are used, you can emboss them for your students by sticking string to cardboard. Here teachers may have to use their ingenuity.

Reactions of other students

I also tell teachers that the blind students in the class should not disrupt the lessons too much, meaning that the teacher should carry on as usual except for slight adjustments. Having a blind student in the midst of sighted students brings out the best of the sighted students. I have seen many sighted students come forward willingly to help their blind classmates and they even take the blind students on outings around the town. Things generally work out fine. One of my blind students was the top student of the graduating class.

Teaching tips

- I have used talking books and taped dialogues for reading comprehension lessons.
- I use real objects in my lessons. I brought in kites when the reading passage was about kites.
- I took my students to the kitchen and we had a lesson on how to prepare sandwiches and how to make tea.
- I took my senior students to a lower court to record the proceeding of court cases. I was able to do all these things because there were usually only eight to nine students in a class.

Blind students may be visually impaired but their other senses are intact, so teachers of the blind should utilise the other senses. Learning a language is very much tied up with culture, exposure and experiences. Blind students may not be able to acquire exposure and experiences the same way as sighted students. So teachers of the blind may have to do a little more than other teachers. Bring experiences and exposure to the blind students.

Conclusion

Well, basically, a blind student is a student first and blind or visually impaired second. Like many others things, blind students learn the importance of colours through their association with the sighted. The approaches towards teaching English to blind students are the same. When a blind student is out in the sighted world studying side by side with sighted students he or she is usually able to adapt to his or her environment. All the teacher needs to do is talk to the blind student and ask him or her whether there is any special requirement.

Referens:

1. Anderson Th., Forrester K. Reading then Writing: From Source to Essay. –New York: McGraw-Hill Inc., 1992 –523 p.
2. Brumft C. Communicative Methodology in Language Teaching. –Cambridge University Press, 1992 –166 p.
3. Delahunty G., James C. Language, Grammar and Communication: A course for teachers of English. –New York: McGraw-Hill Inc., 1994.–442 p.

Baltabaev O.O.

PhD student

Nukus State Pedagogical Institute named after Ajiniyaz

Nukus, Uzbekistan

THE ETYMOLOGY OF THE TAKHTAKUPIR TOPONYMY

Annotation. This article studied the origin of the name of Takhtakupir district, located in the Republic of Karakalpakstan. The etymology of the toponymy has been studied from historical and other scientific sources. Every geographical name has its own history of origin. The place names are one of the unique monuments of the people, nations and peoples with an ancient history. Because they themselves represent a world of history and destiny.

Key words: Takhtakupir, toponymy, geographical name, etymology, hydronym, oykonym

Introduction. Geographical place names or toponymy (Greek: topos - place, onima - name) - this field is studied not only by geographers, but also by historians, philologists, cartographers, ethnographers. The toponyms of our country have both historical and modern features, the existence of a separate naming system. As we all know, most geographical names arise from the natural geographical features of a region. However, geographical place names can appear even if no geographical feature is reflected in them. This is why studying the etymology of geographical names gives us a lot of information.

The aim of the research. The history of the origin of any toponymy, its meaning and the etymology of which language it belongs to have long been of interest to many. The toponyms of our country, which have a centuries-old history, like all national toponyms, have been formed in harmony with the history, culture and way of life of our people during our long historical past. Toponyms of our country are also toponyms with a long history that require in-depth scientific research. The main purpose of our research is to analyze and study the etymology of the toponymy of Takhtakupir in the territory of the Republic of Karakalpakstan on the basis of scientific sources.

Methods. Toponyms are studied mainly in geography, linguistics, history. Therefore, many facts of toponymy can be correctly interpreted only when many materials with different content - geographical, linguistic and historical materials are involved. Geographers, linguists and historians such as H. Hasanov, K. Abdimuratov, S. Koraev, M. Mirakmalov, T. Nafasov, T. Enazarov, K. Seytniyazov, K. Hakimov conducted scientific research in the scientific study of toponyms of our country. We also studied their research methods in depth during our research and based their scientific views on our research. However, the

etymological method was widely used in writing this article. Etymology (Greek: etimon - truth, the original meaning of the word, logos - science) - the study of the origin of the word, its original true meaning.

Results and discussion. The toponymy of each historical period differs from the toponymy of other periods in terms of meaning and grammatical structure. Because a historical event that takes place in any territory is sealed in the form of geographical names. For this reason, the study of toponyms has been of interest to researchers in identifying four interrelated aspects, which include:

1. Date of origin of the place name;
2. Variable meanings of place names;
3. Geographical features of the place;
4. How the place name came to be and who gave it its name.

Geographical place names are of great social and political importance both internationally and nationally, as they carry national, cultural and historical information. This is why we gain so much information through the scientific study of geographical names. Takhtakupir is a district located in the North-East of the Republic of Karakalpakstan, in the North-West of the Kyzylkum desert and in the South-East of the dried-up Aral Sea. Takhtakupir district borders with the Republic of Kazakhstan in the North-East, Navoi region of the Republic of Uzbekistan in the East, Ellikkala and Beruni districts of the Republic in the South, Karauzyak and Muynak districts in the West. Land area is 21,12 thousand km². The population of the district is 40,200. Takhtakupir district was first formed on May 10, 1928. In 1963 it was united into Chimbay district and on December 29, 1965 it was again separated as Takhtakupir district. According to experts, the toponymy Takhtakupir appeared more than a century ago. The **Takhta** is the board, the **kupir** - it is a bridge, a device, built on the water, to pass from shore to shore. The history of the origin of the name is connected with the construction of the bridge from the board. A century ago, a branch of the Kuvonchjarma canal, which brought water to the present-day Takhtakupir district, was called Bosay. People on both sides of the river inhabited it. A bridge to the river was very necessary for the people of the two sides to come and go with each other, and the elders of the people, united and in consultation, embarked on this important and worthy work. Hojamet Bolis led the construction of the bridge. All the people came to the hashar. Craftsmen from Chimbay are brought to build the bridge, mainly the long trees of Qosbauli's son Qalimbetboy were used in the construction of the bridge. Construction of the bridge took place during the winter months. Because the main building material was made of wood (timber), the bridge came to be known as a wooden bridge - Takhtakupir. The bridge was built in 1904 (in some sources it was 1903. It is known that the construction of the bridge began in the winter of 1903 and was completed the next year).

Conclusion. From the etymology of the toponymy Takhtakupir we can see the unity of our people, their love of work. Despite the fact that the geographical name arose more than a century ago, the geographical name has not lost its

significance, meaning and content. Today, one of the most pressing issues facing us is the study of geographical names that have been preserved for many years, such as the toponymy Takhtakupir, and inculcate in the minds of the younger generation the unity and diligence of our people through such geographical names. Therefore, it is necessary to study the toponyms of our country, to conduct scientific etymological research on each toponymy.

References:

1. Abdiev A., Reymov A. Takhtakupir designation. Tashkent. Turon-Iqbol, 2019. (in Karakalpak)
2. Abdirahmanov A. Toponymy and etymology. – Almata. G'lim, 1975. (in Kazakh)
3. Ayimbetov H. Takhtakupir is on a great road. Nukus, Karakalpakstan, 2007. (in Karakalpak)
4. Ayimbetov N. Origin of the term Takhtakupir. "Takhtakupir tani" newspaper. №10-11(5955-5956). 14 April 2018. (in Karakalpak)
5. Enazarov T.J. Toponyms of Uzbekistan: lexical bases and ways of etymological research. Dissertation for the degree of Doctor of Philology. Tashkent, 2006. (in Uzbek)
6. Kunnazarov K. Cities and districts of Karakalpakstan. Nukus, Bilim, 2006. (in Karakalpak)
7. Pahratdinov K.A., Serikbaeva A.S. History of naming of Takhtakupir district. International scientific-practical conference "The future of technical and humanitarian science". 8 June 2018. (in Kazakh)
8. Seitniyazov K.M. Place names of the northern districts of the right bank of Karakalpakstan. Dissertation for PhD in Geography. Tashkent 1998. (in Russian)
9. Takhtakopir district passport. 2020. (in Karakalpak)

*Baxodirova Sh.B.
O‘zMU xorijiy filologiya fakulteti
lingvistika (o‘zbek tili) mutaxassisligi magistranti*

MAKTABGACHA TA'LIM JARAYONIDA BOLALAR OG'ZAKI NUTQINI TAKOMILLASHTIRISH

Annotatsiya: bolalarda nutqiy funksiyalarning o'zlashtirish jarayoni davri, avtonom nutqning paydo bo'lishi, tilning semantik tomonlarini rivojlantirish, bolalar nutqini o'stirishda turli metodlardan foydalanish;

Kalit so'lar: ijtimoiy vaziyat, avtonom nutq, emotsional kechinmalar, lingvistik kashfiyot, obyektiv faoliyat, folklor, ermak o'yinlar (testoplastika, qum o'yinlari, rasmi o'yinlar);

*Bahodirova Sh.B.
graduate student of the Faculty of Philology
of the National University of Uzbekistan in the field of linguistics*

IMPROVING THE ORAL SPEECH OF CHILDREN IN PRESCHOOL EDUCATION

Abstract: the period of the process of assimilation of speech functions in children, the emergence of autonomous speech, the development of semantic aspects of language, the use of various techniques in the development of children's speech;

Keywords: social situation, autonomous speech, emotional experiences, linguistic discovery, subject activity, folklore, fun games (testoplasty, sand games, games in pictures);

Ma'lumki, go'dak ijtimoiy hayotga kirib kelishi bilan uning nutqi ham jamiyatga moslashib boradi. Bolaning atrof-muhitga bo'lgan qiziqishini qondirish uning ijtimoiy muhit bilan yanada kengroq tanishishiga imkon beradi. Maktabgacha bo'lgan davrdagi yosh - bu bolani aqliy rivojlanishining o'ta muhim va mas'uliyatli davri hisoblanadi. Bu bola tomonidan dunyoni faol bilish davridir. Ushbu davrda bola yaqinda yurib, makonni o'rganishga harakat qiladi, unga endi joyida qolish qiyin - har qanday obyekt uni o'ziga tortayotgandek tuyuladi. Ushbu davrda bola va kattalar o'rtasidagi aloqa yanada kuchayadi.

Bola tomonidan nutqiy funksiyalarning o'zlashtirilishi jarayoni uning maktabgacha yosh davrida uch bosqichda amalga oshadi. *Birinchi bosqich* (tug'ilganidan boshlab 9 oylik davrigacha)da go'dak atrofidagi kattalarning nutqini tushunmaydi va o'zi ham so'zlay olmaydi. Biroq bu bosqichda kelajakdagi nutqni o'zlashtirishga zamin hozirlanadi. *Ikkinchi bosqich* (9 oydan 3

yoshgacha) nutqning shakllanishi bosqichi. Bu davrda bolalar kattalar tomonidan qo'llanadigan oddiy, sodda shakldagi so'zlarni tushunishga harakat qiladi, o'zi ham dastlabki so'zlarni talaffuz qila boshlaydi. *Uchinchi bosqich* 3 yoshdan 7 yoshgacha bo'lgan davrni o'z ichiga oladi. Bu bosqichda bola kundalik hayotda faol qo'llanadigan nutq birliklarini to'liq o'zlashtiradi va ulardan muloqot jarayonida keng foydalanadi.[1, 15-b]

Bugungi kunning asosiy o'rganilayotgan sohalaridan biri bu nutqning rivojlanishi.

R.S.Nemovning ta'kidlashicha, «taxminan uch yoshga to'lganida, bolaning xotirasi, idroki, tasavvur va e'tibori insoniy xususiyatlarga ega bo'la boshlaydi. Ammo asosiy narsa shundaki, bola ma'lum bir yoshda asosan uning keyingi xulq-atvori, intellektual va shaxsiy rivojlanishiga ta'sir qiladigan mahoratni egallaydi. Bu tilni tushunish va odamlar bilan muloqotda faol foydalanish qobiliyatidir».[3]

V. S. Muxinaning fikriga ko'ra, "bolaning kattalar bilan muloqot shakllarining obyektiv faoliyatni o'zlashtirishi bilan bog'liq holda yuz beradigan o'zgarishlari, uning kichik yoshda rivojlanishi uchun katta ahamiyatga ega".[2]

D. B. Elkoninning ta'kidlashicha, «xuddi obyekt harakati rivojlanib borgani kabi nutq ham shakllanadi. Kichik yoshdagi bola uchun so'z vosita bo'lib xizmat qiladi, uni boshqa vositalarga qaraganda tez-tez ishlatadi, shuning uchun nutqning intensiv rivojlanishi mavjud». [8, 277-b]

G.A.Uruntayeva so'zning kommunikativ funksiyasini shakllantirishning uch davrini ajratib ko'rsatdi:

1) Vaziyatning asosiy tarkibiy qismi obyektidir. Bola unga harakatni mimik va intonatsion-ekspressiv hissiy tarkibiy qismlar bilan hamrohlik qiladi, uning ma'nosi kattalarga ta'sir o'tkazishdir. Agar urinishlar muvaffaqiyatsiz bo'lsa, unda ular norozilik ifodasiga, yig'lashga aylanishi mumkin;

2) Voyaga yetgan kishi vaziyatning tarkibiy qismiga aylanadi. Bola ko'zlarini mavzudan kattalarga qaratadi va ikkinchisida to'xtaydi. Obyektga yetib borishga urinishlar imo-ishoralar bilan almashtiriladi. Bola kattalarning e'tiborini uning urinishlariga qaratishga intiladi;

3) Vaziyat markazi so'zga o'tkaziladi. Bola kattalarga qaraydi, artikulyatsiyaga diqqat bilan qaraydi. So'zni talaffuz qilish uchun birinchi urinishlar paydo bo'ladi, bola artikulyatsion-talaffuz tasviriga qaraydi. Yetarli bo'lmagan nutq testlari yo'qoladi va bola kerakli so'zni - obyekt nomini aytadi. Bunda kattalarning narsalarga nisbatan harakati nazarda tutiladi.[6, 89-b]

Shunday qilib, biz nutq paydo bo'lgan vaziyat bolaning kattalar bilan mavzuli hamkorligini anglatishi kerak degan xulosaga kelishimiz mumkin. Bunday hamkorlikda kattalar bola uchun nutq vazifasini qo'yadi, bu esa bolaning xatti-harakatlarini qayta qurishni talab qiladi: tushunish uchun bola to'liq aniq so'zni aytishi kerak. Bu shuni anglatadiki, bola kattalarga murojaat qilishi, u aytayotgan so'zni ta'kidlab, boshqalarga ta'sir qilish uchun ishlatishi kerak.

O'zbekiston Respublikasi tarbiyachi va psixologlarining yosh bolalarda og'zaki nutqni rivojlantirish bo'yicha psixologik-pedagogik tajribasini tahlil qilib,

biz shunday xulosaga keldikki, yurtimizning ayrim hududlarida o'rta va katta maktabgacha yoshdagi bolalarda nutqni rivojlantirishga ko'proq e'tibor qaratilmoqda. Keling, ushbu uslubiy ishlanmalarni ayrimlarini batafsil ko'rib chiqaylik:

Maktabgacha ta'lim tarbiyachisi (Surxondaryo viloyati, Termiz shahri) Eshqobilova Sohiba N., nutqning rivojlanishi bolaning hissiy taassurotsiz mumkin emasligini ta'kidlamoqda.

«Ona tili, milliy madaniyat tarixiy jihatdan bolaning hissiy qo'shilishlari, fikrlash va nutq qobiliyatlarini rivojlantirish uchun qulay muhit bo'lib kelgan. Qadim zamonlardan buyon o'zbek xalqiga bu sohada folklor yordamga keladi - bu xalq tomonidan jamoat tomonidan yaratilgan va uning ko'p asrlik tajribasi va dunyoqarashini aks ettiradigan folklor san'atining maxsus sohasi. Shu bilan birga, bolalar nutqini erta yoshda rivojlantirish uchun eng qulay manbalardan biri bu jumboqlar, maqollar, bolalar o'yinlari, qofiyalar, qo'shiqlar kabi kichik folklor shakllari ».

Eshqobilova Sohiba N., shuningdek, bolalarda o'z-o'ziga xizmat qilish ko'nikmalarini shakllantirishda va gigiyena ko'nikmalarini tarbiyalashda, atrofdagi dunyo va uning hodisalarini o'rganishda, bolalarda ijobiy his-tuyg'ularni yaratishda bolalar she'rlaridan foydalanadi.

Tarbiyachi ta'kidlaganidek: "Bolalar bog'chalari bilan ishlash faqat bolalar bog'chasi devorlari bilan chegaralanmasligi kerak. Bu tizimli bo'lishi kerak, shundagina u bolaning so'z boyligi va ijobiy his-tuyg'ularini rivojlantirishda ijobiy ta'lim natijalarini beradi".

Bolalar bog'chalari orqali bola atrofdagi dunyo bilan og'zaki tanishishga kirishadi, uzluksiz kognitiv faoliyat uchun asos yaratiladi. Barkamol avlod 269 MTM tarbiyachisi (Toshkent shahri, Olmazor tumani) Haydarova G.S., bolalarni folklorning kichik shakllari bilan tanishtirish, artikulyatsiya apparati harakatchanligini rivojlantirishga, nutqning talaffuz tomonlarini rivojlantirishga yordam beradi deb hisoblaydi. Artikulyatsiya apparati harakatchanligini rivojlantirish uchun darslar taqlidli, o'ynoqi xarakteriga ega bo'lishi kerak. Masalan, O'rmon orqasidan, tog'lar ortidan, qorbobo chana minib kelmoqda "Bolalar ertagini o'qiyotganda, men bolalarga tillarini chertib, otga o'xshab chayqalishni taklif qilaman tovushini artikulyatsiya qilishga tayyorgarlik ko'ramiz yoki, bo'ri va yettita bola ertagini aytib bergandan keyin men bolalarga bo'ri qanday uvillashini ko'rsatishni taklif qilaman (lablaringizni naychadek cho'zing va ovoz chiqaring (U-U-U)).

Bola hayotining uchinchi yilida uning muloqot doirasi kengayadi: bola nafaqat yaqin odamlari bilan, balki boshqa kattalar bilan, shuningdek bolalar bilan muloqotni boshlaydi. Ushbu davrda nutq ko'rsatmalarini bajarish qobiliyatining rivojlanishi sodir bo'ladi. Og'zaki ko'rsatmalar bolaning xatti-harakatlarini tartibga solishga yordam beradi. Og'zaki ko'rsatmalarni bajarayotganda bolaning xatti-harakatlari qabul qilingan vaziyat bilan emas, balki kattalarning so'zlari bilan belgilanadi.

“Ma’lumki, maktabgacha yosh davrida bolaning asosiy faoliyati o‘yin hisoblanadi. Shu sababli u muloqot jarayonidagi savol-javoblardan o‘yin sifatida foydalanishi ham mumkin. Biz bolalar nutqiga xos bunday xususiyatlarni tadqiq etish maqsadida Malika Abduxalilova (4 yosh)ga quyidagi savol bilan murojaat qildik:

-Nima uchun bugun bog‘chaga bormading?

-**O‘shanga. Siz o‘qishga bordizmi?**

-yo‘q.

-**Nimaga?**

-**O‘shanga.**

Ushbu holat bola uchun qiziqarli bo‘lib tuyulganligi boisu kulib yubordi. Oradan olti kun o‘tganidan so‘ng Malika bilan suhbatlashdik. U muloqot jarayonida berilgan barcha savollarga **o‘shanga**, -deb javob berdi.

O‘zbek bolalar nutqi ustida olib borilgan kuzatuv natijalariga tayanib shuni ham ta’kidlash joizki, ayrim hollarda “o‘shanga” so‘zi bolaning ruhiyatidagi salbiy o‘zgarishlar yoki “nima uchun?” degan savolga aniq javob topa olmaganligi tufayli vaziyatdan chiqishni yengillashtirish vositasi sifatida xizmat qiladi. Aslida bola javob berishning bu usulini kattalar nutqidan o‘zlashtiradi”. [1, 96-b]

Yosh bolalar bilan ishlashning eng samarali usuli bu folklorning kichik shakllaridan foydalanishdir. Bolalar bilan birgalikdagi mashg‘ulotlarda xalq o‘yinlaridan foydalanish, qo‘shiqlar ijro etish, jumlar ularga katta quvonch baxsh etadi.

Vizual usullar guruhiga kuzatishlar, ekskursiyalar, rasmlarni, illyustratsiyalarni, fotosuratlarini, o‘yinchoqlarni tomosha qilish kiradi.

Bolalar narsalar bilan o‘ynashadi, masalan, "Telefon" o‘yini, bola o‘yinchoq apparatlaridan foydalanganda, onasi, otasi yoki ertak qahramonlarini chaqira oladi. "Telefon" o‘yini bola nutqining rivojlanishini rag‘batlantiradi, o‘ziga bo‘lgan ishonchni shakllantiradi.

I.P.Pavlov, A.A.Leontyev kabi olimlar bolaning motor harakati qanchalik baland bo‘lsa, uning nutqi shunchalik rivojlanib borishini isbotladi. Nozik motorikani rivojlantirish uchun o‘yinlar va mashqlar bola nutqining rivojlanishini rag‘batlantiradi. Bolalarning nutqini faollashtirish uchun ishda samarali faoliyatdan (modellashtirish, chizish, loyihalash) foydalanish katta ahamiyatga ega.

Nutqni rivojlantirish zamonaviy maktabgacha ta’lim tizimining ustuvor yo‘nalishi hisoblanadi.

Psixologik va pedagogik adabiyotlarni tahlil qilish, O‘zbekiston Respublikasi tarbiyachilari va psixologlari tajribasini umumlashtirish bir qator xulosalarga imkon beradi:

1. Ushbu tadqiqot muammosi bo‘yicha tegishli adabiyotlarni o‘rganish yosh bolalar nutqi rivojlanishining mohiyati va xususiyatlarini aniqlashga imkon berdi. Nutqni o‘zlashtirish jarayoni bir necha bosqichlardan o‘tishini aniqladik:

1) Dastlabki bosqichda bolada nutq tovushlariga nisbatan barqaror selektiv munosabat shakllanadi va fonemik eshitish shakllanadi;

2) Nutq paydo bo'lish bosqichida nutqni intensiv tushunish, nutq uslublarini o'zlashtirish mavjud;

3) Og'zaki muloqot bosqichida bola ona tilining grammatik tuzilishini, uning so'z boyligini o'zlashtiradi.

Bolaning birinchi so'zlari yordam yoki talab bo'yicha talaffuz qilinadi, shuning uchun o'qituvchi yosh bolalar bilan ishlashda bolalar rivojlanishining yoshi va individual xususiyatlarini hisobga olishi muhimdir.

2. O'zbekiston Respublikasi MTM tarbiyachilari va bir qator olimlarning ish tajribalarini tahlil qilish va umumlashtirish asosida shuni ta'kidlash mumkinki, tarbiyachilar, psixologlar va logopedlarning aniq, kasbiy muvofiqlashtirilgan va o'ylangan ishi, to'g'ri tashkil etilgan rivojlanish muhiti, bolaga individual yondoshish va ota-onalar bilan hamkorlik yosh bolalarda nutqni muvaffaqiyatli rivojlantirish uchun zarur shart-sharoitlardir.

Nutqni rivojlantirish bo'yicha yosh bolalar bilan ishlashda tarbiyachilar quyidagi usullardan foydalanishlari maqsadga muvofiqdir:

1) O'yinlar o'ynash (mobil, didaktik);

2) Folklorning kichik shakllaridan foydalanish (bolalar o'yinlari, qo'shiqlar, hazillar, topishmoqlar, ertaklar, she'rlar);

3) Noan'anaviy usullar (testoplastika, qum terapiyasi, rasmi o'yinlar, mozaikalar).

Ushbu usullardan yosh bolalarda og'zaki nutqni rivojlantirish bo'yicha tarbiyachi va o'qituvchilarning ishlaridan foydalanish istalgan natijaga erishishga yordam beradi

Adabiyotlar:

1. Qurbonova M.A. "O'zbek bolalar nutqi leksikasining sotsiopsixolingvistik tadqiqi" –monografiya Toshkent; 2014-y;

2. Мухина В. С. Возрастная психология : феноменология развития, детство, отрочество : Учебник для студ. вузов. – 5-е изд., стереотип. – М. : Академия, 2000. – 456 с.

3. Немов Р. С. Психология : Учеб. для студентов высш. учеб. заведений : в 3 кн. Кн. 2. Психология образования. – 3-е изд. – М. : ВЛАДОС, 1997. – 608 с.

4. Обухова Л. Ф. Возрастная психологи : учебник для вузов. – М. : Высшее образование; МГППУ, 2009. – 460 с.

5. Смирнова Е. О. Детская психология : Учеб. для студ. высш. пед. учеб. заведений. – М. : ВЛАДОС, 2003. – 368 с.

6. Урунтаева Г. А. Дошкольная психология : учеб пособие для студ. сред. пед. учеб. заведений. – 5-е изд., стереотип. – М. : Академия, 2001. – 336 с.

7. Чумакова И. Развитие речи ребенка раннего возраста (1-3 года) // Дошкольное воспитание. – 2012. - № 12. – С. 67-71.

8. Эльконин Д. Б. Детская психология : учеб. пособие для студ. высш. учеб. заведений. – 3-е изд., стереотип. – М. : Академия, 2006. – 384 с.

STYLE AND STYLISTICS: FUNDAMENTALS

Abstract: Stylistics is a systematic way of exploring a literary text especially the language of a text and tries to explain how language creates meaning, style and certain effect. The study of stylistics is considered as one of the significant tools to analyze a literary piece from the point of view of language. There are a number of scholars who are engaged in the interpretation of different genres of literature such as prose, poetry, drama, short story and one-act-play with the help of Stylistics. The interpretation of poetry is possible with the help of some of the important terms in stylistics.

Keywords: style, stylistics, literature, classical, investigation, rhetoric, poetic.

According to Mikhail Bakhtin, “style enters as one element into generic unity of the utterance” [1: 64], and the study of styles of language may only be productive when their generic nature is taken into consideration. From this point of view, stylistics may be viewed as a discipline included into discourse genre studies. Therefore the object of stylistics is not only the regularity of the choice and use of language means, as Bakhtin saw it, but first of all it is the study of types of organization of speech production and its realization in a singular text or group of texts. In the present chapter of our study we are going to turn to the notions of style and stylistics as we believe that a brief acquaintance with these notions and their peculiarities will be helpful for the further analysis whose objectives were stated before.[1:121]

First of all, what is style? The term “*style*” is a polysemantic one. The Latin word “*stylus*” meant originally a style or writing instrument used by the ancients in writing on waxed tablets. Already in Classical Latin the meaning of the word was extended by the process of metonymy to signify the manner of expressing one's ideas in written or oral form. The word later acquired a further meaning, the distinctive or characteristic mode of presentation, construction or execution in any art, employment or product: *the fine arts, sport*, etc. A glance into a dictionary of present-day English will show that the word “*style*” is used in about half a dozen principal meanings : a way something is done, design of clothes/hair, being elegant, style of book/painting/building, use of language; etc. [2:1294] The definition of style as the ability to speak and write well, i.e. a practical or utilitarian approach to problems of linguistic and literary expression, has been especially widespread in English-speaking countries. Until about the

early 1950s the problems of what is today known as stylistics were dealt with in British and American textbooks under the heading of 'Good English' or 'Rhetoric'.

Stylistics is a branch of linguistics which investigates the entire system of expressive resources available in a particular language. It is a relatively new linguistic discipline. The word "*stylistics*" was firstly attested in the Oxford English Dictionary only in 1882, meaning the science of literary style, the study of stylistic features. However, the first reflections on style can be dated back to the ancient times. Ancient rhetoric and poetics, which are considered to be the predecessors of stylistics, treated style as a specific mode of expression, the proper adornment of thought. The orator or poet was expected to follow the norms of artful arrangement of words, to use model sentences and prescribed kinds of "figures" in order to achieve particular expressiveness. After the ancient period the normative approach dominated in style investigations. The first attempts to evaluate and interpret the expressive possibilities of a national language were done in "The philosophy of style" [1852] by G. Spenser, "Zur Stylistik" [1866] by H. Steinthal, "Из истории эпитета" [1895] by A.N. Veselovsky, "О преподавании отечественного языка" by F. Buslajev, "Из записок по теории ловесности" [1905] by O. Potebnya. In 1909 the Swiss linguist Charles Bally published his "Traité de stylistique française" ["French stylistics"] where he rejected the established normative approach to style and developed a linguistic stylistics.

According to Ch. Bally the subject of stylistics is everything emotional and expressive in language and in speech. As a separate linguistic discipline stylistics began to form only in the 20-30s of the XXth century. In modern linguistics the term stylistics is employed in a variety of senses. But in general stylistics is defined as a branch of linguistics which studies the principles and effect of choice and usage of different language elements for rendering thought and emotion under different conditions of communication [3:7].

The object of stylistic study is so varied and complex that it is difficult to give a simple and generally acceptable definition of style. In the course of the historical development of a language evolves various functional subsystems each of which is characterized by the predominant use of specific words and expressions, grammatical forms and constructions, and certain phonetic features. Such functional subsystems or linguistic styles are limited to definite spheres of human activity, e.g. one distinguishes the styles of scientific prose, official correspondence, journalism, poetry, informal conversation, etc. in English.[4:11]

A language style may be tentatively defined as a more-or-less coherent system, a subsystem (or microsystem) within a language, consisting of certain lexico-phraseological, grammatical and phonetic resources of that language which are used selectively and purposefully to express ideas in a given situation. The study of language styles is the concern of linguo-stylistics. Put in another way, linguo-stylistics is a branch of linguistics which deals with the expressive

and stylistic means of language, their relations to the idea or ideas expressed, and the classification and peculiarities of the existing styles of a language. Linguo-stylistics is an auxiliary (ancillary) discipline which attains its full purpose only when used as a tool to perfect the learner's knowledge of a foreign language or in analyzing a work of literature. The ultimate aim of any linguo-stylistic analysis is the all-round comprehension of written or spoken utterance. It should be pointed out that there is a considerable amount of overlap between linguo-stylistics and literary stylistic studies. The latter are concerned first and foremost with the manner in which an author or literary current tends to use the expressive resources of language to convey ideas. The emphasis here is on the study of how a given linguistic form serves to render the ideological, emotional and artistic content of a work of literature. Linguo-stylistics is interested primarily in the expressive devices of language from the linguistic aspect and helps to shed light on a number of linguistic problems, such as lexical and grammatical synonymity, the semantic structure of words and phrases, etc. Linguo-stylistics and literary stylistics complement each other and together they constitute what may be called general stylistics. Stylistic analysis explores the uniqueness of a text to point out which patterns of language are used particularly. It involves comparisons of the language of the text with the language used in conventional types of discourse. Stylistics also attempts to establish principles capable of explaining the particular choices made by individuals and social groups in their use of language, such as the production and reception of meaning, socialization, critical discourse analysis and literary criticism. Stylistics focuses on the expressive properties of linguistic units, their functioning and interaction in conveying ideas and emotions in a certain text or communicative context.

In conclusion, present-day stylistics studies have gradually taken a strict systematic character. Increasing interest is also apparent in the quantitative aspect, where statistical and numerical counts of word frequency, etc. And the use of electronic computers has given stylistics a more exact basis than hitherto. With the advent of large corpora of machine readable texts the outlook for computer-assisted stylistic analysis appears to be especially promising. Apart from the study of cases of disputed authorship, it is now becoming easier to undertake studies of the influence of one author on another. Although still somewhat inchoate and unorganized, linguo-stylistics is obviously a vigorous young discipline whose development in the coming decades has serious and far-reaching implications for the advance of linguistic science as a whole.

References:

1. Bakhtin M. Слово о романе. Retrieved June 12, 2013. http://www.umer.Info/BiliotekBuks/Literat/bahtin/slovr_om.php.
2. Hornby A.S. Oxford Advanced Learner's Dictionary of Current English 6th edition, Oxford University Press, 2000:

3. Арнольд И.В. Стилистика. Современный английский язык: Учебное пособие. – Москва: Флинта, Наука, 2002. – 384 с.
4. Lehtsalu U. , Liiv. G. . Mutt O, An introduction to the English Stylistics 1973 151p.
5. Prasannata Ramtirthe, Style and stylistics: an overview. Pune research world, an international journal of interdisciplinary studies, Vol-I issue 4, 2017.
6. Bakhtin M. Слово о романе. Retrieved June 12, 2013. http://www.umer.Info/BiliotekBuks/Literat/bahtin/slovr_om.php
7. Encyclopedia Britannica www.britannica.com.
8. The Burns Encyclopedia online <http://www.robertburns.org/encyclopedia>.

Bobobekova J.A.
21 school teacher of English language
Jizzakh region, Sharaf Rashidov District
Melibayeva M.S.
student of 21-school
Sharaf Rashidovsky district of Jizzakh region, Uzbekistan

FAMOUS PEOPLE OF UZBEKISTAN

Annotation: The article analyses the lifes, works, contributions of the Uzbek scholars to the development of sciences

Keywords: Abu-Rayhon Beruniy, Al-Khorezmi Muhammed Bin – Mussa, Alisher Navoi

Abu-Rayhon Beruniy

Abu-Rayhon Beruniy – a remarkable scientist, amazing with variety of his scientific interests, boldness of idea, the author of more than 150 works devoted to actual issues of natural sciences, philosophy, history, philology, great encyclopaedist – the thinker, the humanist of the Middle Ages epoch. Outlook of Abu-Rayhon Beruniy was formed at the end of X – the beginning of XI century in Central Asia. He was born on 2 Zu-ul-hidja in 362 (on September 4, 973 A.D.) in suburb of Kyat, former feudal capital of Khorezm. On the native land he has received good education and from a youth began his scientific activity. Due to political events in Khoresm Beruniy left the native land and approximately in between 998-1004 lived in Gurgan, at southeast coast of Caspian Sea. At this time he has done a great work – «Monuments of the past generations ». In about 1005 Beruniy came back to Khorezm, where at a court yard of the Khorezm king Abu Abbas Mamun ibn Mamun (1009-1017) occupied honorable position. In 1017 Mahmud Gaznavi (998-1034) has subordinated to himself Khoresm, and in the same year Beruniy together with some other scientists had been compelled to follow the conqueror to Hansa where he stayed up to the end of his life.

Despite the unfavorable conditions for him in the capital Mahmuda, Beruniy was entirely given to scientific researches.

Together with the army of sultan, Beruniy had several times visited India. He has taken advantage of the trips for studying this country and as a result, by 4030 he had written an outstanding composition on India. Earlier, in 1025 Beruniy finished "Geodesy". To sultan Masud (1030-1041), the receiver Mahmud, Beruniy has devoted his main work on mathematics and astronomy – « Masudov kanon ». At government of the subsequent sultan – Masud (1041 - 1048) – Беруни written the big work on mineralogy, and at the end of a life – "Saydan". He died in Gazna 2 Radjab 440. (on December 11, 1048).

Al-Khorezmi Muhammed Bin - Mussa

(783 - 850)

Nickname Al – Khorezmi specifies his native land – the Central Asian state Khoresm (nowadays territory of Uzbekistan), Bin Mussa – "son of Mussa", and one of nicknames of the scientist – Al – Madjusi– speaks about his origin from a sort of magicians (on – Arabic "madjus"). It shows also, that one of sources of knowledge of Mohammed Al – Хорезми was science prior to Islamic Central Asia the keepers of which were magicians. He managed in Baghdad the library of wisdom House of some sort of the Baghdad academy at caliphate of Al – Mamun. There were the arithmetic treatise « The Book about the Indian account », the algebraic treatise « The Brief book about calculation of algebra and almukabal», astronomical tables and a geographical path. Both mathematical treatises have been translated into Latin language of medieval Europe and served for a long time as the basic textbooks on mathematics. Nickname Al-Khorezmi in the modified form has turned to a nominal word "algorithm" and all over again meant all system of decimal item arithmetics. Subsequently this term has received a wider sense in mathematics as a rule performing operations in certain order. Thus, actions « Al - Djebr» and "Al-Mukabala" have replaced with themselves transfer of nowadays-used equation members from one part of the equation into another and reduction of similar members. These two operations have allowed Al – Khorezmi to transfer any algebraic equation of the first and second degree into initial forms which Al – Khorezmi has six.

Unlike Greeks who, certainly, also solved quadratic equations, but solved in geometrical way, Al – Khorezmi used drawings only for explanation of the rhetorical decision validity. He could solve any quadratic equation by his general rule (finding positive roots). If Greeks had geometrical solutions the method Al – Khorezmi was almost algebraic. This is an enormous step forward in comparison with geometrical algebra of Greeks. In the arithmetic treatise Al – Khorezmi basically followed the Indian samples, and from him the Europeans have got familiar with the Indian methods of recording the numbers, that is the use of zero and location of figures values. The algebraic path differed from both works, that of Indian mathematicians, and Greeks. It can be believed, that in this book Al – Khorezmi followed local traditions and own results. If the majority of Greeks did not see necessity to apply the scientific knowledge to practical needs, the main desire of Al – Khorezmi was to place a science to serve to humankind and to adapt it for the practical purposes. In Algebra Al – Khorezmi has a section about trade and commercial transactions, with problems on a threefold Rule. Thus, for the first time in a history of mathematics in the treatise of Al – Хорезми have appeared the general rules of solving the quadratic equations.

Alisher Navoi

An ingenious poet and the thinker, the musician and the artist, the teacher and the scientist, a great statesman and one of the most cultural persons of his

time. Alisher Navoi was the conventional head of the cultural life of Herat, the patron of numerous representatives of sciences, arts and cultures. “Due to Alisher many people have received literary and art education and talent strengthening and there is no any other patron and the tutor of people as Alisher”. - wrote Babur Alisher Navoi was born on February 9, 1441 in the city of Herat, the capital of Huroson State.

From the childhood Alisher was interested in reading the works of classics of Persian-Tadjik literature: Saadi, Attar and others. According to Navoiy himself, such poets as Lutfi Sheikh Kemal Turbati have directed, assessed the verses written by him. Navoiy studied at the most educated people of that time, took part in their highly intellectual and deeply instructive conversations.

Having no family, no children, no successors, the poet spent a significant part of his huge wealth for charity. He has constructed a lot of educational institutions, hospitals, a caravan–sheds, channels, bridges and roads.

In Herat **Навои** maintained the closest relations with the great Tadjik poet and thinker Abdurrahman Dzhami (1414 - 1492) who was his closest friend, the adherent, the teacher and the spiritual instructor. Friendship of Navoiy and Dzhami remain in a history for ever as a bright symbol of friendship between Uzbeks and Tadjiks.

By the time when Navoiy became one of the outstanding persons in Hurasan, having received a honorable post at a court yard, he already had reputation of the masterly master of a verse. The generosity of his talent was that the poet has captured all versions of lyrical works created by peoples of the Muslim East during many centuries. Gazals and kitas, tarjibans and rubai– in what genre would not act **Навои**, he proved everywhere with shine boundless opportunities of his talent and skill.

Many known representatives of the literature, art and science of second half 15 – the beginning of 16 century, as a token of deep respect for Alisher Navoi and in gratitude for his support, devoted to him their works.

The image of this versatile and talented person historically is not separable from the broad audience of his contemporaries, friends, admirers and direct pupils – poets and musicians, scientists and architects, calligraphers and artists, historians and the writers, who defined their activity as cultural blossoming of Herat « epoch of Nabvoiy ».

Навои has died On January 3, 1501 in Herat. All Herat saw off to last way its favorite poet and the wise figure. The mourning concerning Alisher Navoi's death lasted during the whole year - so great was the love to the person who has devoted all talent and skills to the people who had been indefinitely loved by him.

Alisher Navoi's literary heritage is very huge. In it we find the set of fine poems, epic products, scientifically – philosophical pathes, literary researches, biographies of scientists, poets, philosophers, works on a history, on linguistics.

On the top of poetic creativity of Navoi is creation of "Hamsa" – a cycle from five poems: « Confusion just », « Layli and Madjnun», « Farhad and Shirin», « About seven wanderers », « Wall of Iskandar».

The spiritual heritage of the remarkable son of Uzbeks presently gets to be known internationally, it becomes the property of everyone, to whom the interests of the world, friendship and nations unity is valuable.

Used literature:

1. https://www.marakandatavel.com/en/about-uzbekistan/uzbekistan_general-info/famous-persons/index.html
2. <https://study.by/poleznaya-informatsiya/sistemy-obrazovaniya/468/>

*Bobobekova J.A.
21 school teacher of English language
Jizzakh region, Sharaf Rashidov District
Turgunova Sh.J.
student of 21-school
Sharaf Rashidovsky district of Jizzakh region, Uzbekistan*

EDUCATIONAL SYSTEM IN GREAT BRITAIN TYPES OF SCHOOLS

Annotation: Children's education in England is normally divided into two separate stages. They begin with primary education at the age of five and this usually lasts until they are eleven. Then they move to secondary school, there they stay until they reach sixteen, seventeen or eighteen years of age.

Keywords: education, grammar schools, technical schools, modern schools

All British children must stay at school from the age of 5 until they are 16. Many of them stay longer and take final examination when they are 17 or 18. Before 1965 all children had to go through special intelligence tests. There were different types of state secondary schools and at the age of 11 children went to different schools in accordance of with the results of the tests.

State schools are divided into the following types:

-Grammar schools. Children who go to grammar schools are usually those who show a preference for academic subjects, although many grammar schools now also have some technical courses.

-Technical schools. Some children go to technical schools. Most courses there are either commercial or technical.

-Modern schools. Boys and girls who are interested in working with there hands and learning in a practical way can go to a technical schools and learn some trade.

-Comprehensive schools. These schools usually combine all types of secondary education. They have physic, chemistry, biology laboratories, machine workshops for metal and woodwork and also geography, history and art departments, commercial and domestic courses.

There are also many schools which the State doesn't control. They are private schools. They charge fees for educating children and many of them are boarding schools, at which pupils live during the term time.

After leaving school many young people go to colleges or further education. Those who become students at Colleges of Technology (called "Techs") come from different schools at different ages between 15 and 17. The lectures at such colleges, each an hour long, start at 8,15 and end at 4,45 in the afternoon.

British Schools Schooling is voluntary under the age of 5 but there is some free nursery school education before that age. Primary education takes place in

infant schools for pupils ages from 5 to 7 years old and junior schools (from 8 to 11 years). Some areas have different systems in which middle schools replace junior schools and take pupils ages from 9 to 11 years.

At the age of 16 pupils take school-leaving examinations in several subjects at the Ordinary level. The exam used to be conducted by eight independent examining boards, most of them connected with the university. This examination could also be taken by candidates at a further education establishment. This exam was called the General Certificate of Education (GCE). Pupils of comprehensive school had taken the examination called the Certificate of Secondary Education either with or instead of the GCE.

A GCE of Advanced ("A") level was taken two years after the Ordinary level exam. It was the standard for entrance to university and to many forms of professional training. In 1988 both examinations were replaced by the more or less uniform General Certificate of Secondary Education.

The private sector is running parallel to the state system of education. There are over 2500 fee-charging independent schools in GB. Most private schools are single-sex until the age of 16. More and more parents seem prepared to take on the formidable extra cost of the education. The reason is the believe that social advantages are gained from attending a certain school. The most expansive day or boarding schools in Britain are exclusive public schools like Eton college for boys and St. James' school for girls.

Universities and Colleges in Great Britain.

Full courses of study offer the degree of Bachelor of Art or Science. Most degree courses at universities last three years, language courses 4 years (including year spent aboard). Medicine and dentistry courses are longer (5-7 years).

Students may receive grants from the Local Education Authority to help pay for books, accommodation, transport, and food. This grant depends on the income of their parents.

Most students live away from home, in flats or halls of residence.

Students don't usually have a job during term time because the lessons called lectures, seminars, classes or tutorials (small groups), are full time. However, many students now have to work in the evenings.

University life is considered «an experience». The exams are competitive but the social life and living away from home are also important. The social life is excellent with a lot of clubs, parties, concerts, bars.

There are not only universities in Britain but also colleges. Colleges offer courses in teacher training, courses in technology and some professions connected with medicine.

Educational System in the USA The general pattern of education in the USA is an eight-year elementary school, followed by a four-year high school. This has been called 8—4 plan organization. It is proceeded, in many localities, by nursery schools and kindergartens. It is followed by a four-year college and professional schools. This traditional pattern, how ever, has been varied in many

different ways. The 6—3—3 plan consists of a six-year elementary school, a three-year junior high school, and a three-year senior high school. Another variation is a 6—6 plan organization, with a six-year elementary school followed by a six-year secondary school

The elementary school in the United States is generally considered to include the first six or eight grades of the common-school system, depending upon the organization that has been accepted for the secondary school. It has been called the "grade school" or the "grammar school"

There is no single governmental agency to prescribe for the American school system, different types of organization and of curriculum are tried out.

The length of the school year varies among the states. Wide variation exists also in the length of the school day. A common practice is to have school in session from 9:00 to 12:00 in the morning and from 1:00 to 3:30 in the afternoon, Monday through Friday. The school day for the lower grades is often from 30 minutes to an hour shorter. Most schools require some homework to be done by elementary pupils. Elementary Schools, High Schools and Institutions of Higher Learning

Elementary Schools, High Schools and Institutions of Higher Learning

There are eight years of elementary schooling. The elementary school is followed by four years of secondary school, or high school. Often the last two years of elementary and the first years of secondary school are combined into a junior high school.

The school year is nine months in length, beginning early in September and sometimes a shorter one in spring. There are slight variations from place to place. Students enter the first grade at the age of six and attendance is compulsory in most states until the age of sixteen or until the student has finished the eighth grade.

The elementary schools tend to be small. The high schools are generally larger and accommodate pupils from four or five elementary schools. A small town generally has several elementary schools and one high school. In some rural communities the one-room country school house still exists. Here may be found from five to twenty-five pupils in grades one through eight, all taught by the same teacher.

Admission to the American high school is automatic on completion of the elementary school. During the four-year high school program the student studies four or five major subjects per year, and classes in each of these subjects meet for an hour a day, five days a week. In addition, the student usually has classes in physical education, music, and art several times a week. If he fails a course, he repeats only that course and not the work of the entire year. Students must complete a certain number of courses in order to receive a diploma, or a certificate of graduation.

Used Literature:

1. <https://www.learnenglish.de/culture/educationculture.html>
2. Leach A.F. The Schools of Medieval England. – London : Methuen & Co. Ltd., 1915. - 376 p.
3. Taylor T. A New Partnership for Our Schools // Report of the Committee of Enquiry. –London : HMSO, 1977. - 597 p.

HASHIM IBN HAKIM (MUKANNA) AS A HISTORICAL PERSON

Annotation: This article provides information about the Muqanna uprising in the land of Turan during the Arab rule and the personality of Muqanna. In addition, the Arab government in power and its specificity, as well as the main factors that led to popular discontent, were discussed in detail.

Keywords: Muqanna, white-clad, Turan, Arabs, Tabari, Islam, Samarkand, Kesh, Hakim, Movorounnahr, Khorasan, Abbasids, Arab Caliphate, Uprising.

The Arabs had conquered almost the entire territory of Central Asia and began rule over this country by the middle of the eighth century. Arabic began to be used as the state language. The local population was widely encouraged to convert to Islam. It is no secret that Hashim ibn Hakim, who lived in the history of Turan and Iran during the Arab rule and played an important role in a number of historical events, has different views on Muqanna. It is well known that written sources provide us with information about historical events, past individuals and their activities. It is said that in the time of Muqanna, as in the countries subject to the Arab caliphate, the position of the Arabic language in political and scientific relations in our country was strong. For this reason, Arabic sources, as well as their subsequent Persian translations and other sources, can provide us with valuable information about this historical figure. In particular, written information about Muqanna is given in Muhammad Jarir Tabari's (839-923) "History of Prophets and Kings", Abu Bakr Narshahi's (899-959) "History of Bukhara", Ibn al-Asir's (1160-1233) "Perfect History" and others is cited in many other similar works. They negatively assessed Muqanna's personality and activities. Even today, there are a number of articles, information and opinions in the press and on the Internet that are very negative about Muqanna. In advancing their views, the authors rely mainly on the Arabic or Persian sources we have listed above, as well as on data from the scientific literature created decades ago. In this sense, it should not be overlooked that the above-mentioned written sources were written mainly in palaces, initially defending the interests of the Arab or Muslim class in the hands of the official government, while later sources preferred the ideological interests of local ruling dynasties and Sunni sects. For example, the aforementioned historian, philosopher, jurist, and poet, Muhammad Jarir Tabari, grew up in an Islamic environment from an early age and was brought up on the basis of these values. His History of the Prophets and Kings was completed in 914, one hundred and thirty years after Muqanna's death. His work on the interpretation of the Qur'an has also survived to this day. Tabari is one of the most

respected Sunni historians. Another of the authors who gave a complete assessment of Muqanna's personality and his rebellion is, as mentioned, Abu Bakr Narshahi. He wrote his History of Bukhara in Arabic in 943-944, thirty years after Muhammad Jarir Tabari, and dedicated it to the Samanid ruler Abu Muhammad Nuh (943-954).

It was natural for Abu Bakr Narshahi, who wrote a century and a half after the time of Muqanna, to rely on the writings of other authors in covering the subject. According to the historian, he covered the subject of Muqanna on the basis of information obtained from Abu Ishaq Ibrahim Suli's Akhbori Muqanna. It is difficult to say exactly how Abu Bakr Narshahi used the primary source, what was corrected and what parts were removed in his later editions and abridgments, as this work has not reached us, and the "History of Bukhara" itself has been edited and abridged several times in recent centuries. In any case, we now have at our disposal not the original of the "History of Bukhara" written in Arabic, but a Persian edition, which was later reworked in different periods.

Based on the above two sources, the following information about Muqanna can be obtained. For example, Muhammad Jarir al-Tabari writes that Muqanna's real name was Hashim ibn Hakim, a village near his native Marw. Abu Bakr Narshahi said that Muqanna was from Balkh. The reason why medieval historians give such information is probably that Muqanna's native village was located between Marv and Balkh.

It is also incorrect to consider these areas as lands that have nothing to do with the history and statehood of the Uzbek people, as some modern authors interpret today. It is well known that Merv, Balkh, Juzjan, Herat and many surrounding regions have long been closely connected with the history of the Uzbek people and statehood.

Hashim ibn Hakim used to cover his face with a veil because his face was ugly and one eye was blind. That is why he got the nickname "muqanna" in Arabic, which means "masked". There are also reports that Muqanna took part in Abu Muslim's revolt against the Umayyads who ruled the caliphate (747-750). According to Abu Bakr Narshahi, Abu Ja'far al-Dawani (754-775), one of the Abbasid caliphs, became the commander of the Khurasan army at a time when the struggle for power was just beginning to appear in the political arena. He was later promoted to the post of minister of the Arab Caliphate's viceroy in Khorasan, Abduljabbor Azdi (757-759).

He wrote letters to people with great influence in the surrounding lands, demanding that they confess. People began to follow Muqanna. He formed an army consisting of various ethnic groups, nomads and settlers. Abu Bakr narrates that Narshahi Muqanna's father was a general. It is also possible that he himself won the trust of the Turkic peoples who were leading the military at that time because he was a military man for some time. However, the sources do not contain records of his ethnicity.

According to Muhammad Jarir Tabari, Muqanna, who revolted in Khorasan, propagated the idea of the migration of spirits and claimed that such a spirit had migrated to him as well. However, due to the strong position of the Arabs in Khorasan, Muqanna fled there with thirty-six supporters. Abu Bakr Narshahi, on the other hand, writes that he “mised” many people in Khorasan and came to Movarounnahr to gather his followers.

Crossing the Amudarya, Muqanna came to Kesh province, where he managed to gather a large number of henchmen and settled in one of the mountain fortresses, calling on the nomadic forces for help. Thus, the Muqanna revolt covered the whole of Movarounnahr. The rebels, who chose local white clothing against the black paint on the official dress of the Abbasid-ruled caliphate, called them “white-clad”.

Muqannas also visited Bukhara and Samarkand. In the wake of the movement's rise, Caliph Muhammad Mahdi (775-785) sent a number of his military commanders against him. Mu'adh ibn Muslim, the leader of them and the viceroy of Khurasan, fought against the rebels for two years and did nothing.

In 775-776, Muqanna's supporters captured the Navokat fortress around Kesh. According to information left by Abu Bakr Narshahi, in the 8th century, the people of the village of Subah in Kesh Province, under the leadership of their peasant Amr, killed an Arab nobleman and joined the Muqanna uprising and openly converted to his religion.

During the reign of Musayyab ibn Zuhayr, who succeeded Mu'adh ibn Muslim, the rebels began to be defeated by the Muslims. As a result of the siege of Kesh Fortress in 163 / 779-780, they were exhausted. Muqanna felt defeated and all of them perished because of poisoning himself and his wives. The Muslims invaded the fortress, beheaded him and sent him to the Caliph Muhammad Mahdi, who was in Aleppo at the time.

It should not be forgotten that the written sources written by the supporters of the Muqanna movement and reflecting their views are not in the hands of us, i.e. the scientific community, more precisely, they have not been identified so far. Therefore, in analyzing Muqanna's personality and rebellion, it is not correct to rely solely on information from Muslim sources, which are written only in a one-sided way, condemning him and evaluating his activities. The Muqanna movement is, to a certain extent, a historical event that expressed the dissatisfaction of the people of that time, the people, with the Arab invasion, oppression and oppression. In this sense, this uprising can be called the liberation struggle of the peoples of the country. It is also not permissible to deify the Arab administration that ruled our country at that time and to describe them as individuals with the qualities of today's arrogant Muslims. This is because there is a lot of information in the sources about the inequality, oppression, additional taxes and duties imposed on the non-Arab population by the Abbasids.

References:

1. Abu Bakr Narshahi "History of Bukhara"
2. Ibn al-Asir, "Perfect history", T.: "Uzbekistan", 2006
3. Muhammad Jarir Tabari "History of Prophets and Kings"
4. Abu Rayhan Beruni, "Monuments of Ancient Peoples" T.: "Science", 1968
5. UzME. First volume. T.:2000 y

*Bohdaniuk O.V., PhD
Associate Professor of the Department of Statistics and Economic Analysis
National University of Life and Environmental Sciences of Ukraine
Ukraine, Kiev*

CLASSIFICATION OF INCOME FROM OPERATING ACTIVITIES AS A BASIS FOR THE ORGANIZATION OF ITS ACCOUNTING AND ANALYSIS

Annotation. The article considers the classification of income, which is one of the important components of enterprise management, which is enshrined in the relevant regulations and recognized by individual researchers and scientists. It is investigated that clear structuring of incomes of enterprises promotes full understanding of their economic content and essence, correct definition of structure, comprehensive assessment of a tendency of change in time and acceptance of optimum and reasonable management decisions.

Key words: income, classification, accounting, analysis, Ukraine

Income management of the entity requires reasonable detailed classification based on the grouping of income by certain characteristics for the purposes of accounting, analysis and control. Therefore, classification is the most important element for building an income management system.

In order to generate income and calculate its amount in accounting allocate income from: sales of products, goods, other assets acquired for sale; provision of services; use of the company's assets by other individuals and legal entities, resulting in interest, dividends, royalties, etc.

Such scientists as F. F. Butynets and N. M. Malyuga [1] propose to divide the income from operating activities according to the economic content of the operations that form them. They distinguish the following types of income: income from sales (which include income from sales; income from services rendered and work performed; income from the sale of fixed assets; income from the sale of intangible assets in the form of royalties; income from sales of inventories, low-value and perishable items, foreign currency, etc.) and non-operating income generated during operating activities (income from fines, penalties, from the write-off of accounts payable that arose during the operating cycle after the expiration of the statute of limitations, income from gratuitous current assets, etc.). This division of income from operating activities makes it possible to more clearly analyze them in the enterprise.

Accounting Standard 15 "Income" recommends the classification of recognized income in financial and management accounting by the following groups: income (revenue) from sales of products (goods, works, services); other operating income; financial income; other income; extraordinary income [2].

Accounting proposes to divide the income of the enterprise on the terms of their recognition in the financial statements for income for the reporting period and income for future periods. The former include income to be received and received in the reporting period, as well as those that were to be received, but for various reasons were not received in the reporting period. The second category is formed by income that was not subject to receipt in the reporting period [3, p. 94].

In order to effectively manage the income of the enterprise in practice, it is important to divide it according to the nature of taxation. For this purpose, income that is subject to taxation and income that is not subject to taxation in accordance with the provisions of the Tax Code of Ukraine are distinguished [4].

For the purpose of taxation, the company's income is recognized and classified by national Standards. It should be noted that in accounting recognized income of the enterprise is classified according to a wider list of groups than in accounting to determine the object of taxation in the Tax Code of Ukraine (Fig.):

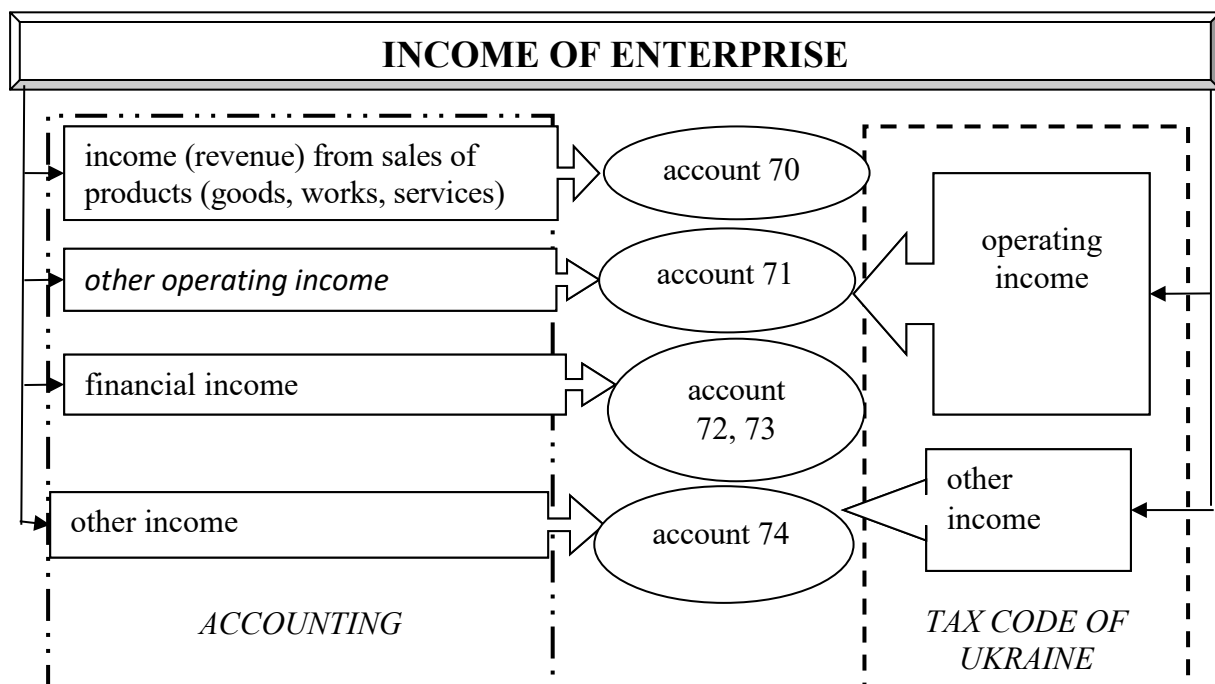

Fig. Classification of income according to accounting and Tax Code of Ukraine

According to the Tax Code of Ukraine (TCU), income is divided into: "income from operating activities" and "other income". P. 135.4. Art. 135 TCU provides a definition of income from operating activities, which is recognized in the amount of contractual (contractual) value, but not less than the amount of compensation received in any form, including the reduction of liabilities of the enterprise. This group includes two categories of income (paragraphs 135.4.1. and 135.4.2.) - income from the sale of goods, work performed, services rendered, including the remuneration of the commission agent (attorney, agent, etc.) and income of banking institutions. In particular, the TCU states that it refers to the

income of banking institutions (paragraph 135.4.2. Article 135). This has a positive effect on the classification of income by the taxpayer and allows to clearly define the procedure for recognizing such income. All other income, the register of which is not limited, belongs to the group "other income".

Thus, the type of operating activity of the enterprise, which generates its income, is one of the important features of the classification, which is enshrined in the relevant regulations and recognized by individual researchers and scientists. Thus, according to this classification feature distinguish income from the main activities of the agricultural enterprise and income from other types of its operating activities. Such classification of incomes from operating activity is the basis of formation of the report on financial results of the enterprise.

Consider two more classification features of enterprise income from operating activities, in addition to the above.

The first of these additional features should be used to classify operating income by level of management. For this purpose it is offered to allocate:

- 1) income generated by the results of a particular transaction;
- 2) income generated by individual centers of responsibility ("income centers", "profit centers") of the enterprise;
- 3) income generated by the enterprise as a whole.

The second of these additional features should classify income from operating activities of the enterprise according to the level of price risk of their formation. On this basis, distinguish:

- 1) income from operating activities, which are formed under conditions of minimal price risk;
- 2) income from operating activities, which are formed under conditions of average market price risk;
- 3) income from operating activities, which are formed under conditions of high price risk.

This distribution of income will more clearly coordinate their formation with the relevant types of pricing policy for certain types of operating products of the enterprise, as well as provide measures for forms of price risk insurance in order to obtain the planned income from operating activities.

Thus, the classification of income from operating activities of enterprises is of great importance for both financial and management accounting. Clear structuring of enterprise revenues contributes to a full understanding of their economic content and essence, the correct definition of the composition and structure, a comprehensive assessment of the trend over time and the adoption of optimal and sound management decisions.

References:

1. Бондарчук Н.В. Удосконалення управлінського обліку реалізації продукції в сільськогосподарському. *Молодий вчений*. 2016. № 12.1 (40). С. 647-650.

2. Положення (стандарт) бухгалтерського обліку 15 „Дохід”: затверджене наказом Міністерства фінансів України від 29 листопада 1999 р., № 290
URL: <http://www.zakon.rada.gov.ua>
3. Николаева В. П. Класифікація доходів з операційної діяльності підприємства В.П. Николаєва . *Економіка АПК*. – 2009. – № 10. – С. 91-95.
4. Податковий кодекс України URL:
<http://zakon4.rada.gov.ua/laws/show/2755-17?nreg=2755-17&find>

Bokiyev M.
assistant
of Andijan State Medical Institute
Mamazulunov N.
assistant
of Andijan State Medical Institute

SOME BIOLOGICAL ACTIVE PRODUCTS OF METALLOCENES

Annotation: The article provides information about ferrocene and its derivatives containing iron, as well as biologically active substances containing ferrocene

Keywords: ferrocene, cyclopentadiene, ferrostimulants, siacrine, bioglue, ferrocerone

Kili and Poson synthesized in 1951 a specific compound of cyclopentadiene, disiclopentadienyltemyl, often called ferrocene. It can be obtained from a magnesium compound of cyclopentadiene and iron (II) chloride (I), cyclopentadiene with heated Fe (II) and iron (II) chloride (III) in the presence of Na, freshly cracked cyclopentadiene (IV) [1].

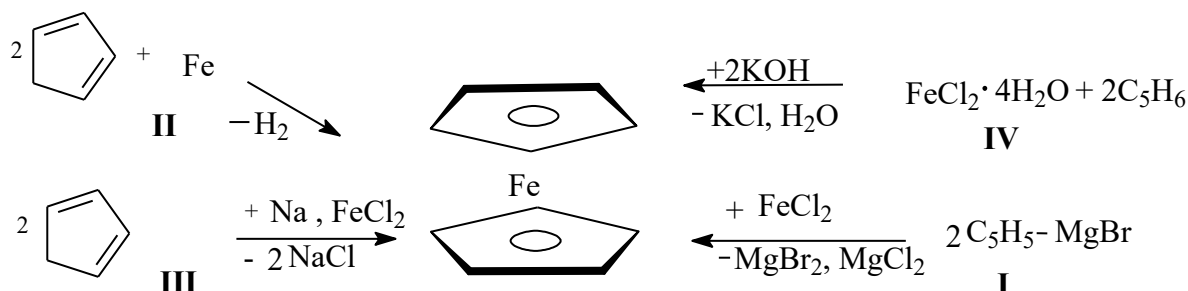

Ferrocene is a complex organic compound containing iron (Fe), a metalloorganic substance with a sandwich structure.

In 1952, as a result of X-ray structural analysis, E. Fisher in Germany, G. Wilkinson in England and R. Woodward in the United States proposed to name dicyclopentadienyltemir "Ferrocene" and also its structural formula. According to this structure, the Fe atom is located between two symmetrical cyclopentadienyl (C₅H₅) rings [2].

Ferrocene can even be obtained from some amine bases (diethylamine) by deprotonation (V), iron from pentacarbonyl (VI), and other metallocenes (VII) [3].

Several scientists, including the German scientist W. Schlyogl, the American scientist R. Woodward, the Russian A. N. Nesmeyanov, N. S. Kochetkova, contributed to the development of ferrocene chemistry with their

students. These scientists have found that ferrocene can easily enter into reactions such as exchange and aggregation, just like aromatic hydrocarbons [2-4].

A.N. Nesmyanov studied in detail the ability of ferrocene to react with aryldiazonium, and showed that the reaction can form ferrocene compounds with different structures [5].

Lutle et al proposed the arylation reactions of ferrocene in the presence of sulfuric acid [6].

As a result of the research, aryl derivatives containing halides, nitro and carboxyl, alkyl, acetyl, cyanide groups were synthesized, isolated and their structure was studied.

The purely isolated metallocene derivatives can be summarized as follows:

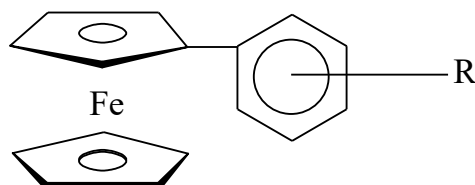

R = OCl, OCH₃, OC₂H₅, o-COOCH₃, p⁻ COOC₂H₅, m⁻ COOC₂H₅, O-CH₂OH, m=COOH
o=CH₃, p=CN

The arylation reaction of ferrocene was studied in detail by A. Kasahara and others, and the reaction of the following structure was carried out. As a result, dialysic arylaldehyde salts and other derivatives of ferrocene were synthesized, and their structure was studied by IR, NMR, and MASS spectra [7].

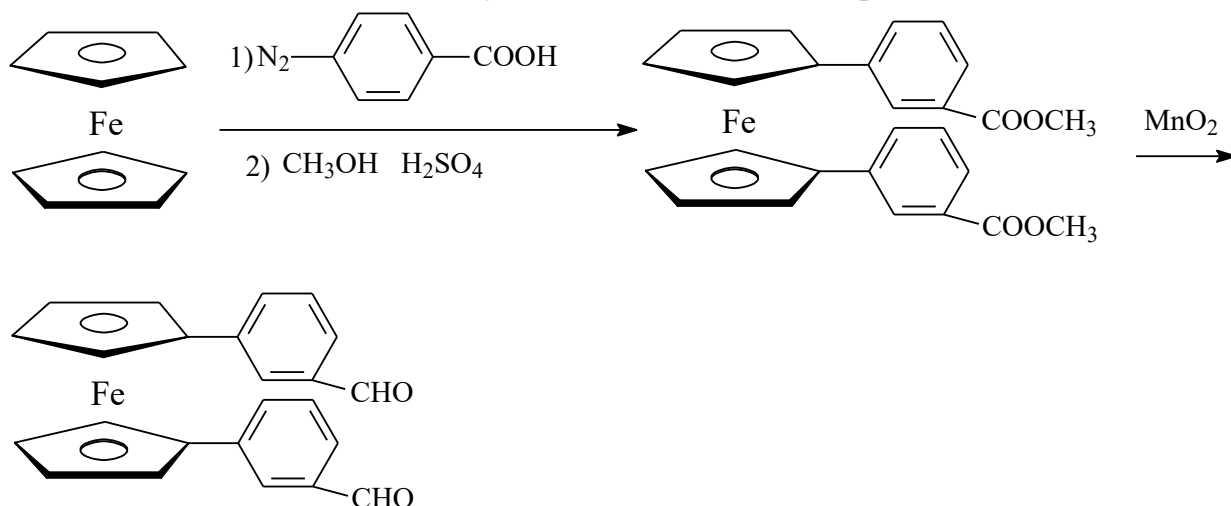

Through these reactions, the ferrocene, represented by metallocenes, exhibits aromatic properties by easily exchanging its hydrogen for other functional groups according to the environment. An example of this is ferroquine, which is widely used in the treatment of anemia:

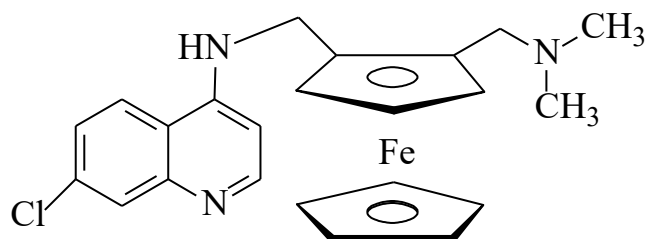

In the scientific laboratory "Commodity Chemistry" of Andijan State University biostimulators "Ferrostimulators", "MAXIX", "MAKSIT", "ADUMAX", "Ferbek-P" and "Ferbek-PD" were synthesized and put into practice. These biostimulants not only accelerate the growth of the plant, but also have a positive effect on seed germination and overall development of the plant, and increase productivity by 3-4 s / s.

One of the medicinal properties of ferrocene compounds is that they can treat several diseases at the same time. For example, ferrocene-containing substances such as ferrocene, askin, siacrine AP-1, siacrine AndMos [8, 9]. In particular, ferrocene has been shown to be effective in the treatment of severe anemia, as well as in the treatment of anemia. Or the sodium salt of p-ferrocenylphenol has been proven to cure not only anemia but also colds. Its main features have been proven to be significantly superior to existing analogues in the world, as well as its ability to treat radiation sickness, one of the most serious problems of our time. p-ferrocenylphenol-based siacrine bioelements were obtained. These bioelements differ from their cyanacrine-based analogues in several respects. The glue does not stick to the hands of surgeons and medical devices. The rate of transition to the working position is 1.5-2 times faster, which prevents the formation of various pus on the operated surface. Accelerates tissue to a normal life cycle. It is obvious that the physiological activity of ferrocene and its derivatives, their low cost, allows them to benefit greatly from their widespread use in the national economy. Based on the above, it can be concluded that ferrocene-based many of the new chemicals obtained show high biological activity. The main reason why ferrocene derivatives exhibit such positive properties can be explained by the fact that its structural structure is close to that of the gem, which is the most active compound in the cells of living organisms.

It is known from the biochemical literature that heme-containing enzymes are actively involved in the metabolic process in all living organisms. In particular, the cytochrome system is one of the key enzymes in the final stages of the redox process in the cell, the final product of metabolism - the formation of water and carbon dioxide. That is, without this cytochrome system, the metabolic process in cells and tissues will not end. This means that ferrocene-based drugs are involved in cellular metabolism and may be involved in the regulation of certain processes in living organisms.

References:

1. Kealy T.J, Pauson P.L - Nature, 1951, Vol. 168, r.1039

2. Nesmeyanov A.N., Perevalova E.G., Golovnya R.V., Shilovtseva L.S. - About alkylferrocenax and fer-rotsenilamine - DAN USSR, 97, 459-461 (1954)
3. Jump up to: a b Wilkinson, G. (1956). "Ferrocene". Organic Syntheses. 36:31 doi: 10.15227/orgsyn.036.0031 .; Collective Volume, 4, p. 473
4. Nesmeyanov A.N., Perevalova E.G., Golovnya R.V., Shilovtseva L.S. - About alkylferrocenax and fer-rotsenilamine - DAN SSSR, t. 102 № 3, 535- 538 (1955)
5. Nesmeyanov A.N. - "Substitutions in the ferrocenenuc - leus" Proc. Royal Soc. (London), 246, 495 (1955).
6. Little W. F., Lynn K. N., Williams R.- Novel Side Reaction Accompanying the Arylation of Ferrozene. An Example of Free Radical Sudstation. J. did., Vol. 30055 (1963)
7. Askarov IR, Khojimatov MM, Kirgizov Sh.M., Otakhonov QQ - "Synthesis of some aromatic compounds of metallocenes" Scientific Bulletin, (AUL) №2, 42,43-p (2014).
8. Abdulloyev O.Sh. Iron-containing biostimulants, their classification and certification: dis. .. chemistry f. fals. Doc (PhD): 02.00.09 // Abdulloyev O.Sh. - Andijon, 2018. - P. 123.
9. Askarov I.R., Kyrgyzov SH.M. Ferrocene and its prospects in agriculture. // Problems and prospects of classification and certification of goods on the basis of chemical composition. Scientific-practical conf. materials. - Tashkent, 2013. - P. 327-331.1

Bozorov E.H.
professor
O'zbekiston Respublikasi Fanlar Akademiyasi
Yadro Fizikasi instituti f.-m.f.d.
Jo'rayev M.Qa.
ass.
Buxoro Muhandislik Texnologiya instituti
"Elektr mexanikasi va texnologiyalari"

**DUNYODA YADRO ENERGETIKASI TARAQQIYOTI
RIVOJLANISHINI AMALIY AHAMIYATINING INNOVATSION
TEXNOLOGIYALARDAGI BOSQICHLARI**

Annotatsiya: Maqolada qayta ishlangan statistik ma'lumotlar asosida dunyoda atom energetikasining rivojlanish tendentsiyalari pedagogik tahlil qilingan. Bugungi kunda dunyo nafaqat yadroviy energetikaning resurs bazasini kengaytirish, balki boshqa energiya manbalariga nisbatan raqobatbardoshligini ta'minlash bilan birga yadro chiqindilari, yadro qurollarini tarqatmaslik muammosini hal qilishga imkon beradigan istiqbolli xavfsiz yadro texnologiyalarini rivojlantirishga katta e'tibor qaratmoqda.

Kalit so'zlar: atom energetikasi, yadro texnologiyasi, reaktor, yadro xavfsizligi

Bazarov E.J.
professor
Academy of Sciences of the Republic of Uzbekistan
Institute of Physics
Juraev M.K.
"Electromechanics and Technology"
Bukhara Institute of Engineering and Technology

**STAGES OF THE PRACTICAL SIGNIFICANCE OF THE
DEVELOPMENT OF NUCLEAR ENERGY IN THE WORLD IN
INNOVATIVE TECHNOLOGIES**

Annotation: The article provides a pedagogical analysis of trends in the development of nuclear energy in the world on the basis of processed statistical data. In conclusion, it is concluded that today the world pays great attention to the development of promising safe nuclear technologies that allow not only to expand the resource base of nuclear energy, but also to solve the problem of non-proliferation of nuclear waste and nuclear weapons, while ensuring its competitiveness in comparison with other energy sources

Keywords: nuclear power engineering, nuclear technologies, reactor, nuclear safety

O‘zbekiston Respublikasi Prezidenti Shavkat Mirziyoyev 2020-yil 27 fevral kuni “Pedagogik ta’lim sohasini yanada rivojlantirish chora-tadbirlari to‘g‘risida”gi qarorni imzoladi.

Maskur qarorda mamlakatimizda ta’lim-tarbiya tizimini yangi bosqichga ko‘tarish, pedagog kadrlar tayyorlash sifatini ilg‘or xalqaro standartlar asosida takomillashtirish va oliy pedagogik ta’lim bilan qamrov darajasini oshirish borasida izchil chora-tadbirlar amalga oshirish ko‘zda tutilgan⁵.

Ushbu qarorga muvofiq oliy ta’limda yadro energetikasi fani mavzularini o‘qitishda har bir talaba bilan alohida ishlab, uning ichki kompetentsiyasidan kelib chiqqan holda tanlangan pedagogik metod asosida mavzuning qanchalik dolzarb ekanligini tushuntirish kerak. Dunyoda yadro energetikasi taraqqiyoti rivojlanishining amaliy ahamiyati innovatsion texnologiyalardagi bosqichlari mavzusini talabaga yetgazishda alohida ochib berilgan mohiyatini “toifalash jadvali” orqali tushuntirib o‘quvchiga didaktik metod bo‘yicha eslab qolishi, o‘zining shaxsiy fikrlarini ayta olishi va o‘rgangan terminlari haqida kengroq tushuncha paydo bo‘lishiga olib keladi. Hozirda yangi pedagogik texnologilar o‘quvchilarni individual fikrlashiga yordam beradi. Bu esa kelajakda yadro energetikasi fanining mohiyatini o‘rganishda muhim omil bo‘lib xizmat qiladi. Tadqiqotning maqsadi yadroviy texnologiyalarni rivojlantirishning global tendentsiyalari sharoitida atom energetikasini rivojlantirish istiqbollari yangi pedagogik innovatsion texnologiyalar asosida didaktik usul bilan tatqiq qilish. Ushbu maqsadni amalga oshirish uchun:

- Taqqiqotni aniq asoslash;
- To‘g‘ri pedagogik texnologiyani tanlash;
- Maqola dolzarbligini innovatsion tatqiqotlash zarur.

Mavzuning pedagogik ahamiyati haqida so‘z borganda, an‘anaviy energiya (hozirda foydalanib kelinayotgan barcha turdagi energiya ishlab chiqarish)ning sezilarli darajada resurs va ekologik cheklovlari bilan yonilg‘i va energetikaga bo‘lgan dunyo talabining o‘ssishi, o‘sib boradigan va qazib olinadigan yoqilg‘ining iste‘molini barqarorlashtiradigan energiya ehtiyojlarining muhim qismini olishga qodir bo‘lgan yangi energiya texnologiyalarini o‘z vaqtida tayyorlashni talab qiladi. Ushbu texnologiyalarga yangi yadro texnologiyalari va atom energetikasining (1-rasm) afzalliklarini tarqatish va bugungi kunda unga xos bo‘lgan kamchiliklardan xoli etish vazifasi yuklatilgan. [2].

⁵ O‘zbekiston Respublikasi Prezidenti PQ-4623 2020 yil 27 fevral qarori www.lex.uz



1-rasm. Atom elektr stansiyasi ko'rinishi.

IAEA-ning yadro xavfsizligi bo'yicha harakatlar rejasi davlatlar va boshqa tegishli tashkilotlar (xususan, Butun jahon yadro assotsiatsiyasi, Xalqaro yadro agentligi, Yevropa yadro tadqiqotlari tashkiloti, Yadro energetikasi agentligi va boshqalar) tomonidan amalga oshiriladigan yadro xavfsizligi infratuzilmasini mustahkamlashning asosiy elementidir. Tinch atom energetika ob'ektlarini ishlatish xavfi to'g'risida davom etayotgan munozaralarga qaramay so'nggi yillarda jahon atom energetikasining rivojlanishi ijobiy tendentsiyalar bilan ajralib turadi [3]. Bu xususan ko'plab mamlakatlarda yangi reaktorlarning faol ravishda qurilishi va mavjud modernizatsiya qilinishidan dalolat beradi. Bugungi kunda atom energiyasi dunyoda ishlab chiqarilayotgan elektr energiyasining 11.5 foizini tashkil etadi va "Xalqaro energetika" agentligining prognozlariga ko'ra uning ulushi barqaror o'sib borayapti. Shuning uchun ham atom energetikasi istiqbolli yo'nalishlardan biri bo'lib qolmoqda. An'anaviy energiya manbalari bilan taqqoslaganda atom energetikasi yuqori mahsuldorlikka ega (xususan yadro yoqilg'isi) issiqlik effektini yaratmaydi, chunki bu ekologik talablar bo'yicha energiya ishlab chiqarishning eng toza usuli hisoblanadi. Har yili Yevropadagi atom elektr stansiyalari 700 million tonna CO₂ emissiyasining (2-rasm) oldini oladi, yoqilg'ini qayta ishlatish imkoniyati mavjud (yangilanishdan keyin).dunyoda atom energiyasidan foydalanishning maqsadga muvofiqligiga ishonch sezilarli darajada o'sdi [4].

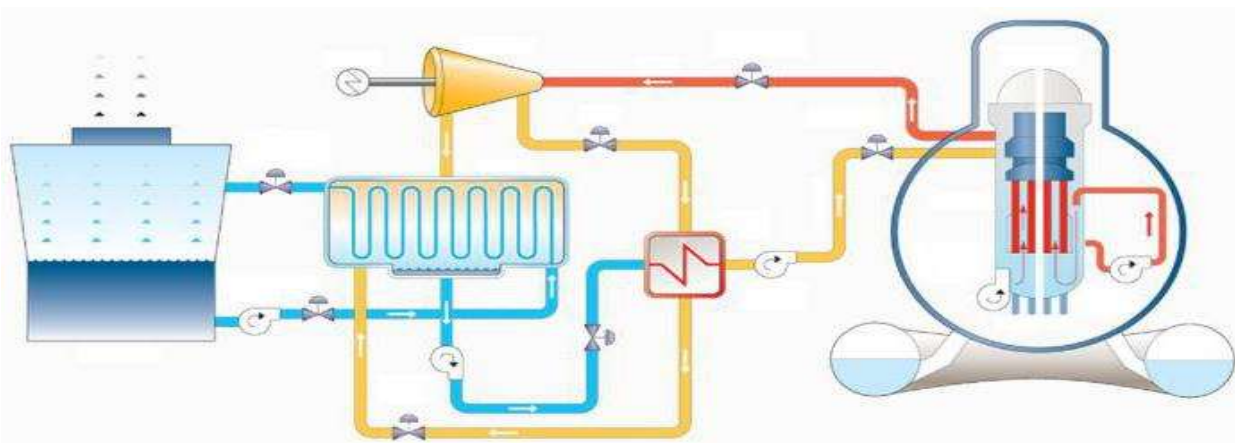

2-rasm. Yadro(Atom) reaktori ishlashi printsipi.

Biroq, bir qator mamlakatlar mavjud bo'lgan va yangi atom elektr stantsiyalarini qurishdan bosh tortganiga qaramay, dunyo atom energetikasi rivojlanishida ijobiy tendentsiyalar mavjud. Xususan, Osiyo va Sharqiy Yevropaning bir qator mamlakatlari barqaror iqtisodiy o'sishga, energetik xavfsizlikka va chiqindilar va karbonat angidrid (CO₂) miqdorini kamaytirishga intilib, kelajakda atom energetikasini rivojlantirishni davom ettirmoqdalar. Atom energetikasini keng miqyosda rivojlantirish rejalari bir qator sabablarga bog'liq: dunyo aholisining doimiy ko'payishi va ishlab chiqarishni jadal sanoatlashtirish hisobiga energiya resurslariga bo'lgan talabning o'sishi; tovar bozorlariga kirish uchun raqobatning kuchayishi; an'anaviy energiya tashuvchilar zaxiralarining to'liqligi va ular uchun narxlarning muqarrar ko'tarilishi, shuningdek neft va gaz eksport qiluvchi mamlakatlarda siyosiy beqarorlik; atrof-muhitni global isishga olib keladigan zararli gazlar, chiqindilar nuqtai nazaridan himoya qilish zarurati, tashqi omillardan mustaqil ravishda energiya ta'minoti resurslarini yaratish istak paydo bo'la boshladi [5].

Shu bilan birga sohaning rivojlanishiga sezilarli darajada to'sqinlik qiladigan ob'ektiv omillar mavjud. Bundan tashqari, atom energetikasining xavfsizlik muammolarini uning insonga va atrof-muhitga ta'siri nuqtai nazaridan ham, ishlatilgan yadro yoqilg'isiga ishlov berish muammosini ham hal qilish zarur. O'tkazilgan ilmiy ishlarning tahlili shuni ko'rsatadiki, olimlar "Atom energiyasining kelajagi tugagan yadro yoqilg'isini qayta ishlaydigan tezkor reaktorlarsiz tasavvur qilib bo'lmaydi" degan fikrda. Ular uran zaxiralaridan yanada samarali foydalanishga va atrof-muhitni muhofaza qilish muammolarini hal qilishga imkon beradi.

2000-yillarning boshidan asosan Osiyo-Tinch okeani mintaqasidagi atom elektr stantsiyalarining keng miqyosli qurilishi tufayli atom energetikasi o'sib bormoqda. Dunyoda eskirgan atom elektr stantsiyalarining tez yopilishi qayd etilmoqda, sanoat ob'ektlari xavfsizligini davlat va xalqaro tartibga solish talablari kuchaymoqda. Qoldiq yoqilg'ilar (neft, tabiiy gaz va ko'mir) dunyoning aksariyat ehtiyojlarini qondirishda davom etayotgani inkor etilmasligi kerak chunki, boshqa energiya manbai hamyonbopligi, samaradorligi va ishlab chiqarish ko'lami bo'yicha ularga teng kela olmaydi. Shu bilan birga, qazilmaydigan yoqilg'ilar orasida energiya iste'molidagi atom energiyasining ulushi asta-sekin bo'lsa ham o'sib bormoqda. Butunjahon yadro assotsiatsiyasi 2016 yilda global atom energetikasi quvvati 2030 yilda 26,7 foizga (494 GVt gacha), 2035 yilda 40 foizdan (546 GVt) oshishini prognoz qilmoqda (yuqori stsenariy). Taxmin qilinishicha, 2050 yilda yadroviy potentsial 964 GVtni tashkil etadi va bu dunyo elektr ta'minotining 24 foizini ta'minlaydi. Uchinchi va to'rtinchi avlodlarning standart reaktorlariga, shuningdek tezkor reaktorlarga tezlashtirilgan o'tish tufayli atom energiyasining o'sishi mumkin [6].

Bugungi o'sib kelayotgan yosh avlodni tayyorlashda yadro energetikadan foydalanishni qanchalik to'g'ri tushuntirilsa rivojlanib borayotgan yurtimizga chiqindilardan xoli energiya ishlab chiqara olishimizga ishonтира olamiz. Har bitta

oliy o'quv yurtlarida shu yo'nalishda ish olib borayotgan professor o'qituvchilarimiz aniq maqsadga erishish uchun yadro energetikasini turli metodlar orqali tushuntirib borishmoqda (1-jadval). [7,8].

Bunga misol qilib, talabalar mavzu mohiyatini "Toifalash jadvali" orqali quyidagicha tushuntirish mumkin.

Jadvalni to'ldirishning qoidasi

1. Toifalar bo'yicha ma'lumotlarni taqsimlashning yagona usuli mavjud emas.

2. Bitta mini - guruhda toifalarga ajratish boshqa guruhda ajratilgan toifalardan farq qilishi mumkin.

3. Ta'lim oluvchilarga oldindan tayyorlab qo'yilgan toifalarni berish mumkin emas bu ularning mustaqil tanlovi bo'la qolsin.

1-jadval.

"Toifalash jadvali" metodini yadro energetikasi sohasiga qo'llanilishi.

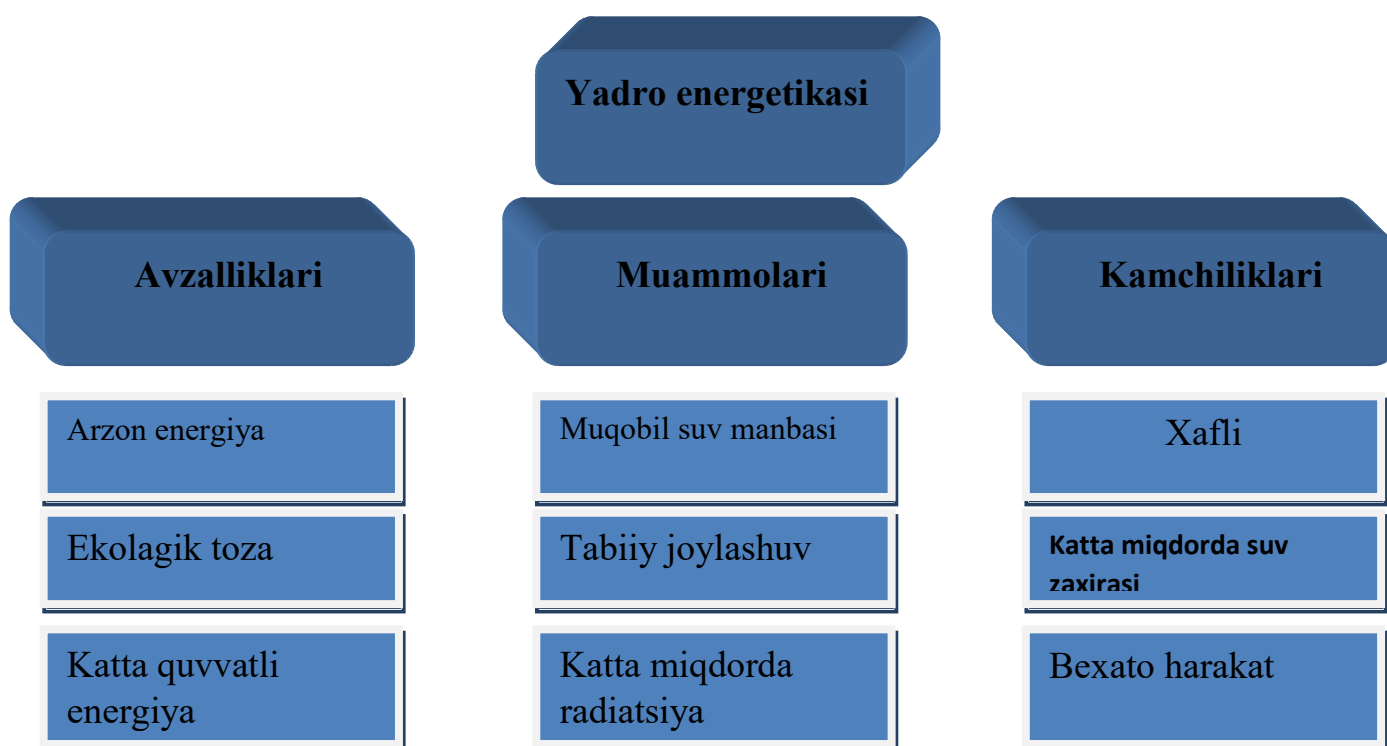

Mavzu mohiyatini talabarlarga aniq yetkazishimiz uchun. Ushbu metod samaradorligi juda yuqori. Hayotimiz juda ham tez raqamlashirish jarayonini boshidan kechirmoqda. shuni inobatga olgan holda har bitta muammoga yechim topish barobarida uni qanday qilib yetkazish muammolarini ham hal qilishimiz zarur. Yadro energetikasi O'zbekistonda eng yosh energiya manbasi hisoblanadi. Shuning uchun bu yo'nalish metodikasi yoritishda asosan Yevropa mamlakatlarning pedagoglar erishgan bu boradagi yutuqlarini to'liqligicha o'rganib uni talabalarga yetkazish maqsadga muvofiqdir. Har bir ilim

maskanlarida maqsad bitta: bozor iqtisodiyotiga mos raqobatbardosh kadrlar tayyorlash. Shu o'rinda Prezidentimiz Shavkat Mirziyoyev 2020 yilga belgilangan elektr energiyasini ishlab chiqarish, taqsimlash va etkazib berish bo'yicha chora-tadbirlarni to'liq va sifatli amalga oshirish zarurligini o'z nutqlarida ta'kidladilar.

Adabiyotlar ro'yxati:

1. O'zbekiston Respublikasi Prezidentining "Pedagogik ta'lim sohasini yanada rivojlantirish chora-tadbirlari to'g'risida"gi 2020 yil 27 febraldagi PQ-4623 sonli Qarori.
2. Ядерная энергетика. Учебное пособие; Азаренков Н. А., Булавин Л. А., Залюбовский И.И., Кириченко В. Г., Неклюдов И. М., Шилиев Б. А. – Х.ХНУ имени В. Н. Каразина 2012. 535 с.
3. Акатов А. А., Коряковский Ю. С. Будущее ядерной энергетики. Реакторы на быстрых нейтронах. — 2012. — 36 с.
4. Всемирная ядерная ассоциация: официальный сайт. Режим доступа: <http://www.world-nuclear.org/> Государственная корпорация по атомной энергии «Росатом»: официальный сайт. Режим доступа: <http://www.rosatom.ru/> Обзор ядерных технологий — 2016:
5. Безопасность ядерных энергетических установок. Самойлов О.Б., Усынин Г.Б., Бахметьев А.М. Москва, 1989
6. Доклад Генерального директора Международного агентства по атомной энергии (ИАЕА). — 70 с. — [Электронный ресурс]. Режим доступа:
7. Azizxujayeva N.N. Pedagogik texnologiyalar va pedagogik mahorat. T.: CHulpan. 2013. - 200 bet.
8. Hakimova M.F. Pedagogik texnologiyalar. O'quv qullanma. T.TDIU.,2013

Bozorov E.H.
professor
O'zbekiston Respublikasi Fanlar Akademiyasi
Yadro Fizikasi instituti f.-m.f.d.
Rustamov S.Sh.
ass.
Buxoro Muhandislik-texnologiya instituti
"Elektr mexanikasi va texnologiyalari"

**DUNYODA YADRO TEXNOLOGIYALARI RIVOJLANISH
BOSQICHLARINING PEDAGOGIK TAHLILLAR ORQALI
ASOSLASH**

Annotatsiya: Mamlakatda yadro texnologiyalar orqali nafaqat arzon elektr energiyasini olish va yadro texnologiyalaridan samarali foydalanish imkonini berishi hech kimga sir emas. Shuning bilan birga, yadroviy texnologiyalar energetika sohasiga taalluqli bo'lmagan sohalarda misol uchun: Inson salomatligi, qishloq xo'jaligi, oziq-ovqat maxsulotlarida ham qo'llash yuqori samara beradi desak mubolag'a bo'lmaydi. Zero, mamlakatda yadro texnologiyalaridan foydalanish yadroviy tibbiyot rivojlanishiga ham turtki bo'ladi. Yadro texnologiyalari fanini o'qitish esa talabalarga yadro texnologiyasidan oqilona foydalanish va mamlakatdagi sohaga oid manba'larni metodika orqali yetkazishdan iborat.

Kalit so'zlar: Yadro texnologiyalari, reaktor, radioaktiv, ionlash, atom, neytron, diagnostika, radioizotop, nurlanish, yadro tibbiyoti.

Bazarov E.J.
professor
Institute of Physics
Academy of Sciences of the Republic of Uzbekistan
Rustamov S.Sh.
acc.
"Electromechanics and Technology"
Bukhara Institute of Engineering and Technology

**JUSTIFICATION OF THE STAGES OF DEVELOPMENT OF
NUCLEAR TECHNOLOGIES IN THE WORLD THROUGH
PEDAGOGICAL ANALYSIS**

Annotation: It is known that the use of nuclear technology in the country will allow you to get cheap electricity. However, in areas where nuclear technology is not part of the energy sector, for example: in the use for human

health, agriculture and food, it is no exaggeration to say that the application will be very effective. The use of nuclear technologies in the country will also contribute to the development of nuclear medicine. Nuclear technology training will involve students in the intelligent use of nuclear technology and the provision of methodological resources to the country.

Keywords: Nuclear technologies, reactor, radioactive material, ionization, atom, neutron, diagnostics, radioisotope, radiation, nuclear medicine.

Mamlakatimizni ijtimoiy-iqtisodiy rivojlantirish bo'yicha ustuvor vazifalarga muvofiq kadrlar tayyorlashning mazmunini tubdan qayta ko'rib chiqish, xalqaro standartlar darajasida oliy ma'lumotli mutaxassislar tayyorlashga zarur shart-sharoitlar yaratish maqsadida O'zbekiston Respublikasi Prezidentining 2017 yil 20 apreldagi «Oliy ta'lim tizimini yanada rivojlantirish chora-tadbirlari to'g'risida»gi PQ-2909-sonli qarori qabul qilindi [1].

Mazkur qaror bilan oliy ta'lim darajasini sifat jihatidan oshirish va tubdan takomillashtirish, oliy ta'lim muassasalarining moddiy-texnika bazasini mustahkamlash va modernizatsiya qilish, zamonaviy o'quv-ilmiy laboratoriyalari, axborot-kommunikatsiya texnologiyalari bilan jihozlash bo'yicha Oliy ta'lim tizimini 2017 — 2021 yillarda kompleks rivojlantirish dasturi tasdiqlandi.⁶

Dunyoda yadro texnologiyalari rivojlanish bosqichlarining pedagogik tahlillar orqali asoslash mavzusini yoritishda har doim eng samarali metodni tanlash lozim, chunki innovatsion texnologiyalar talabalarda individual fikrlash, berilgan muammoga yechim topish va bu muammoga nisbatdan o'z fikrini bayon etib izohlashga qaratilgan. Mavzuni ochib berishda biz klaster metodidan foydalansak maqsadga muvofiq bo'ladi.

Klaster pedagogik ilg'or metod bo'lib maqsadni aniq belgilash va unga yechim topishga to'g'ri yo'l orqali harakatlar ketma-ketligida olib borish imkonini beradi.

Mavzuni dolzarbligidan kelib chiqqan holda pedagogik texnologiyani qanchalik aniq tanlasak mavzu muammolariga shuncha aniq yechim topamiz [2].

Tadqiqodning maqsadi:

- Dunyoda yadro texnologiyalari rivojlanish bosqichlarini pedagogik tahlillar orqali asoslash.
- Mavzuni yoritishda innovatsion pedagogik texnologiyalarning eng maqbul variantini qo'llash.
- Pedagogik texnologiyalar yordamida mavzu yuzasidan bilim va ko'nikmalarni aniq va ravon bayon etish.

Bugungi kunda yadroviiy texnologiyalar nafaqat qurol va elektr energiyasi, balki bu insonga taalluqli bir qator muammolarni hal qilish uchun yangi imkoniyatlar ekanini anglash mumkin. Yadro sanoatining tarixi radioaktivlik,

⁶ O'zbekiston Respublikasi Prezidentining 2017 yil 20 apreldagi «Oliy ta'lim tizimini yanada rivojlantirish chora-tadbirlari to'g'risida»gi PQ-2909-son qarori.

izotopiya, ionlashtiruvchi nurlanishning turli xil turlari, majburiy bo'linish, tabiiy radioaktiv elementlarni aniqlash, yangi texnogen elementlar va izotoplarni olish usullarini ishlab chiqish bilan boshlanadi. Bu borada yangi fanlar yadro fizikasi va radiokimyosiga barpo etish muhim ahamiyat kasb etadi [3].

Hozirgi kunda yadro texnologiyalari: yerda, yer osti, suv va suv ostida, havoda va kosmosda va hamma joyda yadro ishlaydi. Mamlakatimiz atom sanoati mutaxassislari mamlakatimizda faoliyat yuritib, import o'rnini bosishning zamonaviy sharoitlarida o'z yangi ishlanmalarini qanday amalga oshirish haqida fikr yuritmoqdalar.

O'tgan o'n yilliklar davomida bizning olimlarimiz, sanoatimiz va shifokorlarimiz inson hayotining muhim sohasida yadro texnologiyalaridan samarali foydalanish sohasidagi yutuqni amalga oshirish uchun zarur salohiyat to'plashdi. Mutaxassislar tomonidan yaratilgan texnologiyalar va ishlanmalar turli sohalarda keng qo'llanilmoqda. Misol uchun tibbiyot, qishloq xo'jaligi, oziq-ovqat sanoati, hosildorlikni oshirish uchun bug'doyni qayta ishlash texnologiyasi, bug'doyni saqlash muddatini ko'paytirish uchun urug'larda maxsus oldindan ishlov berish usullari mavjud. Bular mutaxassislar tomonidan yaratilgan va mahalliy rivojlanishga asoslangan.

(1-rasm)



Janubiy mamlakatlardan xushbo'y qalampir va boshqa ziravorlar ko'pincha turli xil infeksiyalarga moyil bo'lgan mahsulotlar keltiriladi. Yadro texnologiyalari barcha shunga o'xshash bakteriyalar va oziq-ovqat kasalliklarini yo'q qilishga imkon beradi.

Radiatsiya bilan davolash onkologiyada eng samarali usullardan biri bo'lib hisoblanib olimlarimiz hozirda bemorlarning davolanish darajasini oshirishga imkon beradigan turli xil eng yangi texnologiyalar ishlab chiqmoqdalar. Ilg'or texnologiyalar mavjudligiga



qaramay, bunday markazlar mamlakatning bir necha shaharlarida faoliyat ko'rsatmoqda. Bugungi kunda noyob yadroviy texnologiyalarni joriy etish jarayoni jadal davom etmoqda [4].

(2-rasm)

Nurlangan materiallarni qayta ishlash va izotoplarni ajratish bilan yadro texnologik siklining (YTS) energiya samaradorligini oshirish, odamlarning hayotini o'zgartirish imkonini berdi. Yadro tibbiyot sohasidagi shifokor va texnik xodimlar butun dunyo bo'ylab radioizotoplarni barqaror yetkazib berishga yoki radiofarmasevtik preparatlar va radiatsiya texnologiyasidan xavfsiz foydalanishga bog'liq bo'lgan, ko'plab proseduralarni amalga oshirdilar.

Yadrolarni noenergetik qo'llashning yana bir yo'nalishi texnologik o'simliklar ishlab chiqarish, qishloq xo'jaligi zararkunandalari va suv ta'minoti kabi mahsulotlarini ishlab chiqarish va qayta ishlash sohasida radioizotoplar va radiatsiya nurlanishidan foydalanish bilan bog'liq mintaqaviy izlanishlar hisoblanadi. Xalqaro atom energiyasi agentligi (radiologiya) barcha manfaatdor davlatlarga yadro bilimlarini aniqlash, baholash, rivojlantirish va yetkazib berishga ko'maklashish bilan shug'ullanadi. Osiyoda qishloq xo'jaligi ekinlari o'sishi (yashil inqilob) kabi texnologik ishlar natijalari keng ma'lum [5].

Bundan tashqari yadro texnologiyalari yadro reaksiyalaridan ionlashtiruvchi nurlanishdan foydalanishga imkon beruvchi muhandislik yechimlari to'plami hisoblanadi.

Yadro texnologiyalarining ba'zi yo'nalishlari:

- * Kimyoviy elementlarning yadrolarining energiya chiqarish bilan bo'linishi yoki birlashishi qobiliyatiga asoslangan texnologiyalar.

- * Ionlashtiruvchi nurlanishni olish va ulardan foydalanishga asoslangan texnologiyalar.

- * Kerakli xususiyatlarga ega bo'lgan moddalarni ishlab chiqarish uchun sanoatga xos texnologiyalar.

- * Yadro tibbiyot texnologiyalari.

- * Qishloq xo'jalik maxsulotlarini saqlash va himoyalash texnologiyalari [7].

Mavzuni ochib berishda talim oluvchilarga klaster metodi orqali tushuntirib berish fanga bo'lgan qiziqishlarini oshiradi va fikrini jamlashga yordam beradi.

«Klaster» metodi

Klaster metodi pedagogik, didaktik strategiyaning muayyan shakli bo'lib, u ta'lim oluvchilarga ixtiyoriy muammo (mavzu) lar xususida erkin, ochiq o'ylash va fikrlarni bemalol bayon etish uchun sharoit yaratishga yordam beradi. Mazkur metod turli xil g'oyalarni o'rtasidagi aloqalar fikrlash imkoniyatini beruvchi tuzilmani aniqlashni talab etadi. «Klaster» metodi aniq ob'ektga yo'naltirilgan fikrlash shakli sanaladi. Ushbu metod muayyan mavzuning ta'lim oluvchilar tomonidan chuqur hamda puxta o'zlashtirilguniga qadar fikrlash faoliyatining bir maromda bo'lishini ta'minlashga hizmat qiladi [8].

Guruh asosida tashkil etilayotgan mashg'ulotlarda ushbu metod guruh a'zolari tomonidan bildirilayotgan g'oyalarning majmui tarzida nomoyon bo'ladi.

Bu esa guruhning har bir a'zosi tomonidan ilgari surilayotgan g'oyalarni uyg'unlashtirish hamda ular o'rtasidagi aloqalarni topa olish imkoniyatini yaratadi.

Stil va stil g'oyasiga muvofiq ishlab chiqilgan «Klaster» metodi puxta o'ylangan strategiya bo'lib, undan ta'lim oluvchilar bilan yakka tartibda yoki guruh asosida tashkil etiladigan mashg'ulotlar jarayonida foydalanish mumkin.

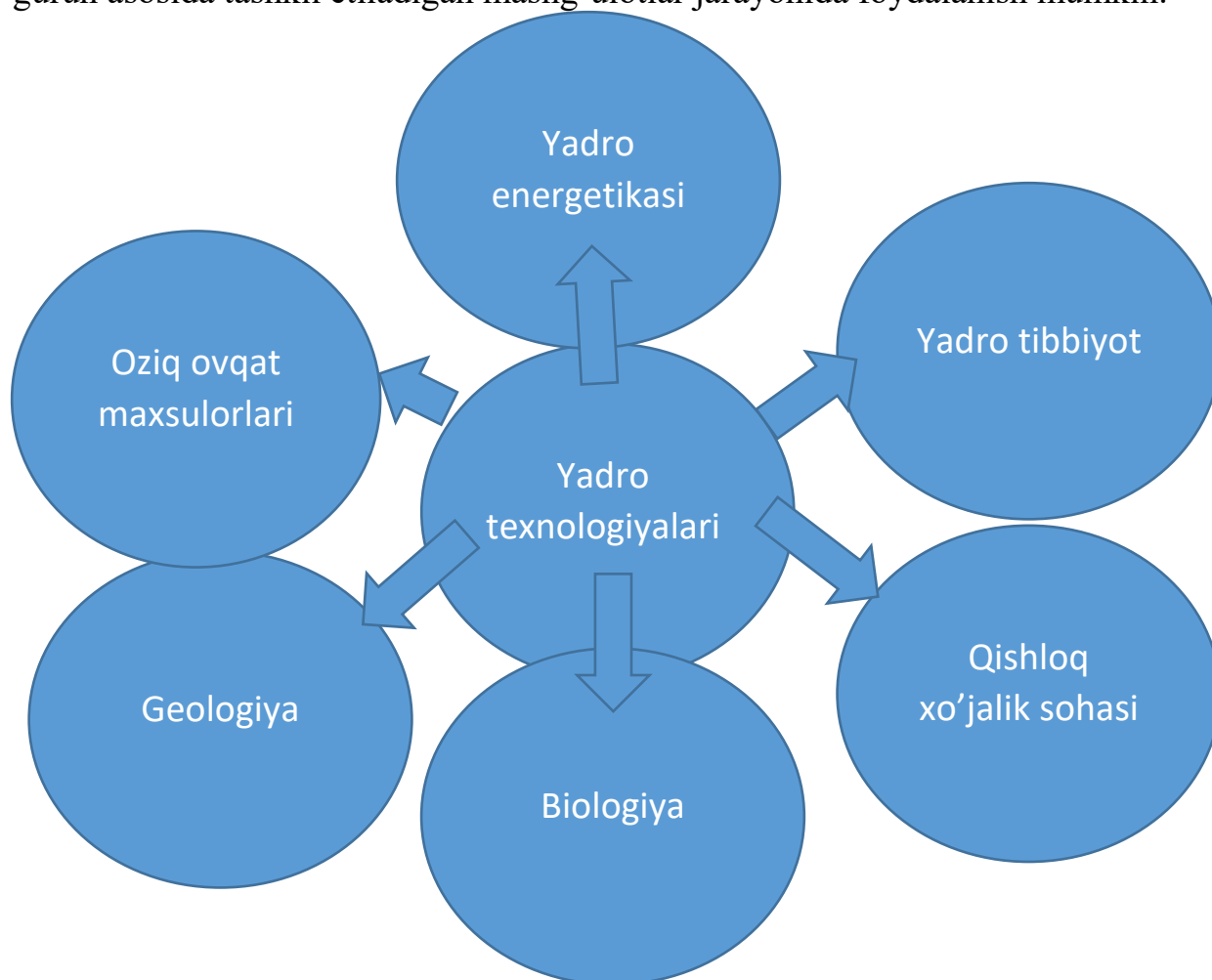

(3-rasm). Klaster metodi

Adabiyotlar ro'yxati:

1. O'zbekiston Respublikasi Prezidentining 2017 yil 20 apreldagi «Oliy ta'lim tizimini yanada rivojlantirish chora-tadbirlari to'g'risida»gi PQ-2909-son qarori
2. Azizxujayeva N.N. Pedagogik texnologiyalar va pedagogik mahorat. T.: SHulpan.2013. - 200 bet.
3. Апсэ В.А., Шмелев А.Н. Ядерные технологии: Учебное пособие. М:МИФИ, 2008. – 128 с.
4. Ядерные технологии: история, состояние, перспективы: Учебное пособие. / Андрианов А.А., Воропаев А.И., Коровин Ю.А., Мурогов В.М. - М: НИЯУ МИФИ, 2012. - 180 с.
5. Барсуков О.А. Основы физики атомного ядра. Ядерные технологии. М: ФИЗМАТЛИТ, 2011. — 560 с. — ISBN 978-5-9221-1306-9.
6. Родзевич А.П.Р60 Методы анализа и контроля веществ: учебное пособие /А.П. Родзевич, Е.Г Газенаур; Юргинский технологический

институт. Томск: Изд-во Томского политехнического университета 2013. – 312 с.

7. Ядерная энергетика: технология, безопасность, экология, экономика, управление: сборник научных трудов I Всероссийской научно-практической конференции молодых атомщиков Сибири; Национальный исследовательский Томский политехнический университет. – Томск: Изд-во Томского политехнического университета, 2010. – 260 с.

8. Hakimova M.F. Pedagogik texnologiyalar. O`quv qullanma. T.TDIU., 2013.

LIFE AND LITERARY HERITAGE OF ABDURAHMON TAMKIN BUKHARI

Annotation: This article is about the life and literary heritage of Abdurahmon Tamkin, a prolific poet, poet and one of the leading scholars of his time, who lived and worked in the late XIX and early XX centuries. Most of his works are written in Tajik, but there are some poems written in Uzbek and Arabic, which show that Tamkin is fluent in all three languages.

Methods: Comparative-typological, contextual analysis, biographical methods were used in the analysis of the life and literary heritage of Tamkin Bukhari.

Abdurahmon Tamkin Bukhari lived and worked in the late 19th and early 20th centuries he was a prolific writer, a brilliant poet, and one of the leading scholars of his time. Ahmad Donish Tamkin, an enlightened scholar of his time, was one of the great poets and praised his work. Shahin, Muztarib and Tamkin were the first poets of that time.

As for the first source:

"In the works of nineteenth-century writers such as Afzal Makhdumi Pirmasti and Haji Nematullo Mukhtaram, there is abstract information about the Bukhara poet Tamkin, or more precisely, misinformation that distorts the truth." Tajik scientist Askar John Fido writes [6, 3].

In fact, these comments do not provide accurate information about Tamkin. Because Tamkin's work has not been studied in Uzbek literature yet. We will try to address this issue as much as possible.

The second source is Tamkin's works, in which the poet makes some references to himself. If we keep these signs in our focus and look at the memory of the poet's students, we will find similarities and closeness. Because of this harmony, clarity about the poet's life and work can be achieved.

Jafarov, a student of the poet, played an important role in putting an end to various opinions about the life and work of A. Tamkin.

In Jafarov's writings: "Dar sanai 1905 melody (equivalent to 1322 AH) I studied in the garden of Bukhara, in the garden of Haji Makhdum. Alassaboh bo Hoji Mahdum ba hovlii domullo Abdurahmoni Tamkin raftem. Domullo was a humble and gentle man. Sinni sharifi eshon karib boi panjohu se rasida bud...". From this information it is clear that if the poet was 53 years old in 1905, it means that he was born in 1851-1852 in the Boyrabofi district of Bukhara. His father was Mulla Abdukhaliq. Tamkin lived in Bukhara. He was educated in Bukhara

madrassas and lived in his hometown, where he was very pleased to study science and described his peaceful life as follows:

*“Bihisht joi tu, Tamkin chi joi reb dar o’
Ki monda bog’chaye yodgor az padar ast”.*

Translation: “Paradise is your Tamkin, your door is the gate of heaven,
The garden here is a memorial to your father.”

Results and discussion. Boyrabofon neighborhood, where Abdurahmon Tamkin lived, is one of the largest guzars in Bukhara. This neighborhood was founded in 1846. However, the name of the guzar was Boriyabofon, and there was a mosque named after Haji Qurban. Boyrabofon mahalla is also called Besh kappa. Later, the guzar was named after the people who were engaged in weaving mats.

Boyrabofon mahalla was large and densely populated. They speak Turkish. The population of the mahalla is divided into two groups: Uzbeks from Khorezm in the southern part of the mahalla, and Turkmens from Charjoi in the northern part. They moved by order of King Murad. Shah Murad won a battle with the Khorezm khan and brought some of the Khorezmians to the city center, but due to lack of space, he gave them a place here due to the density of the population. Some Turkmen fled to Karakul district due to lack of space. Khorezmian and Turkmen Khidir-Hellenes used to live together. However, during the reign of Amir Alimkhan, each nation chose its own elder and was divided into two. Both groups are engaged in weaving. They also had their own bazaars in Guzar. Many residents of the neighborhood also did soap making.

According to 1927 reports, there were 107 farms in Guzar with a population of 420 people. In 1929, it merged with the neighboring Chorbakkoli gate Samarkand, Olim Khoja guzars and became known as Samarkand guzar.

Now this guzar is again called by its old name - Boyrabofon [1, 28-30]. Abdurahmon Tamkin Bukhari lived and worked in this neighborhood all his life and left a legacy of beautiful works and exemplary way of life to our people.

Tamkin taught at the Dorushshifo madrasah in Bukhara. It is known from the works of the poet that before he became a teacher, he was an imam and worked in the affairs of state. In the year 1315, Hazrat Zillil Alamin (Amir Abdulahad) became a member of the Ahl al-Fazlu Kamal Jirvapazir in the memory of the Prophet (peace and blessings of Allaah be upon him). *Bo hama vusuli ne'mat va ihsani kasir ba katar sar karda va amoratpanohon muvojib va atima az noni ehsani kasir bo shahdu shiri nomzad va khosog megardid*” [2, 8-9]. Molistan consists of 17 bytes, written in the form of an anthem to the Emir of Bukhara Abdullah Khan, and written in the continental genre. In addition, another hymn of Tamkin is dedicated to Abdullah Khan. The work is 71 bytes long and is called "Ganji shoygon" ("King of the Kings"). It was during these years that the poet believed that the causes of all oppression and ignorance were the amirs around him. He called on Amir Abdullah not to believe them and to be religious.

Ashkam az mijgon ba ro'yam obro'yam rext –rext,

Obro' barbod shud, durri nako'yam rext-rext [4, 11].

(Tears well up in my eyes,

My reputation was ruined, my dreams fell to the ground).

Amir Abdullah also paid close attention to the poet. However, due to the provocations of the people, the poet gradually lost sight of the Emir. No matter how much the poet expects blessings, the Emir will not get what he expects. Eventually, Tamkin's trust and asylum were replaced by endless hatred and he left the palace. He is so disappointed in his courtiers that he does not even want to face them. He even expressed this desire through a story in Moliston.

Tamkin's literary heritage is rich and prolific. He has created in all genres. For example, he wrote in qasida, ghazal, muhammas, qita, fard, chiston, problema and hajw. Most of his works are written in Tajik, but some of his poems are written in Uzbek and Arabic, indicating that Tamkin is fluent in all three languages. Through the work of A. Tamkin, a brilliant representative of the Bukhara literary environment of the XIX-early XX centuries, it is possible to say that the literature of this period reached the school level as a brilliant literature.

References:

1. Regional State Archive, fund 37, opis 1, case 9; delo 254 ..
2. Navodiri Ziyaiya. Signature No. 183, Gajinai Dastkhathoi East AFRSS Tajikistan.
3. Tamkin. Moliston. Signature throne number 337. I Sh. Own-n. Sheet 8-9.
4. Tamkin. Devon. Manuscript number. 111..
5. Tamkin. Ruboiyot. Yes. 32.

*Egamberdiyeva D.U.
teacher of department of languages
faculty of agrology and business
Andijan Branch of Tashkent State Agrarian University
Andijan, Uzbekistan*

PROBLEMS OF LEARNING DIALOGUE AND ITS STRUCTURAL COMPONENTS

Annotation: The article highlights the problem of learning dialogue and language, gives a detailed analysis of the structural components of dialogue and presents an original approach to learning language through dialogue.

Key words : dialogue, language, communication, structure, communicative move, communicative step, dialogical move, dialogical act, speech act.

Dialogue analysis is a young, developing area of scientific research, but it already has its own traditional directions.

Language is just one of the semiotic means by which people communicate with what surrounds them. The fact that a dialogical orientation in the humanities is inevitable is debatable. Interest in dialogical theory is growing in wide circles. We cannot say that a dialogical orientation has appeared until we understand what dialogue means. Experts agree and disagree about what the dialogical theory boils down to.

In many European languages, the term “dialogue” has different meanings. The Greek word *dialogos* comes from the verb *dialegethai* “to make a conversation,” which in turn is related to the verb *legein*, meaning “to speak, to speak,” and also to “gather.” Such an origin, expressed in a verb, can remind of “dialogue” as a process or practice, and not just an abstract thing.

The lively activity and rich palette of research works on the problems of dialogue testifies to the promise of its analysis. And even more important than quantitative dynamics is the fact that prerequisites for new, more specific theoretical and methodological research in some aspects are being discovered.

One of these aspects in the study of dialogue is the problem of articulating the dialogical text.

P.V. Zernetsky [3] distinguishes speech units of five levels: speech act, speech step, speech process, speech interaction and speech transaction. Under the speech step, he understands the minimum independent unit of speech activity, consisting of speech (s) act (s) with a single illocutionary force, and under the speech process - the speech (s) step (s) of the communicant from the moment of entering into communication to change the speaker. However, there is no clear functional and structural boundary between these terms: even in the definition, a

speech move is equated to a speech step. To understand what is important and what is secondary, we will give definitions to each phenomenon.

A dialogue is a conversation, an exchange of information between two people.

A speech act is the smallest unit of speech activity. Since a speech act is a type of action, then in its analysis, essentially the same categories are used that are necessary to characterize and evaluate any action: subject, goal, method, tool, means, result, conditions, success, etc.

The subject of a speech act - the speaker makes a statement, as a rule, calculated on the perception of his addressee - the listener. The statement acts simultaneously both as a product of a speech act and as an instrument for achieving a certain goal. Depending on the circumstances or on the conditions in which the speech act is performed, he can either achieve the set goal and thereby be successful, or not achieve it. To be successful, the speech act must at least be appropriate. Otherwise, the speaker will face communicative failure, or communication failure.

The communicative step is the minimum unit of dialogical communication, due to the general strategies and tactics of building a dialogue.⁷

A communicative move is a *functional and structural* unit, a unit of dialogical communication. Unlike communicative act (interactive) course is a verbal or nonverbal action of one of the participants, the minimum significant element, *developmental interaction* promoting the communication to the common communication target [5]. The communicative move can be verbal or non-verbal.

Communicative acts - are implemented, although not necessarily, through illocutionary acts - so in this unit combines the functions of element the "atom" of interaction and illocutionary: obvious attempt to give a speech act interactional and even inter-subjective content.

Dialogic unity is a combination of adjacent replicas, interconnected not only in meaning, but also structurally. The use of ready-made phrases usually associated with greetings, thanking, apologizing, congratulations, and so on. They give dialogical speech emotional.

The dialogical move is the largest monologue unit of dialogue. In accordance with the principle of hierarchical composition, a dialogical move consists of dialogic acts-steps.

The dialogic act, or step, is the minimum segment (relative in meaning) unit of dialogue.

Taking into account and analyzing all of the above, it becomes clear that **dialogue** is a large phenomenon, consisting of dialogical unity, which are a combination of the speaker's remarks, which in turn are subdivided into dialogical

⁷ Nosirova M.K. Formation of foreign language communicative competence of students in the framework of modular program. International scientific journal. Economy and society. № 6(73) -s.: 2020.

moves , implying the largest monologic units of dialogue. In turn, the dialogical move consists of dialogical acts or steps , which are the minimum segment (correlated in meaning) units of dialogue.

A communicative act is a conversation between people, the number of which may be different. In this case, we are talking not only about dialogue, but also about polylogue. In any case, the structure of the communicative act remains unchanged. But it is worth noting that the structure of the communicative act is different from the dialogical structure. A communicative act is a process of communication and exchange of remarks, which in turn is subdivided into *communicative moves* , that is, a *functional-structural* unit of communication, and moves consist of *communicative steps* , which represent the minimum unit of communication. Studying the dialogue, we, of course, focus not only on communication in general, but on *dialogical* communication.

If we consider a speech act , as any utterance of the speaker, then this definition can be understood as a communicative move, a communicative step, a dialogical move and a dialogical act. But among themselves, these phenomena are not identically equal. It can be concluded that the speech act is a means of communication in the communication of people.

Literature:

1. Nosirova M.K. Formation of foreign language communicative competence of students in the framework of modular program. International scientific journal. Economy and society. № 6(73) -s.: 2020.
2. Ф.А. Тиллабаева. С.Т. Жаббарова. Система работы по использованию словарей терминологического характера в учебном процессе в вузах. Научный электронный журнал. 2019., стр. 131-132.
3. Kiryigitov B., Nosirova M. Introduction & Purpose of the project: software facilities in translation. International conference., 2016, p.268.
4. Kiryigitov B., Nosirova M. Introduction & Purpose of the project: software facilities in translation. International conference., 2016, p.268.
5. Searle J.R. Classification of illocutionary acts // New in zarub, ling. Issue 17: Theory of speech acts. - М .: Progress., 1986. S. 170-194.
6. Edmonson JA Great expectation: an intensive self-analysis Text. / JA Edmonson, F. Plank // Linguistics and Philosophie 2., 1978. S. 373-413.

*Ergashev A.A.
assistant of the Department of Food Technology
Najmitdinova G.K.
assistant of the Department of Food Technology
Fergana Polytechnic Institute*

FEATURES OF DIFFERENTIATED TEACHING OF CHEMISTRY

Annotation: Till this day, the use of systematic and step-by-step education has been shown to increase lesson effectiveness and be understandable to students. It is also important that chemistry courses are organized on the basis of differentiated education. This article gives some information about it.

Keywords: chemistry stratification, stratification principle, stratified education.

*Ergashev A.A.
kafedrasi assistentlari
Najmitdinova G.K.
Farg'ona politexnika instituti oziq-ovqat texnologiyasi
kafedrasi assistentlari*

KIMYONI TABAQALASHTIRILGAN O'QITISHNING XUSUSIYATLARI

Annotatsiya: Bugungi kunga qadar tizimli va bosqichli ta'limning qo'llanilishi sababli dars samaradorligining oshishi, o'quvchilar uchun tushunarli bo'lishi isbotlangan. Kimyo o'quv kursini ham tabaqalashtirilgan ta'lim asosida tashkil etilishi juda muhim ahamiyatga ega. Mazkur maqolada shu haqda bayon etiladi.

Kalit so'zlar: kimyoni tabaqalashtirish, tabaqalashtirish tamoyili, tabaqalashtirilgan ta'lim.

Kimyo fanining mazmunini, kimyoviy tushunchalarni asta-sekin rivojlanib borishi asosida, ma'lum tizimga solinishining o'zi, kimyo fanini o'qitishda o'quvchilarni rivojlantiruvchi vosita bo'lib xizmat qiladi. Bu borada o'quv jarayonining faollik xususiyati ham muhim ahamiyatga ega. Kimyoning barcha bo'limlari birin-ketin rivojlanib boruvchi tushunchalar bilan o'zaro bog'langan bo'lib, bu ularni bir butun tizimga birlashtiradi. Kimyo kursida atom-molekulyar ta'limot, davriy qonun, anorganik va organik moddalarning tuzilish nazariyasi, elektrolitik dissotsilanish nazariyasi kabi ta'limotlarning qo'shilib borishi fan mazmunining tuzilishi rivojlantiruvchi ta'limda asos bo'lib xizmat qilishidan

dalolat beradi. Bu borada faqat kuchaytirilgan savollar yetarli bo'lmay, aniq ma'lumotlarni davriy ravishda umumlashtirish talab etiladi.

Umumlashtirish – bu fikrlash faoliyatining yuqori darajasidir. Qolgan barcha fikrlash usullari o'quvchilarni umumlashtirishni o'rgatishga tayyorlaydi. O'rganilgan ob'ektlar orasidagi bog'liqliklar izlansa, shunda umumlashtirish amalga oshadi. Umumlashtiriluvchi manba kimyoviy masalalar, qiziqarli ma'lumotlar yoki turli o'qitish metodlari bo'lishi mumkin. Eng qimmatli jarayon o'quvchilarning mustaqil ishlarida amalga oshirgan.

Ta'lim tizimida kimyo fanini o'qitishda maxsus umulashtiruvchi mavzular bor. Masalan, anorganik moddalarning asosiy sinflariga doir bilimlarni umumlashtirish, anorganik kimyoga doir bilimlarni umulashtirish, organik kimyoga doir bilimlarni umumlashtirish kabi mavzular o'tiladi va savoljavoblar, genetik bog'lanishga doir mashq va masalalar yechish orqali mustahkamlanadi. Bilishning oxirgi bosqichi umumlashgan bilimlarni aniqlashtirish va amaliyotga bog'lashdan iboratdir. Shuni ham yodda saqlash kerakki, nazariyaga haddan ziyod berilish, rivojlanishga olib kelmay, sxolastik tasavvurlarni shakllanishiga olib keladi. Kimyo ta'limida faol rivojlantiruvchi vositalarga quyidagilar kiradi:

- muammoli o'qitish;
- ko'rgazmali va texnik vositalardan keng foydalanish;
- bilimlarni tizimli nazorat qilish;
- mustaqil ishlarning har xil turlari;
- kimyoviy masalalar tizimi;
- o'quvchilarga differensial yondoshish.

O'quv jarayoning eng muhim vazifalaridan biri uning rivojlantiruvchi xususiyatga ega bo'lishidir. O'quv jarayoni o'zining rivojlantiruvchi vazifasini muvoffaqiyatli bajarish uchun, kimyoviy mavzularning mazmuni maxsus uslubiy ishlov berishni, o'quv jarayonini o'ziga xos tashkil etilib, har bir o'quvchining psixologiyasiga chuqur kirib borishni talab etadi. Rivojlantiruvchi ta'limning murakkabligi shundan iboratki, o'quvchilarning rivojlanishi har kimda alohida o'ziga xos xususiyatga ega bo'lib, ular bir xil natijaga turli yo'llardan boradi va bu yo'llar turlicha vaqt talab etadi.

Kimyo o'quv fanining mazmunini sistemali yozilishi ham kimyoni o'rganishda o'quvchilarni rivojlantirish vositasi bo'lishi mumkin, chunki uning asosida kimyoviy tushuncha va bilimlarning bosqichma – bosqich rivojlantirish yotadi, shuningdek o'quv jarayonining faolligi ham rivojlantirish vositasi bo'la oladi. Sistemalilik maktab kimyo kursi dasturida aniqlangan bo'ladi va u sinfdan sinfga tomon o'quvchilarning rivojlanish darajasi oshishini ko'zda tutadi, o'quvchilarning moddalar va ularning o'zgarishlari to'g'risidagi tassavurlarni boyitib borilishi quyidagicha yondashadi.

Kimyo kursining nazariy masalalarini bunday kuchaytirilishi bilimlarni sistemali shakllanishiga sharoit yaratadi. Kimyo o'qituvchisi o'quvchilarni umumlashtirish ko'nikmasini shakllantirishi zarurdir. Misollar keltiramiz, kimyoviy reaksiyalarning sinflari, jarayonlarning belgilari, anorganik moddalar

sinflari orasidagi genetik bog'lanishlar, organik moddalar orasidagi genetik bog'lanishlar va har bir mavzuga doir bilimlarini umumlashtirish talab etiladi. Bulardan tashqari rivojlantiruvchi o'qitishga sharoit yaratuvchi vositalarga o'quv jarayonini faol olib borish, muommoli o'qitish, ko'rgazmalilik asosida dars o'tish, o'quvchilarga differensial yondashish va boshqalar kiradi.

Differensial yondashish shundan iboratki, har bir o'quvchining o'ziga xos xarakteri, bilim darajasiga qarab turli topshiriqlar, beriladi. Ma'lum mavzu bo'yicha beriladigan savollarning qiyinchilik darajasi ortirib boriladi. O'quvchilar birinchi navbatda qiyinroq savollarga javob berishga harakat qiladi. Javob topish uchun adabiyotlardan foydalanadi. Dars jarayonida o'quvchilarning rivojlantirishning eng muhim zamonaviy vositalari va metodlariga muommoli o'qitish, axborot va innovatsion texnologiyalar kiradi.

Differensial yondoshuvning ma'nosi shundan iboratki, o'quvchilar ma'lum metodlar va didaktik vositalar asosida ularning o'zlashtirishi hamda rivojlanishiga imkon beruvchi guruhlariga ajratiladi (tabaqalashtiriladi). Differensiatsiyalash har xil xususiyatlarga qarab amalga oshirilishi mumkin. Ko'pincha o'qituvchilar sinf ichida o'zlashtirish darajasiga qarab tabaqalashtirishdan foydalanadi. Differensiyalash mavzularni mustahkamlash, takomillashtirish, natijalarni nazorat qilish hamda mustaqil ishlarni tashkil etish jarayonlarida yaqqol namoyon bo'ladi. Yangi mavzularni tushuntirishda agar butun guruh o'zlashtirish darajasi bir-biriga yaqin o'quvchilardan shakllantirilgan bo'lsagina saviyasiga ko'ra differensial yondoshuvni amalga oshirish mumkin. Masalan, fanni chuqurlashtirib o'qitiladigan guruhlar yoki oddiy guruhlar (yoki past o'zlashtiruvchilar).

O'qituvchi differensial yondoshuvni amalga oshirishda har xil guruhlar uchun murakkablik darajasi turlicha bo'lgan topshiriqlarni tanlab olishga harakat qiladi. Bu jarayonda ko'pchilik o'qituvchilar tomonidan bir xatolikka yo'l qo'yiladi. Past o'zlashtiruvchi o'quvchini yengil topshiriqlar berish yo'li bilan o'rgatish mumkin, lekin bu bilan uning aqliy rivojlanishini sekinlashishiga ham sabab bo'lish mumkin. Bundan tashqari yengillashtirilgan topshiriqni yuqori baholash, o'quvchining o'z bahosini noto'g'ri talqin qilishiga olib kelishi mumkin. Bu hol qolgan o'quvchilarga nohaqlikdek ko'rinishi natijasida ularning darsga va fanga bo'lgan qiziqishlari susayishiga olib kelishi mumkin. Bunday vaziyatdan chiqish uchun Latviyalik metodist I.Ya.Trepsh qiyinlik darajasi ortib boruvchi topshiriqlardan foydalanishni tavsiya etadi. Savollar qiyinlik darajasi ortib borish tartibida tuziladi. Birinchi savolga javob berish uchun faqat reproduktiv (esda saqlab qolgan) javob, ikkinchisi uchun taqqoslash, uchinchisi uchun o'zaro bog'liqliklarni analiz (tahlil) qilish, to'rtinchisi uchun bilimlarni umumlashtirish hamda keng ko'lamlil bog'lanishlarni aniqlash kerak bo'ladi. Baholash jarayoni ham yengillashadi hamda haqqoniy ravishda amalga oshadi.

Foydalanilgan adabiyotlar:

1. O'tkir zehnlilar kitobi. B.Akbarov, M.Primqulov. Toshkent "O'zbekiston"-2015.

2. Fayzullaeva D.M., Ganieva M.A., Ne‘matov I. Nazariy va amaliy o‘quv mashg‘ulotlarda o‘qitish texnologiyalari to‘plami / Met.qo‘ll. O‘rta maxsus, kasb-hunar ta‘limida innovatsion ta‘lim texnologiyalari seriyasidan – T.: TDIU, 2013.
3. Ro‘zieva D., Usmonboeva M., Holiqova Z. Interfaol metodlar: mohiyati va qo‘llanilishi / Metod.qo‘ll. – T.: Nizomiy nomli DTPU, 2013.
4. Avliyakov N.X., Musaeva N.N. Modulli o‘qitish texnologiyalari. – T.: —Fan va texnologiyalar nashriyoti, 2007
5. www.ziyonet.uz

*Fayazov O.A.
the Ministry of Innovative Development
of Uzbekistan
Kadirova R.A.
the Ministry of Innovative Development
of Uzbekistan*

THE IMPACT OF DECENTRALIZATION OR DELEGATION OF AUTHORITY ON THE REGIONAL DISPARITY

Abstract: this research aims to identify the correlation between decentralization and regional disparity and assess the possible effect of decentralizing governance for reducing the level of regional disparity in Uzbekistan.

Index terms: Decentralization, delegation, authority, governance, regional disparity, administration.

Recently, the decentralization process has become one of the most be discussed political and economic issues. A lot of developing countries have initiated or considered to initiate, on some shapes of transfer of political power to local authorities (Dillinger, 1994). Not coincidentally, almost simultaneous transformations were defined as “management revolution”. The search for new approaches to the organization of the public administration system led to the abandonment of the traditional type of managerial rationality (in its classical, Weberian interpretation) and the actualization of the processes of self-organization and self-management of social systems, and also increase the social efficiency of public administration. Modern concepts of new public management (‘new public management’) and management (‘governance’) focus on high effectiveness of public administration, political pluralism in the decision-making process, delegation of authority to lower levels of the management hierarchy, more balanced distribution of power, responsibility and accountability, development and expansion of civic participation (Trofimova, 2011).

In decentralization the main task of the government is to provide local communities with the opportunity to independently solve their problems and control the quality of public services provided. This approach is consistent with the core values of the local self-governance - autonomy (decentralized governance), democracy (civic participation) and efficiency (proximity of power to the population). State transfers public service functions non-governmental (commercial and public) organizations, reserving the functions of control and development of a common strategy.

According to Armstrong & Taylor (2000) there are plenty of reasons which might describe the augmenting interest in decentralization. The belief that

decentralization can effectively increase efficiency of public finance is the first reason. The second one is against reaction to the centralized bureaucratic processes not only developing countries, but also in OECD countries. The third is the demand for democratic reforms which might encourage public participation in social-economic policy and administration.

Nevertheless, there are many contradictions in explanation of outcomes of decentralization, because the assessment itself relies on political, social and economic factors. For instance, some authors (Zhang & Zou (1997), Freinkman & Yossifov (1999), Lin & Liu (2000)), who had made national research about the correlation of decentralization and regional growth, came to conclusion that decentralization had a positive effect on economic development in India, China and Russia, whereas Zhang & Zou (1998) and Xie, Zou, & Davoodi (1999) have concluded the opposite for the USA and China. But all the scholars have come to one agreement that the initial factor of the decentralization is a good “quality” of the local government and elaborated implementation steps. As Olum (2014) stated, “Decentralization cannot be successful in developing countries if it is implemented without the establishment of proper planning and accountability mechanisms. Short of these measures, decentralization can reallocate power and resources in a way that leads to power struggles and renewed conflict, an occurrence that is counterproductive to the very essence of decentralization”.

Torissi et al. (2015) described how devolutionary process operates and its impact to the regional disparity in Italy, but the scheme can be considered as a general description (Figure 6). Decentralization, by vicinity to the citizens and strengthened accountability of local administrations, accompanied by a developed social structure and civil society, obliquely promotes socioeconomic progress and spawn aggregate and self-reinforcing appearance, in which economic dynamism raises its validity and thus feeds back into the devolutionary push (Calamai, 2009).

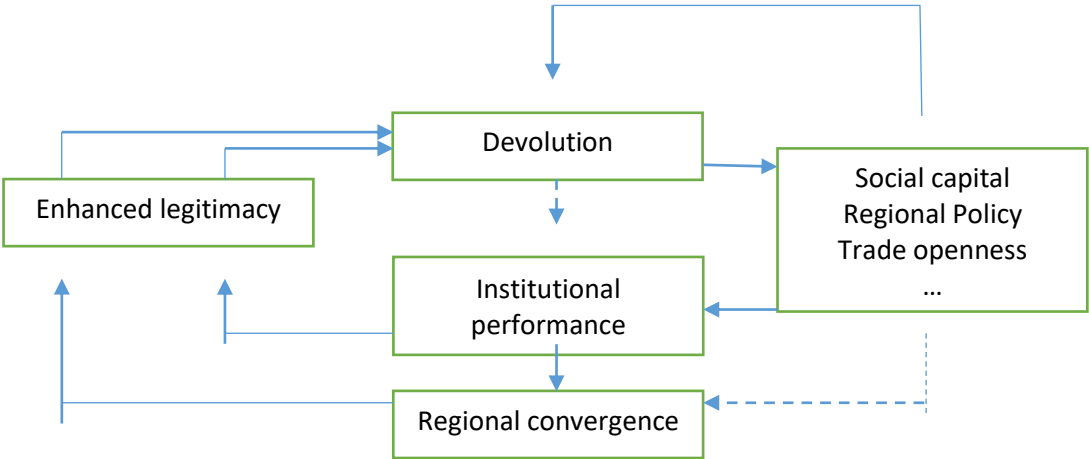

Figure 1. Link between devolution and regional disparities in Italy.

In addition, the relationship between the level of economic development and the degree of fiscal decentralization of its fiscal system, as a essential part of

whole decentralization process, is obvious. It is expressed in the following trend: the higher the degree of fiscal decentralization in the region and the municipality, the higher their level of economic development. A positive correlation has also been established between the degree of fiscal decentralization in the region, per capita tax revenues and the level of economic development.

The government of Uzbekistan and state administrative bodies are characterized by a high degree of centralization. Main problems about government accountability and transparency remain in spite of gradual changes. The President and the Cabinet of Ministers possess powers, and the system which empowers ministries and local authorities is limited.

Today Uzbekistan is actively discussing plans to introduce the practice of developing regional development strategies using the tools of integrated planning and active involvement in the planning process of representatives of local authorities and the private sector.

According to UNDP, the integrated programs and projects would subsequently allow to combine the most important tasks for socio-economic and environmental development in one systematic document, namely in the development strategy of the region. On the one hand, it will make it possible to reduce existing sectoral programs developed at the central level, on the other, it will increase the role of local authorities in planning the development of regions taking into account the interests and needs of each region.

Such an integrated approach in local development will further allow achieving rational distribution and efficient use of resources, creating new jobs and increasing incomes of the population, providing affordable and high-quality social services for health care, education, etc. The regional development strategy provides an opportunity to link a comprehensive picture of the available human, material and production resources with the most important socio-economic tasks at the local level, and to determine the development priorities of the region for the medium and long term.

Thus, mutually beneficial cooperation of local government bodies, business entities, NGOs and other civil society institutions aimed at achieving the goals and solving specific tasks of a specific region of an economic, social or environmental nature will enhance the legitimacy of the adopted policy measures and which means national prosperity.

References:

1. Dillinger, W. (1994). Decentralization and its Implication for Urban Service Delivery. Urban Management Programme Discussion Paper No.16.
2. Trofimova, I. N. (2011). Трансформация отношений центральной и местной власти в процессе децентрализации управления (опыт европейских стран) / Transformation of relationships between central and local government in the process of management decentralization . Ars Administrandi.
3. Armstrong, H., & Taylor, J. (2000). Regional Economics and Policy.

4. Zhang, T., & Zou, H. (1997). Fiscal decentralization, the Composition of Public Spending, and Regional Growth in India. Development Research Group Working Paper.

*Gulomjonova M.
teacher of department of foreign languages
faculty of agro engineering and hydro melioration
Andijan Institute of Agriculture and Agro technologies
Uzbekistan, Andijan*

THE ROLE OF DISTANCE LEARNING IN THE ORGANIZATION OF INDEPENDENT COGNITIVE ACTIVITY OF STUDENTS

Abstract: Distance education is increasingly associated with a closed learning system, in which the main means of communication, learning and information transfer is INTERNET. Developed in 1991, Web technology is becoming the environment where distance learning fits in most naturally and effectively, not excluding the use of FTP, e-mail, etc.

Keywords: distance learning, individual learners, Web technology, foreign language, language learning, knowledge.

The analysis of the main pedagogical methods of modern education based on computer and telecommunication technologies shows that the content of pedagogical activity in the new educational system differs significantly from the traditional one. This requires specific knowledge, skills, and abilities from the teacher.

First, course development activities become much more complex as their technological basis is rapidly evolving. It requires the teacher to develop special skills, methods of pedagogical work. In addition, modern information technologies put forward additional requirements for the quality of the developed educational materials, mainly due to the openness of access to them for both a large number of trainees and teachers and experts, which in essence enhances control over the quality of these materials.

Secondly, the peculiarity of the modern pedagogical process is that, unlike traditional education, where the teacher is the central figure, the center of gravity, when using new information technologies, is gradually shifted to the student (learner), who is actively building his educational process, choosing a certain trajectory. in a developed educational environment.

In these conditions, the most important function of the teacher is to support the student in his activities: to promote his successful promotion, help in finding and mastering the necessary information, to facilitate the solution of emerging problems.

Thirdly, the provision of educational material in modern education requires more active and intense interactions between students than in a traditional classroom, where generalized feedback of the teacher with the whole class

prevails, and the interaction of the teacher with an individual student is rather weak.

Thus, in connection with the use of modern computer and telecommunication technologies in the field of education, there are significant changes in teaching activities, the place and role of the teacher in the educational process, its main functions. The following changes can be noted as the primary functions:

- complication of course development activities;
- the need for special skills and techniques for developing training courses;
- strengthening the requirements for the quality of educational materials;
- increasing the role of the student in the educational process;
- strengthening the student support function;

Significant changes are taking place in teaching due to the use of new information technologies in the distance education system. If in traditional education the teacher devoted most of his time to lecturing, now the teacher must:

1. To develop the content of the course on a new technological basis.
2. To help the student navigate through the vast and varied educational information and find a suitable educational trajectory for him.
3. Ensure active interaction of the trainee both with the teacher himself and with other trainees during the discussion of the course issues.

Each of these core teaching activities has specific challenges. Thus, the development of courses based on new technologies requires not only fluency in the subject and its content, but also special knowledge in the field of modern information technologies. Thus, in the course of the educational process, not only special pedagogical, but also technological skills, experience of working with modern technical means are needed.

A characteristic feature of education management based on new information technologies is the organization of the educational process based on the division of labor. Without it, it is impossible to achieve a significant increase in the number of students, and hence the manifestation of economies of scale, i.e. increasing the efficiency of the educational system due to economies of scale of its activities.⁸

The economies of scale are one of the main sources of increasing the efficiency of the new educational system, the formation of which requires significant expenditures on the formation of its technological base. Not a teacher of the old educational system, equipped with new technical and technological means, but a teacher of a new specialization with its inherent nature of activity and place in the general system of division of labor can ensure the effective functioning of the distance learning system.

⁸ Egamberdiyeva D.U. The account of individual features of students in the process teaching english language. International scientific journal. Economy and society. № 6(73) -s.: 2020.

Thus, the organization of teaching activities based on the division of labor is an integral part of the management of the modern educational system, which is carried out on the basis of a systematic approach to the processes of its development.

As follows from the above analysis of the content of pedagogical activity in the distance learning system based on new information technologies, the main specializations of teachers in this system are as follows:

- course development specialist, i.e. course designer;
- facilitator - a specialist who helps students find and implement their educational trajectory in the developed educational material;
- a tutor is a specialist in the interactive delivery of training courses, interaction with students during the study of course materials;
- specialist in methods of monitoring learning outcomes, responsible for organizing and conducting tests, tests, exams.
- the possibility of teacher feedback with each student.

Accessibility and openness of education is another of the main advantages of DL. Distance learning provides us with the opportunity to study remotely from the place of study, without leaving our home or office. This allows a modern specialist to study almost all his life, without special business trips, vacations, combining with the main activity. Studying anytime, anywhere allows students not only to stay in their familiar environment and maintain their usual rhythm of life, but also to develop an individual training schedule. At the same time, focusing on training in the evening and on weekends.

Distance learning is recognized as one of the cheapest ways to get education, primarily by reducing the cost of moving, living in another city, reducing the cost of organizing the courses themselves (no need to pay for the classroom, fewer attendants, the cost of teachers can be reduced etc.).⁹

Another advantage of distance learning is access to quality education. The freedom and flexibility of this way of acquiring education offers new opportunities for choosing a course of study. It is very easy to choose several courses from different universities, from different countries. You can study at the same time in different places by comparing courses with each other. There is an opportunity to study in the best educational institutions, using the most effective technologies, from the most qualified teachers. A person can study remotely incognito, due to various reasons (age, position, position, shyness, etc.). Distance learning provides an opportunity to get education for people with disabilities and people with various disabilities.

As practice shows, when using distance learning, an educational institution receives a larger number of foreign students, universities have the opportunity to increase the number of students by attracting distance students from other countries and cities.

⁹ Egamberdiyeva D.U. The account of individual features of students in the process teaching english language. International scientific journal. Economy and society. № 6(73) -s.: 2020.

DL is more individualized in nature. The student himself determines the pace of learning, can return several times to individual lessons, skip individual sections, etc. The listener studies the educational material during the entire study period, and not only during the session, which guarantees deeper residual knowledge. Such a training system forces the student to study independently and acquire self-education skills. As the experience of many universities shows, a distance student becomes more independent, mobile and responsible. Without these qualities, he cannot learn. If they did not exist initially, but the motivation for training is great, they develop and upon completion of the training specialists come out who are really in demand on the market. Distance learning makes the learning process creative and individual, opens up new opportunities for the student's creative self-expression.

During the learning process, the student documents the learning process. He can have the course itself, e-mails with the teacher and he can refer to them later, as needed.

Using modern technologies and distance learning, we are given the opportunity to easily form virtual professional communities (for example, communities of teachers), communicate among teachers, discuss problems, solve common problems, exchange experience, information, etc.

One of the main disadvantages of distance learning is the lack of direct face-to-face communication between students and the teacher. When there is no person nearby who could emotionally color knowledge, this is a significant disadvantage for the learning process.

Distance learning imposes a number of its own requirements on the organization of the educational process, such as the need for a personal computer and Internet access, high requirements for setting the task for training, process administration, organization of student motivation. Distance learning requires tough self-discipline, and the result directly depends on the independence and consciousness of the student. As a rule, students feel a lack of practical training. There is no constant control over students.

List of used literature:

1. Egamberdiyeva D.U. The account of individual features of students in the process teaching english language. International scientific journal. Economy and society. № 6(73) -s.: 2020.
2. Majidova Z.A. The cognitive aspect of using phraseological units in teaching translation. International scientific journal. Economy and society. № 6(73) -s.: 2020.
3. Usmonova Sh. Study of scientific technical transfusion in non-linguistic educational university. International journal. Moscow.2019.
4. Matkarimova G. Formation of the english scientific competence in students of non-factual faculties. International journal. Moscow.2019.

*Haknazarova Z.U.
21 school teacher of English language
Jizzakh region, Sharaf Rashidov District*

AMERICAN HOLIDAYS AND TRADITIONS

Abstract: the article tells about holidays and traditions in the United States of America. The so-called legal holidays include Christmas, New Year's Day, Martin Luther King Day, President's Day, Memorial Day, Independence Day, Thanksgiving and others.

Key words: customs, traditions, holiday, ceremonies, sweets, families, celebrations, presents, religious holidays.

American Holidays is an introductory survey of the historical and social background of American holidays. People in every culture celebrate holidays. Although the word "holiday" literally means "holy day," most American holidays are not religious, but commemorative in nature and origin. Because the nation is blessed with rich ethnic heritage it is possible to trace some of the American holidays to diverse cultural sources and traditions, but all holidays have taken on a distinctively American flavor. In the United States, the word "holiday" is synonymous with "celebration! "

Christmas is a religious holiday celebrated on the 25th of December. On this day Americans celebrate the birth of Jesus Christ and sing Christmas carols. Another important tradition is sending Christmas cards. People start sending cards to their relatives and friends early in December. Going home for Christmas, is another good tradition. Christmas is considered to be a family celebration and every person must come back home on this day. This means that at Christmas, American houses are full of aunts, uncles, cousins and other relatives who might not see each other for a year. Americans put up a Christmas tree and decorate it with toys and sweets. There are religious ceremonies at churches on Christmas Day and families usually attend them. The Christmas table is very big. You can see turkey, ham, sweet potatoes, pies and other food. In the morning children hurry to the Christmas tree to look for presents. They hang big colourful socks for Santa Claus to put presents inside. Everybody starts unwrapping presents and thanking each other.

New Year's Day is celebrated on the 1st of January, but Americans begin celebrating it on the 31st of December. There is a big celebration in Times Square in New York City on this day. New Year's Day is not as widely celebrated as Christmas. On January 1 Americans visit friends, relatives and neighbours. There are parties and a lot of food. People watch television together and write New Year's resolutions. Throughout the country, parties are traditionally thrown on New Year's Eve, Dec 31st, to bring in the New Year. Times Square, in New York

City celebrates with a giant ball drop, which is broadcast all over the world. At the stroke of midnight on New Year's Eve people will kiss, honk car horns, bang pots and pans; blow whistles and make sounds with other noisemakers. The song "Auld Lang Syne" is played at the stroke of midnight to ring out the old and bring in the new. Some eat a soul food of black-eyed peas and rice called Hoppin' John. Cake and champagne are also consumed for "good luck". On New Year's Day, the popular sport of American football is televised all day long and special parties called Football Parties are thrown. Popular foods of the day are: beer, soda, large sandwiches up to 5 feet long called submarine sandwiches, potato chips, potato salad, pizza, pretzels, nuts, and candy. Those who do not watch football usually go shopping. Stores refer to the wives of men who watch the sports programming as Football Widows to dramatize the popularity of the sport. Happy New Year!

President's Day is the combined celebrations of the birthdays of George Washington and Abraham Lincoln. The original version of the holiday was in commemoration of George Washington's birthday in 1796 (the last full year of his presidency). In 1796, many Americans celebrated his birthday on the 22nd of February, and by the early 19th century, Washington's Birthday had taken firm root in the American experience as a bona fide national holiday. Then along came Abraham Lincoln, another revered president and fellow February baby (born on the 12th of the month). The first formal observance of his birthday took place in 1865, the year after his assassination, when both houses of Congress gathered for a memorial address. While Lincoln's Birthday did not become a federal holiday like George Washington's, it did become a legal holiday in several states. Apparently, while the holiday in February is still officially known as Washington's Birthday (at least according to the Office of Personnel Management), it has become popularly (and, perhaps in some cases at the state level, legally) known as "President's Day". This has made the third Monday in February a day for honoring George Washington and Abraham Lincoln, as well as all the other men who have served as president. (Yes, it is true. All of our presidents have been men, so far.)

Memorial Day is on the last Monday of May. On this day Americans honour the memories of their dead relatives. This day is also the beginning of summer. Americans go to relax at the beach or go to the mountains.

St. Patrick's Day honors Saint Patrick. It is also a celebration of Irish culture. In many cities there are St. Patrick's Day parades. In New York City, it is celebrated with a parade down Fifth Avenue, with people drinking "coll" beer and eating corned beef and cabbage, traditional Irish foods. Most people, Irish or not, wear coll on this day.

Today Americans play small tricks on friends and strangers alike on the first of April. One common trick on April Fools Day, or All Fool's Day, is pointing down to a friend's shoe and saying, "Your shoelace is untied." Teachers in the nineteenth century used to say to pupils, "Look! A flock of geese!" and point up. School children might tell a classmate that school has been canceled. Whatever

the trick, if the innocent victim falls for the joke the prankster yells, "April Fool". Most April Fools jokes are in good fun and not meant to harm anyone. The cleverest April Fools joke is the one where everyone laughs, especially the person upon whom the joke is played.

Independence Day is one of the most important holidays in America. It is celebrated on the 4th of July. On this day in 1776 the Declaration of Independence was signed in Philadelphia. There are picnics, parades and fireworks all over the country on Independence Day. Americans do not work: they have day-long picnics with their favourite food like hot-dogs, hamburgers, potato salad and others.

Halloween is a holiday celebrated mostly by children and the young. On the 31st of October they dress as vampires, witches and ghosts and go from house to house saying trick or treat. People should give them a treat otherwise, the children will play a trick on them.

Thanksgiving is one of the popular American holidays, too. It is celebrated on the fourth Thursday in November. This holiday dates back to the time when the first settlers, the Pilgrims, came to America. Their first winter was very hard, they had little food. In spring, the Indians taught them to plant and grow new crops, hunt and fish. The following autumn the colonists made a great feast for the Indians. At Thanksgiving American families gather and spend this day together. The traditional Thanksgiving food is roast turkey, pumpkin pies, cranberry jelly, ham, sweet potatoes, and other delicious food.

The United States is a young country, but it has a lot of great old and new holidays that are fun to celebrate. In the U.S., we refer to the months of November and December as "the holiday season" because of the major holidays celebrated from Thanksgiving to New Year's Day. The United States is a nation of many cultures that has adopted holiday customs from across the world, and we've developed a few of our own that stand out. Here's a handy guide to those traditions and customs of USA people.

Black Friday is one of them. You may have seen it on TV – the day after Thanksgiving in the U.S., crowds gather at stores across the country in the early hours of the morning in search of the best discounts on presents for the holidays. The event got its name from a phrase used in business – "in the black" – which means that a company has made a profit.

Father's Day commemorates and celebrates Dad. It is a day to not only honor your father, but all men who have acted as father figures in your life - whether as Stepfather, Uncle, Grandfather, or "Big Brother." Mrs. John B. Dodd, of Washington, first proposed the idea of a "father's day" in 1909. Mrs. Dodd wanted a special day to honor her father, William Smart. William Smart, a Civil War veteran, was widowed when his wife died in childbirth with their sixth child. The first Father's Day was observed on June 19, 1910 in Spokane, Washington. At about the same time in various towns and cities across America, other people were beginning to celebrate a "father's day." In 1924, President Calvin Coolidge

supported the idea of a national Father's Day. Finally in 1966, President Lyndon Johnson signed a presidential proclamation declaring the 3rd Sunday of June as Father's Day.

The U.S. is home to people from all over the world, and holiday celebrations are no different. Whether you are an international student spending the holiday season in the U.S. for the first time or the fifth time, these traditions are sure to get you into the spirit.

List of used literature:

1. <https://www.studyusa.com/en/a/1812/a-guide-to-holiday-traditions-in-the-u-s>
2. https://www.internationalstudentguidetotheusa.com/articles/holidays_customs.php
3. U.S. Diplomatic Mission to Germany /Public Affairs/ Information Resource Centers. Updated: December 2008

*Hamroyeva I.E.
EFL teacher
№42 secondary school
Uzbekistan, Bukhara, Jondor*

TEACHING STRATEGIES FOR YOUNG LEARNERS

Abstract :The article introduces teaching strategies for young learners how effective ways teach them .Today teaching strategies are important for all over the world teachers.

Keywords: Demonstration, Choral Drill, Look and Say, Pictorial Illustration, Verbal Illustration, Association, Questioning, Storytelling is effective for early foreign language classes strategies

Teaching English, especially for young learners (7–10 ages), should be enjoyable, interesting, repetitive and understandable. In doing so, there should be appropriate strategies for teaching English. Some strategies that can be applied in the classroom are the so-called, Songs, Pictorial illustration and TPR (Total Physical Response games, activities). These strategies try to introduce some language skills or components in an action. Using of them can be benefit to develop and improve listening and speaking skills that can be an option to learn grammar and vocabulary patterns easily. As it is known, at these ages children start to discover world broadly and their psychical and mental abilities are at the stage of developing. Around the world the term of young learners' age is differentiated. In most countries the primary school age is defined from 7 to 10. According to Piaget, children are active learners and thinkers. In addition, they are curious in learning as well as in discovering. Learning and teaching any language is challenging process and requires great patience. Young learners tend to have a lot of physical energy and more involved in visual learning, physical and social interaction. For the first time teaching young learners seems to be simple action but it demands more experience and knowledge that assist to make effective teaching. Making lessons more interesting for them is one of the most essential parts in teaching. Young learners will learn best if the people involved in the teaching process facilitate the learning and take into account the way young learners learn into the teaching practices. Piaget (1967 cited in Mc Closkey, 2002), suggested that children developed through specific stages, they are: Sensory-Motor Stage (from 0–2 years) in which children seems to learn through physical interaction with the world around them. Pre-operational stage (from 2–7 years) when children need concrete situations to process ideas. Concrete Operational Stage (from 7–11 years) in which children begin to conceptualize and do some abstract problem solving, though they still learn best by doing. Formal Operational Stage (from 11–15) in which children are able to use abstract

thinking. Another expert, Vygotsky (1978, cited in Hughes, 2009) believed that language was central to the cognitive development of children, that it was instruction provided by an adult that helped children learn and develop. Donaldson (1978, cited in Hughes, 2009) stated that children were able to cognitively develop by trying to make sense of the experiences that they had, and by asking questions and trying things out, or hypothesizing. Chomsky believed that learning was innate, in the sense that every child has an innate capability to learn a language. attention to sound and prosody (the ‘music’ of an utterance), whereas older children (12–14 years) are more attentive to cues of word order. Furthermore, Moon (2000:3) pointed out that young learner learns foreign language: – Through being motivated. It depends on the teacher’s style. I the teacher motivated them they would learn fast or quicker. – By listening and repeating. – By imitating the teacher. They want to please the teacher. They feel embarrassed when they make mistakes. – By doing and interacting with each other in an atmosphere of trust and acceptance, – Through a variety of interesting and fun activities for which they see the purpose. – Through translating sentences into their own language. Other teaching strategies for primary level of students by Bonnie Piller and Mary Jo Skillings California State University, San Bernardino USA: Demonstration, Choral Drill, Look and Say, Pictorial Illustration, Verbal Illustration, Association, Questioning, Narration, Read and Say.

Strategy 1: Demonstration – Demonstration includes the use of real objects, performing actions, using gestures, and facial expressions. It is used for presenting words like toy, bracelet, or hat. Demonstration can be used for sentence patterns that stand for concrete ideas. For example, saying «I am looking at my watch», or «I am cleaning the chalkboard» while performing these actions. The teaching strategy includes the teacher doing the demonstration and students practicing with feedback from the teacher. Demonstration is important. Demonstration builds connections between new knowledge and what the child already knows.

Strategy 2: Choral Drill – In Choral Drill the children all chant together following along as the teacher leads. It is the repeating of poems, nursery rhymes, the alphabet, an alphabet song, sentence patterns, and vocabulary lists. Children repeat the melody and rhythm. Choral Drill presented speaking aloud and verbatim memorization. This occurred in unison or in the form of echo recitation. The purpose was for transfer to the long-term memory. Current brain research supports the idea of speaking aloud 1Speaking generates more electrical energy in the brain than just thinking about something (Bower, 2003; Perry, 2004). Choral drill is also a powerful way to cause over-learning to occur. Over-learning, that is, continuing to recite after something is memorized, creates deeper memory traces that make for longer retention (Banich, 1997; Ridley Smith, 2004). This poem was heard: School is over, Oh, what fun! Lessons finished, Play begun. Who'll run fastest, You or I? Who'll laugh loudest? Let us try. (Children laughed loudly)

Strategy 3: Look and Say – Look and Say is the technique of students listening to the teacher and looking at the object or print, then repeating a word or sentence after the teacher. Children either watch as the teacher points to the words on the chalkboard or individually point to the print on a page or in a textbook.

Strategy 4: Pictorial Illustration – Pictorial illustration is the use of blackboard drawings, diagrams, sketches, match-stick figures, photographs, maps, and textbook illustrations. These are used for presenting words and structures that stand for concrete ideas. **Strategy 5:** Verbal Illustration – Teachers at each level used Verbal Illustration. Sometimes this was simply giving a phrase or sentence that showed the typical use of the word in context, as in «the sky is blue». **Strategy 6:** Association – Association was used for presenting vocabulary items. Teachers used Association for synonyms, antonyms, and simple definitions. For example, blossom -- flower (synonym) diligent -- hardworking (synonym) fresh -- stale (antonym) lad — means a boy (definition)

Strategy 7: Questioning – Questioning is another strategy that is used in lessons at all levels. It is used in the introduction. The questioning section of the lessons appeared to be for the purpose of developing thinking processes for concept formation. The Questioning strategy resembles the strategies described in the classic work of Hilda Taba (1967), in which she postulates that thinking can be taught. In Taba's inductive thinking model, questioning is used for concept formation, interpretation of data, and application of principle.

Storytelling is effective for early foreign language classes Storytelling can be effective for teaching English to young learners for the following reasons given by Wajnryb (1986): – The purpose of telling a story is genuinely communicative. – Storytelling is linguistically honest. (It is oral language, meant to be heard.) – Storytelling is real!(People do it all the time!) – Storytelling appeals to the affective domain. – Storytelling caters to the individual while forging a community in the classroom. – Storytelling provides listening experiences with reduced anxiety. In addition, conducting lessons with physical activities gives considerably high results in developing language skills comprehensively. Playing games has a significant role in the second language acquisition process. With the help of games children can also learn social skills: sharing, working as a team and helping each other. Playing games in the classroom develops the ability to cooperate, to compete without being aggressive, and to be a good loser. There will be expected that with the help of games and physical response teacher is able to create environmentally friendly atmosphere in language learning and to get students' attention. Also Schneider and Crombie (2003) announced a motto of multi-sensory techniques that is 'Hear it, see it, say it, write it, act it out' and make learning as active as possible. It is not refutable repeating the most effective factor in getting success in learning procedure. In general, children learn better when they are actively involved in lessons. However, in the view of diverse learning styles and preferences children display different results. For this reason properly

designed lessons may become efficacious in solving problems related to teaching process.

References:

1. Piaget, J. (1970). *Science of Education and the Psychology of the Child*. New York: Orion Press.
2. McCloske, Mary Lou. 2002. *Seven Instructional Principles for Teaching Young Learners of English*. Symposium, San Diego. http://home.comcast.net/~educatlanta/Handouts05/McCloskey_TESOL_Symposium02.pdf accessed on 29 September 2009
3. Annie Hughes and Nicole Taylor, *Research Seminar Papers* (2011). *Teaching English To Young Learners: Seventh International TEYL*
4. Hughes, Annie. 2009. *An Introduction to Teaching English to Young Learners*. http://www.ed2go.com/elt_demo/3te_demo/L02.htm, accessed September 10, 2009.
5. Slatterly, M., & Willis, J. (2001). *English for primary teachers*. Oxford: Oxford University Press. Ибрагимова, Ш. Р. *Teaching strategies for young learners (7–10 ages)* / Ш. Р. Ибрагимова. — Молодой ученый. — 2017.

*Irgashev M.U.
Senior teacher of department of foreign languages
faculty of agro engineering and hydro melioration
Andijan Institute of Agriculture and Agro technologies
Uzbekistan, Andijan*

SPECIFICITY OF VOCATIONAL TRAINING OF STUDENTS WITH DISABILITIES IN A HIGHER EDUCATIONAL INSTITUTION

Abstract: The article reveals the subject of specifics of disabled students' vocational training on the principles of their full integration into educational space and a justification of the ways of their overcoming in pedagogical, psychological, organizational and managerial aspects.

Keywords: inclusive education, students with disabilities, specifics of disabled students training.

Problems arising in the process of vocational training of a student with disabilities can be conditionally divided into two groups: the first will include problems related to the content and effectiveness of the student with disabilities, the second - difficulties associated with the student's personality traits that affect the results his training. It is these two aspects that constitute, in our opinion, the psychological and pedagogical specificity of vocational education of students with disabilities and work with them in the university [1, 2, 4].

In the personal aspect of the problems of vocational training of students with disabilities, the following personality characteristics are distinguished: difficulties in establishing interpersonal contact with fellow students, teachers, signs of a passive and often egocentric position; low level of independence; immaturity of the sense-motivational sphere; dependence on loved ones; overestimation of external indicators of general academic performance to the detriment of the quality of orientation in the mastered professional field. The listed characteristics, firstly, reduce the quality and effectiveness of educational activities of a student with disabilities, do not allow to fully engage in the subject space of professional activity; secondly, they make it difficult for a young person to enter the student body, to establish full-fledged professional and interpersonal relations. Taken together, these conditions form a psychologically uncomfortable situation of professional and personal development of a disabled student, which affects the success of his education and physical condition.

At Agrarian institute, the organization of the educational process is carried out on the principles of full integration of students with disabilities in order to obtain higher education in accordance with the specialty and the state educational standard on an equal basis with all students.

Purpose of the article: to identify the specifics, difficulties and barriers to vocational training of students with disabilities. To achieve this goal, the Academy conducted questionnaires and interviews of teachers and students with disabilities, integrated into the environment of communication with healthy students.

A questionnaire survey of the academy employees was carried out in order to study the awareness of teachers and staff about the typological characteristics of students with disabilities, the peculiarities of their education, as well as to identify common problems that exist in interaction with students with disabilities.¹⁰[1, 2, 4]

The objective of the research is to analyze the specifics of vocational training of students with disabilities and substantiate ways to overcome them in pedagogical, psychological, organizational and managerial aspects.¹¹[1, 2]

At the time of the study, 75 students with disabilities are studying at the agrarian institute, 84.4% with disabilities. The questionnaire survey allowed us to identify the problematic field associated with teaching disabled students. In 42 teachers and 75 students with disabilities took part in the questionnaire survey. In the course of the study, we analyzed the attitude of teachers to the fact that students with disabilities receive education at the Humanitarian and Pedagogical Academy. It was found that: positive attitude - 95% of respondents; are indifferent - 4%; take for granted - 1%. The overwhelming majority of teachers have a positive attitude towards teaching disabled people at the university, which should contribute to the successful adaptation of this category of students in the university environment.

The study of teachers' awareness of the presence of students with disabilities in their groups showed that: 85% of respondents know that disabled people are studying in their study groups; no - 10%; I don't know - 5%. These data indicate that teachers are sufficiently informed about the presence of disabled students in academic groups. At the same time, 40% of the respondents noted that they need additional information about the characteristics of students caused by disability; 50% noted that there is no such need; 12% - found it difficult to answer.

Of interest is the data on the sources from which teachers receive information about students with disabilities. The following sources of information on the presence of disabled students in academic groups are: personal observations - 70% of respondents; students with disabilities themselves inform - 8%; dean's office employees - 38%; Center employees inform - 50%. As experience shows, students with disabilities themselves rarely tell teachers about the presence of a disability, which does not always have a beneficial effect on their learning process. This conclusion is confirmed by the data of the

¹⁰ Abdullayeva N.S. Improving motivation of students when learning a foreign language in non-language higher education institutions. International scientific journal. Economy and society. № 6(73): 2020.

¹¹ Ahmadjonova Sh.N. The use of neuro linguistic programming in the process of learning foreign languages. International scientific journal. Economy and society. № 6(73) -s.: 2020.

questionnaire survey: only 8% of students with disabilities inform the teacher about the presence of a disability and discuss the specifics of mastering the content of a particular academic discipline. A significant part of the respondents notes that they receive information about the presence of disabled students in the academic group through personal observations - 65% of respondents. We believe that the possibility of assuming the presence of disability using personal observations is valid only for students with severe visual and musculoskeletal impairments. In other cases, documentary evidence of a disability is required.

A positive attitude towards students with disabilities contributes to their positive socialization in the university environment. Answers to the question: "What attitude do students with disabilities evoke?" were distributed as follows: sympathy, pity - 10%, positive attitude, respect - 40%, attitude to all students - 25%, undecided - 10%. Due to the fact that 60% of the respondents noted that in the process of work there are difficulties of various nature, we analyzed and systematized them.

Among the main difficulties, teachers identify the following: a low educational base of students with disabilities, an overestimation of their capabilities, results and quality of work, frequent complaints of difficulties, the requirement of indulgence in disability and the expectation of help, a high level of infantilism, the sensitivity of disabled students when establishing contact, the desire blaming others for your misfortunes. Thus, teachers associate the bulk of the difficulties arising in the process of teaching students with disabilities with the psychological characteristics of students.

According to the respondents: the state of health of students with disabilities is reflected in their educational activities - 85%; the quality of educational activity of disabled students does not depend on the state of health - 12%; I don't know - 3%. Teachers note that a significant part of the difficulties in educational activities are associated with the cause of the health disorder and the severity of the disease. This is especially true for students with visual impairment, musculoskeletal system, serious somatic diseases. The state of health of students with disabilities affects educational activities in terms of psychological problems, the ability to record lectures, perform written work and difficulties in the independent development of additional information on the discipline. Some teachers note another side of this process, namely, improperly organized educational activities can negatively affect the health of a student with disabilities.

References:

1. Abdullayeva N.S. Improving motivation of students when learning a foreign language in non-language higher education institutions. International scientific journal. Economy and society. № 6(73): 2020.
2. Ahmadjonova Sh.N. The use of neuro linguistic programming in the process of learning foreign languages. International scientific journal. Economy and society. № 6(73) -s.: 2020.

3. Brante T. Professional fields and truth regimes: In search of alternative approaches // *Comparative Sociology*. – 2010. – N. 9. – p. 843–886.
4. Evetts J. Organizational and occupational professionalism: The legacies of Weber and Durkheim for knowledge society // C. Marcuello, J. L. Fados (Eds.) *Sociological essays for a global society: cultural change, social problems and knowledge society*. Zaragoza: Prenas Universitarias de Zaragoza. – 2006. – p. 61–79.
5. N.A. Odilova. M.U. Irgashev. Information and communication technology in language learning. International conference., 2016, p.439.
6. Камынина Т. П., Моисеева Е. В. Information culture as the basis of professional activity competence of the future specialist / / III international scientific and practical conference - restoration. Ufa: BSPU Publishing house, 2011.

THE IMPACT OF THE GEOGRAPHICAL LOCATION OF THE REPUBLIC OF UZBEKISTAN ON THE FORMATION OF TRANSPORT CORRIDORS

Annotation. The article reveals the geographical position of transport in Uzbekistan, the emergence, formation and some aspects of the directions of development of transport corridors of the republic.

Keywords: Geographical location, Central Asia, transit, corridor, export, import.

Land transport is well developed in accordance with the geographical location of Uzbekistan. The development of transport is primarily based on its geographical location, relief and location of productive forces. In particular, the crossing of the ancient trade route was an important factor in the formation of the transport network of the republic. It should be noted that the location and development of the Republic's transport is greatly influenced by its unique geographical location in the center of Central Asia. It is surrounded by Kazakhstan to the north and west, Kyrgyzstan and Tajikistan to the east, and Turkmenistan to the south. There is no access to direct waterways.

It is known that the geographical location, topography and geological structure of the region play an important role in the formation of the transport network. From this point of view, the transport network and types of Uzbekistan are very different from neighboring republics.

The surface structure of Uzbekistan stretches from west to east, from west to east to 1430 km, and from north to south to 925 km. Samarkand, Navoi and the Republic of Karakalpakstan are bordered on South Kazakhstan, Kyzyl-Orda and Mangistau regions of Kazakhstan, and in the south Bukhara, Kashkadarya and Surkhandarya, Khorezm regions are bordered on Dashovuz and Lebap regions of Turkmenistan. To the east, it is bordered on Osh, Jalal-Abad and Batken regions of Kyrgyzstan. The regions of the Fergana Valley are bordered Jalal-Abad region of the Kyrgyz Republic to the north and northeast, to the northwest Sughd region of the Republic of Tajikistan, and to the southeast Batken region of Kyrgyzstan.

One of the important features of the borders of the regions is that the borders between the neighboring republics pass through the plains. The roads that connect them therefore intersect through economically well-developed areas from ancient times. In general, the economic-geographical and geopolitical position of the republic has an impact on the formation and appearance of its transport system.

Currently, the foreign trade of the Republic of Uzbekistan is carried out through the following main transport corridors:

Corridor 1 – in the direction of the ports of the Baltic States (transit through Kazakhstan and Russia) – Klaipeda (Lithuania), Riga, Liepaja, Ventspils (Latvia), Tallinn (Estonia);

Corridor 2 – in the direction of the European Union (EU), via Belarus and Ukraine (transit through Kazakhstan and Russia) – Chop (Ukraine) and Brest (Belarus) border;

Corridor 3 – to the port of Ilichevsk in the Ukraine (via transit from Kazakhstan and Russia), with access to the Black Sea;

Corridor 4 – in the direction of the Transcaucasian corridor, known as the TRACECA corridor (via transit from Turkmenistan, Kazakhstan and Azerbaijan), with access to the Black Sea;

Corridor 5 – to the Iranian port of Bandar Abbas (via transit from Turkmenistan), with access to the Persian Gulf;

Corridor 6 – in an eastern direction through the Kazakhstan-China border (Dostiq / Alalshankou) till the eastern ports of China, as well as till the ports of Nakhodka, Vladivostok and others in the Far East;

Corridor 7 - to Chinese ports (via transit from Kyrgyzstan) with access to the Yellow, East China and South China Seas;

Corridor 8 – due to the settlement of order to the Afghan problem a transit from Afghanistan opens up new prospects for the development of alternative southern transport corridors to the Iranian and Pakistani ports of Bandar Abbas, Chahbahar (Islamic Republic of Iran, IRI), Gwadar and Karachi (Islamic Republic of Pakistan, IRP).

The revival of the Great Silk Road was in 1995-2000, and a new route was added to it. In particular, on December 13, 1991 in Ashgabat, the leaders of Uzbekistan, Kazakhstan, Kyrgyzstan, Tajikistan and Turkmenistan agreed to jointly build the Tajan-Serakhs railway. The construction began in 1992 and in 1997 the construction of the 295 km long Tajan-Serakhs-Mashhad road was completed. The 130 km section of the railway is in the territory of Turkmenistan and 165 km in the territory of Iran.

Through these railways, Central Asian countries can access the ports of China on the Pacific coast and the Persian Gulf countries, and Europe through the Mediterranean.

The Tashkent-Farob-Tajan-Serakhs-Mashhad-Bandar Abbas (4122 km long) corridor is especially important for Uzbekistan. It is estimated that 5.3 million tons of cargo will be transported annually in this direction. The construction of this road from the Chinese ports on the Yellow Sea to Istanbul will significantly reduce the distance. If the Trans-Siberian Railway was 14,000 km at this distance, it is now 9,500 km in the Central Asian region. This road not only reduces the cost of transported goods, but also ensures its timely delivery.

Construction of the Tajan-Serakhs-Mashhad railway began in 1992 and was completed in 1996.

As the Trans-Asian Highway connects East Asia with Europe via the Central Asian transport system, European countries are also taking a keen interest in this direction. One of the alternative routes is the Uzbekistan-Kazakhstan-China route and it runs from Tashkent - Almaty - Taldykorgan - Druzhba - Alashankou - Urumqi to the Chinese ports of Lianyungang, Qingdao and Shanghai.

According to available data, freight traffic using new alternative corridors has been reduced from 5,700 km to 3,700 km from nearby ports in Uzbekistan, and 50% of exported cargo is transported through these roads (Kamolov S. T., 2001, p. 65-68). In addition, the climate of the region allows it to be used year-round. We spend more than \$100 per ton to transport Uzbek cotton to Ukrainian ports via Kazakhstan and Russia, while the cost is \$55 when transported via TRACECA (Arziev F., 1998).

The launch of new routes also means that the great legacy of Uzbekistan to world culture - the Great Silk Road - is being rapidly restored. One of them is the TRACECA (Transport Corridor Europe Caucasus Asia) project, which is part of the TACIS (Technical Assistance to the Commonwealth of Independent States) program, that is the Europe-Caucasus-Asia transport corridor. The implementation of this project directly applies to Uzbekistan.

Transport corridors should be economically safe in the first place. To this end, the countries concerned are interested in the directions that do not pose a threat to security.

In short, we can point to the following routes that allow Uzbekistan to access the sea:

- to the port of Karachi (Indian Ocean) through Afghanistan and Pakistan;
- Turkmenistan and Iran to the Mediterranean Sea through Turkey;
- to the ports in the Far East through the territory of Kazakhstan and China¹²;
- the Transcaucasian corridor, which leads to the Black Sea and the Mediterranean Sea via Turkmenistan-Caucasus. This corridor also allows access to European countries using the Danube River;
 - to Pacific ports through Kazakhstan-Russia;
 - to the seas of the Arctic Ocean, Europe through Kazakhstan-Russia; to the Baltic countries using Latvian ports;
 - to China and its seaports through Kyrgyzstan.

The revival of the Great Silk Road has been dubbed the “transport artery” of the new Europe-Caucasus-Asia. The above highways and railways further

¹² Under the third option, experts recommend the following route: Tajikistan-Kyrgyzstan-China is a railway in the southeast direction, Yangiabad-Ergashtom-Kashgar-Urumqi route is the closest distance connecting Central Asian countries to China.

enhance the global importance of highways of international importance. As part of them, roads in our country are developing in a unique way.

References:

1. Arziev F. The Great Silk Road Development Path // "Vatanparvar" newspaper, September 12, 1998, num. 109 (1061).
2. Kamolov S. Development of transport systems of Uzbekistan and the birth of the great rural route // Ministry of Foreign Economic Relations of the Republic of Uzbekistan. Information bulletin by num.1. –T., 2001. p. 65-68.
3. Schlichter. S. B. Transport factor of regional integration // New factors of regional development. –M., 1999. p. 56-63.

Ishankulov Sh.U.
teacher of the department of Foreign Languages
KEEI
Kashkadarya region, the city of Karshi
Niyozova Yu.T.
teacher of the department of Foreign Languages
KEEI
Kashkadarya region, the city of Karshi

TEACHING LISTENING COMPREHENSION

Annotation: This article outlines reasons for getting students to listen in English, the kind of listening that teachers use in classrooms, factors that make listening difficult, types of classroom listening materials, examples of listening material, dealing with listening problems.

Key Phrases: Listening performance; listening materials; redundancy; listening to tapes; spontaneous speech; script dictation; listening problems;

Ишонкулов Ш.У.
ҚМИИ, Хорижий тилар кафедраси ўқитувчиси
Қашқадарё вилояти, Қарши шаҳар
Ниёзова Ю.Т.
ҚМИИ, Хорижий тилар кафедраси ўқитувчиси
Қашқадарё вилояти, Қарши шаҳар

ТИНГЛАБ ТУШУНИШНИ ЎҚИТИШ

Аннотация: Ушбу мақолада талабалар инглиз тилида тинглашлари керак бўлган сабаблар, ўқитувчилар дарсларда фойдаланадиган тинглашнинг тур-лари, тинглашни қийинлаштирадиган омиллар, тинглаш материалларининг турлари, тинглаш материалларига мисоллар, тинглаш муаммоларини ечиш ҳақида маълумотлар берилган.

Таянч иборалар: Тинглашни бажариши; тинглаш материаллари; кўп маъноли-лик; тасмаларни тинглаш; беихтиёр; ёзув диктанти; тинглаш муаммолари;

Reasons for getting students to listen in English. One of the main reasons for getting students to listen to spoken English is to let them hear different varieties and accents – rather than just the voice of their teacher. In today’s world, they need to be exposed not only to one variety of English (British English, for example) but also to varieties such as American English, Australian English,

Caribbean English, etc. Despite the desirability of exposing students to many varieties of English, however, common sense is called for. The number of different varieties will be a matter for the teacher to judge, based on the students' level, where the classes are taking place etc. But even if they only hear occasional (and very mild) varieties of English, which are different from the teacher's, it will give them a better idea of the world language, which English has become. The main method of exposing students to spoken English (after the teacher) is with using by taped material, which can exemplify a wide range of topics. The second major reason for teaching listening is that it helps students to acquire language subconsciously even if teachers do not draw attention to its special features. Exposure to language is a fundamental requirement for anyone wanting to learn it. Listening to appropriate tapes provide such exposure and students get vital information not only about grammar and vocabulary but also about pronunciation, rhythm, intonation, pitch and stress. Lastly, just as with reading, students get better at listening the more they do it! Listening is a skill and any help we can give students in performing that skill will help them to be better listeners.

The kind of listening that teachers use in classrooms. The debate about the use of authentic listening material is just as fierce in listening as it is in reading. If, for example, we play a tape of a political speech to complete beginners, they will not understand a word. You could argue that such a tape would give them a feel for the sound of the language, but beyond that, it is difficult to see what they would get out of it. If, on the other hand, we give them a realistic (though not authentic) tape of a telephone conversation, they may learn much more about the language – and start to gain confidence as a result. Listening demands listener's engagement, too. Long tapes on subjects which students are not interested in at all will not only be de-motivating, but students might well 'switch off' – and once they do that it becomes difficult for them to tune back to the tape. Comprehension is lost and the listening becomes valueless. Everything depends on level, and the kind of tasks that go with a tape. There may well be some authentic material, which is usable by beginners such as pre-recorded announcements, telephone messages etc. Advanced students may benefit from scripted material if it is interesting and subtle enough – and provided the tasks that go with it are appropriate for their level. Since listening to tapes is a way of bringing different kinds of speaking into the classroom, we would want to play different kinds of tape to them, e.g. announcements, conversations, telephone exchanges, lectures, 'plays', news broadcasts, interviews, radio programs, stories read aloud etc.

Factors that make listening difficult. As teachers are preparing lessons and techniques that are exclusively for teaching listening, a number of special characteristics of spoken language need to be taken into consideration. Students need to pay special attention to these characteristics or factors because they influence the understanding of speech and can even make listening comprehension very difficult. These factors are the following.

1. Clustering - In written language we are conditioned to attend to the sentence as the basic unit of organization. In spoken language, we break down speech into smaller groups of words. In teaching listening comprehension, therefore, you need to help students to pick out manageable clusters of words; or they will err in the other direction in trying to attend to every word in an utterance.

2. Redundancy - Spoken language, unlike most written language, has a good deal of redundancy. The next time you are in a conversation, notice the repetitions, rephrasing, repetitions, elaborations, and little insertions of “I mean” and “you know” here and there. Such redundancy helps the hearer to process meaning by offering more time and extra information. Learners can train themselves to profit from such redundancy by first becoming aware that not every new sentence or phrase will necessarily contain new information and by looking for the signals of redundancy.

3. Reduced forms - While spoken language does indeed contain a good deal of redundancy, it also has many reduced forms. Reduction can be phonological, morphological, syntactic, and pragmatic. These reductions pose significant difficulties especially to classroom learners who may have initially been exposed to the full forms of the English language.

4. Performance variables (hesitation, topic change) - In spoken language, except for planned discourse, hesitations, false starts, pauses, and corrections are common. Native listeners are used from very young ages to such performance variables while they can easily interfere with comprehension in foreign language learners. Everyday casual speech by native speakers also commonly contains ungrammatical forms. Some of these forms are simple performance slips.

5. Colloquial language - Learners who have been exposed to standard written English and/or “textbook” language sometimes find it surprising and difficult to deal with colloquial language. Idioms, slang, reduced forms, shared cultural knowledge are all manifested at some point in conversations. Colloquialisms appear in both monologues and dialogues.

6. Rate of delivery - Virtually every language learner initially thinks that native speakers speak too fast! Actually, the number and length of pauses used by a speaker is more crucial to comprehension than sheer speed. Learners will nevertheless eventually need to be able to comprehend language delivered at varying rates of speed and, at times, delivered with few pauses. Unlike reading, where a person can stop and go back to reread something, in listening the hearer may not always have an opportunity to stop the speaker. Instead, the stream of speech will continue to flow!

7. Stress, rhythm, and intonation - The prosodic features of the English language are very important for comprehension. In addition, intonation patterns are very significant not just for interpreting such elements as questions and statements and emphasis but more subtle messages like sarcasm, insult, solicitation, praise, etc.

8. Interaction - Classroom techniques that include listening components must include instruction in the two-way nature of listening. Students need to understand that good listeners (in conversation) are good responders.

Types of classroom listening materials:

1. Reactive Sometimes you simply want a learner to listen to the surface structure of an utterance for repeating it back to you. While this kind of listening performance requires little meaningful processing, it nevertheless may be legitimate, even though a minor, aspect of an interactive, communicative classroom. This role of a listener as merely a “tape-recorder” must be very limited. The one role that reactive listening can play in an interactive classroom is in brief choral or individual drills that focus on pronunciation.

2. Intensive Techniques whose only purpose is to focus on components (words, phonemes, intonation, discourse markers) of discourse may be considered to be intensive – as opposed to extensive – in their requirement that students single out certain elements of spoken language. Examples of intensive listening performance include:

- ❖ Students listen for cues in certain choral or individual drills.
- ❖ The teacher repeats a word or sentence several times to “imprint” it in the students’ mind.
- ❖ The teacher asks students to listen to a sentence or a longer stretch of discourse and to notice a specified element, e.g., intonation, a grammatical structure.

3. Responsive - A significant proportion of classroom listening activity consists of short stretches of teacher language designed to elicit immediate responses. The students’ task in such listening is to process the teacher talk immediately and to give an appropriate reply. Examples include:

- Asking questions (“How are you today?” “What did you do last night?”).
- Giving commands (“Take out a sheet of paper and a pencil.”).
- Seeking clarification (“What was that word you said?”).
- Checking comprehension (“So, how many people were in the park?”).

4. Selective - In longer stretches of discourse such as monologues, the task of the student is not to process everything that was said but rather to scan the material selectively for certain information. The purpose of such performance is not to look for global or general meanings, necessarily, but to be able to find important information. Selective listening differs from intensive listening in that the discourse is in relatively long lengths. Examples of such discourse include:

- Speeches.
- Media broadcasts.
- Stories and anecdotes.

Techniques promoting selective listening skills could ask students to listen for:

- People's names.
- Dates.
- Certain facts of events.
- Location, situation, context, etc.
- Main ideas and/or conclusion.

5. Extensive - This sort of performance, unlike the intensive processing described above, aims to develop global understanding of spoken language. Extensive act could range from listening to lengthy lectures to listening to a conversation and deriving a comprehensive message or purpose. Extensive listening may require the student to use other interactive skills for full comprehension.

6. Interactive - Finally, there is listening performance that can include all five of the above types as learners actively participate in discussions, debates, conversations, role-plays, and other pair and group work. Their listening performance must be integrated with speaking.

Examples of listening material. The teaching of listening skills will follow the methodological model in the same way as for the teaching of reading skills. But training students in listening skills presents problems for both teacher and student which are not found with reading material. Listening as a skill certainly shares many similarities with reading. But the differences are there, too. Most importantly, the text itself is different. A written text is static. It can be consumed at the speed of the reader, and be read repeatedly. Not so spoken text: if it is on audio or video tape, it can be repeated, but it still happens at its speed, not the listener's. Of course, in conversation a listener can ask the speaker to repeat what is being said. However, the same is not true of a lecture you are listening to. Spoken language differs markedly from written text too. We have already discussed factors that make listening difficult. You should bear in mind that such speech phenomenon as hesitation reformulation, redundancy, pauses, reduced forms, and topic change and a natural part of spontaneous speech.

Listening for details and writing a Script Dictation. One way of having students listen to a tape in a detailed way is to give them a script dictation. This means that students are given the tapescript with some of the words blanked out. All they have to do is fill in the words. It is easy to create script dictations. Let us imagine that students have already listened to the text about National Gallery and answered the questions. The teacher now asks the students to try to fill in the gaps before listening to the tape again. They can be extremely useful in reminding students of the difference between written prose and the way people speak. Tapes, which the teacher makes, are often the most exciting ones for the teacher and the students to use. A warning needs to be given, however. In the first place, it is difficult to get good quality on some tapes and tape machines.

Dealing with listening problems. As we have already said, listening can cause problems. In general, these can be summarized as panic and difficulty. Students often panic when they see the tape recorder because they know that they

are faced with challenging task. Two things are guaranteed to increase that panic! The first is to refuse to play a tape more than once and the second is to expose an individual student's lack of success in the listening. It is usually a good idea to play a tape all the way through on a first listening so that students can get an idea of what it sounds like. If students have listened to a tape to answer a comprehension task it can be very threatening for the teacher to point to individuals and ask them for their answers to questions – especially when they know that they don't know! Some teachers and students find that listening to tapes is extremely difficult, especially when tapes are long. Yet we may want to use long extracts because they contribute to our overall teaching plan and because the topic is interesting. If the tape is difficult, there are a number of things you can do to make it easier.

- Give students the first third of the tapescript. They can read it at home if they want. In class, they discuss how the story is going to end or what is going to happen.

- Preview vocabulary. Choose a small number of key words that students do not know. Teach them to the students before they listen.

- Use the tapescript. In general, it may be a good idea for the students to look at the tapescript after the first couple of times listening if they are having difficulty in coping with the tape. You could also cut the tapescript into paragraphs – or even smaller pieces – which they have to put in the right order as they listen to the tape.

These are just some ideas to make your listening activities more motivating and more successful, especially where there are difficulties.

Real education must consider the whole child and the purpose of human life and civilization. Real education must acknowledge the spiritual and emotional development of the child; the importance and influence of the arts and real happiness on the education process; and integrate them into the curriculum and evaluation process.

In summary, after completing this article, you should be able to name eight factors that make listening difficult, name and describe six types of classroom listening materials, give examples of listening materials, explain how teachers can deal with listening problems in the classroom, and design your own listening exercises.

Additional Literatures:

1. Никитенко З. Н. Обучение произношению детей 6 лет в курсе английского языка для I класса // Иностранные языки в школе. – 1992. – № 1. – С. 36-43.
2. Павлова С. В. Обучение иноязычному произношению на коммуникативной основе. // Иностранные языки в школе. – 1990. – № 1. – С. 29-32.
3. Пассов Е. И. Методическое мастерство учителя иностранного языка // Иностранные языки в школе. – 1984. – № 6. – С. 24-29.

4. Douglas B. H. Teaching by principles: an interactive approach to language pedagogy – Longman, 2000. – 480 p.
5. Harmer J. How to Teach English [new ed.] – Pearson Longman, 2007. – 288 p.
6. Ishonqulov Sh. U., Ziyatov A.T. Emotional Intelligence and Spiritual Development: Modern Science International scientific journal № 11, Vol. II, 2020. pp. 224-226

*Ishonkulov Sh.U.
An English teacher of the
“Foreign languages” department
Karshi Engineering Economic Institute
Tursuniyozov D.O.
An English teacher of the
“Foreign languages” department
Karshi Engineering Economic Institute*

TEACHING SPECIFIC ASPECTS OF LANGUAGE

Annotation: In this article, it is outlined different methods of teaching English. It is also informed that every teacher should use interesting and productive methods of teaching English. They will help to improve students' knowledge. English lessons will be interesting for every learner. Our future generation must be intelligent and harmounslly developed.

Keywords: The deductive approach, the inductive approach, the inductive approach, explaining meaning, teaching grammar;

When we ask students to concentrate on specific aspects of language, we will usually choose some way of explaining the form and meaning of that language before asking for student repetition as part of a controlled practice phase of the lesson sequence. This explanation, repetition and practice is a form of what we have called study. Sometimes we will spend a lot of time on this language focus, and students will be involved in quite a few minutes of repetition. At other times, once our students' attention has been drawn to the language in question, they may well be able to move quickly to a stage of personalization or even full activation. In such cases, the study element has been brief because it has met with almost instant success. How long we have to spend on language study will depend on who the students are, what their level is and what elements of language we are asking them to study.

The deductive approach In a deductive approach, students are given explanations or grammar rules, for example, and then, based on these explanations or rules, they make phrases and sentences using the new language. In the following example, elementary students are going to focus on the present continuous tense. The teacher starts by showing them pictures of people doing certain actions (painting a house, fixing the roof, cutting the grass, etc). He or she then models a sentence about one of the pictures ('He's painting the house') before using a series of devices to draw the students' attention to the grammar of the present continuous. The students then repeat the second sentence. The teacher now cues the students with a prompt ('paint') and the students have to say 'He's painting the house', or 'fix' and they say 'He's fixing the roof'. They then use

what they are learning to make sentences about the other pictures, and as they do so, the teacher corrects where necessary. It can be seen that this explain and practice approach to teaching aspects of the language system looks very much like a straight arrows sequence in which the order of elements is engage —► study —► activate. It suits some students and language points very well.

The inductive approach In a so-called inductive approach, things happen the other way round. In other words, instead of going from the rules to the examples, students see examples of language and try to work out the rules. Thus, for example, after students have read a text, we might ask them to find examples of different past tenses and say how and why they are used. This boomerang-type lesson (where the elements occur in the sequence engage —► activate ->• study) is especially appropriate where language study arises out of skills work on reading and listening texts. If we want students to understand how speakers in informal conversation use certain phrases as delaying tactics (or to buy ‘thinking’ time) we might after letting them listen and respond to someone speaking spontaneously get them to listen again, but this time reading a transcript of what is being said.

That is what we would do explain and practice sequence. However, in an inductive approach we prefer the students to find this information out. If we are teaching ‘body language’, therefore, instead of telling students which verbs like ‘wave’, ‘clench’, ‘wag’, etc collocate with which nouns such as ‘hand’, ‘arm’, ‘teeth’, ‘fist’, etc, we can send them to monolingual learners’ dictionaries or computer corpuses to see if they can work it out for themselves. Such discovery activities ask students to do the work rather than having everything handed to them on a plate by the teacher or a grammar/ vocabulary book. Discovery activities suit some students very well; they enjoy working things out. It is generally easier for more advanced students to analyze language using discovery procedures than it is for complete beginners. The boomerang sequence is often more appropriate with students who already have. Teaching the language system a certain amount of language available to them for the first activation stage than it is with students who can say very little.

Explaining meaning One of the clearest ways of explaining the meaning of something is to show it. If we hold up a book, point to it and say ‘book ... book’, its meaning will be instantly clear. For actions, we can use mime: if we are teaching ‘He is running’, we can mime someone running. At other times, we can use gesture. We can demonstrate superlative adjectives, by using hand and arm movements to show ‘big ... bigger ... biggest’, and many teachers have standard gestures to explain such things as the past, or the future. We can also use facial expressions to explain the meaning of sad, happy, frightened, etc. We can use pictures to explain situations and concepts (for example, a picture of someone coming away from a swimming pool with dripping wet hair to show ‘She has just been swimming’). We can use diagrams too. Many teachers use time lines to explain time, simple versus continuous and aspect. For example, if we want to explain the present perfect continuous tense, we can use a timeline to demonstrate

'I've been living here since 2004'. If we can't show something in one of the ways mentioned above, we can describe the meaning of the word. For example, a 'generous' person is someone who shares their time and their money/possessions with you. 'Nasty' is the opposite of 'nice'. A 'radish' is a kind of vegetable. If describing meaning is not appropriate, we can list vocabulary items to explain concepts. For example, if we want students to understand the idea of the 'caring professions', we can list a number of jobs such as 'doctor', 'nurse', 'social worker' and 'counselor' to explain the phrase. We can also use check questions to make sure students have understood correctly. If they are learning how to make third conditional sentences and one of the examples is 'If she'd missed the bus, she would have been late for work', we can ask the students questions such as 'Did she miss the bus?' and 'Was she late for work?'. A way of making meaning absolutely clear, of course, is to translate words and phrases. Sometimes this is easy; all languages have a word for 'book'. Sometimes, however, it is more complex; many languages do not have an absolute equivalent for the English phrase 'devil may care attitude' and translating idioms such as 'to pull the wool over someone's eyes' means having to find an LI equivalent, even though it may be constructed completely differently. The trick of explaining meaning effectively is to choose the best method to fit the meaning that needs to be explained. In fact, most teachers use a mixture of some or all of these techniques. However, check questions are especially important since they allow us to determine if our explanations have been effective.

Teaching grammar One way of teaching grammar is to use an explain and practice procedure such as we have described above. So, for example, if we want to teach the present simple for habitual actions, we can show elementary students pictures of someone with an interesting occupation (in this case a marathon runner). After talking about running ('Would you like to run?', 'Do you take exercise?', etc), the students see the following pictures. We point to the first picture and model the sentence 'She gets up at half past five'. Now we draw the two hands together and say 'gets,.. gets ... listen, she gets . . . '). Then we model the sentence again and get the students to repeat it chorally and individually. Students now look at the second picture and we try to elicit the sentence (that is get them to produce it, rather than give it to them) 'She has breakfast at six o'clock'. If necessary, we model this sentence too, isolating 'has'. Students repeat this second sentence chorally and individually. We now start a cue-response drill where we say 'half past five' and the students say 'She gets up' or 'six o'clock', for them to say 'She has breakfast'.

Real education must consider the whole child and the purpose of human life and civilization. Real education must acknowledge the spiritual and emotional development of the child; the importance and influence of the arts and real happiness on the education process; and integrate them into the curriculum and evaluation process. An integrated education of this nature will enable the students

to connect through shared emotional experiences and to reach their full potential as the images of their higher selves, the divine.

In summary, there are different methods of teaching English. Every teacher should use interesting and productive methods of teaching English. They will help to improve students' knowledge. English lessons will be interesting for every learner. Our future generation must be intelligent and harmounslы developed.

References:

1. Caffo, A., De Caro, M. F., Picucci, L., Notarnicola, A., Settanni, A., Livrea, P., Lanciona G. E., & Bosco, A. (2012). Reorientation deficits are associated with amnesic mild cognitive impairment. *Am J Alzheimers Dis Other Demen*, 27(5),
2. Jeremy Harmer. "How to teach English" Pearson Education Limited 2007
3. Пассов Е. И. Коммуникативный метод обучения иноязычному говорению Е. И. Пассов. – М. : Просвещение, 1991. – 223 с.
4. Scrivener J. Learning teaching / J. Scrivener. – Macmilian Heinemann, 2002. – 218 p.
5. Ishonqulov Sh. U., Ziyatov A.T. Emotional Intelligence and Spiritual Development: Modern Science International scientific journal № 11, Vol. II, 2020. pp. 224-226

*Izzatillayev A.A.
master of the Department of Uzbek Linguistics
Faculty of Foreign Philology
National University of Uzbekistan
Correspondent of Tribuna.uz*

THE IMPORTANCE OF SPEECH ACTS IN ADVERTISEMENT CONCERNING TOURISM

Annotation: The article discusses the role of advertising in the development of tourism and the importance of speech acts in them. Advertising tourism is compared and offers are given in foreign and Uzbek .

Keywords: tourism, advertisement, advertising texts, speech act, directive, assertive, commissive

At the beginning of the 21st century, research in Uzbek linguistics based on the anthropocentric paradigm began to appear. These works are mainly reflected in the fields of sociolinguistics, cognitive linguistics, pragmalinguistics, psycholinguistics. M.Kh. Hakimov's doctoral dissertation on pragmalinguistics "Pragmatic interpretation of the text in the Uzbek language" for the first time spoke about the theory of speech act. The study of the text and the perceptual factor requires a different approach to the object of study, in particular, semantic, psychological, pragmatic, cognitive and linguocultural. Accordingly, the need for the study of advertising texts in linguistics is growing. After all, the XXI century - the century of science and technology - is difficult to imagine without advertising.

Speech acts are given special attention in the advertising texts of travel firms or agencies in foreign countries. A speech act is an address made by a speaker to a listener for a specific purpose in a specific environment. Speech acts affect the listener or the reader. There are classifications of speech acts by J. Austin, J. Sylr and other scholars. In particular, Sierle classified speech acts as follows:

1. Assertives (assertions) — to convince of something;
2. Directives (desires) — motivation for something;
3. Commissions (promises) _ making promises and striving to keep them;
4. Expressive (verbal etiquette) — verbal actions that have the meaning of behaving in a team and expressing their attitude to someone's behavior;
5. Declarations — are verbal acts about changing situations in reality.

Assertives, directives and commissions from above play an important role in advertising texts. Advertising texts are the main source of attraction for the listener (reader), that is the tourist. For example, below we will focus on the acts in it through some advertisements.

1. "Your story starts here. Meet the day with red rocks. " Sedona, Arizona, is famous for its white rocks. These rocks appear red at sunrise. Directive and assertive acts were used to encourage tourists to visit the city and enliven the beautiful scenery in front of them.

2. "Change your world outlook and thinking in the Virgin Islands." Millions of tourists have been attracted by writing this advertising text under the most beautiful picture of the Virgin Islands. If it weren't for the text and only the picture itself, the number of tourists would probably be less than expected.

3. "When it comes time to travel, age can't be a barrier." The purpose of the advertisement is to attract the attention of elders through the directive, to invite them to travel. And with this text, of course, the desired result can be achieved. Advertising like this can have a profound effect on elderly persons, who demonstrate aging as a cause of everything.

Are there any promotional texts in Uzbekistan that are attractive in the field of tourism? Unfortunately, no. Even most travel agencies or travel agencies have no notion how important advertising texts are. You can hardly see texts which attract traveller's attention in advertisements regarding to tourism. For example, if you look at advertisements for trips to Samarkand or Khiva, you will see a picture of one of the historical monuments with the text "Travel to Samarkand", "Travel to Khiva". Or the price of the tour will be recorded. Of course, the price is important. But tourists don't just decide based on whether the price is cheap or expensive. Not everyone travels out of pocket. First of all, the tourist should see an advertisement about the destination and be motivated.

Uzbekistan is second to no other country in terms of historical and architectural monuments. Most tourists are not aware of this. The reason is that we have enough problems and shortcomings in the text of advertisements and headlines. In order to increase the number of tourists in the XXI century, to develop tourism, there is a lack of pictures in Samarkand or Bukhara. Most of the visitors to our country are from the CIS countries. This means that our ads do not reach the whole world, or even when they do, they do not attract. We need to pay attention to the text of the advertisement, to look at it as a lucrative business too.

For example, how to advertise our famous cities? Here are some examples.

1. Samarkand. "If you don't believe in our power, look at the buildings we have built." If this text advertises a picture of the most beautiful monuments in the city, it can increase the number of tourists. The directive in the text can be justified.

2. Bukhara. "Tall buildings. For those who are looking for wonder." The monuments in Bukhara may not be beautiful as compared with the monuments in Samarkand, but they are high. In the text above, the advertisement also turns into an effective promotion from a dry image by directive.

3. Khiva. "Get out of your house and visit our palaces. The fortresses of Khiva are open to you. " In this text, too, the motivating speech act serves some sort of effectiveness.

In short, development is not possible if each sector goes its own way. The integration of sciences, fields is very important. If we take a linguopragmatic approach to tourism, it will bring great benefits to the country, both materially and spiritually. Significant advertisement will turn into one of the main ways to develop the tourism.

References:

1. Azimova I.A. "Psycholinguistic study of the semantic perception of newspaper texts in Uzbek language". Doctor of philosophy philology, - T .: National University of Uzbekistan, 2008.
2. Hakimov M.X. "Pragmatic interpretation of the text in Uzbek language", Doctor of philosophy philology - Tashkent: FA TAI of the Republic of Uzbekistan, 2001. - 283 p.
3. Safarov Sh.S. Pragmalinguistics / Sh.S.Safarov - T .: "National Encyclopedia of Uzbekistan", 2008.
4. Serl J.R. "Classification of illocutionary acts". J.R. Serl // "News in foreign linguistics": Vol. 17. The theory of speech acts. - M.: Progress, 1986 .-- S. 182.

*Sulaymanov S., Doctor of Technical Sciences
professor of the Department of Technosphere Safety
Tashkent State Transport University
Kamilov Kh.M.
basic doctoral student (PhD)
Tashkent State Transport University
Uzbekistan, Tashkent*

**RESULTS OF INTEGRAL SCORE ASSESSMENT OF TRAIN
DISPATCHERS BY SERIOUS AND STRENGTH OF WORKING
CONDITIONS (ON THE EXAMPLE OF THE SINGLE DISPATCH
CENTER OF UZBEKISTAN RAILWAYS JOINT STOCK COMPANY)**

Annotation: The article describes the values, parameters, levels of hazardous and harmful factors of production in the Single Dispatch Center, taking into account the rooms where train dispatchers operate, the technical means they use (radio, PC, VDT, etc.) and the type and volume of work performed. Based on the results of the certification of working conditions in the workplace, using tools and methods of control and measuring equipment that provide sufficient reliability for detection, the results of the integrated score assessment of the working conditions of dispatchers by indicators of severity and stress. On the basis of the map of working conditions of the workplace, the category of severity of working conditions of train dispatchers,

Keywords: train dispatchers, working conditions, labor, weight, strain, fatigue, ability to work, certification, classes, integral points, assessment.

The role of railway transport in solving the problems of rapid development and optimal placement of the country's production capacity, bringing the economy to a new level of quality is invaluable. It should be noted that the solution of these problems lays a solid foundation for the steady rapid growth of the country's GDP and the well-being of the population [1].

Uzbekistan's railways are the most important transport artery in the country's economy. Today, the increase in the flow of passengers and freight, both inside and outside the country (neighboring and foreign countries), is further increasing the demand for rail transport. Efficient use of the railway system, ensuring the uninterrupted flow of passengers and freight leads to a sharp increase in the responsibility of train dispatchers of the Single Dispatch Center of JSC "Uzbekistan Railways" to make clear and alternative decisions in standard and non-standard situations and ensure their implementation [2,3]. The sharp increase in the responsibility of dispatchers and the huge flow of information that must be analyzed in decision-making are leading to a significant increase in the severity and stress of their working conditions [4,5,6]. Therefore, the development and

implementation of organizational, technical, economic and sanitary-hygienic solutions to study the working conditions of train dispatchers and ensure their full compliance with sanitary and hygienic requirements, to ensure the safe movement of passenger and freight trains on schedule and is of practical importance.

During the certification of working conditions of train dispatchers, hygienic assessment of harmful and harmful hazardous production factors included in the working conditions maps of the workplace was measured using equipment, hygienic assessment of working conditions was carried out, recording the complex effects of hazardous and harmful factors. The results of the measurement and study of the harmful factors of the production environment and the labor process are included in the table of general assessment of working conditions in the workplace in terms of the degree of harmfulness and risk [7]. Then, a comparison of the established norms of harmful factors was made for the following workplaces: by relatively high harmful classes and levels; The total value of working conditions belongs to class 3.2, 3. The combined effect of 3 or more harmful factors in class 1; At values of 2 and more harmful factors belonging to classes 3.2, 3.3, 3.4, working conditions were assessed, respectively, by one degree higher class [8].

An analysis of the results of hygienic assessments of train dispatchers at the Single Dispatch Center based on the results of workplace attestation [8] showed that their working conditions are classified as 2.0 in terms of actual concentrations of harmful substances in the workplace, noise, infrared, ultrasound, vibration and radiation levels. 3.1 class, microclimate indicators in the cold period of the year, lighting environment of production rooms, 2.0 class on atmospheric pressure, 3.2 class on the severity of the work process, 3.3 on the effect of work process stress. belongs to the class [9].

The working conditions in the workplaces where train dispatchers work, according to the results of the general hygienic assessment, correspond to class 3.3 [9].

The complex effect of weight and stress on the working conditions of train dispatchers was assessed using the integrated scoring method. In this case, the scores were determined for the harmful and harmful factors of working conditions of classes 3.1, 3.2 and 3.3, taking into account the time of exposure of each factor. 2.4 points for exceeding the permissible level of noise in the workplace (RED), 5 points for performing work movements (with fingers) during the shift (stereotype), 5 points for the body in an awkward position (awkward posture) during the shift, the object 3 points for the duration of the observation period, 2.4 points for the size of the observation of the object, 3 points for the duration of continuous work during the shift, 6 points for the occurrence of nervous stress [10].

Based on the results obtained, the evaluation of the workload of train dispatchers based on integral points of labor and stress characteristics using the following formula

identified [10]:

$$T = x_{\max} + \sum_{i=1}^n x_i \times \frac{6-x_{\max}}{6 \times (n-1)} = 6 \text{ a, degree}$$

where x_{\max} is the maximum value of the factor points taken into account in the assessment, $x_{\max} = 6$ points; n is the total number of factors, $n = 7$; x_i is the score of the i -factor being taken into account, $i = 1, 2, 3, \dots, n$, which are the sum of the scores, $\sum_{i=1}^6 x_i = 26,8$ based.

Evaluation of the weight of labor activity by the value of integral points showed that the severity of the activity of train dispatchers is the sixth category [10].

The total sum of the harmful factor factors taken into account $\sum_{i=1}^6 x_i = 26,8$ based, train dispatchers can determine the percentage value of fatigue that occurs during a shift. In this case, it is advisable to use the empirical formula developed by researchers [10]:

$$y = \frac{\sum_{i=1}^n x_i - 15,6}{0,64} = 18\%$$

here: $\sum_{i=1}^6 x_i = 26,8$ - the total sum of the scores of the factors taken into account; 15.6 and 0.64 - regression coefficients;

According to the calculation, the fatigue of dispatchers during the shift is 18%. The percentage value of the work capacity of train dispatchers during the shift by the numerical value of the fatigue state was determined using the following formula:

$$R = 100 - U = 82\%,$$

where: $U = 18\%$ - fatigue state, in percent; 100% - the ability of the dispatcher to work in comfortable working conditions, in percent;

In conclusion, the integrated scoring method was used to determine the quantitative values of quality indicators of working conditions, in which the weight and strain of working conditions of train dispatchers is 6 degrees, fatigue is 18%, working capacity is 82%, working conditions of train dispatchers. It is advisable to pay an additional 12% overtime (compensation) [10].

References:

1. MM Ziyaeva. Ways to increase the role and efficiency of "Uzbekistan Railways" in the market of services // Scientific electronic journal "International Finance and Accounting" 2018 № 2.
2. Suyunbaev Sh.M. Effectiveness of the implementation of automated workplaces for train dispatchers // Proceedings of the international scientific-practical conference "Problems of increasing the efficiency of modern production and energy efficiency." - Andijon: AnMI, 2018. - 66-70 p.
3. S. Sulaymanov, XM Kamilov. Analysis of the results of video timing of the work of the train dispatcher (on the example of the train dispatcher of the single dispatch center of the joint-stock company "Uzbekistan Railways") // Vestnik TashIIT 2019 god №2, P. 215-220.

4. Rashidov V. A., Buronov IB Izuchenie tyajesti i napryajennosti trudovogo protsessa poezdnyx dispatcherov jeleznoy dorogi // Molodoy uchenyy 2016 god №8.6, S. 10-12;
5. Kuznetsov VG, Zakharov DV Approach to the assessment of the information load of the train dispatcher // Stroitelstvo, Materialovedenie, Mashinostroenie 2017 god №101, S. 135-140.
6. A.V. Vlasova. Coefficient of load UVD dispatcher as an indicator of the level of safety of polyotov // Scientific Bulletin of GosNII GA, № 22, 2018-S.103-108.
7. Regulations of the Republic of Uzbekistan "On the procedure for certification of workplaces on working conditions and the risk of injury to equipment" // Resolution of the Cabinet of Ministers of the Republic of Uzbekistan dated September 15, 2014 No 263, Tashkent, 2014;
8. The results of the certification of JSC "Uzbekistan Railways" on the working conditions and the risk of injury to equipment // Tashkent 2018;
9. S. Sulaymanov, XM Kamilov. Analiz rezultatov otsenke usloviya truda poezdnyx dispatcherov yedinogo dispatcherskogo sentra Aktsionernogo Obshchestvo «O`zbekiston temir yol`lari» // Безопасность жизнедеятельность глазами молодежи: сборник материалов В Всероссийской студенческой центральной. S. 204-206.
10. PN Solonshchikov, RM Gorbunov. Safety of labor on the working mestax. Uchebnoe posobie. Kirov. 2015g.-35-38 p.

PILGRIMAGE SITE "KHUZHAI SAROB ATA"

Annotation: In the developing world tourism is becoming the most valuable and invested sector. Improvement of shrines and sanctuaries, development of tourism, especially domestic tourism have become one of the most urgent tasks today. Understanding history will eventually help raise morale, strengthen culture and most importantly increase pride in the spirit of the nation.

Keywords: Pilgrimage tourism, Jizzakh region, Zaamin district, Khuzhai Sarob Ata, Mavlono Muhammad Peshagory and tourist facilities.

Uzbekistan has a great deal of historical places, so tourism in our country is developing day by day. One of such historical sanctuaries is located in Zaamin district of Jizzakh region. This historical shrine is named "Khuzhai Sarob Ata".

At the crossroads near the village of Pishagar, Zaamin district, there is one of the outstanding pilgrimage sites. The locals call this locality "Khuzhai Sarob Ata" (translated from Persian as "master of the source of water"). This place of worship is shrouded in greenery, trees and a poly garden, and at the time of guests' stay their souls will be filled with light and purity. Peace and the absence of adversity, as if they would recede from visitors to the places and time will stop and be filled with light and grandeur. A little higher you can watch the tomb of the saint and a mosque is spread out around Volizi which gives these places extraordinary grandeur and hospitality.

Of course, you ask whose coffin is in these places and the answer is very simple, the coffin is one of the most prominent thinkers of antiquity Mavlono Muhammad Peshagory. According to some sources, the thinker of antiquity was born in 1321. You can find information about the outstanding person in the annals of "Rashkhat-ul ainulkhayet" which belongs to Fakhriddin Ali ibn Voiz al Kosifiy. According to these data, the religious views of Mavlono Muhammad Peshagory was born in 700 according to the Christian calendar while many knew him under the names "Khozhai Ser-ob" or "Khozhai Sar-ob".

It is said that Mavlono Muhammad Peshagory arrived in these places from distant lands and remained to live on this earth until the end of his life. It is surprising that this person did not choose this locality for nothing, since the presence of mountain springs, beautiful nature good-natured people forced Mavlono Muhammad Peshagory to stay here and continue to carry the banner of thought among the local people. Among the local elders, legends are heard that Mavlono Muhammad Peshagory built a small house and began to work on this land, taking the name "Peshagory" that is "From Peshagor" which gave him the

opportunity to get closer to local customs and traditions.

Untill the last days of his life, Khuzhai Sarob Ata lived in a small settlement where he was engaged in gardening , growing grapes and was engaged in teaching young people craft and honest work.

Among the people they are famous for their charisma and have a beneficial effect on human health.If someone warms up water from a given stream , do not hesitate that the water flowing in these streams and springs will become life-giving moisture for those who suffer and will help cure clean mountain streams that are known to be an ailment.

Incredibly, the water flowing in the stream like a mirror of the soul, makes it possible to enjoy the incredible taste of pure water and cool the fervor of even the most hated inhabitants.Sacred fish swimming in the springs play in the water, enjoying the gifts of nature and bread crumbs provided by the pilgrims.

This is what testifies to the purity and fragrance of these places . With independence, the pilgrimage place Mavlono Muhammad Peshagory became the center of ecotourism, here you can meet guests both from neighboring region and from abroad.A huge contribution to the development of the infrastructure of the shrine was made by the residents of the village of Pishagor A.Ilashev, Y.Akhmedov and S.Karshiboev. With their help from 1997 to 2001, the shrine itself occupies more than 2 hectares of land.

Of course, independence has given us the opportunity to study our stories in more detail, to preserve the heritage of our fathers , to recognize and be proud of who our ancestors were and today when the people of our immense country believe in tomorrow, we with rich pride can declare the presence of a truly historical heritage of the Uzbek people.

We can see many such places in the area as they tell stories from ancient times.The improvement of housing conditions not only by the government but also by the people living in the area enables them to reach their full potential and offer cultural leisure, as everyone in the area believes that their lifestyle is inextricably linked with them

References:

1. www.zomin.uz
2. www.google.uz
3. www.zomin.jizzax.uz
4. O.Burgutli.Tashkent 1996.

*Khusainov O.Dj.
researcher
of Karshi Engineering Economic Institute (KarEEI)
Uzbekistan*

**SOCIO-ECONOMIC CHARACTERISTICS OF THE DEVELOPMENT
OF THE INFRASTRUCTURE SYSTEM PROVIDING SERVICES TO
THE LIVESTOCK NETWORK IN THE CONDITIONS OF
INNOVATIVE ECONOMY**

Annotation: the article describes the socio-economic features of the development of infrastructure serving the livestock sector in an innovative economy

Keywords: innovative economy, livestock farming, infrastructure, services, efficiency, socio-economic problems, innovative development

In the period after the refusal of administrative orders in the agrarian network of the Republic and the transition to the development of free market relations, the livestock sector has been developing mainly on the account of the private network, the state orders for the cultivation of livestock products have been abolished, in most cases the state has paid little attention to the development. The main attention was paid to the implementation of measures for the development of cotton and grain-growing agricultural enterprises, the development of service entities belonging to this sphere.

As a result, today 90-94% of livestock and livestock products grown in the country are transferred to farms. At the same time, there has been a decline in the establishment and development of livestock services. It was noted that the main service sectors in the field of production have been established and formed for cotton and grain farms.

In recent years, special attention has been paid to the development of infrastructure serving the livestock sector. In this regard, the Resolution of the President of the Republic of Uzbekistan dated January 29th, 2020 "On additional measures to support the livestock sector by the state" is the basis for addressing important issues. In this regard, there is a growing need to develop infrastructure that serves the livestock sector.

From the point of view of the goals of regional economic development, the livestock sector can increase the income of rural families through the strengthening of the food base, the system of service to the sector, the development of livestock processing, by easing the problem of employment in the region is necessary to create opportunities to solve both economic and social problems.

Global climate change, pasture degradation, population growth and increasing demand for food will make more efficient use of available resources, in particular, the systematic use of service infrastructure in the production of livestock products needs to be improved.

It is known that without the innovative development of service infrastructure, it is impossible to achieve positive results in the livestock sector. In this regard, it is necessary to improve the functioning of service infrastructure in the regions, including the provision of breeding and veterinary services, ration-based feeding, organization of product processing and similar activities. To solve these problems, it is important to ensure the innovative development of systemic service infrastructure in the livestock sector.

In the conditions of innovative economy, the process of developing the infrastructure system serving the livestock sector can give the expected result only if it is carried out directly in conjunction with the process of production development. At the same time, it is necessary to implement measures, which include the following issues:

- planning of the volume of livestock production, resource supply and sales of products and strategic directions of development of the industry should be carried out in parallel with the development of the services sector;
- The development of the production, transportation and processing and sale of livestock products should be accompanied by the improvement of the system of lending and financing of services;
- In establishing a system of various services to livestock farms, it is necessary to consider the issues of professional development, economic incentives for the system of income generation on farms;
- Improving the system of material and technical resources for the production, storage and processing of livestock products, encouraging the import of modern equipment and technologies should be applied simultaneously to the direct services sector;
- It is expedient to implement comprehensive programs, including the development of various services to the industry, along with measures to encourage the introduction of advanced agricultural technologies and the achievements of agricultural science in the field of production, processing, quality control of livestock products.

The development of infrastructure facilities serving the livestock sector and ensuring their effective operation should be carried out not only under the protection of the problems of business entities, but also under the protection of the state. This is because the enterprises of the system that serve the sector, such as the agricultural sector, are constantly in need of state support and protectionist policies.

At the same time, the state will have to take measures that meet the requirements of market relations and take into account the specifics of rural areas and the industry. Including:

- In the organization of infrastructure facilities serving the livestock sector, it is necessary to take into account the level of specialization of the regions, as well as the high efficiency of infrastructure facilities;

- Livestock network service infrastructure take into account the degree of specialization of territories, the establishment of infrastructure facilities need to provide for high efficiency;

- It is advisable to make extensive use of economic, financial and legal incentives to ensure the sustainability of existing service providers. In particular, preferential loans for the production infrastructure, the tax system and other similar economic and financial incentives should be introduced on a regular basis.

- Given that the deep specialization of production infrastructure serving the livestock sector will increase the quality of services and reduce prices, it is necessary to create a legal and organizational framework for the emergence of free and healthy competition in the services sector.

The development of service infrastructure sectors depends not only on the conditions created for them, but also on the conditions created for the development of farms. Therefore, it is necessary to take into account this feature in regulating the development of infrastructure entities serving the livestock sector.

Expanding the conditions for the development of infrastructure for the livestock sector, increasing the share of services in GDP (gross domestic product), increasing the number of people employed in the service sector, especially in rural areas, an important area of employment, personal assistants, farmers and livestock keepers and on this basis it should be noted that the income of the population will increase.

References:

1. Campbell, R. M., Stanley, L. B., Sean, M. F. (2012). Microeconomics: Principles, Problems and Policies. (pp.392-395). New York. The McGraw-Hill Companies, Inc.
2. Vakhobov, A.V., Khajibakiev, S.H., & Muminov, N.G. (2010). Foreign investment. Tutorial. Under the general editorship of Doctor of Law, Professor AV Vakhobov (Ed.). (p.256). Tashkent: Finance.
3. Kuznetsova, A.I. (2010). Infrastructure: Issues of theory, methodology and applied aspects of modern infrastructure arrangement. Geoeconomic approach. Ed. 2nd. (p.456). Moscow: KomKniga
4. Fayzieva Sh. Development of livestock farms and increase of their efficiency. Dissertation for the degree of Candidate of Economic Sciences. – T., 2001. – 157
5. Jennings P.G.A. “Livestock Production in Unfavorable Economic Environments” USA-2006.
6. Mallabaev T.S. Ekonomicheskie problem intensivatsii skotovodstva: dis. d-ra econ. science. - T., 1984. - 364 p

7. Rashidov J.X. Problems of service development in the context of deepening economic reforms in agriculture. Dissertation for the degree of Candidate of Economic Sciences - Т., 2004. - 158 p.;
8. Rahmatullaev A.I., Khusainov, O. Dj. (2020). Ways of innovative development of animal husbandry. ISJ Theoretical&AppliedScience, 02 (82), 445-450
9. Collection of statistical indicators of achievement national SDGS in the republic of Uzbekistan. Tashkent, 2019 y.
10. Sh.Sh.Fayzieva, N.M.Jalilova The role of innovation in the development of entrepreneurship in agriculture [Электронный ресурс]. Economics. № 1 (44). 2020 (Дата обращения: 06.12.2020 URL: <https://economic-theory.com/images/PDF/2020/44/Economics-1-44-A.pdf>)
11. Abdurakhmanov K.Kh., Mukhitdinov E.M., Shakarov Z.G., Nabiev O.A., Amanov O.A. Labor migration and its impact on employment of population // МНИЖ. 2019. №4-2 (82). URL: <https://cyberleninka.ru/article/n/labor-migration-and-its-impact-on-employment-of-population> (дата обращения: 19.12.2020).
12. Amanov O.A. THE IMPORTANCE OF DIGITAL TECHNOLOGIES IN ENSURING EMPLOYMENT [Электронный ресурс]// Экономика и социум.- 2020.- №12(79) (дата публикации: 14.12.2020).- URL: https://a78cf8ac-3ef5-4670-8fcd-a900ec94fdfb.filesusr.com/ugd/b06fdc_274dd51640744059aa540e946f304bdf.pdf?index=true (дата обращения: 16.12.2020)
13. Fayzieva Shirin Shodmonovna, Yuldasheva Shakhribonu. (2020). Ways to solve problems in attracting investments in the country's agrarian sector. International Journal of Advanced Science and Technology, 29(08), 163-3166. Retrieved from <http://sersc.org/journals/index.php/IJAST/article/view/25335>

*Kolesnikova Yu.S., candidate of economic Sciences
Institute of management Economics and Finance
Federal state Autonomous educational institution
of higher education "Kazan (Volga region) Federal University"
Russia, Kazan*

DIGITALIZATION OF INDUSTRY AS A VECTOR OF A NEW DIGITAL SPACE

Abstract: The article deals with the issues of digitalization of production, its main concept and goals. The author proves the effectiveness of digitalization on the example of successfully functioning enterprises. The results of the study can be used to develop the processes of digitalization of industries and strengthen their focus on the growth of competitive advantages and technological development of regional spatial and sectoral structures in the digital economy.

Keywords: innovation, competitiveness, industry, digital economy, digitalization.

In the modern economy, the digitalization of industry is evidenced by the use of new types of equipment, which include: robotic devices, waste-free and unpopulated technologies, flexible processing complexes, automatic production facilities, unmanned vehicles, automated technical and technological platforms at various stages of the production process, equipped with digital sensors, sensors, etc. Computer and information systems, digital and network technologies due to the high quality, speed and reliability of transmission, storage and processing of digital signals and other properties ensure the adoption of timely decisions aimed at increasing labor productivity, competitiveness, development of innovations and their implementation in production processes.

Digitalization of industry is the concept of a new digital space, a single system that integrates production machines, systems for ensuring the life and safety of the enterprise, that is, all the electronics of the organization. Sensors and sensors make it possible to combine various physical objects into a virtual network in which they can interact with each other without human intervention.

The most important advantage of digitalization is to increase the productivity of the enterprise by reducing the time required to develop a new product, release it to the market and deliver it to the consumer, as well as to optimize the resources of the company, which increases the efficiency of its work as a whole. The modern concept of digitalization of enterprises was first outlined back in 1996 in the book "Being Digital" by Nicholas Negroponte, who at that time headed the MIT Media Lab company. However, then it was only about theory, only now there is a technical opportunity to put into practice the ideas of a digital enterprise. In modern conditions, there is a real need for digitalization of

industrial enterprises, since the problem of processing huge amounts of data that occurs in large industries can only be solved by using machines. Modern technologies enable machines not only to perform automatic actions, but also to interact with each other in different areas of the enterprise. Summarizing the above, we can say that we are talking not only about the automation of individual stages of production, but also about the introduction of digital technologies in the end-to-end process, which includes not only production stages, but also related financial and organizational activities. The new approach provides mobility, increases the speed of decision-making and increases the variability of processes depending on the needs of the client. Digital transformation of the enterprise. As mentioned earlier, for the transition to a digital enterprise, it is necessary to conduct General digitalization and integration of production and other processes vertically, starting from product development and ending with production, logistics and in-service maintenance. However, there is also a need for horizontal integration, which goes far beyond one organization and covers both the firm itself and its partners, suppliers and customers.

Digital transformation using a variety of modern technologies should be based on an appropriate digital platform. A digital platform is understood as a set of digital data, models and tools that are information and technologically integrated into a single automated control system for the target subject area, in addition, this platform should organize the interaction of stakeholders among themselves. It is very important to emphasize that for the transition to a digital form of business, it is necessary to conduct a digital transformation of the enterprise, which implies the use of the entire pool of modern ICT technologies to radically increase the productivity and value of enterprises. Perhaps it is better to put it another way: a radical increase in the productivity, competitiveness and value of enterprises today is possible with the parallel digitization of business processes and their fundamental reengineering (BPR, Business Process Reengineering).

If earlier in production only optimization of its separate phases or stages was considered, today within digital transformation and creation of the digital enterprise the end-to-end process including not only purely production stages from idea, development, design, purchases before production, but also the accompanying financial activity, work of personnel, logistics, operation, support, partner network, subcontractors, etc. is analyzed. After all, the main goals of digital transformation are to increase the speed of decision-making, increase the variability of processes depending on the needs and characteristics of the client, reduce the number of employees involved in the process (that is, decision-making and value creation chains). In General, sociality, mobility, Analytics and "clouds" are the Foundation on which a digital enterprise is built. And it is quite logical that this results in a potentially higher level of labor productivity, collaboration, cooperation, control, support and, accordingly, predictability of the result of work. And the timing and cost of launching new products are sometimes reduced

significantly. All this is done in the name of radically increasing the profit, competitiveness and market value of the enterprise. And if you do not see what exactly can seriously increase the competitiveness of the enterprise, then the question of payback or targeted use of investments in digital transformation immediately arises. This issue will be especially important for monopolies. The digital enterprise provides for the digitalization and integration of vertical processes throughout the enterprise, from product development and procurement to production, logistics and in-service maintenance. In turn, the horizontal integration of the digital enterprise goes beyond internal operations and covers suppliers, consumers and all key partners throughout the value chain. It uses a variety of technologies, from tracking and monitoring devices to comprehensive planning integrated with real-time execution. All this is done on the basis of the corresponding digital platform and all together makes up the so-called digital ecosystem of a digital enterprise.

Summarizing all the above, a radical increase in the production volume and value of the enterprise, as well as its competitiveness in the market, is possible only if all business processes are digitally transformed. Digitalization of an industrial enterprise. Before digitalization of companies, it is necessary to conduct comprehensive research in advance, which will allow you to know in advance how modern concepts and technologies can affect their business. It is necessary to have accurate data on the capacity and capabilities, the General condition of the target enterprise, in order to correctly set the goals of digital transformation and achieve a positive result in the end.

To create a program for digitalization of industry, you must first answer the following questions:

I. what can digitalization give?

II. What are its goals for the enterprise?

III. At what stage of digital transformation is the organization currently at, which of the technologies used can be saved?

IV. What kind of digitalization work can the company perform on its own, and for which it will need the help of specialists?

Subsequently, the list of questions expands, there is a need to choose the appropriate tools, software and technical solutions. However, at the first stage, it is necessary to decide whether such a transformation can currently lead to positive results for the company and whether such a transition will be economically justified.

What does digitalization bring? The benefits of digital transformation are best seen in examples. One of the most successful projects implemented to date can be considered a project of Siemens, where not only develop, but also apply smart systems.

The Corporation has launched an electronics plant in Amberg, which specializes in the production of industrial controllers. The company produces more than 1,000 products with a volume of about 12,000,000 controllers annually.

More than 75% of all work performed is carried out by works and automated machines, production is integrated with the design subsystem-design systems transmit all the necessary data about technological processes directly to production. The codes printed on the models inform the equipment about the technological route and the requirements for each operation performed. This technology allows you to achieve a product quality indicator at the plant at the level of 99.999%.

Every day, more than 50 million records of a production and technical nature are created in production, which can be used to track the entire life cycle of manufactured products.

By implementing IOT in production, companies seek to convert the benefits of Industry 4.0 technologies into clear business indicators. For example, the manufacturer of machine tools, the Japanese Corporation FANUC, reduced equipment downtime and thereby received \$40 million more revenue for the year. In the production of Stanley and Black tools & Decker after the introduction of IoT, the number of defects and marking errors decreased by 16%. And Singapore-based electronics maker Flextronics has reduced power consumption at its plants by 20%.

If we talk about global cases, one of the most striking examples is the Chrysler plant in Toledo, which produces more than 700 car bodies every day. At the same time, 259 German KUKA robots are involved, which "communicate" with 60,000 other devices and machines. And all this data exchange and storage is organized in a cloud environment. As a result, the productivity and flexibility of such a plant is significantly increased, not to mention the efficiency of process management.

Our research has shown several reasons for Uzbekistan's lagging behind the leading countries in the field of digitalization:

1. economic Instability exacerbated by the effects of the pandemic. There are few manufacturers of high-quality hardware in the country: processors, sensors, modems, etc. , and foreign products are expensive and sometimes simply unavailable for the domestic market.

2. Lack of clear standards. For the effective development of the high-tech market, it is necessary to have standards in the field of IoT, which are only beginning to appear in domestic legislation. Individual processes are not at all structured at the state level, which greatly hinders the introduction of digital technologies.

3. Lack of qualified specialists

The country's educational system lags behind the development of the digital technology market and does not have time to provide interested companies with high-quality personnel.

4. The Desire of the business to make a quick profit

Many domestic companies are interested only in the most liquid projects, which in the short term will be able to bring a large income. In Western countries,

corporations are happy to invest billions of dollars in projects with a payback period of 30 years; in our country, companies try to invest only in technologies that will pay off in two years. Therefore, digitalization is generally less attractive for domestic businesses.

Unfortunately, many enterprises cannot yet realize the full potential of digitalization and the possibilities of switching to new technologies [6,7,10].

The digital transformation project is best complemented by the use of the "digital maturity model" as a basis for determining the current state and desired state, in terms of the main areas key to sustainable business.

Thus, the successful implementation of digitalization of industry will contribute not only to the transition to a digital economy, taking into account modern realities, but also to increase the position of Uzbekistan in the relevant world indices and ratings, as well as to strengthen the country's image in the international arena. It is important that our state takes its rightful place in the world economy thanks to technology and innovation.

References:

1. Abdullayev, A.M. and ets. (2020). Analysis of industrial enterprise management systems: essence, methodology and problems. *Journal of critical reviews JCR*. 7(14): 1254-1260. Doi: <https://dx.doi.org/10.17605/OSF.IO/E6JFS>
2. Abdullaev, A. M., & ets. (2019). Actual issues of activization of financial factors development of entrepreneurship in Uzbekistan. *Kazakhstan Science Journal*, 2(3), 49-58.
3. Ashurov, M.S., and ets. (2020). Entrepreneurship and directions of its development in the context of the COVID-19 pandemic: theory and practice. GlobeEdit Academic Publishing. Doi: <https://doi.org/10.5281/zenodo.4046090>
4. Ashurov, M. S. and ets. (2019). O'zbekistonda tadbirkorlik muhitining zamonaviy holati va uni samarali rivozhlantirish muammolarini baholash.. *GlobeEdit Academic Publishing*. Doi: <http://dx.doi.org/10.13140/RG.2.2.34273.74088>
5. Ashurov, M.S. (2018). Muvaffaqiyatli biznes juritish uchun tadbirkorlik muhitining zamonaviy holati va uni samarali nazorat qilish muammolarini baholash (O'zbekiston Respublikasi materiallari asosida) // *Jekonomika i finansy (Uzbekistan)*. 12. URL: <https://cyberleninka.ru/article/n/muvaffa-iyatli-biznes-yuritish-uchun-tadbirkorlik-mu-itining-zamonaviy-olati-va-uni-samarali-nazorat-ilish-muammolarini-ba-olash-zbekiston>
6. Bessière, D., Charnley, F., Tiwari, A., & Moreno, M. A. (2019). A vision of re-distributed manufacturing for the UK's consumer goods industry. *Production Planning & Control*, 30(7), 555-567.
7. Davlyatova, G.M., and ets. (2020). Marketing as the main factor in introducing innovative products to the market. *ACADEMICIA: An International Multidisciplinary Research Journal*. Volume: 10, Issue: 5. P.430-437. Doi: <https://dx.doi.org/10.5958/2249-7137.2020.00229.3>

8. Fitzgerald, M., Kruschwitz, N., Bonnet, D., & Welch, M. (2014). Embracing digital technology: A new strategic imperative. *MIT sloan management review*, 55(2), 1.
9. Frank, A. G., Mendes, G. H., Ayala, N. F., & Ghezzi, A. (2019). Servitization and Industry 4.0 convergence in the digital transformation of product firms: A business model innovation perspective. *Technological Forecasting and Social Change*, 141, 341-351.
10. Iyosov, A. A., and ets. (2020). Problems of the use of digital technologies in industry in the context of increasing the export potential of the country. *ISJ Theoretical & Applied Science*, 10 (90), 113-117.
11. Ivanov, D., Dolgui, A., & Sokolov, B. (2019). The impact of digital technology and Industry 4.0 on the ripple effect and supply chain risk analytics. *International Journal of Production Research*, 57(3), 829-846.
12. Ivanovich, K. K. (2020). About some questions of classification of institutional conditions determining the structure of doing business in Uzbekistan. *South Asian Journal of Marketing & Management Research*, 10(5), 17-28. Doi: <https://doi.org/10.5958/2249-877X.2020.00029.6>
13. Kurpayanidi, K. I. (2019). Theoretical basis of management of innovative activity of industrial corporation. *ISJ Theoretical & Applied Science*, 01 (69), 7-14. Doi: <https://dx.doi.org/10.15863/TAS.2019.01.69.3>
14. Kurpayanidi, K. I. (2020). Actual problems of implementation of investment industrial entrepreneurial potential. *ISJ Theoretical & Applied Science*, 01 (81), 301-307. Doi: <https://dx.doi.org/10.15863/TAS.2020.01.81.54>
15. Kurpayanidi, K. I. (2020). To issues of development of entrepreneurship in the regions: theory and practice of Uzbekistan (on the materials of Andizhan region). *ISJ Theoretical & Applied Science*, 06 (86), 1-10. Doi: <https://dx.doi.org/10.15863/TAS.2020.06.86.1>
16. Kurpayanidi, K.I. (2020). Some issues of macroeconomic analysis and forecasting of the economy of Uzbekistan. *Iqtisodiyot va innovatsion texnologiyalar. Ilmiy elektron jurnali*. 2, mart-aprel. p.100-108.
17. Kurpayanidi, K. I. (2020). To the problem of doing business in the conditions of the digital economy. *ISJ Theoretical & Applied Science*, 09 (89), 1-7. Doi: <https://dx.doi.org/10.15863/TAS.2020.09.89.1>
18. Kurpayanidi, K. I. (2020). On the problem of macroeconomic analysis and forecasting of the economy. *ISJ Theoretical & Applied Science*, 03 (83), 1-6. Doi: <https://dx.doi.org/10.15863/TAS.2020.03.83.1>
19. Kurpayanidi, K.I. (2018). Questions of classification of institutional conditions, determining the structure of business management in Uzbekistan. *ISJ Theoretical & Applied Science*, 09 (65): 1-8. Doi: <https://dx.doi.org/10.15863/TAS.2018.09.65.1>
20. Kurpayanidi, K.I. (2018). The typology of factors of increasing the innovative activity of enterprise entrepreneurs in the industry. *ISJ Theoretical & Applied Science*, 10 (66), 1-11.

21. Kurpayanidi, K.I., (2020). Corporate industry analysis of the effectiveness of entrepreneurship subjects in the conditions of innovative activity. *Journal of Economy and Business*. 2-1. P.164-166. Doi: <https://doi.org/10.24411/2411-0450-2020-10111>
22. Mamatova, Z. M., Nishonov, F.M. end ets. (2019). To the question of Science approach to the construction of outsourcing business model of modern enterprise structure. *Достижения науки и образования*. 7 (48).
23. Мамуров, Д. Э. (2019). К вопросу методов поддержки инновационной деятельности. *Экономика и бизнес: теория и практика*, (10-2). Doi: <https://doi.org/10.33619/2414-2948/48/29>
24. Margianti, E. S., Ikramov, M. A., Abdullaev, A. M., & Kurpayanidi, K. I. (2020). Role of goal orientation as a predictor of social capital: Practical suggestions for the development of team cohesiveness in SME's. Monograph. Gunadarma Pulisher, Indonesia. Doi: <http://dx.doi.org/10.13140/RG.2.2.28953.44641>
25. Motyl, B., Baronio, G., Uberti, S., Speranza, D., & Filippi, S. (2017). How will change the future engineers' skills in the Industry 4.0 framework? A questionnaire survey. *Procedia Manufacturing*, 11, 1501-1509.
26. Tkach, D. V. and ets. (2020). Some questions about the impact of the COVID-19 pandemic on the development of business entities. *ISJ Theoretical & Applied Science*, 11 (91), 1-4. Doi: <https://dx.doi.org/10.15863/TAS.2020.11.91.1>

*Kulliyev O.A.
teacher of the Department of Economics
Jiyanov L.N.
teacher of the Department of Economics
Bukhara State University*

INNOVATIVE DEVELOPMENT AND AGRICULTURAL APPROACH TO AGRICULTURE

Annotation: Agricultural organizations are developing facilities for processing agricultural raw materials.

Keywords: agro-industrial complexes, development, agricultural development, cluster, entrepreneur, raw materials, technologies, competition.

*Qulliyev O.A.
"Iqtisodiyot" kafedrası o'qıtuvchılari
Jiyanov L.N.
Buxoro Davlat universiteti
"Iqtisodiyot" kafedrası o'qıtuvchılari*

QISHLOQ XO`JALIGIDA INNOVATSION RIVOJLANISH VA KLASTERGA YONDASHUV

Annotasiya: Qishloq xo'jaligi tashkilotlari qishloq xo'jaligi xom ashyosini qayta ishlaydigan quvvatlarni rivojlantirish masalalarini hal qiladi.

Kalit so'zlar: agrosanoat majmualari, rivojlanish, qishloq xo'jaligini rivojlantirish, klaster, tadbirkor, xom ashyo, texnologiya, raqobat.

Mamlakatda olib borilayotgan iqtisodiy islohotlar O'zbekiston Respublikasining milliy iqtisodiyotini jahon iqtisodiyotiga munosib o'rin egallashga qaratilgan. Buning uchun ikkita asosiy shartga rioya qilish zarur: birinchidan, jahon iqtisodiy hamjamiyatida hukmronlik qiladigan tamoyillar va mexanizmlar islohotlar uchun asos bo'lishi kerak;

Ikkinchidan, islohotlarni amalga oshirishda avvalgi rivojlanish xususiyatlari va mamlakat iqtisodiyotining hozirgi holati, aholining milliy madaniyati va o'zini tutish xususiyatlari, transformatsiya davri davomiyligi va mamlakat taraqqiyotini shakllantiruvchi boshqa omillar va sharoitlar hisobga olinishi lozim. Ushbu tamoyillar hududlarda agrosanoat majmualarini (AIK) yangi boshqaruv tizimini yaratish orqali amalga oshirilishiriladi.

O'zbekiston Respublikasi mustaqil davlat sifatida O'zbekiston fuqarolarining farovonligi va erkinligini, mamlakatning iqtisodiy tiklanishini, innovatsion jamiyatni yaratish va mehnat unumdorligini o'sishi asosida ichki

iqtisodiyotning o'sishi va farovonligini ta'minlashi kerak bo'lgan islohotlarni amalga oshirishi juda muhim va asosiy vazifalardan biri.

Yangi boshqaruv paradigmasining qoidalari islohot qilinayotgan iqtisodiyot va butun jamiyatning ob'ektiv ehtiyojlarini aks ettirishi kerak. Buning asosiy, muhim jihatlarni yangi boshqaruv tizimini qurishda foydalanish. Bu esa mamlakatimizning rivojlanishning innovatsion barqaror yo'lga o'tishiga yordam beradi.

Dastlabki bosqichda klaster yaratishning eng qiyin lahzasi uning aktivlarini shakllantirish bo'yicha tadbirkorlar o'rtasida kelishuvga erishishdir.

1. Mintaqani rivojlantirishning uzoq muddatli strategiyasi
2. Mintaqani ijtimoiy-iqtisodiy rivojlantirishning uzoq muddatli dasturi
3. Mintaqani ijtimoiy-iqtisodiy rivojlantirishning o'rta muddatli dasturi
4. Mintaqalararo integratsiya tashabbuslari
5. Shaharlararo integratsiya tashabbuslari
6. Mintaqalararo hamkorlik tashabbuslari
7. Qishloq xo'jaligi mahsulotlarini ishlab chiqarish va klasterlarni tashkil etish bo'yicha mintaqalararo kooperatsiya va tashabbuslar

Klaster yaratishda iqtisodiy manfaatlarni birlashtiruvchi omillar quyidagilar bo'lishi mumkin:

- 1) tovar bozorida yagona narx siyosatini olib borish;
- 2) uning ishtirokchilari tomonidan tovar va xizmatlar ishlab chiqarish hajmini kengaytirish;
- 3) yagona marketing siyosatini olib borish;
- 4) innovatsion texnologiyalarni joriy etish - mahsulot ishlab chiqarish va ularni tovar bozorlarida sotish integratsiyasi va kooperatsiyasi natijasida.

Qanday bo'lmasin, mamlakat mintaqalarida qishloq xo'jaligi mahsulotlarini klasterlash hududlarning ixtisoslashuvini hisobga olish zarurati bilan bog'liq.

Qishloq xo'jaligi klasterlarini tashkil qilishda tashkilot madaniyati (korporativ madaniyat), boshqaruvni demokratlashtirishning turli shakllari, xodimlarning foydani taqsimlashda, mulkchilikda, boshqaruvda, etakchilik uslubi va etakchilikni tanlashda ishtirok etishi kabi omillarga e'tibor qaratish lozim.

Oziq-ovqat xavsizligini, mustaqilligini ta'minlashga intilayotgan har bir davlat milliy qishloq xo'jaligi holatiga befarq emas albatta. Mintaqaviy hukumat qishloq xo'jaligi ishlab chiqaruvchilari uchun etarli darajada daromad olish uchun zarur shart-sharoitlarni ta'minlashga, shuningdek samarali iqtisodiy va ijtimoiy siyosat orqali ularning rivojlanish barqarorligini ta'minlashga intilishi kerak.

Mamlakatdagi mavjud vaziyat o'rganib quyidagilarni tavsiya qilish mumkin:

1. Qishloq xo'jaligi tashkilotlari qishloq xo'jaligi xom ashyosini qayta ishlaydigan quvvatlarni rivojlantirish masalalarini hal qiladi. Bu qishloq aholisini oziq-ovqat bilan ta'minlashga yordam beradi. Qishloqning ijtimoiy infratuzilmasi rivojlanish uchun mablag'larni shakllantirishga qaratilgan mintaqaviy darajadagi iqtisodiy mexanizm kerak.

2. Qishloq xo'jaligi sohasini davlat tomonidan qo'llab-quvvatlashning asosiy elementlari quyidagilar bo'lishi kerak: qishloq tovar ishlab chiqaruvchilarini mavjud kredit resurslari bilan yanada ta'minlash, mahalliy tovar ishlab chiqaruvchilarga nisbatan keng imkoniyatlar yaratish:

3. Agrosanoat majmuasi tizimidagi faoliyatni klaster asosida to'g'ri kombinatsiyasi raqobatdosh ustunlikni va uning barqarorligini, shu jumladan axborot texnologiyalaridan foydalanish orqali ta'minlaydi. Shuni ta'kidlash kerakki, axborot inqilobi raqobatga quyidagi yo'llar bilan sezilarli ta'sir ko'rsatadi:

- soha tarkibini o'zgartiradi va raqobatning yangi qoidalarini belgilaydi;
- kompaniyalarga mahsuldorlik bo'yicha raqobatchilardan ustun bo'lish uchun yangi imkoniyatlar berish orqali raqobat ustunligini yaratadi;
- ko'pincha kompaniyadagi mavjud jarayonlar va operatsiyalar asosida butunlay yangi biznes turlarini yaratadi;
- biznes jarayonlaridagi o'zgarishlarning yo'nalishi va tartibini, xususan qishloq xo'jaligi klasterlarini tashkil etish orqali belgilaydi;
- xodimlarning malakasini doimiy ravishda oshirish zarurati uchun sharoit yaratadi.

Ijtimoiy-iqtisodiy tizim sifatida mintaqaviy strategik menejment uchun ijtimoiy, ekologik va iqtisodiy tarkibiy qismlarni hisobga olish kerak, ularning oxirgisi hal qiluvchi hisoblanadi.

Mintaqaviy strategik boshqaruv tizimini shakllantirishda ta'sirning tegishli darajasini aniqlash eng muhim ahamiyatga ega. Hokimiyat va boshqaruvning vakolatlari doirasida amalga oshiriladigan boshqarish ob'ekti bo'yicha iqtisodiyotning ishlashining umumiy shartlari, shuningdek, boshqariladigan ob'ektga ta'sir o'tkazish jarayonida ishtirok etadigan resurslar miqdori bilan belgilanadi.

Adabiyotlar:

1. Қишлоқ хўжалигида ихтисослашган кластерларни шакллантириш: тажрибалар, натижалар ва инновацион ёндашувлар. Республика илмий-амалий анжумани материаллари. 74-77 bet. 2020 йил 9 ноябрь.
2. Формирование кластеров в сельском хозяйстве региона.
3. Предпосылки создания кластеров в экономике региона (на примере Тамбовской области).
4. www.edu.uz.
5. www.ziyonet.uz.
6. www.agriculture.uz

UDK 004.02:004.5:004.9

DOI 10.46566/2225-1545_2020_1_79_151

Kurbonov A.B.

*Associate Professor of the Department of innovation economics
of the Karshi Engineering and Economic Institute*

Karshi

Jalilova N.M.

Senior Lecturer

Department of innovation economics

Karshi Engineering and Economic Institute

Karshi

Safarov K.B.

master

of the Karshi Engineering and Economic Institute

Uzbekistan, Karshi

DIRECTIONS FOR THE FORMATION OF COOPERATION IN THE FIELD OF AGRICULTURAL ENTREPRENEURSHIP

Abstract: The article analyzes the theoretical views of economists on the formation of the category of entrepreneurship. The features of the development of entrepreneurship in agriculture are also studied. The factors influencing the formation and development of agribusiness property are analyzed. In the context of the Republic of Uzbekistan, forms of ownership of agricultural enterprises are based. Scientifically grounded proposals and recommendations have been developed to increase the role of cooperation in the formation of property in agriculture.

Keywords: entrepreneurship, creativity, business, private-individual entrepreneurship, private-corporate entrepreneurship, partnership, agro-industrial complex, small business, cluster, cooperation, households.

One of the main tasks of economic reforms in countries is to improve the welfare of the population, and the material basis of economic growth is production, which ensures the effective organization of small business and private entrepreneurship. For this, it is necessary to improve organizational, economic and private relations, as well as to correctly solve existing problems. This requires a deep understanding of the socio-economic nature of entrepreneurship. The approach of modern economists to the problem of entrepreneurship has a special place. Based on their research, the analysis of the essence of entrepreneurship can be divided into the following areas: The first area - entrepreneurship - is an independent economic activity aimed at making a profit.

The second direction is the achievement of high production efficiency based on relationships in the implementation of new combinations of resources, without denying the goal of making a profit from entrepreneurial activity.

The third direction is that a creative approach is needed to manage the movement of resources of entrepreneurial activity. These include D. V. Busygin [2], V. D. Kamaev [3], I. N. Gerchikova [4], F. M. Rusinov [5] and others. In the studies of these scientists, entrepreneurship is reflected not as a simple labor activity, but as a creative activity. Thus, these authors have divided entrepreneurship into three integral, interrelated components.

Based on the above suggestions and recommendations, we can say that entrepreneurship is a production, service activity that includes the process of pooling and mobilizing resources, management based on innovation and risk for profit.

Entrepreneurship is an activity in which, in connection with the production of goods and services, the actual use of personal or other material and monetary resources, that is, capital, is carried out. Therefore, entrepreneurship is associated with the function of capital.

Small business and private entrepreneurship is an important component of a market economy. This is a mass basis and element of the market competition mechanism. The development of a market economy without entrepreneurship, including small business, is impossible even to act.

In our opinion, business and entrepreneurship are economic categories that represent economic relations between business entities. Business is a primitive economic category in relation to entrepreneurship and has a number of characteristics. These include: business participants seeking profit or utility; to this end, they seek to make efficient use of capital property and the function of capital; feel the economic risk, danger; they will be businessmen, masters of their craft, proactive, innovative, with a culture of economic relationships, skills; business participants will benefit from collaborative interaction.

Thus, business as an economic category is a set of relationships between people in the conduct of economic activities in order to make a profit. This set of relationships includes property, direct production, exchange, and customer relationships.

Since entrepreneurship is one of the key aspects of business, in our opinion, it represents a secondary productive relationship compared to business relationships. These relationships are associated with the production and service activities of people in order to make a profit.

Entrepreneurship, like other forms of business, requires the following conditions:

- economic independence and independence. An entrepreneur can use his full economic potential only if he is able to act freely;

- Striving for innovation, creativity, entrepreneurship. Only then will he become an entrepreneur when he improves his business, adapting to the changing

requirements of the market, can only if he has an idea of renewal, and also brings it to life;

- an inclination to take risks, a sense of property responsibility, etc.

Also, unlike business, entrepreneurship requires deep knowledge in the production of goods and services, professional skills.

Entrepreneurship is manifested in state, non-state, including private, mixed forms of ownership. Non-state forms include private-individual and private-corporate entrepreneurship. In turn, the subject of private entrepreneurship will be based on their own and hired labor. Private-corporate entrepreneurship is manifested as a partnership, mixed, leased enterprises.

Individual entrepreneurship includes private entrepreneurship, family businesses, self-employment based on their own labor, private and hired labor. The collective form of entrepreneurship includes state, agricultural cooperative enterprises, partnerships and self-governing firms, joint-stock companies, labor collective enterprises, etc.

Individual and collective forms of entrepreneurship are distinguished depending on the level of organization.

Individual entrepreneurship includes private entrepreneurship, family businesses, self-employed, self-employed, private and hired labor.

The collective form of entrepreneurship includes state, shirkat farms, corporations, partnerships and self-governing firms, labor collective enterprises, joint stock companies, etc. According to the field of activity, entrepreneurship has the forms of production, service provision, commercial activity and commercial intermediation. The form of entrepreneurship in the form of small, medium and large businesses, depending on the number of employees employed at the enterprise.

Depending on the level of business organization, its manifestation in one form or another depends on a number of factors. Organizational, organizational form of entrepreneurial activity, first of all, the entrepreneur's personal interest, the desire to declare oneself; secondly, the field of activity; third, the amount of cash; fourthly, it depends on the propensity to take risks [7].

Each form of entrepreneurship has its own advantages and disadvantages. For example, individual entrepreneurship is its simplest form; all organizational and managerial work is performed by one person. For example, individual entrepreneurship is its simplest form; all organizational and managerial work is performed by one person.

For example, individual entrepreneurship is its simplest form, all organizational and managerial work is performed by one person, that is, the simplicity of the organization. He assumes all responsibility and a strong economic incentive, that is, the receipt of all profits by one person. In this case, the entrepreneur conducts production and commercial activities only at his own discretion, that is, not associated with the need for coordination in decision-

making. But the entrepreneur assumes all the responsible risks associated with his business.

Consequently, the bankruptcy of the entrepreneur is determined, the risk of loss of property is high. This type of entrepreneurship is widespread in areas of economic activity that do not require large financial and material resources to start a business and are not technologically complex. Sole proprietors are people who are inclined to take risks and are able to take on all the dangers.

Partnership entrepreneurship is more common in areas that require slightly more financial and material resources and have a more complex technological base than sole proprietorship. This form of entrepreneurship is organized by a number of persons who jointly own and operate an enterprise. The main rights here belong to all partners. They exercise effective control over each other's activities.

One of the modern forms of entrepreneurship is the corporate form. It operates mainly in the form of a joint stock company. The share of each of its participants is determined by the number of shares belonging to him [8]. The most important advantage of this form of business is the very limited liability of shareholders, the separation of the function of capital, that is, the separation of capital from property, the ability to raise additional funds by issuing shares. Such societies mainly predominate in spheres of economic activity that require more financial and material resources, technologically large scale and a complex material and technical base.

In the process of working in a free market economy, small business changes the form and types of organization, and under the influence of its capabilities and the external environment, it can move from one form to another. In developed and developing countries, small business and private entrepreneurship perform several key functions. By creating new jobs, it balances the social costs of necessary structural changes in the economy. In the process of introducing the principles of a market economy in Uzbekistan, it is also necessary to develop small business and private entrepreneurship, and consistently study the experience of foreign countries in this direction.

In Uzbekistan, the economic policy pursued by the state aimed at building a democratic society, a fully functioning market economy based on the priority of private property, should include the development of small business and private entrepreneurship in today's economic development strategy.

As a result of economic reforms in the agro-industrial complex, economic entities were formed on the basis of various forms of ownership, and some objects of property were privatized and transformed into private-individual, private-corporate forms of entrepreneurship. In the field of agricultural production of the agro-industrial complex, first of all, corporate farms have been created, including farms, dekhkan farms. Cultural, household and trade facilities in the service sector were privatized and operated as private enterprises, production infrastructure facilities were transformed into joint stock companies MTZ,

MMTP, fertilizer supply, seed supply, fuel supply. Agricultural processing enterprises were transformed into joint stock companies due to their large production capacity and technology. In this area, only small enterprises for the processing of vegetables and fruits have been formed.

The interdependence of the activities of economic entities based on different forms of ownership in the field of the agro-industrial complex creates agrarian relations. Agrarian relations are relations between various entities involved in the production, processing, sale and production of agricultural products.

The activities of all economic entities in the agricultural sector lead to the formation of agribusiness, since agribusiness differs from the entrepreneurial movement in other sectors. Because on the basis of this industry is the production of agricultural products in connection with land relations. This means that in the agro-industrial complex there are features of the organization of private entrepreneurship.

Effective organization of the current and future activities of small enterprises and private entrepreneurs working in the agro-industrial sector, the ratio must be ensured. The efficiency of the current and future activities of small businesses and private entrepreneurs operating in the agro-industrial sector depends on the ratio of profit and cost.

In our opinion, due to the interdependence of the agro-industrial complex, it is advisable to establish cooperation that unites industries, and this cooperation is based on the material base of large farms and small processing enterprises towards infrastructure enterprises. This cooperation is organized on the basis of financial mergers of enterprises of the agro-industrial complex and is the basis for the development of agricultural producers and processing enterprises.

Members of the cooperative are small enterprises of the agro-industrial complex, united by functional areas of production. It is carried out by the executive body on the basis of the decision of the created council of the cooperative. For example, agriculture uses about 2500 agricultural machines, and not all of them can be purchased by one small enterprise. MSCI do not have the opportunity to purchase agricultural equipment.

The state also lacks the ability to supply sophisticated agricultural machinery to every region. Because the development of agriculture in itself does not provide stability in the country. Other industries also need development. It can be encouraged by the state only through organizational, legal, economic and financial incentives

In such a situation, it is possible to combine the capabilities of small businesses and become self-sufficient on a cooperative basis. The members of the joint cooperative in the field of technology and technology will voluntarily pool their financial resources for the purchase of agricultural machinery, the purchase of processing equipment, the purchase of the necessary equipment for infrastructure enterprises.

The use of equipment and technologies obtained from the accumulated financial resources is fully used by the property owners by decision of the council of the cooperative, the members of the cooperative are provided with benefits in their services. Small businesses that are not members of the cooperative are charged a full service fee. The profit from this is deducted from the costs of organizing and operating the cooperative and distributed among the owners in accordance with their contribution. It is advisable to apply this order of interaction in other functional combinations.

References:

1. Экономика и организация рыночного хозяйства в России М.: Прогресс, 1995. 155 стр.
2. Бусыгин А.В. Предпринимательства: Основной курс –М.: «ИНФРА-М» 1997.-608 стр.
3. Котлер Ф. Маркетинг менеджмент: Экспресс- курс.-СПб.: «Питер», 2007-496стр.
4. Герчикова.И.Н. Менеджмент.М.:ЮНИТИ,2007.418стр.
5. Русинов.Ф.М Возрождения предпринимательство в России. Майкоп:1999 27-28 стр.
6. Kurbonov A. B., Shoxo'jaeva Z. S. Sustainable development of the agrarian sector depends on the efficient use of water resources //International Journal of Engineering and Advanced Technology. – 2019. – Т. 8. – №. 6. – С. 5123-5126.
7. Курбанов Алишер Бобокулович. РОЛЬ МАЛОГО БИЗНЕСА В ИННОВАЦИОННОЙ ДЕЯТЕЛЬНОСТИ // Economics. 2020. №1 (44). URL: <https://cyberleninka.ru/article/n/rol-malogo-biznesa-v-innovatsionnoy-deyatelnosti> (дата обращения: 14.11.2020).
8. Amanov O.A. Ways of regulation, condition and employment trends of the population of the republic of Uzbekistan. Journal of Management Value & Ethics. India. ISSN: 2249-9512 Vol 8, №2, 2018.–P.98-106. URL: https://www.jmveindia.com/journal/APRIL-JUNE_18.pdf
9. Турсунов Имамназар Эгамбердиевич, Курбанов Алишер Бобокулович Инновационные подходы развития предпринимательства // International Journal of Innovative Technologies in Economy. 2018. №5 (17). URL: <https://cyberleninka.ru/article/n/innovatsionnye-podhody-razvitiya-predprinimatelstva> (дата обращения
10. Kh, Abdurakhmanov K., et al. "Labor migration and its impact on employment of population." Международный научно-исследовательский журнал 4-2 (82) (2017). URL: <https://research-journal.org/economical/labor-migration-and-its-impact-on-employment-of-population/> doi:10.23670/IRJ.2017.82.4.028

*Majidova Z.A.
teacher of department of foreign languages
faculty of agro engineering and hydro melioration
Andijan Institute of Agriculture and Agro technologies,
Andijan, Uzbekistan*

THE STAGES OF DEVELOPMENT OF E-LEARNING, TECHNOLOGIES OF DISTANCE LEARNING

Annotation: The article considers the stages of development of e-learning, technologies of distance learning. The analysis of software requirements for e-learning is carried out. ICTs develop the parameters of the educational sphere with various programmable technologies and ways of improving students. Also disassembled various software and methodological complexes.

Key words: e-learning, distance learning, technologies of e-Learning, education, computer, formation, factors.

Recently, the concept of e-Learning has become widespread in the world, meaning the process of learning in electronic form through the Internet.

The transition from the traditional form of education to teaching based on computer technology took place over two decades. Since the emergence of large archives located on machine-readable media, the idea of using this material for educational purposes has appeared more and more often.

To a greater extent, such a transition became possible with the development of the global Internet, which made it possible to send any amount of data over long distances, freely communicate with network users online, post information on the Internet, thereby making it available to everyone.

The stages of development of e-learning can be represented in the following sequence:

- 1) courses on CD-ROMs;
- 2) distance learning;
- 3) e-learning technology

Each of the subsequent stages includes the technologies of the previous one. Historically, CD-based courses were the very first. Their main advantages were: an innovative idea, presentation of thematic information on a machine-readable medium, methodologically well-organized training, interactive opportunities, ease of use, accessibility.

As disadvantages, we can note: the limited course, the complexity of creation, the lack of the possibility of modification.

The next stage - distance learning, which represents a different educational approach, made it possible to eliminate the above disadvantages and thereby brought a number of additional opportunities to e-learning. In distance learning,

the basis of the educational process is the purposeful active independent work of the student, who has the opportunity to gain knowledge in a convenient place for himself, at an individual pace, with the available set of special teaching aids with the ability to contact the teacher.

Distance learning is characterized by the following positive aspects: flexibility of the training schedule, an individual learning path that matches your own needs and capabilities; an objective methodology for assessing knowledge, independent of the teacher.

In turn, this form of training also gives teachers additional opportunities to provide students with educational material, i.e. it becomes possible to reach a larger number of students without increasing the load. It becomes obvious that with all the advantages noted, distance learning quickly gained immense popularity in the educational environment. Large corporations have gradually become interested in this form of training, rightly noting that distance learning will allow them to quickly, efficiently and relatively inexpensively, and also, importantly, improve the qualifications of their personnel without interrupting production.

Distance education is a rather popular and promising form of education. To use it as efficiently as possible, a theoretical and technical base of the appropriate level is required. And also an important role in the success of the educational process is played by the interest of the participants in this form of education.¹³ [1]

The use of the Internet in education, the variety of topics of online courses, ways of their implementation have led to the emergence of a broader term "e-Learning".

The European Commission defines e-Learning as “the use of new multimedia and Internet technologies to improve the quality of learning by improving access to resources and services, as well as remote knowledge sharing and collaboration.”

Today, e-learning is understood as a form of education that uses interactive electronic means of providing information: CDs, local area networks, the global Internet. Solving its original task of learning remotely via the Internet, e-Learning technology is also an excellent additional means of full-time education and can be a good way to improve the quality of training in the traditional form of education.

The technology used is the effectiveness of distance learning. The capabilities and characteristics of the distance learning technology used are aimed at ensuring the maximum possible efficiency of interaction between the teacher and the learners within the framework of distance learning.

The main groups of e-learning tools are:

- ❖ authoring software products (Authoring Packages);
- ❖ content management systems (CMS);

¹³ X. Alimova. Modern methods of using information technologies in lessons //Economy And Society. № 6(73) - S.: 2020.

❖ Learning Management Systems (LMS);

LMS Moodle is a tool environment for developing both individual online courses and educational websites. The project is based on the theory of social constructivism and its use for teaching.

The system can create and store electronic educational materials and set the sequence of their study. Due to the fact that access to Moodle is carried out via the Internet or other networks, students are not tied to a specific place and time, they can move through the material at their own pace from anywhere in the world. The electronic format allows using not only text but also interactive resources of any format as a “textbook”. All course materials are stored in the system, they can be organized using labels, tags and hypertext links.

Moodle is focused on collaboration. The system provides a lot of tools for this: wiki, glossary, blogs, forums, workshops. At the same time, training can be carried out both asynchronously, when each student studies the material at his own pace, and in real time, by organizing online lectures and seminars. The system supports the exchange of files of any format - both between the teacher and the student, and between the students themselves.¹⁴ [2]

Moodle creates and stores a portfolio of each student: all submissions, teacher grades and comments, forum posts. Allows you to control the "attendance" - the activity of students, the time of their academic work in the network. As a result, the teacher spends his time more efficiently. It can collect statistics on students: who downloaded what, what home buildings they made, what test scores they got. Thus, to understand how the students understood the topic, and with this in mind, offer material for further study. Moodle has solutions for all possible learning management tasks. If there is no ready-made solution yet or it is imperfect, the functionality of the system can be easily expanded.¹⁵ [3]

List of references:

1. X. Alimova. Modern methods of using information technologies in lessons //Economy And Society. № 6(73) -S.: 2020.
2. Aldashev I. Use the specific properties of the computer, allowing you to individualize the educational process and turn to fundamentally new cognitive means //Economy And Society. № 6(73) -S.: 2020.
3. Qodirova G.T. The use of computers to improve the professional level of teaching and learning//Economy and Society. № 6(73) -S.: 2020.
4. Gulomjonova M. Introduction Of Remote Learning Technologies In Organization Of The Educational Process Of Higher School. International journal. Questions of science and education. 32(82). p.71.
5. UNESCO World Report on Communication and Information 1999-2000. - M. – 2000.

¹⁴ Aldashev I. Use the specific properties of the computer, allowing you to individualize the educational process and turn to fundamentally new cognitive means //Economy And Society. № 6(73) -S.: 2020.

¹⁵ Qodirova G.T. The use of computers to improve the professional level of teaching and learning//Economy And Society. № 6(73) -S.: 2020.

Makhammadjonov T.A.
assistant of the department of biological chemistry
Andijan State Medical Institute
Andijan, Uzbekistan
Makhammadjonova F.A.
Shahrixon tumani 28-maktab o'qituvchisi
Andijan, Uzbekistan
Tajiddinov S.S.
Peshku tuman Ekologiya va atrof
muxitni muxofaza qilish bo'limi inspektori
Bukhara, Uzbekistan

SUBJECT AND TASKS OF BIOLOGICAL CHEMISTRY

Annotation: This article discusses the goals and objectives of biological chemistry, the relationship of this science with other disciplines and the main directions of biological chemistry.

Key words: biological chemistry, disciplines, goals and objectives,

Biological chemistry is the study of chemical processes in all living organisms. These processes consist of the constant exchange of substances and energy in the organism, its tissues and organs, the cell and its constituent structures. Before studying metabolism, it is necessary to get acquainted with the substances that change in the composition of different organisms. Biological chemistry is the study of the chemical structure and properties of proteins, nucleic acids, carbohydrates, lipids, vitamins and inorganic compounds, their distribution and location in various parts of the body, including the cell and its elements.

Biochemistry is the study of the structures, functions, and laws of synthesis of proteins, carbohydrates, lipids, nucleic acids, and other biomolecules. Molecules that differ in complexity and size are called biopolymers, and monomers are their constituent units. Each polymer biomolecule is made up of different units. For example, a protein polymer is made up of 20 different amino acids. Biochemistry is the study of the chemical properties of the most important biomolecules (and especially important enzyme-catalytic processes). This article provides a broad understanding of cell metabolism and the endocrine system. Other areas of biochemistry: genetic coding, protein synthesis, signals transduction in the transport process in the cell membrane. The main purpose of biochemistry is to understand the relationship of biological molecules to processes in living cells.

The main task of biological chemistry is to solve basic, general biological problems at the molecular level. One must not only know about ecosystems, but also be able to protect and use them.

Biochemistry consists of 3 sections:

- ❖ Static biochemistry.
- ❖ Dynamic biochemistry.
- ❖ Functional biochemistry.

Static biochemistry is the study of the chemical composition and properties of substances that make up a living organism. The main issues of this section are studied by bioorganic chemistry.

Dynamic biochemistry analyzes all the changes in the body, from the reception of substances to their release in the form of final products.

Functional biochemistry is the study of the chemical processes that take place in organs and tissues, depending on their function.

All branches of biological chemistry are interconnected and are parts of modern biochemistry. Biological chemistry is divided into human and animal biochemistry, plant biochemistry and microchemistry of microorganisms.

As biological chemistry is a field between biology and chemistry, it is based on the knowledge and ideas of the two sciences. This science emerged as a separate science at a certain stage of development of biological and chemical sciences. It is believed that the first understanding of biological chemistry began with the experiments of the famous French scientist Lavoisier (1743-1794) in the late eighteenth century. His classical research on oxidation and the role of oxygen in this process led to the discovery of the chemical basis of the "burning" phenomenon in the body. Lavoisier concluded that the reaction absorbs oxygen, releases carbon dioxide, and generates heat.

The great medieval scholar and physician Abu Ali ibn Sina (980-1037) in his work "Laws of Medicine" described the classification of chemicals used in medicine, the "fluidity" of the body and the substances in the urine. People's natural desire to understand the causes of diseases and to seek drugs against them has aroused interest in the processes that take place in living organisms.

Biochemistry is taking a new place in pharmaceutical practice. In particular, enzymes, which are biological catalysts, are used in industry for the synthesis of drugs (eg, steroid hormones). Prospective ways to produce natural medicines using genetic engineering are being considered. Knowledge of the biochemistry of microorganisms has made it possible to create convenient and cost-effective methods of industrial production of drugs such as amino acids, nucleotides, nucleosides, vitamins, antibiotics. Methods for rapid and specific analysis of drugs using enzymes as analytical reagents have been developed.

As in other fields of science, due to the expansion and deepening of the problems of biological chemistry, new branches have emerged and independent networks have emerged. In recent years, membrane biochemistry, neurobiochemistry, analytical biochemistry, quantum biochemistry and others have joined the ranks of enzymology, vitaminology, endocrinology. However, the fundamental changes that have taken place in the biological sciences over the last quarter of a century are due to the unprecedented success of genes, cells, protein

engineering, and biotechnology in general, born of molecular biology, molecular genetics, and the development of these wonderful fields.

Determining the relationship between the structure of molecules of proteins and nucleic acids and their biological function is one of the earliest but most important advances in molecular biology, the youngest branch of biology based on biochemical data.

Thus, modern biochemistry is on the verge of unraveling the deepest mysteries of life processes, solving the problems of protein synthesis, metabolism and offspring management. The solution of these important tasks provides a theoretical basis for solving the most serious human problems, such as cancer, viral diseases, hereditary diseases and cardiovascular diseases, prolonging human life.

Biochemical research and their methods. Since the work of biochemists is related to living objects, they will have to use high-level methods to isolate a substance, perform a number of additional processes to carry biological molecules to the usual physicochemical analysis. The order of processes in the separation of substances from biological material is approximately as follows:

1. Homogenization.
2. Ultracentrifugation.
3. Extraction.
4. Analysis (re-extraction, heat treatment, dialysis, sedimentation, electrophoresis, chromatography).

Biological chemistry is derived from a number of mixed sciences, which still maintain an integral relationship with them in the study of living nature, but at the same time remain a unique and independent science, and the relationship between the structure of substances and their functions. , the study of the exchange of chemical compounds in living organisms, the formation of energy in living systems, the mechanisms of control of physicochemical processes in organisms, tissues, cells, molecular mechanisms of transfer of genetic information in living organisms, etc. function.

References:

1. R.A. Sobirova, O.A. Abrorov, F.X. Inoyatova, A.N. Aripov, "Biological chemistry ». New Generation, 2006
2. <https://hozir.org/>
3. <https://uz.wikipedia.org/>

UDK 004.02:004.5:004.9

DOI 10.46566/2225-1545_2020_1_79_163

Mamajonova G.A.

Senior Lecturer

Department of General Technical Sciences and Labor Education

Andijan State University

Kholmatova M.A.

teacher

Saidnazarova T.M.

Andijan State University

Department of General Technical Sciences and Labor

HISTORY OF TECHNOLOGICAL SCIENCE AND DEVELOPMENT STRATEGY

Annotation: this article provides information about the formation and history of technology as a science, the development strategy of technology, the innovations that have been and are being implemented in science.

Keywords: technology, technological means, new technologies, history of technology, evolutionary stage of technology, tools, processing methods, automatic control, adjustment systems, computing technology, information technology, technology development period, technology development.

"Technology" is a scientific discipline that develops and improves the methods of obtaining, processing and processing of materials or semi-finished products. According to historical sources, the science of "Technology" also appeared in ancient Greece. During this period, this meant that the artisan achieved the art of making things, under the guidance of his master (through practice), through his own diligence and natural ability.

The emergence of "technology" as a science - in the XVII century, the emergence of industrial production led to the rapid development of metallurgy, machinery, including industrial equipment, steamships, locomotives, firearms. The production of such complex and labor-intensive machines and equipment could be organized only on the basis of clearly developed technological documentation of the technological process. These documents describe the complex processes of obtaining, processing, processing ways and means of raw materials, semi-finished products and products, which are interrelated, sequential and precise actions, operations, and the achievement of the planned result are given. This will be the basis for expanded and mass production. In our time, technology is understood as the art of doing a certain thing. In order to master it, it is necessary to study the technological documentation in detail.

Before humanity was formed into a nation and a people, it began to engage in labor. While labor and profession were initially considered the mainstay of

survival, as the later stages of development took root, the profession also began to be pursued for material gain. Even in the tenth century, the development of special industries, the development of industries that could provide large populations with the necessary items, is a clear proof of this. This field has been developing in huge countries for many centuries. Historically, in the IX-XII centuries, handicrafts developed especially widely at a time when the economic ties of our people with foreign nations were growing. According to historical sources, the inhabitants of the so-called urban areas were engaged in 32 different trades. At the time of the first census in 1897, most of the major cities in the country were:

- 64% of the population of Namangan;
- 52% of Kokand;
- 54% of the population of Chust;
- 50% of the population of Margilan were independent professionals.

In the XII-XV centuries in Movaunnakhr and Khorasan the science of craft and its development reached a high level. In particular, the archeological excavations carried out in our republic show that the field of handicrafts developed in our region two thousand years ago, during which time handicrafts became an independent branch among the largest division of labor. Crafts such as blacksmithing, jewelry, coppersmithing and tin-making have been the most widespread since ancient times, and one of the most widespread ancient crafts is woodworking, which is practiced in many ancient cities of the country, including Bukhara, Khorezm and Samarkand. is still preserved and passed down from generation to generation. Doppidoz (hat betting) is also one of the professions that is deeply rooted in the blood of the Uzbek people and enriched with new ideas in the modern world. In addition, there are various professions made of leather, shoemaking, baking, confectionery, butchery, culinary professions formed on the basis of large weddings, which have been formed and developed for many years. In the early twentieth century, as a result of technological advances, a new craft - sewing - emerged on the basis of the emergence of sewing machines.

Therefore, the demand for vocational training and vocational guidance has existed for a long time, and the history of this science dates back to the distant past (in the 3rd millennium BC). At that time, graduates of the Babylonian school of scribes were tested and assigned to positions based on their level of education. Mirza, a well-trained man, was a central figure in Mesopotamian civilization: he measured fields, divided property, played musical instruments and sang.

Different countries had different methods of vocational guidance and testing. In Egypt, recruits were interviewed and their biographies, education, appearance, and communication skills were tested. Thus, the acquisition of a profession and vocational training has long been considered important, but officially professional counseling agencies began to appear at the beginning of the century.

Historically, one of the first decrees of the former Soviet Union on public education - the "Regulations on the Unified School of Labor" - considered labor education as an important factor in education, the full development of the individual. In addition, in recent years, serious attention has been paid to the vocational guidance of the younger generation, and a number of laws have been implemented to develop the teaching of labor education. In 1977, "On further improving the education and training of secondary school students," in 1984, "On improving labor education, training of schoolchildren, their training in career choice." "On the organization of socially useful, productive work."

Approved by the former Soviet government in April 1984 and implemented in practice, the "main directions of the reform of general education and vocational schools" were aimed at improving the efficiency and quality of labor training of students. The reform envisages a doubling of the number of hours devoted to the training of students, the establishment of a common profession in schools, and as a result, students will be able to take one of the public professions before starting work, as well as career choice. slightly increased demand.

During the years of independence, the country has undergone significant changes in the field of education, on the basis of the laws "On Education", "National Training Program" manuals and other manuals were created. A number of research and pedagogical scientists in the country are studying the introduction of pedagogical technologies in the educational process. The First President of the Republic of Uzbekistan I.A. Karimov stressed that "providing the educational process with advanced pedagogical technologies" is an important task in the implementation of the National Program. The organization of the process of technological science plays an important role in the system of continuing education in the country in the implementation of the social order for the training of competitive professionals in various fields, the creation of conditions for their acquisition of high knowledge and skills, the organization of highly qualified specialists in the production process. If we analyze the education system of a number of developed countries today, we can see that serious attention is paid to technical processes. The development of our country depends on the sphere of production, the development of the sphere of production depends on the qualifications of specialists.

It is the combination of intellectual and physical knowledge, skills and abilities of students in the field of technology and the development of sensory skills in technical work, as well as the world of professions, difficulties and disparities in choosing a profession, factors to consider when choosing a profession. information about is given as the main goal of science. This means that the focus on the science of technology will allow not only technical colleges, but also young people to make a conscious choice of their profession, taking into account all aspects. By increasing the interest of students who have chosen the right profession, that is, by improving the quality and effectiveness of education, we will be able to train mature, world-class professionals. These specialists

directly contribute to the development of the country by developing production processes.

It can be said that the purposeful use of modern educational technologies and tools in the organization of technology lessons, the introduction of innovative pedagogical technologies will increase students' interest in science, to have a clear idea of the implementation of the objects of labor in practical training. It opens up a wide range of opportunities for the formation of in-depth knowledge, skills and competencies in the conduct of labor operations.

Today, developed countries around the world are moving from agricultural production to industrial production, that is, to a state of automated industrial production based on new techniques and technologies. The technical potential of specialists plays an important role in the development of production. The basic skills of manufacturing professionals are taught in technology classes in general secondary schools.

References:

1. Muslimov N. et al. Technology of formation of professional competence of teachers of vocational education. - T.: "Science and Technology". 2013
2. Bekmurodova S. A new approach to teaching technology. Methodical Manual. Ò.: RTM, 2017.
3. Karimov I. Technologies of labor education teaching. Ò.: TDPU, 2013.
4. Muslimov N.A., Sharipov Sh.S., Qoysinov Î.À. Labor education teaching methodology, career guidance. Textbook. Ò.: TDPU, 2014.
5. Sharipov Sh.S., Qoysinov Î.À. et al. Teaching technology and the use of innovative technologies in the organization of psychological services.

Mamatov R.R.
assistant of the department of Uzbek language, pedagogy and
physical culture
Andijan Institute of Agriculture and Agro technology
Uzbekistan, Andijan

USING INFORMATION TECHNOLOGY AND EDUCATIONAL ELECTRONIC RESOURCES WHILE PLANNING A FOREIGN LANGUAGE LESSON

Abstract: Each lesson should ensure the achievement of practical, educational, educational and developmental goals through solving specific problems. Therefore, the first thing a teacher should start with is defining and formulating lesson objectives based on the teacher's book.

Key words: educational standards, quality of education, innovative activity of the higher education.

A lesson is the main link in the learning process, in which the solution of specific practical, educational, educational and developmental tasks is carried out, ensuring the achievement of final goals. The peculiarity of the FL lesson is that it is not an independent unit of the educational process, but a link in a chain of lessons. In this cycle of lessons, the dynamics of the educational process is carried out: what was the goal of the previous lesson becomes a means of the next one, which determines the close relationship of lessons and ensures progressive movement towards the final educational goals¹⁶

A foreign language lesson has its own specifics, which is determined by the very content of the subject, the practical orientation of teaching and the fact that a foreign language acts not only as a goal, but also as a means of teaching.

Planning is an essential part of the job. In the field of teaching a foreign language, the objectives of the program can be achieved only with regular work according to a strictly planned and thoughtful plan.

Each lesson should ensure the achievement of practical, educational, educational and developmental goals through solving specific problems. Therefore, the first thing a teacher should start with is defining and formulating lesson objectives based on the teacher's book. In it, as a rule, practical tasks are formulated, which can easily be given a specific look by linking them with certain linguistic material, for example:

- train students in the use of new vocabulary (words are indicated);
- to learn to perceive by ear a dialogical text (text is indicated);

¹⁶ Irgashev M.U. Modern pedagogical technologies as a resource of the modern lesson, ensuring the development of educational standards. International scientific journal. Economy and society. № 6(73) -s.: 2020.

- teach to conduct a conversation on a topic (the topic is indicated);
- to systematize students' knowledge of prepositions (prepositions are listed);
- teach students to read to themselves and make a plan for the text they read;
- teach to express your opinion using the following expressions (listed);
- learn to read the text based on guesswork, etc.

Planning a foreign language lesson using new information technologies requires compliance with certain didactic principles and scientific and methodological provisions, formulated in traditional didactics and filled with new content thanks to information technologies.

Planning a foreign language lesson should be considered:

as an element of the general training system;

as a single whole, consisting of many components of the learning process (teacher, student, educational information tool, educational material).

We must not forget that a lesson in terms of its goals and didactic structure is a very mobile and rather flexible form of organizing classes, it is in constant development and changes depending on the availability of a material base and the emergence of new educational electronic resources. Therefore, taking into account the principle of development into a projected lesson the possibility of constant expansion and renewal of its system of tasks (developing, teaching, educational) and means of achieving them should be laid.

The use of NIT in foreign language lessons in the educational process fundamentally changed the approach to assessing the information skills of a teacher, which until recently were mainly associated with the ability to transmit information to students. Today, the level of information skills of a foreign language teacher is determined not only by communication skills, but also by the ability to use a computer as a source of information. From this point of view, the level of formation of analytical, predictive and projective skills of a foreign language teacher is very important, aimed at assessing the quality of educational electronic resources (OER) and the effectiveness of their application in the educational process. The information presented in the OER should be assessed based on the general didactic principles of scientific nature and the availability of its presentation, the possibility of adaptation to the individual capabilities of the student, etc.

Often the overload of the content of the OER, the abundance of secondary material lead to the loss of the main one among the unimportant details. Therefore, when preparing for a foreign language lesson and analyzing the OER, it is necessary to select and use information, highlighting the primary, backbone, focusing the attention of students on basic concepts and laws.

Thus, the use of information and communication technologies (ICT) in foreign language lessons is quite relevant for the development of the student's

personality and the formation of information and communication competencies in students: the ability to compare the advantages and disadvantages of various sources of information, choose the appropriate technologies for its search, create and use adequate models and procedures for studying and processing information, etc.

The effectiveness of personality development is directly proportional to the individualization of students' activities during training. In the pedagogical process based on ICT tools, the principle of individualization is implemented primarily through the hypertext technology of presenting unstructured free growing knowledge. Unlike other models of information presentation, hypertext technology is focused on processing information not instead of a person, but together with a person, i.e. becomes copyright. The convenience of its use lies in the fact that the student himself determines the approach to the study or creation of material, taking into account his individual abilities, knowledge, level of training. In addition, hypertext contains not only information, but also mechanisms for its effective search.

Thus, hypertext is associated with the real possibilities of building an education system based on NIT tools, which makes it possible to radically change the methods of obtaining new knowledge through a more effective organization of the cognitive activity of students, which will undoubtedly contribute to the consciousness and activity of students.

Long-term pedagogical experiments show that the effectiveness in the development of creative abilities of students also directly depends on the use of the opportunities and means of their self-government. Everything that schoolchildren in the course of educational activities are able to do without outside help, they must do on their own. To a large extent, this principle is realized only when using information technology.

A foreign language lesson is a complete piece of work on training, during the cat. the achievement of certain practical, general educational and educational goals is carried out. Achievement of these goals is carried out by performing pre-planned individual and individual-group tasks based on the means and teaching methods used by the teacher. The essence of the lesson lies in its speech orientation.

When planning a lesson, the teacher should be especially careful about its initial stage. The success of the whole lesson and the psychological mood of the class depend on how brightly, unconventionally he starts the lesson, how easily he "introduces" the students into the atmosphere of foreign language communication.

References:

1. Irgashev M.U. Modern pedagogical technologies as a resource of the modern lesson, ensuring the development of educational standards. International scientific journal. Economy and society. № 6(73) -s.: 2020.

2. Mamatov R.R. A. The quality of higher education as an object of systemic research: lecture-report. Moscow: Research Center for the Problems of the Quality of Specialist Training, 2002.

3. Vostrikov AS et al. Quality management system in a technical university: Experience of the Novosibirsk State Technical University // University Management: Practice and Analysis. 2003.

*Matkarimova G.
teacher of department of foreign languages
faculty of agro engineering and hydro melioration
Andijan Institute of Agriculture and Agro technologies
Uzbekistan, Andijan*

ANALYSIS OF PEDAGOGICAL ACTIVITY IN CONDUCTING DIDACTIC GAMES IN ENGLISH LESSONS IN ORDER TO INCREASE INTEREST IN THE SUBJECT

Abstract: From variety of methods, methods of stimulating and motivating learning are distinguished into a special group. A valuable method of stimulating interest in learning is the method of using various games and game forms of organizing cognitive activity.

Key words: pedagogy, education, game, didactic, methods, students, pupils, to play, teaching.

Learning is the most important and most reliable way to get a formal education. Reflecting all the essential properties of the pedagogical process (two-sidedness, focus on the all-round development of the personality, the unity of the content and procedural sides), teaching at the same time has specific qualitative differences [2, 156].

Learning, like any other process, is associated with movement. It like an integral pedagogical process, has a task structure, therefore, movement in the learning process goes from solving one educational problem to another, advancing the student along the path of knowledge: from ignorance to knowledge, from incomplete knowledge to “transfer” of knowledge, skills and abilities, because learning is a two-way process in which teachers and students interact closely: teaching and learning.

Didactic games are a type of games with rules specially created by pedagogy in order to teach and educate learner. As mentioned above, games are aimed at solving specific problems of teaching students, but at the same time, the educational and developmental influence of play activities is manifested in them. The need to use didactic games as a means of teaching pupils at secondary school age is determined by a number of reasons:

1) Play activity as a leader has not lost its significance. One can agree with Lev Semenovich Vygotsky, who wrote that “at school age, the game does not die, but penetrates into relations with reality. It has its own internal continuation in school education and work.” Hence it follows that reliance on play activity, play forms and techniques is an important and most adequate way of involving learners in educational work.

2) The mastering of educational activity, the inclusion of learners in it is slow (many learners do not know at all what “learning” is).

3) There are age characteristics of learners. Associated with insufficient stability and voluntary attention, mainly the involuntary development of memory. The predominance of the visual-figurative type of thinking. Didactic games just contribute to the development of mental processes in learners.

4) Insufficiently formed cognitive motivation. The main difficulty in the initial period of education lies in the fact that the motive with which the pupil comes to school is not related to the content of the activity that he must perform at school. The motive and content of educational activities do not correspond to each other. The content that the pupil is taught at school should encourage learning. There are various difficulties in adaptation when a learner enters school (mastering a new role - the role of a student, establishing relationships with peers and teachers).

The use of the potential of play in pedagogical work is largely associated with the professionalism and creativity of the teacher himself. In order to successfully organize learners's games, he must have a kind of "sense of play", developed creative imagination and, in addition, a certain amount of knowledge and practical skills in the field of methodology of play. It is this knowledge that is lacking for most teachers working with learners of primary school age. Therefore, the success of the development, teaching and upbringing of primary schoollearners in general, as well as the final result of the professional activity of teachers will depend on how fully they will be prepared for:

- developing an optimal strategy and tactics for including play in the lesson and its use in extracurricular and extracurricular work with learners;
- conducting a psychological and pedagogical examination of games, a prospective and final analysis of their impact on various aspects of learner development;
- creative arrangement of traditional and design of new, “pedagogical” games, design of integral game programs.

The value of the game in the psychological and pedagogical context is obvious, however, the teacher does not ignore its absolute right in the life of student, that is, towards it with some caution, distrust, and apprehension. One of the main and common reasons for this position is the mistaken belief that the school is intended to teach, not play with him, which is equivalent in their view. The fact remains - a significant part of the teacher is not ready and does not know how to play with their students, it is easier and more convenient for them to teach them. Thus, at school there is a problem of increasing interest in learning, in particular, in the English language, which is one of the most difficult and by no means the most interesting.

Practical work was carried out on the basis of the theoretical approaches of advanced teachers and psychologists to solving the problem of increasing interest in English language lessons among learners, relying on the pedagogical

conditions for organizing and conducting games in English language lessons, which enhances interest in this subject. In the course of practical work, the following diagnostic techniques were carried out:

- Monitoring student activities;
- Conversation with the teacher;
- Questioning among students, who helped to identify the presence of this problem in the classroom and track the results obtained in the course of conducting and organizing lessons.

Education should be developmental, aimed at the formation of the cognitive interests and abilities of students. In this regard, playful forms of learning, in particular, didactic games, are of particular importance.

Didactic games provide an opportunity to develop in students the arbitrariness of processes such as attention and memory. Game tasks have a positive effect on the development of ingenuity, resourcefulness, ingenuity. Many games require not only mental, but also volitional efforts: organization, endurance, the ability to follow the rules of the game.

The main thing is that the game is organically combined with serious, intense work, so that the game does not distract from the study, but, on the contrary, contributes to the intensification of mental work.

Bibliography:

1. Карпова Е.В. Didactic games in the initial period of study. Popular manual "Academy of Development", Yaroslavl, 1997.
2. Irgashev M.U. Modern pedagogical technologies as a resource of the modern lesson, ensuring the development of educational standards / - Journal: "Экономика и социум" -М., №6(73) 2020.
3. Babansky Yu.K., Slastenin V.A., Sorokin I.A. and others. Pedagogy: a textbook for students of pedagogical institutes / Education, Moscow, 1988.
4. Podlasy I.P. Pedagogy: a textbook for students of higher pedagogical educational institutions, Education Humanitarian publishing center VLADOS, 1996.

*Mukhammadiyeva Kh.K.
Department of Pedagogy of Primary Education
The Faculty of primary education and physical training
Teacher of the
Tashkent State Pedagogical University named after Nizami*

DEVELOPING INTELLIGENCE IN PRESCHOOL CHILDREN THROUGH THE USE OF PERSON-CENTERED TECHNOLOGIES

Abstract: What today's children will be like tomorrow depends in many ways on how this period, called childhood, went, and what it brought into the mind and heart from the environment. we provide feedback on the development of intellectual development in preschool children and a positive study of world experience.

Keywords: research, constructor, nervous system, plot, enlightenment, scientific observation, principles of child rearing, pedagogical approach.

*Мухаммадиева Х.К.
Бошлангич таълим педагогикаси кафедраси
ўқитувчиси
Низомий номидаги ТДПУ “Бошлангич таълим” факультети*

ШАХСГА ЙЎНАЛТИРИЛГАН ТЕХНОЛОГИЯЛАРДАН Фойдаланиш орқали мактабгача таълим ёшидаги болаларда интеллектуаллигини ривожлантириш

Аннотация: Бугунги болаларнинг эртага қандай инсон бўлиши кўп жиҳатдан болалик деб аталган бу даврнинг қандай ўтгани, унинг онги ва қалбига атроф-муҳитдан нималарни олиб кирганига боғлиқдир. мактабгача таълим ёшидаги болаларда интеллектуаллигини ривожлантириш фикр мулоҳазалари ва жаҳон тажрибасини ижобий ўрганган ҳолда мулоҳаза чиқарамиз.

Калит сўзлар: тадқиқот, конструктор, нерв системаси, сюжет, маърифат, илмий кузатиш, бола тарбияси принциплари, педагогик қараш.

Дунё миқёсида мактабгача таълим ва тарбиянинг инновацион моделларини ишлаб чиқиш, амалиётга жорий этиш, педагог-тарбиячиларни инновацион фаолиятга тайёрлаш, тарбияланувчиларнинг интеллектуал, эстетик ва жисмоний қобилиятларини ривожлантириш бўйича тадқиқотлар алоҳида аҳамиятга моликдир. Шу жиҳатдан мактабгача таълим-тарбияда унинг мазмуни, усуллари ва воситаларини инновацион ривожлантириш мақсадида вариатив ёндашув асосида дастурлар, креатив технологияларни ишлаб чиқиш педагог-тарбиячиларнинг ижодкорлик ва технологик компетентлигини такомиллаштириш заруриятини изоҳлайди. Дунё таълим

тизимида шахсга йўналтирилган технологиялардан фойдаланиш, таҳсил олувчиларнинг нодир иқтидорини намоён этишларига кўмаклашиш муҳим аҳамият касб этмоқда. Болаларни шахс ва субъект сифатида шакллантириш, уларнинг ақлий, руҳий ривожланиши, маънавий-ахлоқий, эстетик ва жисмоний тарбияланишига доир масалаларни ҳал этишга алоҳида эътибор қаратилмоқда.

Жаҳондаги ривожланган мамлакатлар АҚШ, Россия, Жанубий Корея кабиларда мактабгача таълим ташкилотлари фаолияти самарадорлигини замонавий талаблар асосида ташкил қилиш ва бошқариш, педагог кадрларнинг компетентлигини ошириш, мактабгача таълим тизимида олиб борилаётган ислохотларнинг умумий жараёни билан ўзаро алоқадорлигини белгилайдиган дидактик омилларни аниқлашга йўналтирилган кенг кўламдаги тадқиқот ишлари олиб борилмоқда. Ушбу тадқиқотлар замирида давлат ва нодавлат мактабгача таълим ташкилотларини ташкил қилиш, мактабгача таълим тизими ходимларини тайёрлаш, қайта тайёрлаш, малакасини ошириш, танлаб олиш ва ривожлантиришга мутлақо янги ёндашувларни қўллаш масалалари етакчилик қилмоқда. Шунингдек, мактабгача таълим ташкилотлари тарбияланувчиларини шахсга йўналтирилган технологиялар асосида дидактик жараёнлардаги фаоллигини таъминлаш, уларни мактабга тайёрлаш услубларини такомиллаштириш ва ижтимоийлаштириш масалалари алоҳида долзарблик касб этмоқда.

Мамлакатимизда сўнгги йилларда мактабгача таълим ташкилотлари фаолиятини мониторинг қилиш, педагог кадрларнинг салоҳиятини ошириш, тарбияланувчиларда шахсий фазилатларни таркиб топтириш, мактабгача таълим соҳасида болалар қамровини ошириш бўйича кенг қамровли ислохотлар амалга оширилди. Шунингдек, мактабгача таълим ташкилотсидаги дидактик жараёнларда боланинг ривожланиши ва ижтимоий мослашишини таъминловчи шахсга йўналтирилган технологияларни такомиллаштириш вазифалари муҳим аҳамият касб этмоқда. Шу билан бирга, болаларни мактабга тайёрлаш, тарбияланувчиларнинг интеллектуал, руҳий, эстетик, жисмоний, маънавий ривожланишини таъминлашнинг назарий-методологик асосларини такомиллаштириш эҳтиёжи сезилмоқда.

Ўзбекистон Республикаси Президентининг 2016 йил 29 декабрдаги ПҚ-2707-сонли, 2017 йил 30 сентябрдаги ПФ-5198-сонли Фармони, 2017 йил 9 сентябрдаги ПҚ-3261-сонли қарори, шунингдек Мактабгача таълим вазирлигининг 2018 йил 18 июндаги 1-мх сонли “Илк ва мактабгача ёшдаги болалар ривожланишига қўйиладиган давлат талаблари” ҳамда “Илк қадам” дастури ва бошқа шу каби ҳуқуқий-меъёрий ҳужжатларда акс этади.

Шахсга йўналтирилган технологиялардан фойдаланиш орқали мактабгача таълим ёшидаги болаларда интеллектуаллигини ривожлантириш ўзига хос хусусиятларга эга.

Маълумки, интеллект- (lot. “intellects” — билиш, тушуниш, идрок қилиш) — инсоннинг ақлий қобилияти, борлиқни онгда айнан акс эттириши, дунёни билиш ва ижтимоий тажрибани қабул қилиш қобилиятидир. Демак, мактабгача таълим ташкилотлари тарбияланувчиларини интеллектуал ривожлантириш деганда, уларнинг фикрлаш, ўқиш, ўрганиш, турли масалаларни ақлан ҳал этиш, теварак-атрофни объектив англаши тушунилади.

Тажрибавий машғулотларда шахсга йўналтирилган технологиялардан фойдаланиш орқали мактабгача таълим ёшидаги болаларда интеллектуал қобилиятларни ривожлантириш ишлари мунтазам олиб борилиши кузда тутилади. Бунда дидактик топшириқлар орқали болалар диққатини ривожлантириш муҳим аҳамият касб этади. Болалар диққатининг турғунлиги, кўчувчанлиги, бўлинувчанлиги каби хусусиятларни инобатга олиб, улар ақлий ривожланишини амалга ошириш мумкин бўлади. Маълумки, мактабгача таълим ёшидаги болалар бир фаолиятда диққатини ўзоқ ушлай олмайдилар. Диққатни кўчириш - уни бир фаолиятдан иккинчисига ўткази олишидир. Диққатнинг бўлинувчанлиги бир вақтнинг ўзида боланинг икки ёки ундан кўпроқ нарса билан шуғуллана олишида намоён бўлади. Педагог болаларда ихтиёрий диққатни ривожлантиришга ҳаракат қилиши керак. Ихтиёрий диққат боланинг ўзи учун қизиқ бўлмаган фаолият билан шуғуллана олишини назарда тутати. Бироқ, бу болаларнинг ўз олдига мақсад қўя олишга ўргатади: бирор нарсани эслаб қолиш, ана шу мақсадни амалга ошириш воситаларини излаб топиш шулар жумласидандир.

Мактабгача таълим ёшидаги болаларда интеллектуал қобилиятларни ривожлантириш учун ўйинлардан фойдаланиш самарали натижалар беради. Чунки, мактабгача таълимда ўйин-боланинг асосий фаолият тури ҳисобланади. Мактабгача таълимда боланинг ҳаракат қобилиятлари ва психик жараёнларни мажмуали ривожлантириш вазифасининг амалга оширилишини максимал даражада таъминлашини инобатга олиб, ўзгарувчан ўйинлар мажмуаларини ишлаб чиқиш, уларнинг мазмуни, ҳаракат дастурларини шакллантириш ва алмаштиришга йўналтириш муҳимдир. Болаларда сенсор ва мотор таркибий қисмлар, уларнинг тизимидаги турли сатҳлари орасида ўзаро таъсир юзага келишини инобатга олиб, янги ҳаракат дастурларини ишлаб чиқиш муҳимлиги тажриба мобайнида ишлаб чиқилган тавсияларда ўз аксини топди.

Фойдаланилган адабиётлар рўйхати

1. Мирзиёев Ш.М. Буюк келажакимизни мард ва олижаноб халқимиз билан бирга қурамиз. – Тошкент.: 2018 йил.
2. И.А.Каримов. Юксак маънавият – енгилмас куч, - Тошкент.: Маънавият. 2008 йил
3. Хайруллаев М.М. Маънавият юлдузлари. –Тошкент.: А.Қодирий номидаги халқ мероси нашри, 1999 йил.

Muxitdinova F.R.
teacher of department of foreign languages
faculty of agro engineering and hydro melioration
Andijan Institute of Agriculture and Agro technologies
Uzbekistan, Andijan

EXPERIMENTAL WORK ON USING NEW INFORMATION TECHNOLOGIES IN THE PROCESS OF LEARNING A FOREIGN LANGUAGE

Annotation: The process of informatization of education, supporting the integration tendencies of cognition of the regularities of subject areas and the environment, actualizes the development of approaches to the use of technical and didactic potentials of information technologies for the development of the student's personality, increasing the level of his creativity, developing the abilities for alternative thinking, the formation of skills for developing strategies for searching for educational and practical tasks.

Key words: informatization of education, development, program, foreign language, English lessons.

New multimedia technologies give a high effect of teaching a foreign language if they are supported by advanced teaching methods.

The main types of work with a personal computer (PC) in English lessons can be divided into two groups: the use of educational and cognitive programs on CD and the creation of programs in various applications by the teacher himself with further use in the classroom when explaining the material or when working out and checking it.

The use of educational and cognitive programs on CD is the most affordable way to use a computer both in the classroom and outside the classroom.

Language acquisition through play is one of the basic principles of the learning system. Various multimedia games help expand vocabulary, introduce you to English grammar, teach you to understand speech by ear, and write correctly.

Multimedia capabilities allow you to listen to speech in the target language, adapting it in accordance with your level of perception, and the regulation of the sound speed allows you to break phrases into separate words, in parallel comparing the pronunciation and spelling of words. Using a microphone and automatic pronunciation control allows you to correct your phonetic skills.

Each program contains a task, the desire to solve which creates a positive motivation for learning. The assimilation of educational material occurs without any outside motivation.

To work with the whole class, programs are used that assume the possibility of children's participation in the learning process. The teacher works at the keyboard, and the students jointly discuss the material that is displayed on the screen. Students during such a lesson are divided into groups where they work together, and the teacher, analyzing the conclusions made by them, enters the result into a computer.

Among the most successful programs of this type, it should be noted Triple Play Plus (Multimedia Teacher 3), released back in 1997. With its help, you can teach children listening comprehension, moreover, they learn to read, pronounce correctly at three levels, which makes it possible for the teacher to compare (in the presence of a microphone) the speech of students with the standard, as well as assimilate the analyzed voice to the characteristics of the speaker (choice - man / woman / child). The most successfully used part of the program is the physical description. Students are invited to create a composite of the person represented. With the help of a mouse or a microphone, you can assemble a portrait and work out all the vocabulary to describe the appearance. For a more complete development of the topic, the program has other interesting options for tasks and games. Performing an assignment on a drawing, which is a mosaic of parts of the human body, an extensive vocabulary is worked out. This disc contains material to describe the dwelling. With its help, prepositions are worked out. Students should find cards or household items located in the room (kitchen). The disc contains the following topics: Food and Drink; Numbers: Home and Office: Places and Transportation; People; Activities. There are three levels for each topic.

Among the most widely known programs on CD is the "Professor Higgins" CD recommended by the RF Ministry of Education. The program is designed for individual student work in phonetics and grammar. This disc has found application in the following types of work:

- Practicing phonetics (with a microphone) at the initial stage of training ..
- Setting the pronunciation of proverbs tongue twisters (with a microphone).
- Individual test on the studied grammatical topics, which vary in level of difficulty, allowing you to work out the same grammatical material with students of different grades, taking into account their preparation.

Euro Talk discs have, as stated, three levels: Elementary, Intermediate, Advanced. They are used for individual material development. The most interesting is the opportunity to issue students with an "international certificate", since when a certain number of points is collected, the program (if there is a printer) prints a certificate for the surname entered into the program, even with the signatures of the leaders of the Euro Talk group. It is convenient to use this disk in the early stages of training, first with the strongest students in the group.

At the senior stages, the Learn to Speak English program (2 CD) was successfully used for a comprehensive development of vocabulary topics. The

discs, consisting of 30 lesson topics, have a wide range of dialogues, exercises, games on these topics, as well as videos about US cities. Moreover, the teacher can demonstrate video clips with or without English subtitles. When using this program for two or three lessons, you can comprehensively work out the existing topics.

The use of training programs on CD in the process of teaching a language is the simplest, which does not require large expenses and serious preparation. Any teacher who knows how to work in the Windows operating system will be able to cope with them without any problems.¹⁷

The specificity of the subject of foreign language determines the active and appropriate use of the computer in the classroom. The leading component of the learning content of the foreign language is teaching various types of speech activities: speaking, listening, reading, writing. A training computer program is a simulator that organizes the student's independent work, controls it and creates conditions under which students independently form their knowledge, which is especially valuable, because knowledge obtained in a finished form very often passes by their consciousness and does not remain in their memory.

Self-creation of programs requires more serious preparation. They can meet a wide variety of requests. It is here that the individuality of a person, his vision of the material, manifests itself. These programs can be the main help in the work on teaching foreign languages. The teacher creates a presentation, taking into account specific students, their abilities, thus, student-centered learning is carried out.

The use of presentations in the classroom makes it possible to animate, change and highlight the most significant elements using color, font, tilt, size. So, for example, when explaining the formation of questions in English, students see how to gradually rebuild a sentence from a narrative to an interrogative one. If necessary, you can repeat this or that stage. In addition, photos, diagrams or tables can be added to the presentation, which further enhances the impact. With sufficient experience, creating a presentation in Microsoft Power Point takes an average of one to three hours, depending on the complexity of the material. In addition to Microsoft Power Point, teaching materials for use in the classroom can be created in Microsoft Word. Documents and templates are used successfully in teaching practice to test memorization of vocabulary. The presence of a speller at the computer in this case is not a facilitating factor, but an auxiliary means of teaching spelling correctness, as it enhances the processes of memorizing the visual image of lexical units.

Summarizing the experience of using a computer and multimedia technologies in foreign language lessons and after school hours, we can conclude:

- multimedia technologies accelerate the learning process:

¹⁷ X. Alimova. Modern methods of using information technologies in lessons //Economy And Society. № 6(73) - S.: 2020.

- they contribute to a sharp increase in student interest in the subject;
- improve the quality of assimilation of the material;
- allow you to individualize the learning process;
- make it possible to avoid subjectivity of the assessment.

The programs created by the teacher himself are not designed for any abstract student, but for those specific children whom the teacher teaches.

Thus, the introduction of computer technology creates the preconditions for the intensification of the educational process. They allow in practice to use psychological and pedagogical developments, providing a transition from mechanical assimilation of knowledge to mastering the ability to independently acquire new knowledge. Computer technologies contribute to the disclosure, preservation and development of trainees' personal qualities.

List of references:

1. X. Alimova. Modern methods of using information technologies in lessons //Economy And Society. № 6(73) -S.: 2020.
2. Qodirova G.T. The use of computers to improve the professional level of teaching and learning//Economy and Society. № 6(73) -S.: 2020.
3. Polat E.S. Internet at foreign language lessons // IYASH, 2001. - № 2. - p. 25 - 29.
4. Zakharova I. G. Information technologies in education: Textbook. manual for stud. higher. ped. study. institutions. M., 2003

L'EPOQUE DES LUMIERES EST UN RENNAISSANCE DE LA SOCIETE FRANÇAISE

Annotasiya: Fransiya davlati tarixi va fransuz adabiyotida Ma'rifat davrining o'ziga xos xususiyati va o'rni.

Kalit so'zlar: ma'rifat davri, adabiy oqimlar, fransuz ensiklopediyasi, qayta tug'ilish.

Actuellement, apprendre une langue étrangère est très important, la littérature est considérée le miroir du peuple. Apprendre la littérature, c'est apprendre la vie sociale du peuple..La littérature française se place aux premiers rangs dans la littérature du monde. Dans le monde il n'y a pas des gens qui ne connaissent pas la littérature française et les écrivains français. Beaucoup d'oeuvres et courants littéraires français sont devenus à leur façon des tournants et critères. Les idées qui y compris la littérature, sont influencées par les événements historiques, par la situation politique. Parce que la littérature est considérée le miroir de la mode de vie du peuple. Nous ne pouvons pas imaginer la littérature mondiale sans la littérature française et ses mouvements littéraires. Dans l'histoire de la littérature française nous pouvons raconter les mouvements littéraires. Chaque mouvement possède la importance historique.

J'ai analysé le mouvements littéraire « *les Lumières* » et ses représentants. Ce courant a une grande importance historique dans la littérature et dans l'histoire française. Parce que ce mouvement a reformé la littérature et la société française.

J'ai noté que ce mouvement est une grande histoire de l'histoire française. Parce que les philosophes des Lumières se servent des habitants pauvres français.

Je trouve que l'époque des Lumières est un rennaissance de la société française. Dans cette époque les représentants de ce mouvement a créé l'*Encyclopédie* est un recueil de 71 818 articles, répartis en 17 volumes. Cette œuvre qui est vendue à 25 000 exemplaires avant 1789, est un triomphe de la raison et du progrès pour permettre le bonheur humain.

Les *Philosophes* conseillent une conception démocratique de l'instruction et ils défendent également l'idée de l'égalité devant l'impôt. Je crois que c'est un grand succès des français dans l'histoire.

Dans cette époque les représentants de ce courant ont composé premierement les dictionnaires linguistique, philosophique et l'*Encyclopédie* française.

D'après moi, ils ont dénoncé en particulier la torture, l'esclavage et la peine de mort, dans son *Dictionnaire Philosophique*. Pour lui, il faut organiser la vie sociale selon les vraies valeurs terrestres, c'est-à-dire la propriété et la liberté humaine qui permettent le progrès. Il combat l'oppression intellectuelle et morale, en particulier la justice expéditive pour raison d'État.

J'ai l'impression que les idées des Lumières et leur conception de l'homme et de la société ont inspiré les bourgeois cultivés qui ont mené la Révolution française. Les régimes politiques qui suivent la Révolution: monarchie constitutionnelle, république, sont issus de leurs réflexions. Ces idées ont permis l'abolition de la torture et une plus grande équité dans la société française puis, à terme, à l'abolition de l'esclavage.

L'application violente des principes des Lumières ont également conduit au régime de la Terreur pendant lequel ont été commises des dizaines de milliers d'exécutions arbitraires, d'hommes, femmes et enfants qui ne partageaient pas l'idéal révolutionnaire. Leurs idées anti-religieuses ont mené à une tentative d'éradiquer l'Église et le christianisme dans son ensemble, au nom d'une conception matérialiste de l'homme.

J'espère que les représentants des Lumières ont fait tous les possibilités pour se développer au peuple français.

La bibliographie:

1. Encyclopédie I et Encyclopédie II (Garnier Flammarion)
2. Montesquieu, Lettres Persanes (lettres 12 à 14, 33...)
3. Voltaire, Dictionnaire philosophique (Égalité, Religion, Du juste et de l'injuste ...)
4. История французской литература: В 4-х томах. Том . – М.: Изд-во АН, 1976.
5. Мокульский С.С. Формирование классицизма // История французской литературы. т. 1, М – Л., Изд. АН СССР, 1946.
6. www.ccdmd.qc.ca.fr
7. www.françaisfacile.fr
8. www.google.fr

DIDACTIC OPPORTUNITIES FOR PROFESSIONAL SOCIALIZATION OF FUTURE PRIMARY SCHOOL TEACHERS

Annotation: The article provides an opportunity for primary school teachers to acquire the qualities of professional competence and approach through didactic methods. Develop the skills of young teachers in primary school. They should make recommendations on how to raise the quality and effectiveness of education to a new level, the introduction of modern teaching methods.

Keywords: Science, development, teaching aids, electronic didactic tools, pedagogical innovation.

In independent Uzbekistan, according to the "National Training Program" and the Law "On Education", it is a priority of the state as a structural and integral link. Indeed, the rapid growth of information due to the rapid development of science and technology has led to a high level of pedagogical and professional skills for the primary education system, which is the main foundation of continuing education. requires the training of creative teachers.

The ongoing educational reforms in our country, in contrast to traditional forms of education, have developed effective forms and methods of organizing the educational process in the primary education system, which serve to ensure the formation and development of young people as harmoniously developed individuals. output allows the creation of scientific views, pedagogical theories and didactic materials that lead to the optimization of the pedagogical and psychological foundations of education for children of primary school age. The Concept of Higher Education of the Republic of Uzbekistan defines the tasks of the specialist as follows: "The ability of the specialist to work in creative teams, training in management and marketing, economic development of new technologies, their social and cultural These ideas also apply to teachers, because the fundamental changes taking place in our society, our access to market relations, make the teacher aware not only of professional knowledge, but also of economic, legal and technical knowledge. It is also important to focus on the primary school teacher.

Professional skills of primary school teachers and requirements to them:

Textbooks, manuals, methodical recommendations, methods and mechanisms of organization of the educational process, created on the basis of the ideas recognized in the concept of primary education, the effectiveness of

education in primary school, depends on innovative ideas and tools of teaching, of course.

However, it should be noted that in this pedagogical process, the role of an elementary school teacher with high pedagogical skills and professional knowledge, who can create problem situations during the lesson and offer solutions, is of particular importance. If the primary school teacher pays more attention to the basic principles and general laws of the natural and social sciences, their place and importance in human society, the differential aspects of education, the primary school teacher - with methods a set of armed psychological knowledge, with a thorough knowledge of the scientific and theoretical foundations of mathematics, mother tongue, nature, human and social education, factors and means to increase the effectiveness of education, based on the age (physiological and psychological) characteristics of the child pays attention. aspects, i.e. integral learning. In addition, the primary school teacher should be able to control the direction of the child's play activities in the educational activities, to feel responsible, to make the right decisions in some problematic situations, to plan time, o He is also a responsible educator who teaches students. to form the qualities of attention to desires, as well as perceptions of a promising future, while appreciating goodness. Another important quality of an elementary school teacher is that he organizes his educational activities on the principles of the interdependence of primary and secondary education and the interdependence of primary education. Today, there are many problems in the work of primary school teachers in urban and district schools, including shortcomings in the use of non-traditional teaching methods in the teaching of private subjects in primary education; uncertainties in the assessment of students' knowledge; inability to feel the psychological state of students and consequently motivate them to the learning process; inability to provide interdisciplinary communication in the learning process; cases of non-compliance with didactic principles are not fully understood. It is impossible to talk about the quality and effectiveness of education in primary school without finding a positive solution to these problems.

The fact that in the former USSR there is a whole system of pedagogical colleges and educational institutions, which prepares teachers who teach students in grades 1-4, is evidence of the low assessment of primary education. However, the simple logic requires that the most mature and experienced coaches be hidden in an elementary school where the child's outlook, taste and potential are formed, "he said. part-time special sections were opened, the primary education system was enriched with modern textbooks and literature, didactic materials. However, this is not available in all schools. For example, some high schools have philologists or other graduates who do not know the methods of primary education. Another reason for the low level of knowledge of primary school teachers is the lack of training in higher education.

Potential primary school teachers cannot be taught special courses, such as "The modern concept of natural science", "A unique view of the structure of the

universe" or "Innovative pedagogical technologies", "Start on the basis of information technology." Organization of the educational process in the classroom "is a secondary subject. Young students turn to elementary school teachers with all their science and social science questions to help them understand the natural phenomena they see around them and the words they hear from adults with their curiosity about everything. High school students, unlike them, do not ask a physics teacher questions in mathematics or biology. This requires that primary school teachers are well versed in all areas of science. requires the provision of systematic knowledge in the field of interdisciplinary relations in the preparation of primary school teachers. To organize pedagogical activity, a teacher must master such disciplines as pedagogical theory, philosophy, sociology, cultural studies, religion, children's anatomy and physiology, psychology, and political science. The elementary grades also have a science subject and require knowledge of the laws of physics for the correct interpretation of phenomena does. It is also technologically advanced in the educational process today, development of an approach to cybernetics in teaching pedagogy.

Another important aspect is that the essence of the teaching profession and its role in the development of society, as well as the main features of the teaching profession are formed through the science of pedagogy. Designing the educational process in primary school teachers, mastering pedagogical technology, communicative qualities and research activities studies have explored low levels of skills at this level

The reasons for this should be as follows:

- Student team of future teachers during pedagogical practice lack of attention to individual communication with;
- lack of ability to design the learning process;
- interactive training of future teachers enough attention;
- Insufficient knowledge of the theory and practice of pedagogy

Training of primary school teachers based on experience and analysis and the following suggestions for optimizing the requirements for them We think the implementation is expedient.

Therefore, modeling the process of improving the system of preparation of students for the formation of social activity skills is based on the requirements that are important in the organization of the process of development of professional training, social activism of future primary school teachers.

It can be recommended as a template for the use of advanced methods, which reflects the stages and functions of the organization of the process, as well as the provision of feedback.

that is:

- Among the methods and approaches used in the development of knowledge, skills and abilities to improve the system of preparation of students for the formation of social skills, as well as the tasks performed in the formation of self-development skills 'ensure continuous integration;

- Targeted use of tools to shape and develop students' needs and interests and self-development skills to increase their social activism;

Such a gradual transition will both increase the professional socialization of teachers and allow young people to become educated.

Conclusion.

During the writing of this article, I came to the conclusion that we need to create the highest possible conditions for primary school teachers. The reason is that they prepare the next generation, ie young children, for life, on the other hand, they give them basic education. With this in mind, we need to provide them with a variety of teaching methods and improve their skills every year.

References:

1. Mirziyoyev Sh.M. We are determined to continue our path of national development step up / Volume 1 / - T.: NMIU of Uzbekistan, 2017.
2. Decree of the President of the Republic of Uzbekistan "On the Strategy of further development of the Republic of Uzbekistan". - T.: Adolat, 2017.
3. Abdulkarimov H., Jumayev A. Socially active and qualified competitor practical bases of personnel training. // Modern teaching, research and problems.

*Normamatov I.B.
researcher
of Karshi Engineering Economic Institute (KarEEI)
Uzbekistan*

REDUCTION OF EXTERNAL BANK CIRCULATION OF CASH AS A COMPULSORY CONDITION IN DEVELOPMENT OF PAYMENT BY CHEQUE IN COUNTRIES OF CIS

Annotation: External bank circulation of cash in countries of CIS serves as a source of deepening the inflation process so far as the main part of population's expenditures are paid with cash. At present distrust of economic agents to national bank system, promotes to widening of shady economics and external bank circulation in countries of CIS. Practically there exist some factors, creating unfavorable situation for efficient activities of commercial banks, as a result, these banks are simply becoming obliged to do a low qualitative service for their clients and by this way are losing confidence of the companies.

Today, one of the most actual problems of bank systems in countries of CIS, is that commercial banks are not performing in time the demands of their clients considering about obtaining cash devices.

Keywords: payment order, check, documentary letter of credit, clean collection, documentary collection, liquidity, commercial bank, overdraft, security, priority of payments.

External bank circulation of cash in countries of CIS serves as a source of deepening the inflation process so far as the main part of population's expenditures are paid with cash. At present distrust of economic agents to national bank system, promotes to widening of shady economics and external bank circulation in countries of CIS. Practically there exist some factors, creating unfavorable situation for efficient activities of commercial banks, as a result, these banks are simply becoming obliged to do a low qualitative service for their clients and by this way are losing confidence of the companies.

The results of the study by A. Yurov showed that, firstly, there is a direct relationship between cash circulation and the economy; secondly, improving the organization of cash circulation will lead to a reduction in non-banking cash circulation¹⁸.

¹⁸ Yurov A.V. Cash circulation during periods of recession and economic recovery // Money and credit. - Moscow. 2011. - No. 1. - pp. 37-45.

According to G. Panova, E. Valetdinova, ensuring the optimal balance between cash and non-cash money is important in reducing the volume of non-banking cash turnover¹⁹.

According to S. Meshchenko, the minimum cash growth was to serve the shadow sector in a stable economic situation and significant economic growth²⁰.

1. Non-observing the principles of bank secrets.

Though in many countries of CIS there exists the Law “About bank secrets” which must guarantee safety of information considering as a bank secret, commercial banks practically can’t observe the rule in most cases. Because law-keeping organs (courts, prosecutors’ offices) have full access to the information on bank accounts even in conditions such as not having attitude to excitement from criminal action. Besides that, local government bodies and collaborators of tax inspection can also acquire such information without specific efforts. Having information about bank accounts of clients, third persons can entirely use them for unconscientious purposes. Such a practice decreases the stimulus of many enterprises connected to bank and creating favourable climate for the introduction of shady business.

2. Strengthening the role of tax agents in banks.

On the base of existing a number of legislative acts, today commercial banks are obliged to do functions of tax organs. In the presence of clients by debts in budget and external funds, commercial banks in compulsory order transfer monetary devices from accounts of their clients for paying encashment charges of taxation and external budget funds. Such a practice is contrary to confidentiality of the facts of bank clients and by this way undermines the trust to banks.

3. Untimely performing of duties.

Today, one of the most actual problems of bank systems in countries of CIS, is that commercial banks are not performing in time the demands of their clients considering about obtaining cash devices. It is known when in economics of countries there exists still unrealized potential, presence of decreased inflation can stimulate economic growth, and don’t have negative effect to purchasing power of national currencies. However, if the index of inflation begins to grow in high level, say, for example, more than 20 % a year, it is already difficult to control and it tends to acquire chronic forms. As a result of high inflation, population doesn’t want to keep their savings in national currencies. Capital is used for purchasing “stable foreign currencies” and by this way the cost of national currency falls. Besides that, purchasing power begins to pass to the state, as well as it will use money, which are edited by central banks. This is inflation tax.

Elaborating effective money-credit and fiscal politics requires the exactness in the price of such key statistic indexes as the volume of output and the level of

¹⁹ Panova G.S., Valetdinova E.N. Limitation of cash circulation in the fight against the shadow economy // Vestnik MGIMO. - Moscow, 2014. –№1. – pp. 147

²⁰ Meshchenko S.V. Modeling the influence of the shadow sector of the economy on the need for cash // Scientific and technical statements of St. Petersburg State Polytechnical University - St. Petersburg, 2011. - No. 1. - S.260.

unemployment, and the presence of small size of production in shady economics results in distortion of these facts. It includes facts about activities of shady economics in official statistics of national accounts. Persons, engaging in elaboration and conducting politics, and collaborators of state bodies for making decisions about distributing resources must acquire information about number of persons engaging in shady economics, rapidness of conducting and the scale of this activity.

However, to estimate the scales of shady economics is rather difficult. In certain account, people, engaging in half activities, strive all attempts not to discover. A number of investigations show that tax regime seems to have a great influence to widening the shady economics. In Austria, loading straight taxes (including payments on social securities), have more influence to the growth of shady economics; the next by the level of influence, is the number of normative acts, concerning companies and workers, and also the difficulty of tax systems. This situation can be observed in Scandinavian countries, Germany, and the USA. Measures of state regulating, these such as demanding on license, trade barriers, normative markets of labour and others, can increase the cost of working force for companies in official economics. Employers in official economics, putting main part of additional expenses, connected to these measures of regulating on their workers actively are urging them to pass to shady economics, where can be avoided of these expenses.

State bodies must engage in improving the observance of laws and regulative acts, instead of engaging in increase their quantities. Shady economics, as a rule, have small sizes in countries where strong and effective institutes of state management work. High level of regulating economics with weak and discretionary use of laws creates favorable land for shady economics.

As the operation of shady economics is usually conducted in exact form, increase of activeness in this sphere, as a rule, brings to extending of demand for cash and, in turn, to widening external monetary circulation. As a result, monetary bodies will be in difficulty to estimate consumes of economic subjects by cash. At present, the fact is that in the republic more than 60% of money mass consist of cash devices, gives opportunity to suppose about exist of vast number of cash operations of shady business, which in no where is taken into account and don't transfer by bank channels.

Table 1

Specific cash in the structure of the monetary aggregate M2

	2016 y.	2017 y.	2018 y.
Japan	7,3	7,3	7,2
Australia	5,3	5,4	5,3
Russian	20,1	19,9	9,8
Uzbekistan	25,2	26,6	27,6

The data presented show that in 2016-2018 in Japan Australia, the specific total cash in the M2 structure was low and stable.

In 2016-2018, in Russia and Uzbekistan, the specific total cash in the M2 structure was high. This is due to the presence of non-banking cash turnover and the underdevelopment of non-cash payments.

To our mind, it is necessary to take these measures, capable to decrease external circulation of cash:

1. Dismissal of commercial banks control functions and denying interference to their operational procedures (refusing to conduct the registration of debtor's and creditor's debts of clients; cancellation of practices performing charges of tax and other inspectorate organs; not to place on commercial banks carrying on forecast indexes by entering cash devices, which also decrease access of bank clients to cash devices and confuse timely conducting their monetary transactions).

2. To provide the liquidity of commercial banks, timely carrying on demands of clients, connected to the access to cash and money transfers.

3. To provide full observation of principles of bank secrets, this provides banks with any information about their clients on exact legislative conditions.

4. Gradually to equalize the heaviness of tax payments for different categories of tax payers, to decrease groundless individual privileges, to strengthen tax laws more than transparency. To provide neutrality of taxes according to inflation, organizational law forms, connected to basic and circulative devices, the period of production circles, to improve co-operation of tax administrations and tax payers. Those who at present pays taxes in time, must observe facilitation of tax press.

5. To decrease tax obligations to fund of salary payments, to decrease the rate of single social tax of enterprises. These measures permit to decrease cost price of production and decrease prices, and also increase s the volume of investments at the expense of private sources.

Bibliography:

1. Decree of the President of the Republic of Uzbekistan dated November 29, 2017 "On the establishment of the Ministry of Innovative Development of the Republic of Uzbekistan" // Collection of Legislation of the Republic of Uzbekistan, December 4, 2017, No. 48, Article 1179

2. Amanov O.A. The Importance Of Digital Technologies In Ensuring Employment [Электронный ресурс] // Экономика и социум.-2020. - № 12 (79) (дата публикации:14.12.2020).-URL: https://a78cf8ac-3ef5-4670-8fcd-a900ec94fdfb.filesusr.com/ugd/b06fdc_274dd51640744059aa540e946f304bdf.pdf?index=true (дата обращения: 16.12.2020)

3. Amanov O.A. The main directions of modernization of the rural labor market. Monograph. - Tashkent: "Science and technology", 2014. P.77.

4. Narmamatov Ixtiyar Baxtiyarovich (2020) "Development of Non-Cash Payments: Problems and the Ways to Solve Them", International Journal of

Advanced Science and Technology, 29(9s), pp. 4193 - 4195. Available at: <http://sersc.org/journals/index.php/IJAST/article/view/16787> (Accessed: 19 December2020).

5. Amanov O.A. Ways of regulation, condition and employment trends of the population of the republic of Uzbekistan. Journal of Management Value & Ethics. India. ISSN: 2249-9512 Vol 8, №2, 2018.–P.98-106. URL: https://www.jmveindia.com/journal/APRIL-JUNE_18.pdf

Nosirova M.K.
Senior teacher of department of foreign languages
faculty of agro engineering and hydro melioration
Andijan Institute of Agriculture and Agro technologies
Uzbekistan, Andijan

PRACTICAL USE OF TEACHING METHODS FOR TEACHING GERMAN IN THE LESSON

Abstract: When teaching German as a second language after English, you must rely on the general principles that apply when teaching any foreign language. Despite the fact that these principles have much in common, they still have some modification in relation to the second foreign language, taking into account the specificity of the learning conditions, for example, the presence of three languages in contact during the learning process, extensive experience in learning a foreign language, etc.

Key words: second language, German, principles, learning process, speech activity, communication, material, method, training, competence.

The article highlights the reasons that affect the negative attitude of students to a foreign language, these include:

1) Lack of systematic and in-depth clarifications about the importance of learning foreign languages;

2) Incorrect teaching, which does not stimulate logical and meaningful memorization of language material, but orientates students only to intuitive understanding. Students accustomed to a system of work based on the principle of conscious learning cannot come to terms with a method of working on a language that contradicts their usual focus in working on other subjects. As a result, they become convinced that a foreign language is some kind of special subject that requires primitive, uninteresting forms of work;

3) Inability of the teacher to organize work depending on the different levels of education. The methodology of teaching a foreign language should be rebuilt at different stages of work, of course, in accordance with the age characteristics and the increased volume of students' knowledge.

4) Lack of tangible practical results of work on the language among students. Students, after several years of studying a foreign language, not seeing the practical results of this study, are disappointed and come to the conclusion that their work on the language is useless, which, of course, does not contribute to an increase in interest in the subject being studied.

5) Lack of timely individual assistance in the event of a backlog of students.
The most essential principles are as follows:

1. As in teaching any foreign language, communicative goals predetermine the general methodological approach to teaching. But since the students already have experience in learning English, mastering German is carried out by them more consciously, they can compare both certain linguistic phenomena of English and German, and the organization of the learning process. Pupils studying English and German have more developed reflection (looking at themselves from the outside, the desire to give themselves an account). That is why the general methodological principle in teaching German can be defined as communicative-cognitive, where the cognitive aspect is subordinate to the communicative one, and it manifests itself where it is necessary to find any analogies that facilitate assimilation, or, conversely, to identify differences in order to avoid interference.

2. The entire educational process should be focused on the student's personality, on his development, independence, on taking into account his capabilities, needs, interests.

When teaching German, there are even more prerequisites for this than when teaching English, thanks to the experience of learning a foreign language, a later start of education (from the seventh grade of a school with an in-depth study of English) and, thus, a more conscious approach to learning the language.... For some students, it is necessary to create conditions for faster progress, while others should be given the opportunity for repetition and training.²¹

A German lesson is a logically completed part of the work of teaching a language, the main goal of which is to achieve certain goals of a practical, general educational and educational nature. To achieve a positive result in the implementation of these goals, it is necessary to do pre-planned exercises and tasks, based on the means and teaching methods laid out by the teacher. The essence of the lesson depends on the speech orientation.

A German lesson can only be complex, that is, it should contain a variety of types of work and study different aspects of the language. During the lesson, students should demonstrate vigorous speech activity.

Learning German will be faster and easier if:

- rely on similarities with English, as well as find support in the native language;
- use a linguistic guess (about the meaning of a word, grammatical form), relying on the context, on the familiar parts of the word;
- notice differences in linguistic phenomena and ways of expressing thoughts;
- transfer to a new language the ability to work (find the meaning of a word in a dictionary, use a paraphrase, perform various exercises, etc.).

²¹ N.A. Odilova. Foreign language communicative competence and its features of formation in a non-linguistic university. International scientific journal. Economy and society. № 6(73) -s.: 2020.

Nowadays, active learning is reproached for the lack of a clear theoretical concept, for mixing different approaches and methods under one name (in particular, there is no generally accepted classification of methods).²²

Language games are designed to form lexical skills and train the use of language phenomena at the preparatory, pre-communicative stage of mastering a foreign language. The game is currently considered one of the most effective methods of teaching a foreign language. They contribute to the creation of a verbal communication environment in the lesson, arouses interest in learning a foreign language.

It is important to note one more important circumstance. Practicing teachers, using active learning methods, note the presence of certain barriers that prevent their use. In the article by C.C. Bonwell and T.E. Sutherland, "Continuity of active learning: the choice of activities to enhance student learning in the classroom", the following barriers are identified when using active learning methods:

- difficulty in presenting a large amount of material in the classroom.
- active learning takes too much time to prepare the lesson;
- the impossibility of using active teaching methods in a large audience;
- the possibility of negative consequences: the attitude of colleagues to new approaches; the impact of student assessment on teacher performance; influence on promotion.

There is another barrier - this is the resistance of students to new approaches and methods. Moreover, the more experience of educational activities of students, the more resistance can be met in the classroom.

The educational process is the most difficult moral relationship between a teacher and a student, in which the corresponding, defining feature is the upbringing of a sense of honor and dignity. The task of each teacher is to skillfully and sensitively, persistently and demandingly educate the mental and moral strength of the child, help him to comprehend learning as work that requires a lot of stress, and is joy only when the child overcomes difficulties on his own and achieves success. ... Not to force a child to study, but to arouse interest in acquiring knowledge - this is the task of every teacher.

Literatures:

1. N.A. Odilova. Foreign language communicative competence and its features of formation in a non-linguistic university. International scientific journal. Economy and society. № 6(73) -s.: 2020.
2. Irgashev M.U. Modern pedagogical technologies as a resource of the modern lesson, ensuring the development of educational standards. International scientific journal. Economy and society. № 6(73) -s.: 2020.

²² Irgashev M.U. Modern pedagogical technologies as a resource of the modern lesson, ensuring the development of educational standards. International scientific journal. Economy and society. № 6(73) -s.: 2020.

3. N.A. Odilova., M.U. Irgashev. Information and communication technology in language learning. International conference., 2016, p.439.
4. G.T. Qodirova. Linguistic and communicative competence in learning language. International conference., 2016, p.441.
5. Mets, N. A. the Linguistic basis of describing the Russian language in order to teach it as a foreign language / N. A. Mets. - Moscow, GIRYAP, 2003.

*Nuritdinova Yo.A.
teacher of department of foreign languages
faculty of agro engineering and hydro melioration
Andijan Institute of Agriculture and Agro technologies
Uzbekistan, Andijan*

THEORETICAL FOUNDATIONS FOR THE IMPLEMENTATION OF THE PROBLEMATIC APPROACH IN TEACHING FOREIGN LANGUAGES AT SCHOOL

Annotation: The relevance of the work is substantiated both by the need of pedagogical science in the theoretical development of issues of implementation of teaching students to communicate in their native and foreign languages, and by the need of domestic higher education for new approaches and methods aimed at the formation of an active creative personality who can find a solution to a problem in problem situations, which is facilitated by problem learning.

Key words: teaching, competence, approach, education, problem, learning, foreign languages, method.

Problem-based learning is a type of developmental learning, which combines the systematic independent search activity of students with their assimilation of ready-made conclusions of science, and the system of methods is built taking into account goal-setting and the principle of problematicity, the process of interaction between teaching and learning is focused on the formation of students' cognitive independence, stable motives to learning and thinking abilities in the course of their assimilation of scientific concepts and methods of activity, determined by the system of problem situations.

Problem-based learning currently has several varieties, depending on which goal is singled out by the teacher as the main one. So, this can be the assimilation of knowledge, skills and abilities by students, then the teacher guides and directs the process of resolving problem situations, and by increasing the independence and personalization of the knowledge gained, they are more assimilated by students than with explanatory-illustrative and reproductive methods, and the educational process is activated due to the greater interest from the students - problem-based learning turns into an improvement in teaching methods and the structure of educational material.

Problem-based learning can be close to developmental learning, if its task is to develop the intelligence of students - by increasing the independence of students when resolving problem situations, active cognitive activity is formed, freedom in the use of methods of mental action is achieved.²³

²³ Majidova Z.A. The cognitive aspect of using phraseological units in teaching translation. International scientific journal. Economy and society. № 6(73) -s.: 2020.

In theory, all these goals are recognized in problem learning, but in practice, the teacher independently builds one or another hierarchy when structuring educational material, developing a methodology and implementing the educational process.

With the help of problem-based learning in FL lessons, you can:

- To reveal the individual inclinations of each student;
- To teach to observe, to research, to activate mental activity, because there are no ready-made answers to questions in any textbook;
- Teach to listen and hear each other, to respect the opinion of the interlocutor;
- To interest students in the knowledge of the surrounding world;

In teaching foreign languages, problem learning is the predominant use of the research reflex of self-development in the educational process due to such a way of teaching as search. Reliance on the research reflex increases the motivation for learning a foreign language. That is why it is necessary to widely use the techniques of problem-based learning to achieve success in educational activities. Problem-based learning offers the following techniques to the foreign language teacher:

- Problematic presentation - the introduction of new material, in the process of which a teacher or a textbook shows the way to solve a problem;
- Problem heuristic conversation - a series of interrelated questions from the teacher or questions contained in the textbook to students.

In each such question there is a problem, without solving which it is impossible to proceed to the next stage of search activity. A series of interconnected problematic questions leads to the assimilation of the material of the next lesson.

Problematic tasks-tasks can be performed if the goal to be achieved, the subject of the action to be manipulated, and finally, the mode of action, i.e. how to solve it.²⁴

Problematic questions - suggest the presence of some knowledge from the material covered. Thus, problematic questions can be excellent for organizing control and verification.

Problematic remarks are used to switch students' attention to the content of their speech.

Problem situations are situations that induce speech actions. Driving factors can be:

- 1) tasks;
- 2) standard situations;
- 3) prompting remarks.

²⁴ Usmonova Sh. Study of scientific technical transfusion in non-linguistic educational university. International journal. Questions of science and education/ Moscow.2019. p. 105.

In pedagogical theory, it is believed that the productive cognitive activity of a student in a problem situation and, accordingly, the process of problem learning can be reduced to the following main characteristic stages.

- the emergence (formulation) of a problem situation;
- awareness of the essence of the difficulty (contradiction) and problem statement (formulation of the problematic task);
- finding a way to solve a problematic task by iterating guesses, hypotheses, etc. with an attempt at appropriate justification;
- proof of the hypothesis;
- checking the correctness of the problem solution.

Along with the problem situation, scientists also single out a problem question (or task) as an important concept of the problem approach in teaching. A problem task is characterized by a contradiction between the available knowledge and known methods of action, on the one hand, and the requirements of the tasks, on the other. Therefore, his decision is associated with the search for new ways of acting. In conclusion, it should be noted that problem learning stimulates the personal activity of students, which ensures an active attitude to knowledge, systematic and persistent students, and, of course, a positive result in teaching foreign languages.

Students become more sociable, know how to substantiate their point of view, find their own way of expressing thoughts and feelings. Self-control is shown when performing practical tasks. The behavior of students in the team changes: they behave more actively, listen to each other, defend their point of view. Problematic teaching in school practice appeared due to the research search for creatively working teachers who are not satisfied with the dullness and monotony of traditional combined lessons. And the specificity of teaching foreign languages is such that the development of new knowledge, unfamiliar layers of culture is more active in the conditions of resolving the contradiction between what the child already knows and what he has to master. A modern specialist needs to be aware of the development of his field in world practice.

The maximum development of communication skills is the main, promising, but very difficult task facing teachers and teachers of the English language.

To solve it, it is necessary, on the one hand, to master new teaching methods aimed at the development of all four types of speech activity, the formation of linguistic, sociolinguistic and pragmatic competences, and on the other hand, to create fundamentally new educational materials with which you can teach people to communicate effectively in English language.

At the same time, of course, it would be wrong to rush from one extreme to the other and abandon all the old methods of learning English: from them all the best, useful, time-tested ones must be carefully selected.

Its effectiveness, in addition to knowledge of the English language, depends on many factors: conditions, situations and culture of communication, the rules of

speech etiquette, speech behavior, knowledge of non-verbal forms of expression (facial expressions, gestures), the presence of deep background knowledge and much more [5, 93-97].

Working with information in English requires the formation of certain intellectual skills: the ability to analyze information, select the necessary facts, building them in a logical sequence, the ability to put forward arguments and counterarguments.

Therefore, the process of teaching English can be effectively updated by problematizing the educational process using information sources.

Teaching a foreign language in today's rapidly changing conditions involves the use of methods of activating and problematizing language education.

The problem in teaching English is manifested, as in the selection of information support for the educational process.

A problematic approach to teaching English can be carried out for all types of speech activity (speaking, reading, writing). At each stage, a system of exercises can be used based on the problem situation. When performing these exercises, visual and auditory visualization plays a huge role, which allows you to diversify the options for problem situations. To create a learning situation, you need to know the components that make up its semantic content. The components of the semantic content of the situation include the following: purpose, participants, place and time of communication.

References:

1. Majidova Z.A. The cognitive aspect of using phraseological units in teaching translation. International scientific journal. Economy and society. № 6(73) -s.: 2020.
2. Usmonova Sh. Study of scientific technical transfusion in non-linguistic educational university. International journal. Questions of science and education/ Moscow.2019. p. 105.
3. Matkarimova G. Formation of the English scientific competence in students of non-factual faculties. International journal. Moscow.2019.
4. Egamberdiyeva D.U. The essence of the method of video-English. Conference materials. 2016.
5. Majidova Z.A. Innovative methods and approaches in learning and teaching foreign language in foreign methodology. Moscow. 2019.
6. G.T. Qodirova. Linguistic and communicative competence in learning language. International conference., 2016, p.441.
7. N.A. Odilova., M.U. Irgashev. Information and communication technology in language learning. International conference., 2016, p.439.

Ochilova M.Sh.
Senior teacher of literature in the native language
of NDKI academic lyceum

ALISHER NAVOI'S MYSTICAL VIEWS ON THE RELATIONSHIP BETWEEN THE UNIVERSE AND MAN (ON THE EXAMPLE OF "SAB'AYI SAYYAR")

Annotation: This article deals with the philosophical analysis of the universe, the creation of being, man and the events related to it in the epic "Sabayi Sayyar", which is part of the epic "Khamasa".

Keywords: mysticism, being, idea, thinker, enlightenment.

The classical heritage, which has become an invaluable addition to the treasury of world literature, has nurtured generations for centuries and will continue to do so. Alisher Navoi created immortal works and created a great philosophical school in the history of culture of the peoples of Central Asia with his philosophical-aesthetic, enlightenment views and ideas. The great thinker and humanist, from his predecessors Ahmad Yassavi, Sakkoki, Khorezmi, Lutfi, and other contemporary artists, speaks with respect and respect for the history of philosophy and the philosophy of that time. wrote a number of works reflecting the processes and left a good name for himself as a literary critic, philosopher-literary critic. The praise chapter of the epic "Sab'ai Sayyar", which is part of the epic "Khamasa", contains the following:

Yo`q edi odamiki bor etting,
 Kishilik birla e`tibor etting.
 Yo`q ham etsang ani-o`q etgungdur,
 Bor qilgungduru yo`q etgungdur.²⁵ [1.277]

That is, you created a person who did not exist and paid attention to the person. It is up to you to create it and to destroy it. The mind of the slave is weak in these works of truth. Indeed, man does not know what it is to make non-existence exist and to destroy existence. He is helpless, amazed only at what Allah has created.

The poet Erkin Vahidov once said: "Alisher Navoi's poems contain not only beautiful allusions and deep philosophical thoughts, but also magic and celestial melodies that amaze the mind."²⁶ We can observe this situation in the above verses as well. The epic depicts the artistic expression of the state of love, in which the love trade destroys the whole body.

Ishq sensen dog`iyu oshiqsen,

²⁵ Alisher Navoi "Complete collection of works", 10 volumes, 7 volumes. -Tashkent, page 277. In the following pages, where the same source is used, the page number is placed in the quotation itself.

²⁶ Erkin Vohidov. Shoiru she`ru shuur. - Tashkent, 1987. p.47.

Yana ma`shuqluqqa loyiqsen.
Ayni ma`shuqluqda jilvai zot,
O`zini ko`rgali tilab mir`ot [1.279]

Love is you and you are in love. You deserve to be loved. Beautiful person wants a mirror to see himself in love.

On the philosophical basis of the mystical worldview, God is not a cause that exists outside the world, but is considered an inseparable unity with the universe.

Sensenu sendin o`zga xud nima yo`q,
Gar ko`runsa sen o`lg`ung ul nima-o`q.
Hech nima yo`q sen eding mavjud,
Ham sen ulg`ung bori bo`lub nobud.[1.280]

If you go, there is nothing but you, even if it is visible, you are in it. There was nothing, you existed. You are alive, and the rest are doomed.

According to Hazrat Navoi, all the worlds of sophistication in the world are aimed at serving people, and all the subtleties and facets of this sophistication are reflected in the beauty of God. He embodies in his philosophical views the fact that his spiritual image and moral qualities are determined by how much he benefits the people.

Ey ko`ngil, boqmag`il jahon ishiga
Kim, jahonn qilmadi vafo kishiga.
Bu ulug`roq kesak erur bu jahon
Ki, erur ko`pragi suv ichra nihon.[1.613]

O soul, do not act according to the affairs of the world, for no one has fulfilled it yet. This world is a huge chunk, most of which is hidden in the water.

When a person is deceived by the blessings of the world, he goes down into the abyss. Everything in the world is temporary. The lump cannot stand in water, it is likely to melt for a while. Human life is as extinct as a water-soluble shell.

The character of Navoi Bahrom is changed by the details of the events that are part of the main stereotype. When the king was drunk and he was not aware of what was being done, he explained by examples that calamities would befall the people. At the end of the epic, the main philosophical idea is stated. Saidbek Hasanov says: "He notes that human life is short and fleeting, and that it should be spent only for good. This idea is the main ideological direction of Navoi's epic.²⁷For this reason, although love is embodied in events as a central concept, the main idea is focused on human perfection. In the example of the image of Dilorom in the epic we can see a progressive approach to the problem of women.

In conclusion, the study of the world and man in the great thinker Alisher Navoi's "Sabai Sayyar" is a way to open the horizons of the study of creative philosophical views, as well as the impetus for positive changes in our modern social situation.

²⁷ Saidbek Hasanov "Seven Gifts of Navoi" p.131

References:

1. Alisher Navoi "Complete collection of works", 10 volumes, 7 volumes. - Tashkent, page 277.
2. Erkin Vohidov. Shoiru she'ru shuur. - Tashkent, 1987. p.47.
3. Saidbek Hasanov "Seven Gifts of Navoi" p.131

*Ochilova N.S.
teacher of the department of interfaculty foreign languages
faculty of foreign languages
Andijan State University
Uzbekistan, Andijan*

ORGANIZATION OF THE EDUCATIONAL PROCESS USING DISTANCE LEARNING

Abstract: Distance education seems to be especially important for English with its vast territory, uneven population density and the location of university centers. However, the use of DL in practice without appropriate methodological training can lead to discrediting of DL as a form of education. Lack of a unified concept, lack of practical experience often lead to completely opposite views on this form of education: from reduction to a set of means and methods of transferring educational information to its absolutization, to the appearance of ideas about creating a virtual educational institution, etc.

Key words: distance learning, educational processes, practical, methods, virtual, organization.

In modern conditions, there is a growing need for the formation of a flexible distributed system of lifelong education, with the help of which a person is provided with access to world information resources and databases and the opportunity to continuously improve his professional skills throughout his life. Such a system allows a person to be professionally mobile and creatively active. This opportunity is provided by distance education, which is one of the most actively developing areas.

The process of organizing distance learning among students of various educational institutions.

The modern orientation of higher education towards the formation of competencies as the readiness and ability of the future professional to work and communicate involves the creation of didactic and psychological conditions in which a participant in the educational process can show not only intellectual and cognitive activity, but also a personal social position, his individuality, which allows him to express yourself as a subject of learning. In this regard, distance learning as a special form of organizing cognitive activity, focused on increasing the efficiency of the educational process, achieving high results, is of particular importance in the professional training of future specialists; strengthening of cognitive motivation, formation and development of general cultural and professional competences of future specialists.

In pedagogical practice with traditional forms of education, well-known forms of education have developed. When teaching social and humanitarian

disciplines, the most common received: lectures, seminars, laboratory classes, tests, term papers, exams, independent work, etc. All of them take place with certain specifics in the LMS both in the contact and non-contact periods of training.

At present, methodologists believe that pronunciation training should be conducted throughout the entire period of language learning, although the role of this work and its nature should change at different stages of training.²⁸

1. The goals of distance education can be formulated as follows:
 - introduction of the latest educational technologies into the learning process and the creation of a modern educational space through this;
 - stimulation of independent search work of students, guided by teachers;
 - a gradual transition from reproductive education to a more modern creative.

To achieve these goals, distance learning initially must solve a number of fundamental problems. In a rather general form, they can be formulated as follows.

In the distance learning mode, knowledge certification is carried out by sending the student electronic control tests and measurement materials. Previously, the problem was to establish the reliability that the task was completed by the student himself, without the help of other people. Now this problem has been solved with the help of new communication tools (such as Skype, an Internet telephony program with video calling and video conferencing capabilities). Thanks to them, knowledge control can be carried out in real time, including in the process of communication between the teacher and the student "face to face."

Control in the educational process consists in checking the course and results of the theoretical and practical assimilation of the educational material by the students. Assessment of knowledge, skills and abilities acquired in the course of distance learning is of particular importance due to the lack of direct contact between the student and the teacher. The role and importance of objective and multi-criteria forms of knowledge quality control is increasing. A feature of control in the LMS is the need for additional implementation of the functions of identifying the student's personality to exclude the possibility of falsification of training.

Organization of feedback from the student. This is important for the timely adjustment of the educational process by the teacher [3]. Learning management is one of the most challenging tasks in distance learning. It includes the synchronization of all educational activities, recruiting groups of students, dosing the load between teachers, issuing various certificates and other organizational activities. This task is feasible with the help of modern technologies.

²⁸ Matkarimova G. Pronunciation training is based on methodological principles. International scientific journal. Economy and society. № 6(73) -s.: 2020.

A significant expansion of the functionality of Moodle is achieved through the integration of a subsystem for organizing webinars / web conferences. In addition to language support and design templates, Moodle also allows you to connect the following types of modules:

- 1) course elements;
- 2) administrator reports;
- 3) types of tasks;
- 4) authentication plugins;
- 4) blocks;
- 5) course formats;
- 6) reports on courses;
- 7) database fields (for the course element "Database");
- 8) course subscription plugins;
- 9) filters;
- 10) assessment reports

The special role of distance learning in the formation of professional skills and abilities of future specialists is emphasized in the Federal State Educational Standard for Professional Education of the Third Generation.

Thus, the increasing demands of society and employers for a modern professional, a change in the tasks of vocational training associated with the implementation of a competency-based approach, raise the question of the need to study the educational potential, theoretical foundations and methodological support of distance learning in the process of professional training of a modern professional.²⁹

Currently, DL is widely used traditional regulated forms of education: lectures, seminars, consultation examinations, independent work, etc. The specificity of the use of these forms in DL is manifested in the frequency of their use in the educational process and the predominant use of new information technologies[3]. Information-receptive and reproductive teaching methods are currently most often used in English DL practice, and among the teaching aids - printed, computer and audio-video materials. Printed training materials for the discipline for preschool education should contain at least: recommendations for independent study, the main text, control tasks, training tasks, an explanatory dictionary of terms. In general, training according to the manual should provide the trainee with a minimum of access to additional literature. The pedagogical potential of interactive learning in the system of professional training of a teacher, which consists in the possibility of activating the subject experience of the future teacher and including it in active cognitive and communicative activities to solve educational and professional problems, requires further study.

²⁹ Matkarimova G. The use of the phonetic exercises to develop of speech skills in English lessons. International scientific journal. Economy and society. № 6(73) -s.: 2020.

Distance education is defined as education that is fully or partially carried out with the help of computers and telecommunication technologies and means. The subject of distance education is removed from the teacher and / or teaching aids and / or educational resources. The interaction of the teacher and students with each other occurs at a distance, without losing the components of the educational process and is implemented through Internet technologies. Based on this, distance education, first of all, implies a high development of information and communication tools.

List of references:

1. Matkarimova G. Pronunciation training is based on methodological principles. International scientific journal. Economy and society. № 6(73) -s.: 2020.
2. Matkarimova G. The use of the phonetic exercises to develop of speech skills in english lessons. International scientific journal. Economy and society. № 6(73) -s.: 2020.
3. Usmonova Sh. Study of scientific technical transfusion in non-linguistic educational university. International journal. Moscow.2019.

*Odilova N.A.
teacher of department of foreign languages
faculty of agro engineering and hydro melioration
Andijan Institute of Agriculture and Agro technologies
Uzbekistan, Andijan*

USE OF INNOVATIVE METHODS IN PROFESSIONAL DISCOURSE OF A TEACHER OF FOREIGN LANGUAGES

Abstract: The article is devoted to the problem of using innovative methods and different active forms at foreign language lessons at school. In article various active methods are considered, but the most effective method in our opinion is the method of organizational-training game which promotes intensive training of memory, development of creative imagination and communicative skills of learners. The given innovative methods promote development of informative activity of students that in turn is defining stimulus, motivation and interest to studying a foreign language.

Keywords: education, students, process, educational complex, innovative methods, linguistic games, organizational-training game, communicative skills, modernization of the education, knowledge.

Now in modern didactics there is a burning search of effective paths to develop students' informative forces and abilities. During an epoch of rapid development of industrial forces, scientific and technical progress, volume of the arriving information, life puts in the forefront in school training a problem of activation of informative (cognitive) activity of learners. The maximum development of the creative approach to any activity, development of the initiative, activity and independence in all members of a society is the requirement of today's life. The beginning of formation of these qualities should be necessary at school. Informative activity of learners at school is a necessary stage of preparation of young generations to life and work. The primary goal of any teacher is to search and find new methods and means of perfection of a lesson which would lead to activation of informative activity of learners. Doctrine activation can be presented as a line of activity of learners on the decision of problems with use of the most various sources of knowledge [1, 48].

Informative activity is effective force of formation of the person of the pupil in educational process as it promotes occurrence of the intellectual response to process of knowledge and provides cognitive-emotional responsiveness of the learners in informative process. At the present stage of development of a society the foreign language for many people is a vocational training component. However, despite presence of enormous requirement for mastering by learners by foreign languages, the contradiction between the purpose of training to a foreign

language at school and real results is observed; On termination of obligatory employment at school many never more are reverted to language studying; knowledge degree is reduced only to primitive level; the foreign language at comprehensive school for many is the poor progress factor. One of paths of the decision of this problem is an application of such means, forms and the training methods which introduction essentially variants lesson frame, the form of activity of learners and learning, raises efficacy of teaching and educational process [4, 55].

Modernization of the maintenance of formation at the present stage of development of a society is not in the last instance connected to innovative processes in the organization of training to foreign languages.

The main task of modern training not only to yield wide formation, but also to arrange the person of the growing up person to independent acquisition of knowledge, to constant tendency to go deep into knowledge area, to form proof informative motives of the doctrine, informative interest is basic of which. For formation of informative interest of learners there are variety of factors, including search of methods and forms of the organization of educational activity matters. Does not raise the doubts that fact that the problem of the teacher consists in finding and development of such forms of work which would aggregate the teacher and learners in one creative collective e, would raise a role of independent work, activity of learners in all process of study.

From this point of view the major problem of school – formation of high-grade citizens of the country. And on decisions of this problem in many respects depends, than the schoolboys will be engaged, what trade will select, and where will work. The school cannot yield the person a store of knowledge on all life. But it in a state to yield the schoolboy the basic basic reference points of the basic knowledge. The school can and should educe informative interests and abilities of the learners, to impart to it the key competences necessary for the further self-education.

Today in the attention center – the learners, its person, unique private world. Therefore the main objective of the modern teacher – to choose methods and forms of the organization of educational activity of learner which optimum correspond to an object in view of development of the person.

Last years the question on application of new information technology at high school is even more often brought up. It not only new means, but also new forms and the teaching methods, the new approach to training process. A main objective of training to foreign languages is formation and development of communicative culture of pupils, training to practical mastering by a foreign language.

As has shown the analysis of the scientifically-methodical literature on the yielded problem that the problem of the teacher consists not only in creating conditions of practical mastering by tongue for each learners, to choose such methods of training which would allow each learners to display the activity, the

creativity, but also to stir up informative activity of the learners in the course of training to foreign languages. In our opinion, such modern pedagogical technologies as training in cooperation, the design procedure, use of new information technology, Internet resources help to realize the personal-oriented approach in training, provide an individualization and differentiation of training taking into account abilities of children, their level of education.

We consider that the most successful variant at the decision of the problems set forth above is the effective utilization of innovative methods and training receptions at foreign language lessons at school in the form of organizational-training game.

It is known that games on a foreign language it is the special kind of the didactic stuff used for the purpose of increase of informative interests of learners, but language game, as a rule, contains not only the entertaining information. Comprehension new knowledge and abilities “is disguised” in the form of game that promotes intensive training of memory, development of creative imagination, strengthening of skills of dialogue. Submergence on language medium and application of game technologies allows mastering great volume linguistic information for rather short time.

As the primary goal of a language subject is formation of basic communicative abilities on the foreground questions of research of motivation and efficacy of game act. Game – voluntary business to force to play it is impossible, game it is possible to carry away only children the criteria and assessments, the preferences. How to make so that the offered game has cleared in children interest to learn a foreign language and the activity gradually passing from game to the educational?

Own understanding of the yielded problem it is visible in the following. Game, as well as other forms of activity should be under construction on certain principles. Accordingly the knowledge of the main rules of the organization of game activity will predetermine its success. Taking into account the told we will evolve some the basic requirements shown to carrying out of linguistic games which we try to adhere in the work:

1. Intriguing and entertaining purposes;
2. Availability of game to all children;
3. Aesthetic appeal of game;
4. The right of participants of game to an error and a freedom in choosing of actions;
5. Competitive character of game.

The purposes put in the name of linguistic game, should be opened and at the same time intriguing. In the instruction to game on the foreground it is necessary to put forward allure and singularity of forthcoming actions, appeal of a net result. Provocation, i.e. artificial excitation of interest, considerably raises motivation to game, promotes emotional enthusiasm. Such approach will allow

on the offer: we Will play in words? – hear in the answer the joyful consent: we Will play!.

Linguistic games should be accessible to all children have worked an indispensable condition – participation of all and everyone. Linguistic games should be “beautiful” and draw attention of potential participants not only the maintenance, but also the form. It is a question of the thought over design of a requisite (the table with texts of proverbs, tongue twisters; bright posters with the plotting of plants etc.; schemas – models for construction of offers; a map, etc.) and an interior (tour agency, cafe, shop etc.). For this purpose skillfully enough to dispose of a board, paints and to involve extra linguistic stock (a barrel – a whirly, clothes elements, accessories, flowers, foods etc.). The kind of the premise decorated with attributes, according to a game situation, softens an emotional pressure and helps participants to be adjusted on game.³⁰

The game purpose: to dilate a linguistic and cultural urological outlook of learners, to make active a regional geographic stuff (names of the countries English-speaking).

Game conditions: children sit down in a circle. The first says the name of the English-speaking country, the second retries the first name and adds the.

Game conditions: the leader suggests competing commands in a definite time «to collect a bouquet» English primroses, having chosen their names from the presented list of words.

The positive emotions invoked by game, the dialogue inherent in organizational-training games, in a complex with suggestive delivering of stuff form the informative interests of learner promoting informative and communicative activity of learners, to involuntary mastering of the information speaking another language.

It is possible to assert that all modern innovative technologies are directed on increase of activity of learners: the true got by inherent stress of efforts, has huge informative value. The activation of educative-informative activity lifted on level of creative processes, more all expresses reformative character of activity. Its creative character is always connected with something new, to change of a stereotype of actions, activity conditions. The main thing – satisfaction activity that congenially influences both motives, and on doctrine means, and on adaptability of learners to dialogue with the teacher, with schoolmates, on building of the congenial attitudes in activity.³¹

Thus, it is possible to ascertain that purposeful and regular use presented above technologies at training to a foreign language promotes realization of following purposes such as, to perfection of abilities of learners in oral and written speech, to dilating of an outlook of trainees, development of communicative

³⁰ X. Alimova. The importance of exercises in the comprehensive training in all types of speech activity. № 6(73) -s.: 2020.

³¹ Muxitdinova F.R., Hudayarova O.Z. Structural and content Characteristics of texts and increasing the various types of oral work. Научный электронный журнал “Вопросы науки и образования”. 2019. p. 116.

skills, abilities to work with the dictionary and other sources, stimulates schoolboys to be active, educates at them interest, imagination.

List of references:

1. X. Alimova. The importance of exercises in the comprehensive training in all types of speech activity. № 6(73) -s.: 2020.
2. Muxitdinova F.R., Hudayarova O.Z. Structural and content Characteristics of texts and increasing the various types of oral work. Научный электронный журнал “Вопросы науки и образования”. 2019. p. 116.
3. Ахмаджонова Sh.N. Developing speaking aspect of students. Научный электронный журнал. 2019., p. 211.
4. Irgashev M.U. About the problem of motivation of educational activity of students in the conditions of education in the university. Moscow: 2019.

MOTIVATIONAL IMPACTS FOR EFFECTIVE VIRTUAL TEACHING AND LEARNING

Abstract: The article introduces motivational impacts for effective online education process that deal with losing interest, satisfaction and motivation among learners during global critical period. By looking broadly motivational constructs, the impacts of sources, interaction, digital tools and course projects as a process of motivating developments.

Keywords: Motivational impacts, motivational constructs, motivation sources, online interaction, digital tools, online activities and projects.

Fresh ingredient make the food tasty and enjoyable and it serves for human health and development. If the process of preparing food is done by updated technology and tools, it will be handfull and economize the time. In this way, we may compare the impact of say with effective virtual teaching and learning. Today's world is involving learners and young generations to be driving force of virtual atmosphere. One of the major problems among virtual teachers comment on is lack of student motivation. By defining Longman Dictionary of Contemporary English, Motivation refers eagerness and willingness to do something without needing to be told or forced to do. It refers that without sufficient stimulant, young minds even with distinctive talents are not able to accomplish objectives. Motivation is the "engine" of learning.(Paris& Turner,1994) Motivation can influence what we learn, how we learn, and when we choose to learn(Schunk &Usher,2012) Compared to classroom learning environment more and more students are losing interest and motivation by running virtual lessons. Studies show that explore motivation to learn in online contexts are limited in both numbers and scope . Studies used task choice, cognitive effort, persistence, skill, and achievement to measure motivation. (Bekele,2010). Feelings of isolation (Paulus & Scherff, 2008), frustrations with the technology (Hara & Kling, 2003) and time constraints due to other responsibilities (Keller, 1999) have all been identified as factors influencing students' decisions to withdraw from online courses. However, poor motivation has also been identified as a decisive factor in contributing to the high dropout rates (Artino, 2008; Keller, 2008). Therefore, student motivation is considered a crucial factor for success in online learning environments (Artino, 2008; Keller, 2008) and is a primary reason for the current study. Collectively, these factors point to the need to reconsider motivation to learn in technology-rich environments.(Maggie,2016).

“Motivational constructs” was identified by Zornei(2001) in order to make students realize the fact that intrinsic\extrinsic and integrative and\instrumental are two motivational constructs that complement each other. They are connected through their relation to the same motivational construct ,but on the other hand , they are connected through their interrelated features which can be well intertwined and rooted within one individual. “Intrinsic motivation is defined as the doing of an activity for its inherent satisfactions rather than for some separable consequence(Ryan & Deci,2000b, p56). Intrinsic motivation often results from the challenge, interest or fun an individual derives from an activity. Intrinsic motivation has also been identified as an important characteristic of online learners (Shroff, Vogel, Coombes, & Lee, 2007). Huett (2008)also suggests that online learner are more intrinsically motivated compared with their on-campus counterparts at both undergraduate and postgraduate level. The characteristics of independence, self-direction and intrinsic motivation have long been associated with distance learners (Moore, 1989).In contrast, “extrinsic motivation is a construct that pertains whenever an activity is done in order to attain some separable outcome” (Ryan & Deci, 2000a, p. 60). In other words, intrinsic motivation is associated with undertaking an activity for the enjoyment or interest inherent in it. Extrinsic motivation is associated with a source outside the activity itself, such as undertaking a course of study to improve future career prospects.

The impact of source is believed to be satisfactory motivation and supported student’s encouragement as well as identified motivation sources (Reber.2005,Gary”Lee”Frantz,2000). James W.King identified that , most sources were related to:

- Technologies and multimedia
- Organization and course quality
- Website construction, online interaction
- Accomplishing tasks, knowledge acquisition

The impact of interaction among participants is considered as dominant motivational development in virtual learning. Interaction has been used in online learning to denote anything from clicking on a link to interpersonal dialogue among many participants(Nicholas,2008).Moore identified three types of interaction in earlier generations of distance education, namely: *learner-instructor, learner-content, learner-learner interaction*. The former ,*learner-instructor* interaction refer to exchanges that occur between learners and the teacher are characterized by attempts to motivate and interest the learner. They also provide a mechanism for feedback allowing clarification of misunderstandings .Seven types of distance learning settings was identified by Thach and Murphy(1995):

- 1) establishing learning outcomes;
- 2) providing feedback;
- 3) facilitating information presentation;
- 4) monitoring and evaluating student progress;

- 5) facilitating learning activities;
- 6) facilitating discussions;
- 7) determining learning needs and preferences

Learner-content interaction describes the intellectual process that occurs between the learner and the resources associated with the topic of study (Moore,1989).With the rapid development of technology ,learners can now choose from a huge variety of information at any time or from any place. But in order to interact with content ,learners need to be able to access relevant and appropriate resources which frequently, requires guidance from the teacher(T.Anderson,2006)

Learner-learner interaction take place between learners taking a course together(Moore,1989).This can include processes such as sharing information and understandings, working together to interpret and complete activities, solving problems, and sharing opinions or personal insights.

The impact of digital tools is considered by learners to use the necessary technological tools to learn online has also been found to be related to performance(Moos&Azevedo,2009).It is the fact that ,the technology itself is viewed by some as inherently motivating because it provides a number of qualities that are recognized as important in the fostering of intrinsic motivation, namely challenge, curiosity ,novelty and fantasy(Lepper&Malone,1987).Juwah argues that for learners to participate and positive peer interactions ,they need know how to effectively use the digital tools and must understand how to learn. Bekele presumed that if students perceive technologies as easy/friendly, they would accept and use them, which then might affect their motivation and satisfaction. Perceived or actual use of technologies might also affect success. If users have dependable access to different technologies, that should have a favorable impact. Moreover, online collaborations and communications are possible only when one has multiple tools at hand. Thus, asynchronous technologies and multimedia presumably impact successfulness along with skill/experience factors. Technology factors is the most visible in virtual teaching and learning process.

The impacts of course projects and activities

Implemented interactive projects and activities among students in the online course are group or peer group assignments. Randomly, teachers assigned students into different groups. These groups or peer remain stable up to till the end of the course. Completing the project hand in hand by group or peer helps corporate and sustain mutual motivation and experience. Virtual based projects and activities focuses on collaborative skills as they accomplish assignments. Creating such interactive atmosphere electrify learners to become involved, interact with information and acquire knowledge. Dr. Hossein Arsham (Hopkins University) believed Web-based courses that engage and empower students increase their enjoyment and encourage them to share and participate in their learning process. The Internet can make it much easier for students to work

together. However, in collaborative learning the following is necessary for successful teamwork. The team must be a real team, rather than a team in name only.

- It has compelling direction for its work.
- It has an enabling structure that facilitates teamwork.
- It operates within a supportive educational context.
- It has expert teamwork coaching.

Motivation affects the demonstration of critical thinking skills and acquisition as well as it has been identified as a attributive factor in electrifying and providing a sense of community and achievement in Online-Supported learning. Picking up focal points of the article, not only technology attributes, course elements, contents, interaction, program quality but also project related activities reportedly motivated students . Compared to classroom learning environments, The scope of virtual teaching and learning process is less structured and leaner-focused .Taken together, project-oriented impact in online learning demands stable effort and persistence. Students who encounter obstacles related to support, technicalities and higher-order thinking skills have a higher motivation by persistence.

References:

- 1.Artino, A. R. (2008). Motivational beliefs and perceptions of instructional quality: Predicting satisfaction with online training. *Journal of Computer Assisted Learning*, 24(3), 260-270. doi: 10.1111/j.1365-2729.2007.00258.x
- 2.Bekele, T. A. (2010). Motivation and satisfaction in internet-supported learning environments: A review. *Educational Technology & Society*, 13 (2), 116-127.
- 3.Dornyei,Z(2001) Motivation and Second language Acquisition.Second Language Teaching and Cirriculum Centre, University of Hawaii at Manoa

SATIRICAL JOURNALISM, ENVIRONMENTAL PROBLEMS AND THE VALUE OF WATER

Annotation: This article focuses on social issues, namely ecological and water problems that are described in the compositions of T.Jumamuratov, including his satirical works. The poet of satires feels the importance of ecological problems in Karakalpakstan and highlights it in his literature works. The relationship and communication between people come in the first place. In his works the evil attitude of people to nature, social changes, the emergence of the term "human ecology", the sudden changes in nature are described. The author describes that any kind of issue arises as a result of this relations with a journalistic pathos.

Key words: satire, publicism, ecology, issue, water, people, social, nature.

In his book *The Third Wave*, Western futurist Alvin Toffler divides society into three groups and describes them. The first society: from ancient period to XIX century agrarian society. In this society, land ownership came first. Whoever owns the land is considered rich.

The second society is an industrial society. Whoever had the equipment was powerful.

The third society is the information society. In this case, those who have the information were the judges. All the conveniences, because civilization is in the city, everyone aspired to the city, tried to be educated, technical. Noisy and narrow streets began to crowd people, especially educators. Now they are interested in nature and quiet places.

In turn, humanity once again proved that it can not do without nature, without inspiration from nature.

Ecology is the biological science that studies the interaction of living organisms with the center of life. In modern times, ecology has become a science that studies the relationship between nature and society. It shows that man and nature are inextricably linked. Deterioration of the ecological situation significantly reduces the quality of life of people.

So, we are living in an information age where the advantages of nature are very clear. However, one example of the contradiction of life, in an age of increasing value of nature, is the high level of psychology that harms nature. When talking about the pros and cons of globalization, the negative side is the "increase in environmental problems."

During the writing of the work, I noticed a number of personalities of Tileubergen Zhumamuratov, both in relation to environmental issues.

In almost all works of poet, water, river and sea are the main ideas. He wrote a lot about water, rivers and seas. For example, "On the wave", "In Muynak", "By the sea", "Island", "To the fisherman", "Fishermen's union", "In the middle of the ocean" and others.

In the creation of the image of the poet, in simple words, in the utterance - the concepts of water, river, sea, ocean, waves pass through like a "golden thread".

In the work of poet there are ecological problems in prose journalism - speeches, articles, poetic journalism, satire. For example, speeches on the Aral Sea exercise, satirical journalism such as "Do not play too much with the sea", "The hot story we saw".

And the discovery is a great memory, reminiscent of the Aral Sea, which was flooded by the creation of Tileubergen Zhumamuratov. Tileubergen Zhumamuratov, a poet who wrote about the Aral Sea in the most beautiful way and wrote about it with the greatest skill.

T. Zhumamuratov's creations are like a sacred bird, and the spring breeze passes from generation to generation with a different symbol.

From the lyrics of poet written in the 1940s, we can see that he was a great satirist with a burning heart.

Surprisingly, Tileubergen Zhumamuratov wrote a feuilleton in 1947, "Don't play too much with the sea." The events that led to the feuilletons "Do not play too much with the sea", "The hot story we saw" are, as mentioned above, the indifference of the people, the resulting problems.

Here we can clearly see the appearance of officials, who were negligent in their duties.

This means that Tileubergen Zhumamuratov has long felt the ecological problem.

His satire describes unfavorable events that preventing to the development of the life of our people. The arrogance of the individual in the management of the kolkhoz was a case of disregard for public property. And T. Zhumamuratov's satire did not fail to touch the guilty person.

«We used to memorize and recite all the poems of T. Zhumamuratov published in the newspaper,» said Kudaibergen Zhumaniyazov, a teacher in the Republic of Karakalpakstan.

In the play "Don't play too much with the sea" Auez is left behind, Vasilchuk and Baishek are lazy and negligent, Shora batyr's prey is left in the field, he is a hunter. Sarsen swelled the poppies, taught Sait as well, and followed in his footsteps. And Nikolai is a sleeper, he is careless. Makhambet, Ajims go duck shooting. It is said that Tazhibai drank vodka without leaving the market.

Usually, the poet create his work with love, and it can be caused by life events which should not be told about it. He confirms it himself.

In the winter of 1949, in the "Mashankol" area of Moinak, the collective farmers produced a lot of fish, and due to the negligence of the fish trust, some fish were lost. And without realizing their responsibility, they only blame the heads of individual points, the recipients, and offer them to the places of punishment. At that time, Tileubergen was working in Nukus.

The poet got acquainted with these materials and wrote a feuilleton for the newspaper "Kyzyl Karakalpakstan" entitled "Korgen isti ettik bayan". The feuilleton was published in a newspaper in January 1950.

1968, at an international conference, a world program called "Man and the Biosphere" was adopted. It adopted for the first time an international program on the protection and rational use of biosphere bioresources, which received an appropriate environmental description.

In 1971, the first European Conference was opened in Switzerland, where the issues of "Environmental Center", "Nature Protection" were discussed. In 1972, about forty different decisions were made in Sweden on environmental education and training, and in 1977 on environmental education and training in Georgia.

Today, 85% of human diseases are caused by the unfavorable environment (dust, dust). The first people to blame for the destruction of nature. This exercise deals with medical ecology. To summarize, these connections are called "Human-Society-Nature". Here is an example. We see the attitude of people and society as a whole to nature. Our teacher Malika Zhumamuratova made a video for the lesson "Theory of the Information Society".

It shows that a beautiful girl is standing, she looks beautiful, she is carefree, she doesn't care about anyone, she can not speak... A man from abroad came around the girl and smeared mud on her face. The second one came and looked at it and threw a bigger stone. The next ones pulled out their hair and glued the jars and waste. Then a Kamaz came and overtook the girl. The girl is suffocating. None of the people who saw it said, "Don't do that." The beautiful girl became blind and miserable because of people. Nobody thought about it and worried. This girl is a symbol of nature. Human cruelty to nature has put him to death. Nature is speechless. But there is a soul. He gave all he had to humanity, not half of his soul, as the mother's love for the baby.

But mankind has stolen, deceived, eaten, and acted dishonestly. He did not see each other's faults, nor did he see them, nor did he know them. Satisfaction, conscience, and conscience were left aside. We have destroyed the Aral Sea, tested the ozone layer, filled the oceans with waste. Instead, we are increasing the number of diseases and suffering ...

Thales: "The liquid element of the whole world is water, and everything that happens in nature is made of water, and they are transformed into water by the action of the whole world. This is because it is said that the earth is made of water. The earth is round, flat, and floats in the water like a ship surrounded by oceans. Water is the permanent and material source of everything in the world, it

is eternal, but it is said that something and the gifts that come from it are temporary. According to him, this world, the world is material eternity. It did not exist out of nothing and will not disappear from the bar, "he said. These ideas are the philosophy of Palestine about water. A number of scientists have studied the properties of water and have come to the following conclusions: Water improves or worsens depending on the nature of the information it receives. Water that received good, well-informed information did not duplicate each other, formed wonderful crystals, and water that heard bad news did not form any crystals.

Human ecology is not defined as a stable science as a new ecological science, and there are various opinions about it in the world literature. Human ecology teaches the most effective ways to solve political and economic problems and improves people's living conditions.

The solution to the problem of human ecology is, of course, legal literacy and moral integrity, which are the main regulators in the democratization of the governing and executive generation.

The lack of these qualities is a stumbling block to the progressive thinking of every age.

By changing nature, people create a new environment. The Center for Human Ecology studies the favorable and unfavorable impact on human life.

In short, man cannot predict the future without knowing the past. As a result, there is an exercise in ecology and culture. This is the relationship between ecology and humanity. The very principles of morality here are enshrined in law and international law. This is the connection between ecology and law.

References:

1. [https:// ru/ Wikipedia/org/ wiki/ Проблема](https://ru.wikipedia.org/wiki/Проблема).
2. Социальная проблема Оксфордский толковый словарь по психологии. Подюред а.Ребера,2002
3. Социальная проблема.. Жмуров В.А
4. Большая энциклопедия по психиатрии,2-е изд,2012
5. Т.Жумамуратов Аралга келдим оралып, Нукус, «Каракалпакстан»
6. Т.Жумамуратов Омириннин ози философия, Н, «Каракалпакстан»,
7. Зарубина Ю.Н, Серова Е.А Социальные проблемы современного общества, Ярославль, ЯрГУ 2018
8. Бахадырова С Каракалпак поэзиясынын ошпес жулдызы, Н., «Каракалпакстан» ,2005

*Polvonov Kh.N.
assistant professor
of Karshi branch of TUIT
Khamrayev J.
assistant professor
of Karshi branch of TUIT
Jurakulov Sh.B.
assistant professor
of Karshi branch of TUIT*

THE STRUCTURE AND FUNCTIONS OF CLOUD PRODUCTION

Abstract: Very few people imagine that the concept of "cloud technologies" is not at all an unattainable area of IT technologies, but something that many people use on a daily basis. Cloud computing (eng. Cloud computing) is a technology of distributed data processing, in which computer resources and the provision of power to the user as an Internet service. The term "cloud" is used as a metaphor based on the image on the site of a diagram of a computer network, or as an image of a complex infrastructure that hides all the technical details.

Keywords: cloud computing, cloud structure, cloud computing functions, cloud product.

Cloud production is a new interdisciplinary field, involving technologies and concepts such as network production, production networks (MGrid), virtual production, flexible production, the Internet of Things and, in fact, cloud computing. Cloud production reflects both the model of "unity of distributed resources" and the model of "distribution of integral resources."

The concept of "cloud production" can be given the following definition - this is a model of universal, convenient access to the general fund of redeployable production resources (software, equipment, production facilities) at the right time and with the ability to quickly obtain a finished product with minimal management costs and with minimal interaction between the supplier and the customer.

In cloud production, distributed resources are encapsulated in cloud services and managed centrally. The client can use the cloud services at his discretion. The cloud user can receive various services: design training, design, production, testing, management and services related to any other stage of the product life cycle.

Consider the architecture of the cloud production system (Fig. 1).

As shown in the figure, a hypothetical cloud production system consists of many subsystems - "layers". Each of the layers contains software, hardware, technical, organizational, mathematical software separately or their combinations.

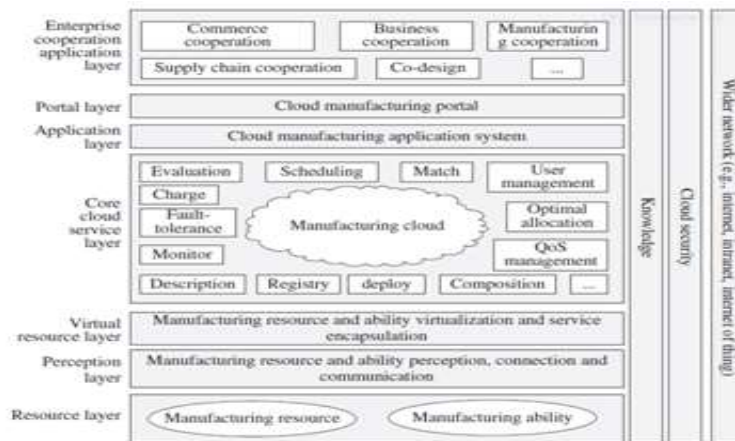

Fig. 1 - Cloud Production Architecture.

The functioning of the cloud production system begins at the corporate level (Enterprise cooperation application layer), which addresses the issues of versatile cooperation between industries and enterprises. Various enterprises, divisions and departments work under the general management of the software of the portal level (Portal layer) and the software of the cloud production system (Application layer). Here, the bulk of the tasks of human-machine interaction are carried out.

The most significant and time-consuming layer in this “pie” is the core cloud service layer, which combines all software and organizational and technical tools into a single production cloud (for example, receiving and processing applications, technical control, access rights management, planning, monitoring, capacity deployment, optimization, etc.). The effectiveness and efficiency of the entire production model depends on the functioning of this subsystem.

At the level of the virtual resource layer (Resource virtualization layer), production resources and capacities become "virtual" (more precisely, they create virtual copies through which communication with physical equipment is carried out) and encapsulated in the production cloud. The essence of encapsulation is to hide from "outside interference" the structure of the production site and to reduce the interactions between the cloud and production equipment to the use of strictly predefined methods and commands.

The connection layer (perception layer) provides data exchange between physical objects in the local network.

The resource layer contains all production resources and capacities encapsulated in services and available to the client upon request.

Outside the hierarchy are three subsystems, which simultaneously ensures the functioning of all other systems. This is a knowledge base, security system and a higher-level data exchange network (Internet, regional networks, etc.).

The subjects of the "cloud" production system are: a service provider (provider), which provides its production resources to the client, an operator who manages the platform, its maintenance and maintenance, and, directly, the client

himself who receives the necessary production capacity at the right time for a certain time fee.

Problems and development prospects

The new concept of industrial production is several steps ahead of the current opportunities of both industry and information technology, sets a good vector in the development of these industries.

Cloud production offers a transition from an obsolete production-oriented industry model to a service-oriented model. The key concepts are “production as a service”, “design as a service”, “management as a service”, etc. With the advent of powerful and affordable production services on the market, new opportunities for small businesses appear: the financial threshold for entering the market for newcomers is significantly reduced due to the possibility of obtaining production capacity in the right amount on a temporary basis, "for rent". In addition, there is access to powerful, reliable technologies that are easily scalable and rapidly deployable.

Industrial giants also win: idle equipment does not make a profit, and by placing it at the disposal of the “cloud” it is possible to ensure almost constant loading. In addition, a centralized industrial cloud management system, collaboration with other major market players will allow to achieve peak performance, implement and develop the latest technologies in the shortest possible time and in the most efficient manner.

The prospects for the new approach are very huge, but on the way to implementing such a system, enterprises will have to solve a number of serious problems:

- for the full-scale functioning of the cloud industry, the entire production cycle, from the warehouse of stocks to the warehouse of finished products, should be 100% automated;

- it is necessary to develop schemes for the technical control of projects at each stage of their implementation, starting with the technical specifications, ending with the shipment of finished products. This is due to the fact that potential customers of the system do not have access to detailed information about the production system, in addition, numerous production units encapsulated in the service make up an extremely difficult structure to understand, and customers may simply not have special knowledge in a particular technology field;

The concept of "cloud industrial production" demonstrates the enormous potential of the opportunities that the integration of information technologies in industry reveals, in the future it will be presented in the form of a completely new model, which is based on the synergy of classical industry and high technology.

Each level of the cloud production system poses a number of challenges for industrialists, for the solution of which significant investments, knowledge and experience of large companies in the field of cloud computing will be required, many new jobs will be created for specialists in new industries.

With the transition to a service-oriented industry, humanity receives an impetus in the development of a resource-oriented economy, it gets the opportunity to more rationally distribute production capacities and labor resources, the planning task becomes easier, the means of production themselves become goods that are easily divisible and exploitable.

References:

1. Xun Xu. From Cloud Computing to Cloud Manufacturing // Elsevier. Robotics and Computer-Integrated Manufacturing. Vol. 28, Issue 1, February 2012, p. 75–86.
2. Tao F., Zhang L. et al. Cloud manufacturing: a computing and service-oriented manufacturing model // Proceedings of the Institution of Mechanical Engineers, Part B: Journal of Engineering Manufacture, Institution of Mechanical Engineers, London, UK, 2011, vol. 225, no. 1

*Polvonov X.M.
Farg'ona politexnika instituti
O'zbekiston*

KALSIY XLORAT DEFOLIANTINI OLIISHDA TEXNOLOGIK HISOBLAR

Ushbu maqolada soda zavodi distiller chiqindisi xlorlangan aralashmasini natriy xlorati bilan konversiya qilib ikki suvli kalsiy xlorat olish jarayoni qaytar siklik usulda « Π_{100-1} »-« $P_{100}(\Pi_{20})$ »-« $P_{20}(P_{110}, \Pi_{20-1})$ »-« M_{20} » sxema bo'yicha amalga oshirilishi mumkin ekanligi ko'rsatib berilgan.

Tayanch so'zlar: paxta, defoliatsiya, distiller suyuqligi, xlorlash, konversiya, Eneke indeksi, xloratlar.

*Polvonov Kh.M.
Fergana Polytechnic Institute
Uzbekistan*

TECHNOLOGICAL CALCULATIONS FOR CALCIUM CHLORATE DEFOLIANT

The study showed that the process of obtaining two aqueous calcium chlorates by converting a chlorinated mixture of distilled waste from a soda plant with sodium chlorate can be carried out according to the scheme « P_{100-1} »-« $R_{100}(P_{20})$ »-« $R_{20}(R_{110}, P_{20-1})$ »-« M_{20} »

Keywords: cotton, defoliation, distillate, chlorination, conversion, Eneke index, chlorates.

Hozirgi kunda mamlakatimiz qishloq xo'jaligida ham chuqur tarkibiy o'zgarishlar amalga oshirilmoqda. Murakkab ob-havo sharoitiga qaramasdan, bu yil fermer va dehqonlarimizning fidokorona mehnati va omilkorligi tufayli 2020 yilda Respublika bo'yicha 1 million 78 ming gektar sug'oriladigan maydonda g'alla, 1 million 33 ming 629 gektar maydonda paxta etishtirildi.

Defoliatsiya jarayonini o'tkazish etishtirilgan hosilni sovuq tushmasdan oldin o'z vaqtida, tez va sifatli yig'ib terib olishni ta'minlaydi. Defoliatsiyadan keyin qator orasiga yorug'lik tushishi, issiqlik va havo aylanishi yaxshilanadi, natijada ko'saklarning etilishi va ochilishi tezlashadi. Defoliatsiya sababli yig'im terim ishlarining unumdorligi yaxshilanadi. Biroq, Respublikamizda mahalliy xom-ashyolar asosida olinadigan yuqori samaradorli defoliantlar ishlab chiqarish mavjud emas va bu muammo hozirda juda dolzarbdir.

Mamlakatimizda ishlab chiqarilayotgan va qishloq xo'jaligida keng miqyosda qo'llanilayotgan magniy xlorat defolianti tarkibida 42%gacha ta'sir

etuvchi modda hamda oz miqdorda fiziologik aktiv bo‘lmagan magniy va natriy xloridlari tutadi. Xloratlar guruhi defoliantlarining yana bir vakili – kalsiy xloratdir. Ushbu defoliant ilgari Rossiyadan olib kelingan va Respublikamiz qishloq xo‘jaligida keng qo‘llanilgan. Suyuq kalsiy xlorat-xlorid defoliantini ishlab chiqarish Usolskdagi “Ximprom” ishlab chiqarish birlashmasida amalga oshirilgan. Suyuq kalsiy xlorat-xlorid defoliantining fizik-kimyoviy xossalari qoniqarsiz edi. Mahsulotda ta’sir etuvchi modda – kalsiy xlorati miqdori 28,0% dan ortmas, kalsiy xloridi esa 25-26% ni tashkil qilardi.

Ammiakli usulda kalsinirlangan soda ishlab chiqarish jarayonida ko‘p miqdorda zararli chiqindi – distiller suyuqligi paydo bo‘ladi. Xar bir tonna soda ishlab chiqarishda $8 \div 10 \text{ m}^3$ distiller suyuqligi hosil bo‘ladi. Distiller suyuqligi – tarkibida kalsiy va natriy xloridlari, kalsiy sulfat va kalsiy gidroksidlarini tutgan eritma bo‘lib, komponentlarning umumiy miqdori 15-16%ni tashkil qiladi. Distiller suyuqligini qayta ishlashning istiqbolli usullaridan biri - uni yuqori konsentratsiyali kalsiy xlorat defolianti olishda ishlatishdir.

Shuni ta’kidlash joizki, soda ishlab chiqarishdagi ekologik muammolarning istiqbolli echimlaridan biri -chiqindilarni qayta ishlash orqali yuqori sifatli mahsulotlar, jumladan, paxta defoliatsiyasi uchun ishlatiladigan yuqori samaradorli kalsiy xlorat defoliantini ishlab chiqarishdir. Xlorlangan aralashma va natriy xloratini suvli muxitdagi konversiya jarayonini tadqiq qilishda olingan natijalar [2] kalsiy xlorat defoliantini xlorlangan aralashma tarkibidagi kalsiy xloridi va natriy xloratini 1:2 nisbatida, 100°C haroratda, bug‘latish bilan birga olib boriladigan konversiya jarayoni maqsadga muvofiq ekanligini ko‘rsatadi. Suyuq va qattiq xoldagi kalsiy xlorat defoliantini xlorlangan aralashma va natriy xloratini konversiya qilib olish jarayonini xisoblarini keltiramiz.

Xlorlangan aralashma va natriy xloratini konversiya jarayonini asoslash diagrammasi rasm 1.da keltirilgan. 100°C xaroratda natriy xloratini tarkibida ekvimolyar miqdorda kalsiy xloridi tutgan xlorlangan aralashma bilan aralastirganimizda tarkibi 4.4 rasmda « Π_{100} » nuqta bilan aniqlanuvchi pulpa xosil bo‘ladi. Eneke indeksi bo‘yicha « Π_{100} » pulpa koordinatasi 1 mol tuzlarga ion-ekvivalentda quyidagicha 2Na^+ - 0,4852; Ca^{2+} - 0,5148; 2Cl^- - 0,4853; 2ClO_3^- - 0,5147; H_2O - 6,6731.

Konversiya jarayoni umumiy tenglamasi quyidagicha:

$a \cdot (26,61\%$

$\text{CaCl}_2 + 8,15\% \text{Ca}(\text{ClO}_3)_2 + 2,73\% \text{NaCl} + 62,51\% \text{H}_2\text{O}) + b \cdot \text{NaClO}_3 =$

$$= \begin{cases} 1 \text{ ME } \langle \Pi_{100} \rangle \\ 2\text{Na}^+ - \underline{0,4852} \\ \text{Ca}^{2+} - \underline{0,5148} \\ 2\text{Cl}^- - \underline{0,4853} \\ 2\text{ClO}_3^- - \underline{0,5147} \\ \text{H}_2\text{O} - \underline{6,6731} \end{cases}$$

Bundan $a=0,5579$; $b=0,4421$.

Demak, $0,5579$ mol xlorlangan aralashmani $0,4421$ mol natriy xlorati bilan aralastirib, 100°C da to'yinguncha qaynatilganida, natriy xlorid cho'kmasi tutgan 1 ME (molyar birlik) « Π_{100} » pulpa xosil bo'ladi. Pulpani qattiq va suyuq fazaga ajratgandan so'ng natriy xlorid va rasm 4.4da koordinatasi « P_{100} » nuqtaga mos keluvchi eritma xosil bo'ladi:

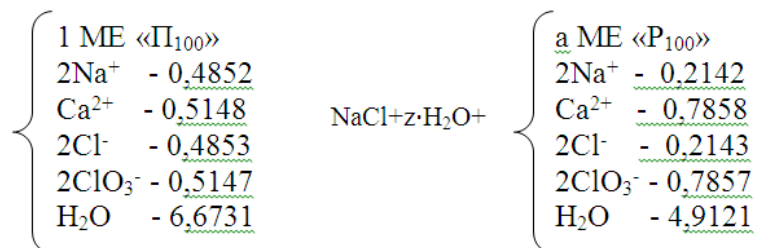

Kationlar, anionlar va suv bo'yicha xususiy tenglamalarni tuzamiz:

$$\begin{aligned} 2\text{Na}^+ - 0,4852 &= x + a \cdot 0,2142 \\ \text{Ca}^{2+} - 0,5148 &= a \cdot 0,7858 \\ 2\text{Cl}^- - 0,4853 &= x + a \cdot 0,2143 \\ 2\text{ClO}_3^- - 0,5147 &= a \cdot 0,7857 \\ \text{H}_2\text{O} - 6,6731 &= z + a \cdot 4,9121 \end{aligned}$$

Tenglamalarni echib quyidagilarni olamiz: $a=0,6551$; $x=0,3449$; $z=3,4552$. Shunday qilib, $3,4525$ suv bug'lahadi, « Π_{100} » pulpani filtrlaganimizda $0,3449$ mol natriy xlorid ajraladi va $0,6551$ ME « P_{100} » eritma xosil bo'ladi. « P_{100} » eritmani 20°C sovitilganida natriy xlorat cho'kmali $0,6551$ ME « Π_{20} » pulpa xosil bo'ladi. Ushbu pulpa koordinatasi « P_{100} » eritma koordinatasiga to'g'ri keladi. Xosil bo'layotgan eritma tarkibi NaClO_3 – « P_{100} » liniya bo'yicha davom etib, « P_{20} » nuqtaga to'g'ri keladi (rasm 1).

« P_{20} » eritma koorditanalari ion-ekvivalenda 1 mol tuz uchun quyidagicha $2\text{Na}^+ - 0,0595$; $\text{Ca}^{2+} - 0,9405$; $2\text{Cl}^- - 0,2565$; $2\text{ClO}_3^- - 0,7435$; $\text{H}_2\text{O} - 5,8796$.

$0,6551$ ME « P_{100} » eritmani 100°C dan 20°C gacha sovutish jarayoni tenglamasi:

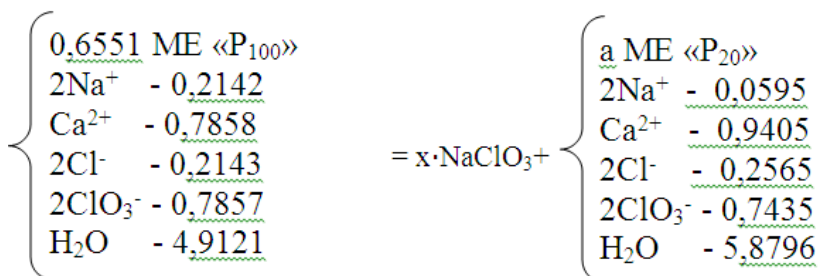

Kationlar, anionlar va suv bo'yicha xususiy tenglamalarni tuzamiz:

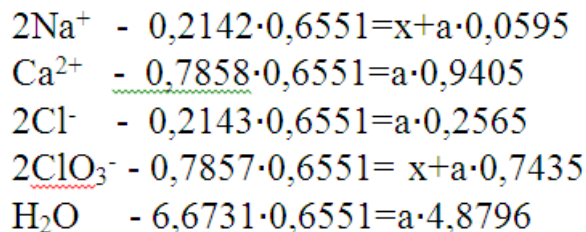

Tenglamalarni echib quyidagilarni olamiz: $a=0,5473$; $x=0,10776$.

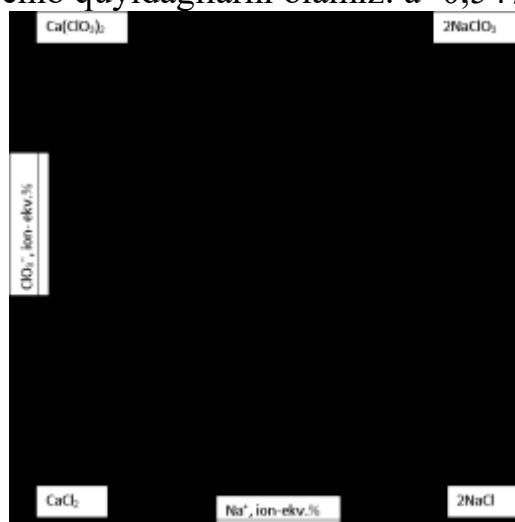

Rasm 1. Suyuq va qattiq xoldagi kalsiy xlorat defoliantini olish jarayonini asoslovchi diagramma.

Demak, 0,6551 «P₁₀₀» eritmani 100°C dan 20°C gacha sovitilganda 0,6551 ME «P₂₀» pulpa xosil bo'ladi, ushbu eritmani filtrlaganimizda 0,10776 mol natriy xlorat va 0,5473 ME «P₂₀» eritma xosil bo'ladi. Ushbu eritma tarkibida 53,25% kalsiy xlorat, 7,58% kalsiy xlorid, 2,41% natriy xlorid va 36,75% suv tutadi. Olingan eritma kristallanish xarorati +8°C bo'lgan, och sarg'ish rangli eritma bo'lib tayyor kalsiy xlorid defolianti hisoblanadi.

Kristall xoldagi ikki suvli kalsiy xlorat olish uchun 0,5473 ME «P₂₀» eritmadan bir qism suvni bug'latish talab qilinadi. Shuning uchun qaynash xaroratida va vaqtga bog'liq ravishda 0,5473 ME «P₂₀» eritmadan suvni bug'latish jarayoni tadqiq qilindi (rasm 2).

Olingan ma'lumotlar shuni ko'rsatadiki, «P₂₀» eritmadan suvni bug'latib, eritma konsentratsiyasini oshirib borish bilan eritmaning qaynash xarorati ortib boradi. 0,5473 ME «P₂₀» eritmadan 41,98-42,12% suv bug'latilganida 0,5473 ME «P₁₀₀» eritmada xosil bo'ladi. Eritma qaynash xarorati 100°C dan 110°C gacha ko'tariladi. Suvni bug'latish vaqti 23-25 minutni tashkil qiladi.

Ushbu eritma tuzli qismining koordinatalari 1 mol tuz uchun 0,5473 ME «P₂₀» eritma bilan bir xil bo'ladi. 1 mol tuz uchun suv miqdori o'zgaradi xolos. «P₂₀» eritmani bug'latish jarayoni tenglamasini tuzamiz :

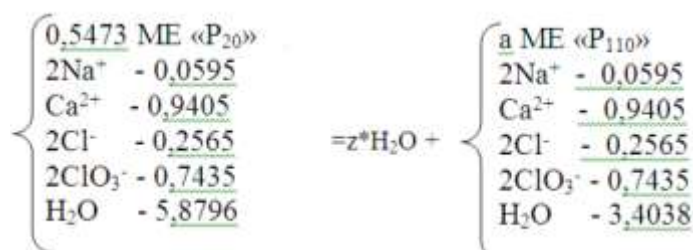

Kationlar, anionlar va suv bo'yicha xususiy tenglamalarni echib $a=0,5473$; $z=1,3550$ qiymatlarni olamiz. Demak, $0,5473$ ME «P₂₀» eritmadan $1,3550$ mol suvni bug'latib, $0,5473$ ME «P₁₁₀» eritmani xosil qilamiz, uni 110°C dan 20°C gacha sovutilganda ikki suvli kalsiy xlorat cho'kmasi tutgan «П₂₀₋₁» pulpa xosil bo'ladi.

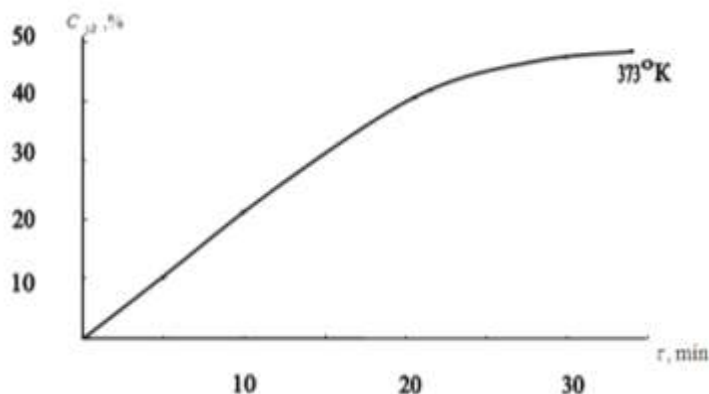

Rasm. 2. «P₂₀» eritmadan suvni bug'latish kinetik egri chisig'i.

Ushbu pulpa koordinatalari rasn 1.da $0,5473$ ME «P₁₁₀» eritmaga to'g'ri keladi. Pulpani filtrlaganda kristall xildagi qattiq ikkisuvli kalsiy xlorat va konversiya siklining boshiga qaytariluvchi «M₂₀» eritma xosil bo'ladi.

$0,5473$ ME «P₁₁₀» eritmani sovutish jarayonini tenglamasini tuzamiz :

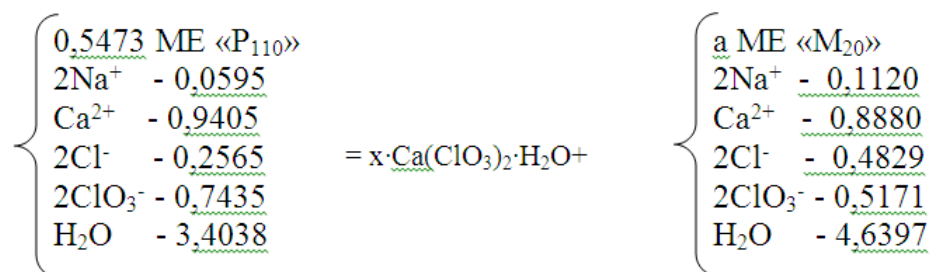

Suv va xar bir ion bo'yicha xususiy tenglamalarni tuzib va ularni echganimizda $a=0,2907$; $x=0,2566$. Shunday qilib, $0,5473$ ME «P₁₁₀» eritmani sovitganimizda xosil bo'lgan $0,5473$ ME «П₂₀₋₁» pulpani filtrlasak $0,2566$ mol ikki suvli kalsiy xlorat va $0,2907$ ME «M₂₀» aylanma eritma xosil bo'ladi.

«M₂₀» aylanma eritmani qo'llab olib boriladigan konversiya jarayoni uchun sarflanadigan xlorlangan aralashma va natriy xlorat miqdorlarini aniqlaymiz.

Konversiya siklini muvozanatda ushlab turish uchun natriy xloridli pulpani ajratilganidan keyin $0,6551$ ME «P₁₁₀» eritma xosil bo'lishi kerak. Xisoblar natijalari ko'rsatishicha konversiyada koorditalari $2\text{Na}^+ - 0,4354$; $\text{Ca}^{2+} - 0,5646$; $\text{Cl}^- - 0,4354$; $\text{ClO}_3^- - 0,5645$; $\text{H}_2\text{O} - 4,8456$ bo'lgan $0,9117$ ME pulpa xosil bo'lishi kerak.

Konversiya jarayoni tenglamasini va ionlar xamda suv bo'yicha xususiy tenglamalarni tuzamiz:

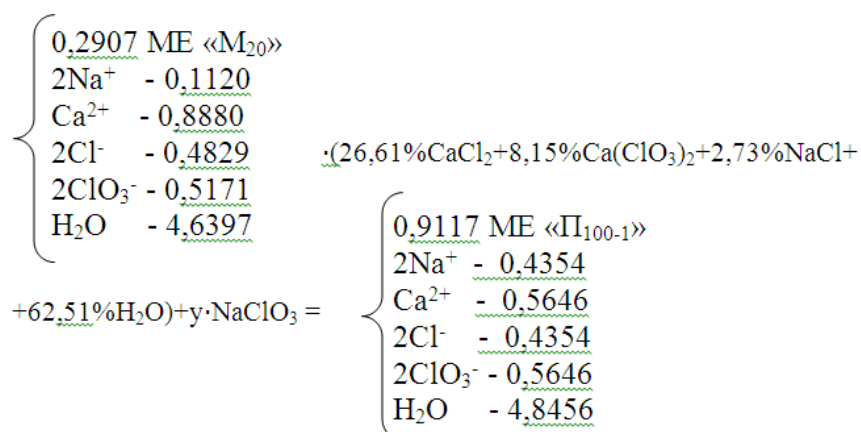

$$\begin{aligned}
 2\text{Na}^+ - 0,1120 \cdot 0,2907 &= y + 0,9117 \cdot 0,4354 \\
 \text{Ca}^{2+} - 0,8880 \cdot 0,2907 &= x + 0,9117 \cdot 0,5646 \\
 2\text{Cl}^- - 0,4829 \cdot 0,2907 &= x + 0,9117 \cdot 0,4354 \\
 2\text{ClO}_3^- - 0,4829 \cdot 0,2907 &= y + 0,9117 \cdot 0,5646 \\
 \text{H}_2\text{O} - 4,6397 \cdot 0,2907 &= x + 0,9117 \cdot 4,8456
 \end{aligned}$$

Xususiy tenglamalarni echib quyidagi natijalarni olamiz $x=0,2566$; $y=0,3644$. Demak, 0,9117 ME « Π_{100-1} » pulpani olish uchun 0,2907 ME « M_{20} » eritmaga 0,3644 mol natriy xlorati va 0,2566 mol xlorlangan aralashma qo'shish talab qilinadi.

0,9117 ME « Π_{100-1} » pulpani ajratganimizda 0,6551 ME « P_{100} » eritma va 0,2566 (m) mol nariy xlorid xosil bo'ladi. Bunda 3,14369 mol (z) suv bug'latilishi kerak.

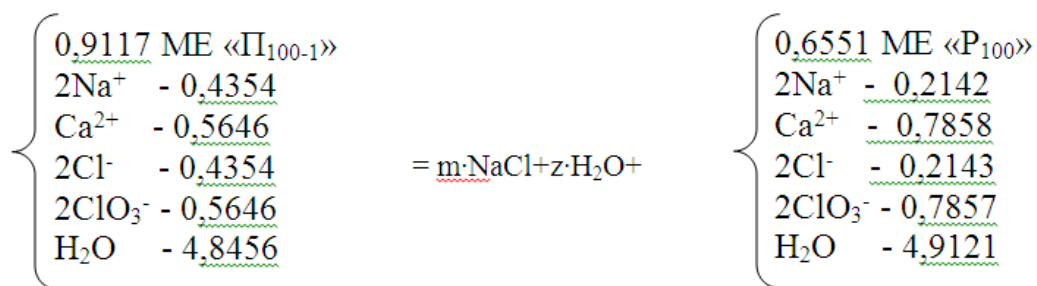

Davomida 0,6551 ME « P_{100} » eritma yiqoridagi usullar orqali ikki suvli kalsiy xlorati olishda foydalanilishi mumkin.

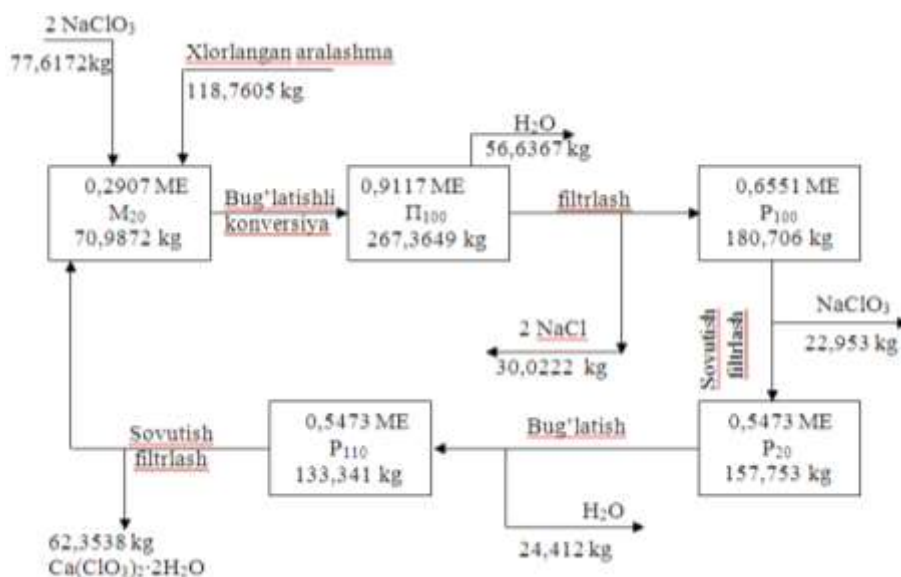

Rasm 3. Kalsiy xlorat defolianti olishning balansli prinsipial sxemasi.

Shunday qilib, soda zavodi distiller chiqindisi xlorlangan aralashmasini natriy xlorati bilan konversiya qilib ikki suvli kalsiy xlorat olish jarayoni qaytar siklik usulda rasm 3.da ko'rastilgan « Π_{100-1} »-« $\Pi_{100}(\Pi_{20})$ »-« $P_{20}(P_{110}, \Pi_{20-1})$ »-« M_{20} » sxema bo'yicha amalga oshirilishi mumkin ekan.

Foydalanilgan adabiyotlar:

1. Список химических и биологических средств борьбы с вредителями, болезнями растений и сорняками, дефолиантов и регуляторов роста растений, разрешенных для применения в сельском хозяйстве Республики Узбекистан на 2002-2006 годы. – Ташкент, 2002. – 96 с.
2. Полвонов Х.М., Хамдамова Ш.Ш., Давлятова З.М., Ибрагимова Г.О. Физико-химическое обоснование процесса получения хлорат-кальциевого дефолианта с использованием отходов содового производства. *Universum: технические науки: научный журнал.* – № 11(68). Часть 3. М., Изд. «МЦНО», 2019. – 96 с. – Электрон. версия печ. публ. – <http://7universum.com/ru/tech/archive/category/1168>, стр 14-26.
3. Полвонов Х.М., Домуладжонов И.Х., Домуладжонova Ш.И., Махмудов С.Ю. Нормативы предельно допустимых выбросов вредных веществ в атмосферу от куvasайского подсобного предприятия железобетонных изделий. *Universum: научный журнал.* – № 4(73). Часть 1. М., Изд. «МЦНО», 2020. – 72 с. – Электрон. версия печ. публ. – <http://7universum.com/ru/tech/archive/category/473>, стр 18-25.

*Pulatova M.
master of Plant Protection (biological method)
Tashkent State Agrarian University*

APPLICATION OF ENCARSIA PARASITE AGAINST TYPES

Annotation: Satisfying the demand of the population for food and industry for raw materials remains one of the most important tasks facing our country today. The successful accomplishment of this task depends in many respects on the efficient use of all the reserves of agricultural production. This is because many pests, diseases and weeds cause damage and destruction of plants, which reduces plant productivity. One such pest is the whitefly, which is currently being treated with precursors.

Keywords: Whitewash, organic products, agriculture, greenhouse, weeds, pyrethroid.

The main direction of obtaining a clean ecological product in agriculture is the biological properties of the soil, the management of the life of living organisms in it, the number and quality of soil organisms, the stability of their populations and the organization of agro-technical measures, biological management. In the 1980s, S.A. Alimukhamedov and B.P. The Adashkevichs brought the whitefly parasite *Encarsia* and erythromycin to our homeland from Israel and propagated it in greenhouses. Later, these parasites spread to greenhouses in Tashkent region and cotton fields in Khorezm region. The importance of the parasites mentioned above is enormous today.

Much of the evidence proven in practice in strategic plant protection requires less use of pesticides in protecting crops from pests. In particular, about 900 biolaboratories and bio-factories have been set up in Uzbekistan for the mass reproduction of trichogramma, bracon, *encarsia*, *pseudophicus* and other productive entomophagous and their control against pests of cotton, vegetables and other agricultural crops. lib, systematic control of crop fields not only drastically reduced the amount of pesticides applied, but even limited the use of insecticides in some areas. Natural ecosystems are free of pests and weeds. Even agroecosystems have more beneficial species than harmful ones. Therefore, it is important not to reduce the number of species that control the natural state, but to keep their population stable. It should be noted that the biological method is not useful if the biological method is applied to the area where it is used, and the areas close to it are treated with pesticides.

Encarsia is a small bee. Its body length usually does not exceed 6 millimeters. In men, the head and chest are black, in women the abdomen is painted light yellow. The reproductive model of these insects is parthenogenesis, in which female gametes develop without fertilization, so males make up more

than two percent of the total population and appear only with a sharp deterioration in weather conditions. Under favorable conditions, the total duration of development of the insect is about two weeks, but when the air temperature drops to + 18 ° C, it can be delayed up to a month. Encarsia is excreted every 2 weeks in the form of infected pupae at a rate of 5-6 pieces / 2m and 10-15 pieces / 2m for pest control. Environmental conditions: Optimal environmental conditions for entomophagous: air humidity up to 60-70%, temperature 26-29 ° C. At temperatures above 30 ° C or humidity above 90%, the productivity and survival rate of entomophagus decreases. The lowest temperature limit for the use of a parasitoid ditch is 13–14 ° C, but with a decrease to 17 ° C, Encarsia search activity is significantly reduced.

The main method of reproduction in encarche is parthenogenesis; males (usually about 2% of the total population) appear only under the influence of low temperatures during development. The female lays about 10-15 eggs per day in the bodies of whiteflies and pupae. The developmental duration of encarcation from egg to imago is 15 days at 26 ° C and 32 days at 18 ° C. Infected pupae darken or appear black spots on the dorsal side, making it easier to monitor entomophagous and assess the level of pest control. Adults emerge from infected pupariums. The bee also feeds on hemolymph of honey and algae larvae, piercing them with ovaries. Encaria is able to find prey at a distance of 15-20 meters. Too much honey can interfere with the movement of the entomophagous. The effectiveness of the use of Encarsia is affected by the duration of daylight hours (preferably 16-18 hours), brightness of light (7 thousand lux and more), humidity and temperature in the greenhouse.

Entomophagous culture does not tolerate treatment with insecticides of the pyrethroid group. Every year, with the onset of the spring-summer season, many insect pests wake up and begin to live an active life. Nowadays, due to the deterioration of the ecological situation, agricultural plant growers are trying to use biological means of protection, and for this purpose are increasingly using useful representatives of the animal world. Entomophagy is characteristic of a large number of insects that use pests as a food source for their offspring as a phenomenon of their own consumption, thereby limiting their reproduction. The method allows to avoid pollution of the environment, as these plants are treated with pesticides and do not cause dependence on pests.

One of the most striking representatives of entomophagous is the encarsia bee (lat. Encarsia formosa Gah.) - a parasitoid insect that destroys the population of white larvae that damage flowers, ornamental plants and vegetables (especially tomatoes and cucumbers), so it can be used in greenhouses, greenhouses and greenhouses. The adult insect (imago) feeds on honey and the hemolymph of the larva, which is perforated by its ovipositor (hemolymph is a fluid that circulates in the internal vessels and intercellular spaces of the "host insect"). During the day, one female of the parasite is able to lay 10 to 15 embryos larvae in the body and pupae (pseudococci) and lays 60 to 100 eggs in just one

season. From the embryo of the encarche develops a larva, which pupates inside the shell of the host. As a result, the pupae that infect the entomophagous embryo darken, which allows immediate detection of larvae infected with the parasite. The ideal conditions for the reproduction of these entomophagous - the ambient temperature is +28 ° C, relative humidity is 70% and the length of the day is 16-18 hours. It should be borne in mind that when the air temperature in the greenhouse is above +30 ° C and the humidity level exceeds 90%, as well as when it drops to +14 ° C, the activity of the enkaria and its survival rate decreases sharply. It is worth noting that adult insects (imago) can find white larvae at a distance of up to 20 meters. In this case, mainly the third and fourth drops of the pest are infected with pupae.

Regarding the question of how to control encarcation, I think the following should be done: When the adult whitefly population is first found in fields and greenhouses, when the number of adult pests (imago) is still low, encarcation can be started a week before planting. In case of severe infection, entomophagous puppets should be placed in beds every two or three meters, so that their total number per square meter should be at least three to five.

If the infection of whitefly larvae in the field or greenhouse accounts for about 40% of the total population of the pest, the introduction of encarcation should be considered successful. If, after the parasites are activated, the greenhouse infection remains high enough (more than 70% of the larvae have never been infected by the ensar), observe the ratio of ten to fifteen white larvae of one parasite at the start of the next flight. Such a model of access provides complete control over the pest during the growing season. A more successful spread of this entomophagous is facilitated by a sufficiently high temperature inside the room, good lighting of the greenhouse, timely detection of infectious foci, and speed of response to the mass appearance of pests. As a natural cousin of whiteflies, we can mention mainly specialized parasites *Encarsia* (*Encarsia formosa*).

List of references:

1. National report on the state of the environment and use of natural resources in the Republic of Uzbekistan. T. 2012.
2. A. Ergashev, T. Ergashev "Ecology, biosphere and nature protection", - Tashkent, 2010
3. H. Tursunov, T. Rakhimova, "Ecology", Tashkent, 2014.
4. A. Ergashev, T. Ergashev, "Agroecology", Tashkent, New Century Generation, 2006

*Qiryigitov B.A.
teacher of department of chemistry and physics
Andijan Institute of Agriculture and Agro technologies
Uzbekistan, Andijan*

CHARACTERIZATION DIFFERENT METHODS OF APPROXIMATION AND INTERPOLATION AND THEIR IMPLEMENTATION IN MATHCAD AND MATLAB

Annotation: Computer modeling, as a type of technology, is currently one of the most important factors in accelerating scientific and technological progress. Today it is almost impossible to do design and calculation by hand.

Key words: computer, MathCAD, system, computer science, physics, mathematics, mechanics, astrophysics, mathematical formulas and signs.

MathCAD is a powerful software package for solving various mathematical problems with the ability to program. The MathCAD system occupies a leading position among all other mathematical systems. In addition to performing its mathematical functions, the MathCAD system is a very good text and graphic editor, in many respects not inferior to specialized programs.

MathCAD is a mathematical system in which the description of the solution of problems is set using the usual mathematical formulas and signs. The use of MathCAD in solving applied problems of a technical nature made it possible to dramatically increase the speed of calculations and the level of complexity of tasks. The skills and experience acquired during the execution will be important in graduate design, as well as engineering and scientific activities.

Computer modeling systems allow solving many issues and problems related to various industries, such as computer science, physics, mathematics, mechanics, astrophysics and others. In our case, using computer modeling systems such as MathCAD and Matlab, we investigate the mathematical model of the RLC circuit.

Using the Mathcad system, calculate the values of the functions of current in a circuit and voltage across a capacitor in a given electrical circuit under the influence of given values of current, voltage and EMF. Investigate the effect of a variable inductance on the minimum voltage across a capacitor.

In a broad sense, a numerical method is understood as a set of a discrete model implemented on a computer and a computational algorithm that allows solving a discretized problem. One and the same mathematical model can be associated with many discrete models and computational algorithms, i.e., numerical methods. When choosing a numerical method, it is necessary to take into account two groups of requirements:

- the discrete model must be adequate to the mathematical model;

- the numerical method must be correct and implementable on the computer.

To ensure the adequacy, the discrete model must have the properties of the convergence of the numerical method, the implementation of discrete analogs of conservation, and the qualitatively correct behavior of the solution. The convergence of the numerical method, for example, means that as the step of dividing the integration interval decreases, the accuracy of the numerical integration increases. Various mathematical models are expressions of physical conservation laws, therefore, for a discrete model, conservation laws must also be satisfied. Qualitatively correct behavior of a discrete model means that due to the discrete nature of the model's behavior, some details of the behavior of the real system are not lost. The correctness of the numerical method means that the discrete problem must be unambiguously solvable and resistant to errors in the initial data and calculation errors.

When using analytical methods, the solution to the problem can be expressed using formulas. In particular, if mathematically the task is to solve the simplest algebraic equations, differential equations, etc., then the use of techniques known from the course of mathematics immediately leads to the goal. Unfortunately, in practice, these are too rare cases. The main tool for solving complex mathematical problems in accordance with are numerical methods that make it possible to reduce the solution of a problem to the execution of a finite number of arithmetic operations on numbers; the results are obtained as numerical values. Many numerical methods were developed a long time ago, but when calculating manually, they could only be used to solve not too time-consuming problems. When using analytical methods, the solution to the problem can be expressed using formulas. In particular, if mathematically the task is to solve the simplest algebraic equations, differential equations, etc., then the use of techniques known from the course of mathematics immediately leads to the goal. Unfortunately, in practice, these are too rare cases.

In engineering practice, it is often necessary to obtain an analytical functional dependence from the results of an experiment given by a tabular function. This process is called approximation or approximation.

Interpolation uses the values of some function, given at a number of points, to predict the values of the function between them. In Mathcad, you can either connect data points with straight lines (linear interpolation) or connect them with cubic polynomial segments (cubic spline interpolation).

Unlike regression functions, interpolation functions define a curve that exactly passes through specified points. Linear prediction is about using existing data values to predict values outside of them. Mathcad has a function that allows you to predict future data values based on existing data.

Application of the Mathcad and Matlab system for the study of a mathematical model of an electrical one, which includes an EMF source, resistance R , capacitance C and inductor L .

Complete problem statement with the use of the Mathcad system:

- Calculate the values of the voltage functions on a capacitor in a second-order circuit with a step action $E(t)$. Plot these functions
- Investigate the response of the oscillating circuit to external influences at various values of the variable inductance parameter. Construct graphs of functions of voltage across a capacitor for different values of a given variable parameter in one field.
- Calculate the analytical approximating function of the dependence of the minimum voltage value on the inductance according to the research results of the previous paragraph. Build graphically the original and approximating dependencies.

As a result of the work, he investigated the use of the MathCAD system for studying the mathematical model of the RLC circuit, calculated the values of the functions of the current on the coil and the voltage on the capacitor at various EMF. Has built graphs of these functions. Investigated the influence of the values of the variable parameter on the form of the voltage function in the circuit. Constructed a summary graph of all obtained stress functions in one field. An analysis of the results obtained showed that the voltage directly depends on the change in the capacitor inductance.

In the course of the completed work, a study was made of the mathematical model of the electric RLC circuit using the computer mathematics systems MathCAD and Matlab.

The use of mathematical modeling using the latest computer technology helps to greatly facilitate the most complex mathematical calculations. Over time, the latest developments in the field of computer modeling are expanding their application in a wide variety of areas of human activity.

The emergence of products such as MathCAD and Matlab and their improvement is driven by the need to perform complex mathematical calculations. These systems can greatly facilitate the work in the field of complex and time-consuming mathematical calculations.

In conclusion of this work, I studied the mathematical model of the RLC circuit, and also studied the computer modeling systems MathCAD and Matlab.

References:

1. Bessonov L.A. Theoretical foundations of electrical engineering. Electric circuits: Textbook for electrical engineering, energy, instrument making specialist. universities. 7th ed., Rev. and add. - M.: Higher school, 1978. -528 p.
2. Qiryigitov B.A. Installing The Web Application Creation Environment // Economics and society. - 2020.
3. Tarasik V.P. Mathematical modeling of technical systems, -Mn.: DesignPRO 1999 - 640 p.
4. Stephen Schafer. HTML, XHTML and CSS. The user's Bible, 5th edition = HTML, XHTML, and CSS Bible, 5th Edition. - Moscow: Dialectics, 2011.

Qodirova G.T.
teacher of department of foreign languages
faculty of agro engineering and hydro melioration
Andijan Institute of Agriculture and Agro technologies
Andijan, Uzbekistan

THE MODERN METHODS OF TEACHING BASIC LANGUAGE SKILLS

Abstract: Effective language training includes all four language skills: listening, speaking, reading and writing. All of them are important and can not give preference to only certain types when learning a foreign language. But it is an aid in the capture of oral language and reading. It should be borne in mind that when we talk about writing as an independent form of speech activity, then it is about writing.

Key words: Effective language training, educational process, teacher, classroom work, development, technology.

The main skill of FL learners is writing. A writing system is an organized regular method (typically standardized) of information storage and transfer for the communication of messages (expressing thoughts or ideas) in a language by visually (or possibly tactilely) encoding and decoding (known as writing and reading) with a set of signs or symbols, both known generally as characters (with the set collective referred to as a “script”). These characters, often including letters and numbers, are usually recorded onto a durable medium such as paper or electronic storage/display, although non-durable methods may also be used, such as writing in sand or skywriting [3].

A. Budagov defines a theory of writing - written speech. Written speech includes two types of speech activities: productive (writing) and receptive (reading). Written speech has no means of sound and intonation. Writing and written speech act primarily as a means and a goal of teaching, while learning a foreign language.

Written speech is also a basic form of existence of speech in the scientific, journalistic, formal, business and artistic styles.

2. Listening is the main goal of learning. In accordance with the requirement to base line language skills, work on three types of listening:

a) listening with a full understanding of the text perceived by ear (listening for detail);

b) listening with a total coverage of content, i. e, with only a basic understanding of information (listening for the main idea);

c) listening for becoming desired or information of interest (Listening for specific information);

Listening - a complex process of perception and understanding of speech by ear. Listening may be the aim, and the means of education. This type of speech activity plays an important role in the initial stage in the achievement of practical, developmental, educational and instructional purposes, and serves as an effective means of teaching the English language. For listening does not significantly so immediately understand the foreign-language speech (this is fully practically unlikely) as the ability to achieve understanding, correct verbally responding to emerging interference. Bim created the following objectives of listening:

Generate mechanisms listening:

the ability to distinguish phonemes;

the ability to distinguish intonemy;

the ability to discriminate rhythmic patterns;

to keep in mind the speech chain of different length;

to predict the content of the speech on the grounds of a formal speech.

Learning to understand the main content of relying on visual motor visibility, as well as gestures, facial expressions, rhythm, intonation and emotional support.

Listening allows you to implement educational, educational and developmental goals. It allows you to teach people to listen closely to the sounding speech, the ability to anticipate the shape semantic content of an utterance and thus foster a culture of listening not only foreign, but also in their native language. The educational value of formation of ability to understand speech at the hearing, is that it has a positive effect on the development of memory, and most of all auditory memory that is so important for learning a foreign language.

Listening is composed of perceived ability to differentiate sounds, integrate them into meaningful complexes, keep them in mind during the hearing, to carry out a probabilistic forecasting, and based on the situation of communication, understand the perceived sound chain.

The process of perception is in a certain normal rate, characteristic of a normal pace, peculiar to that language, from different sources, with natural disturbances of speech and non-speech character.

The next step of forming learning skills is reading. Reading - motivated, receptive, indirect form of speech activity flowing at the domestic level, aimed at extracting information from the written text of a fixed flowing through the processes of visual perception of any short-term memory and encoding information.

When learning a foreign language, reading is seen as an independent kind of speech activity has a leading position in its importance and availability.

It performs the following functions:

- imparts skills of independent work.
- text is often acts as a basis for writing, speaking and listening.
- educational objectives (ethics, philosophy, values).

- expanding horizons.
- Instills a love of books.

To achieve these objectives it is necessary to attach to the reading of fiction, journalistic, scientific and professional literature in a foreign language.

The basis of learning to read the following principles allocated S. K. Folomkina:

learning to read - this is the voice of learning, ie communication, not just a way to screen readers;

learning to read should be constructed as a cognitive process;

reading instruction should include, along with the receptive and reproductive activities of students;

learning to read involves reliance on the mastery of language structure.

Speaking as a kind of speech activity is primarily based on language as a means of communication. Language enables communication between communicating because it is understood as the one who communicates information, encoding it in the meanings of words selected for this purpose, and the one who receives this information by decoding it, ie deciphering these values and changing based on the information their behavior.

According to Lazareva speaking has many characteristics of activity, that means speaking has also the object and the result [3].

Belogradova (2004) also said that each vocal activity depends on the situation, conditions (circumstances, result), in which acts this saying.

Speaking - is verbal communication, ie verbal communication process with the help of language. Means of verbal communication are the words with assigned to them in the public experience of values [3].

The simplest kind of speech is a dialogue, that is, conversation, the interlocutors supported jointly discuss and decide any questions. Galskova and Getz wrote that dialogical speech is the form of speaking when occurs the exchange of sayings between two or more faces.

The second type of speech - a monologue that says one man, referring to another or to many people who hear it: this is the story of a teacher, a detailed recitation, report, etc. Also Galskova and Getz said: " in comparison with dialogical speech, monological is characterized by it's hugeness, that deals with the content of saying, availability of definite constructions and grammatical framing.

Monologue speech has greater compositional complexity, requires completion of thought, greater respect for the rules of grammar, rigorous logic and consistency in describing what to say uttering a monologue.

Methods which help to develop speaking skills - direct and communicative language teaching. The direct method, sometimes also called natural method, is a method that refrains from using the learners' native language and just uses the target language.

All countries share the right information with each other. English language-language of the world, the international language of communication. Internet also facilitates teaching. Also more and more people learn foreign languages. History of the Internet is very interesting. The Internet is used in teaching, education, learning, educational process, pedagogical process. Internet is very useful in teaching activities and teaching practice. But it is necessary to use the Internet in moderation and wisely. I made analysis of the role of foreign languages and the Internet. We have studied the information about modern methods of teaching the four basic skills in a foreign language: speaking, listening, writing and reading. But we should not forget about grammar, vocabulary and pronunciation. Because teachers of foreign languages have opportunities to teach speaking, reading, writing, listening, grammar, pronunciation and vocabulary. Foreign language teachers must teach students to all aspects of a foreign language. This is a very important and necessary, about this not necessary to forget.

List of references:

1. A guide to course and diploma design for electrical and energy specialties: textbook. manual. for stud. universities / under the editorship of V.M.Blok.– M.: Vyssh. school, 1981.– 304 p.
2. Egamberdiyeva D.U. The account of individual features of students in the process teaching english language. International scientific journal. Economy and society. № 6(73) -s.: 2020.
3. Moiseeva EV The study of foreign languages in the development of the Bologna process // P All-Russian (with international participation) scientific-practical conference "John novation competence and creativity in research and teaching of languages and kultur.- M .: RSSU 2011.
4. Usmonova Sh. Study of scientific technical transfusion in non-linguistic educational university. International journal. Moscow.2019.
5. Matkarimova G. Formation of the english scientific competence in students of non-factual faculties. International journal. Moscow.2019.
6. Sinitsina, GN Development of competence in project activities among students of technical specialties [Text]: dis. Cand. ped. Sciences: 13.00.08: protected 03/18/03: approved. 23.10.03. / Galina Nikolaevna Sinitsina. - Orenburg, 2003. –187 p. - Bibliography: p. 165-181.

*Qoraboyeva N.
teacher of department of foreign languages
faculty of agro engineering and hydro melioration
Andijan Institute of Agriculture and Agro technologies
Uzbekistan, Andijan*

THE ROLE OF FUNCTIONAL-COGNITIVE DICTIONARY IN DESCRIBING VARIOUS PHRASEOLOGICAL LEVELS

Abstract: The article deals with phraseological categories, phraseological units, their functions in the general system of language and the role of functional-cognitive dictionary in describing various phraseological levels.

Key words: phraseological units, collocations, cognitive, idioms.

At the present stage of the development of phraseology, the interest of researchers in the development of such theoretical directions is especially relevant, which will make it possible to look in a new way at the rich phraseological material accumulated over the centuries, turning to the problem of phraseological modeling, the mechanisms of creating phraseological units, constructing the concept of phraseological units, their mental image.

The further development of phraseology, as V.N. Teliya points out, consists in the development of new methods of description, developed in line with the grammar of the generative type and therefore "splicing" the methods of lexicology and syntax, on the one hand, and on the other, paying attention to such problems as conditions references, pragmatic functions, role in a speech act. Phraseology found itself within its own taxonomic boundaries, playing the role of an iron curtain between it and lexicology. Requires de-preservation of the phraseology itself and the integration of its results into the general description of the language in action [2, 52-53].

The functional-cognitive dictionary [3] contributes to the solution of this problem, since phraseological units are given in it against the background of extensive lexical material, which allows us to determine their nominative-taxonomic and cognitive functions, as well as their place in the general language system. The volumetric lexical background reveals a deep isomorphism between the nominative means of the language and phraseological categories that fill them in lexico-syntactic ways.

This functional-cognitive dictionary includes several categories of phraseological units. First, these are phraseological combinations, or lexical collocations. In this section of the dictionary, various types of related meanings are given, which make up a special set of phraseological units. Among them are substantive-adjective combinations: evil fate, bitter fate, tragic fate, sentimental conversation, peace negotiations, a loud phrase, an emergency situation, age-old

traditions, a dog's life, untimely death, tragic death, sudden death; verb-nominal combinations: pull out of the throat, publicize, criticize, etc.; combinations with the metaphorical use of words: corridors, echelons of power, a wooden ruble, a sphere of activity, a field of enlightenment, a bear's corner, white light, a gift of fate, pitch hell, earthly paradise, etc. ; various types of language clichés, "speech patterns", for example, formulas for greeting, politeness, opening a conversation, gratitude, offers of services, advice, etc. : best wishes, good hour, happy journey; happy New Year; to tell the truth, to tell the truth, to say all the best, do not remember dashingly, etc. A large place in the dictionary is occupied by lexical idioms as the core of phraseology. Idioms are equivalent to words in terms of their integral nominative function and are expressively colored. For example: to live below the poverty line, to drag out a miserable existence, to fight off home, to break a comedy, to bend one's soul, to fight like a fish on ice, to barely make ends meet, to let fog, in all honesty, pour out your soul, turn your soul out to a stranger, show your heels hitting your finger in the sky.³²

Phraseologisms supplement the nominative inventory of the language with the missing evaluative and expressive means, idioms are always richer in details [2, 84]. They, as a rule, describe such aspects of the designated phenomena, events, realities that remain not fixed in the main nominative units of the language. So, in the cognitive sphere of speech, not all signs of speech activity are expressed, and, naturally, they are supplemented by idioms. In idioms, participants in the situation are involved who are not represented among the main parametric characteristics, for example, instrumental act, ants, tongue, ears, means of articulating speech throat, pharynx, teeth, mouth: tongue loosened, keep his mouth shut, open his tongue, bite his tongue, porridge mouth, tongue braided, it broke off the tongue, screaming at the top of the throat, at the top of your voice, tearing your throat, tearing your throat / throat, bawling / bawling, squeezing through your teeth; tongue poorly / well suspended; weak on the tongue, long tongue, tongue without bones, tongue like a pomelo. Wed also: prick up ears, hang ears, ears on top of the head, buzz all ears, sing in someone's ears; give free rein to the tongue, it broke off the tongue, the devil pulled the tongue, chatter (grind, ruffle, scratch) with the tongue, call out the tongue, shut up the mouth, pull the tongue, the tongue does not turn, shorten the tongue. The listed idioms express such additional meanings as prohibition, involuntary, unintentional action, intensity, undesirability of action, quantitative, qualitative signs.

The specifics of the phraseological significance of the components of the phraseological unit, which manifests itself in their dependence on the corresponding denotative situation and the situation of use, as well as dependence on the figurative structure of the phraseological unit: someone has a tongue without bones, "someone is too talkative, speaks too much," someone's tongue

³² Ahmadjonova Sh.N. The use of neuro linguistic programming in the process of learning foreign languages. International scientific journal. Economy and society. № 6(73) -s.: 2020.

itches -or – “I want to say something, to speak uncontrollably.” Further, the author rightly emphasizes the anthropocentric nature of phraseology and its organic connection with active cognitive activity. In his opinion, the features of phraseological semantics are entirely determined by speech-thinking processes. Reflected in the minds of denotative situations, being associated with already existing knowledge, develop certain schemes of those situations that are actualized by means of secondary nomination. It is necessary for a phraseological designation of a speech-thinking element to reproduce in memory a direct unobservable situation or object [1, 248-256].

In all areas of the dictionary, there is an interaction of units of the lexical and phraseological levels. Phraseological units increase the cognitive potential of the paradigmatic class and cause a significant complication of the content and replenishment of the volume of the cognitive sphere. So, in the sphere of "living" phraseological units appear in different blocks, increasing their volume.

There are numerous phraseological units that express the theme of death: to lay hands on oneself, play in a box, give up the ghost, ghost out, end your days, give your soul to God, give up your ends, say goodbye to life, retreat into eternity, breathe your last breath, stretch your legs, to leave life, go to a better world, go to the grave, fall asleep in eternal sleep, put a bullet on the forehead; to lay on the spot, to bring to the grave, to put up against the wall, to wipe off the face of the earth, to drive into a coffin, to knock out the spirit, to release the guts, to bury.³³

With the help of phraseological units, phrases of being are transmitted: to enter into life; to stand with one foot in the grave, to breathe in incense, at death, on his deathbed, at the last gasp, the hour of death, at the end of days, in the declining years, until the grave, until the end of days, until the grave, until death, until the last breath ... The initial phase of the predetermination of being (fate) is expressed by phraseological units: to be born in a shirt, in a shirt; be born under a lucky star; written in the family.

Some phraseological units convey aspects of life support: to run aground, rolling around like cheese in butter, skipping bread for kvass, sitting on bread and water, dragging out a miserable existence; fatalities: by the will of fate, irony of fate, tempt fate; find a way out of the situation, origin and kinship: no clan and tribe, no clan or tribe, seventh water on jelly, blue blood; age: sand is pouring, not the first youth, old and small, in years, in years, years have passed, in old age; locality: under the open sky, under the moon, between heaven and earth, a place under the sun, at the end of the world, white light, in the next world, assessments: drink a bitter cup to the bottom, not see the white light, live like a bird of heaven, live in perfect harmony, eat someone else's bread.

Being most often vivid, figurative-emotional, expressive-evaluative means of the Russian language, it is phraseological units that contribute to the creation of a meaningful, expressive picture of the world, the originality of which lies in

³³ Jalolov Sh.U. Russian language of business communication in the contemporary cultural and educational space. International journal. Questions of sciences and education. № 11(95). 2020.

the perception of sensually tangible, visual images based on associative perception and perceived against the background of a holistic generalized-figurative meaning phraseological unit.

References:

1. Ahmadjonova Sh.N. The use of neuro linguistic programming in the process of learning foreign languages. International scientific journal. Economy and society. № 6(73) -s.: 2020.
2. Jalolov Sh.U. Russian language of business communication in the contemporary cultural and educational space. International journal. Questions of sciences and education. № 11(95). 2020.
3. David Crystal. English as a Global Language, Moscow: Ves Mir, 2001, 240 p.
4. Medvedev R. The phenomenon of globalization and the languages of the CIS // Russian newspaper. 2005.15 November .
5. Wikipedia . URL: ru.wikipedia.org
6. Encyclopaedia Britannica. Britannica Book of the Year. Chicago: Encyclopaedia Britannica, 2002.

*Sadullaev B.A.
student
Astanaliev E.T.
student*

*scientific advisor: Suyunbaev Sh.M., c.t.n.
Tashkent state transport university*

JAPANESE METHOD FOR FORMATION OF MULTI-GROUP TRAINS

Annotation: The problem of tracks for formation of pick-up trains, with the analysis and proposal of possible solutions, is considered in the paper. The results obtained show that the current practice in solving this issue has not been appropriate, that it does not provide good results and, hence, that it has to be changed.

Key words: technical cargo stations, Pick-up train formation methods, number and length of tracks

The Japanese method has been popular in technical freight yards due to a specific track solution. This method requires three shunting tracks, where the final feeder train forming takes place. The tracks must be interlinked with appropriate crossovers (most often with simple crossovers (Figure 1a) or double crossovers (Figure 1b)). Furthermore, all these tracks must have a downward grade of 2.5‰ and must be equipped with track brakes, radars, and axle counters. The central delivery track is usually by 50 to 80 mm higher than the end tracks, so that wagons can easier move to end tracks, depending on their use. In marshalling or classification yards, such track solutions can be:

- with only one track structure on which the final sorting is operated for all trains,
- with several track structures, where the number of such structures corresponds to the number of feeder trains to be formed at a particular yard, with several truck structures that are defined depending on the needs and expected effects.

This solution enables wagon sorting and grouping according to appropriate intermediate stations in a single classification effort, so that this phase is followed solely by grouping according to the order of intermediate stations. In the end, we could state that this solution is generally characterized by an increase in investment due to use of additional crossovers and track brakes, while on the other hand significant savings are made by shorter downtime of wagons.

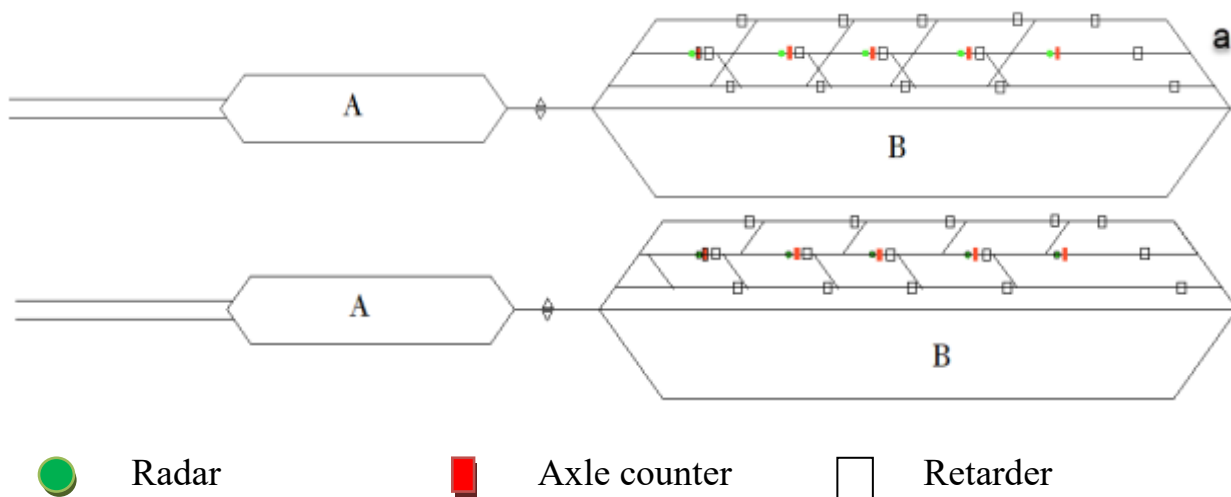

Figure 1. Technical solutions for forming feeder trains by Japanese method: a) with simple crossovers; b) with double crossovers

The technology for final feeder train sorting by means of the Japanese Method does not depend on the number of track structures contained in the system of these yards, but rather on the technical track solution, i.e. on the use of crossovers (simple crossovers (Figure 1a) or double crossovers (Figure 1b)). Here it is important that in each track group the central track assumes the role of delivery track, while two end tracks are used for wagon collection by intermediate stations. This is why both end tracks must have the number of parts that corresponds to the maximum number of intermediate stations at a distribution section for which feeder trains are formed (e.g. in Figure 2, there are 10 parts at end tracks (5 on each track) on which feeder train forming is possible for ten intermediate stations). The method of wagon forming or wagon collection at sections, and by intermediate stations, depends on crossovers used:

- if simple crossovers are used, then the use of parts at end tracks must correspond to the order of intermediate stations (on one side 1, 2, ..., 5, and on the other 6, 7, ..., 10, or on the one side 1, 3, ..., 9, and on the other 2, 4, ..., 10);
- if double crossovers are used, then the use of parts at end tracks can be arbitrary.

This solution enables wagon sorting and grouping according to appropriate intermediate stations in a single classification effort, so that this phase is followed solely by grouping according to the order of intermediate stations.

In the end, we could state that this solution is generally characterized by an increase in investment due to use of additional crossovers and track brakes, while on the other hand significant savings are made by shorter downtime of wagons.

Brief presentation of the Japanese Method

The technology for final feeder train sorting by means of the Japanese Method does not depend on the number of track structures contained in the system of these yards, but rather on the technical track solution, i.e. on the use of crossovers (simple crossovers (Figure 1a) or double crossovers (Figure 1b)). Here

it is important that in each track group the central track assumes the role of delivery track, while two end tracks are used for wagon collection by intermediate stations.

This is why both end tracks must have the number of parts that corresponds to the maximum number of intermediate stations at a distribution section for which feeder trains are formed (e.g. in Figure 2, there are 10 parts at end tracks (5 on each track) on which feeder train forming is possible for ten intermediate stations). The method of wagon forming or wagon collection at sections, and by intermediate stations, depends on crossovers used:

- if simple crossovers are used, then the use of parts at end tracks must correspond to the order of intermediate stations (on one side 1, 2, ..., 5, and on the other 6, 7, ..., 10, or on the one side 1, 3, ..., 9, and on the other 2, 4, ..., 10);

- if double crossovers are used, then the use of parts at end tracks can be arbitrary.

This solution enables wagon sorting and grouping according to appropriate intermediate stations in a single classification effort, so that this phase is followed solely by grouping according to the order of intermediate stations.

In the end, we could state that this solution is generally characterized by an increase in investment due to use of additional crossovers and track brakes, while on the other hand significant savings are made by shorter downtime of wagons.

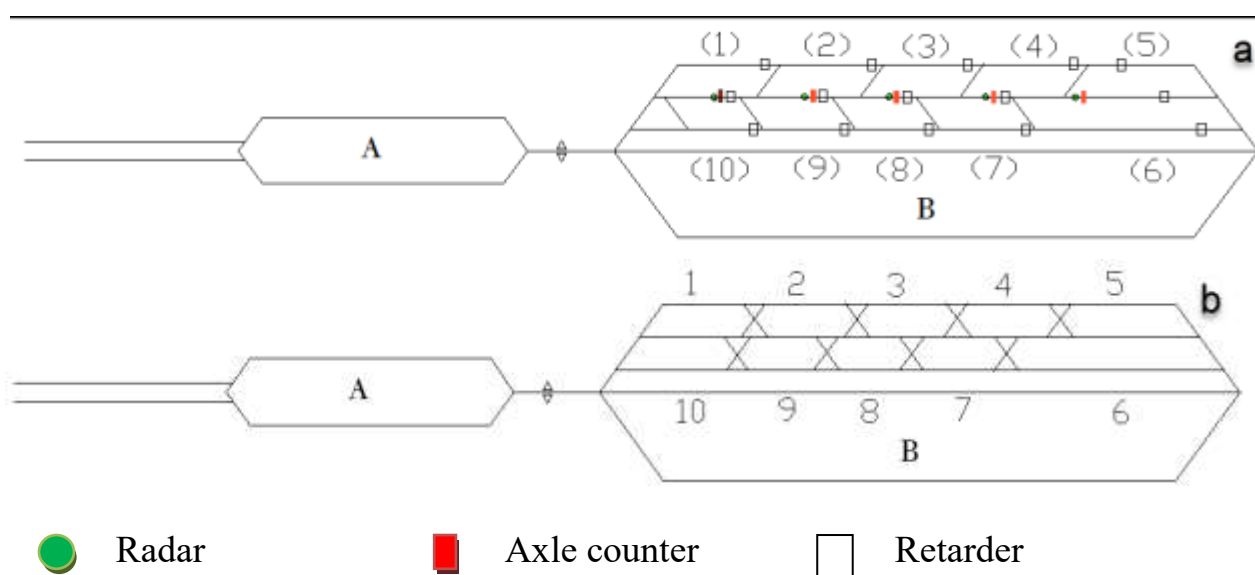

Figure 2. Track use during feeder train forming by Japanese method a) for solution with simple crossovers; b) for solution with double crossovers

Based on research conducted in this paper, and the corresponding analysis of results, the following conclusions can be made:

- Regardless of the method used, the process of feeder train forming can be relatively easily modelled and simulated by means of any programming language.

- Results of the model used show the real situation with regard to the use of analyzed methods, and point to a number of errors in the current design and operation of technical freight yards. That is why these results can be used as an additional argument for making significant technical and investment decisions during the design and operation of either new or renovated technical freight stations.

- Significant new indicators as to the use of these methods can be developed by broadening the base of input elements, and through additional analyses. A separate report (study) should be prepared in that respect.

- The establishment of this model has created favourable conditions, and has given an additional encouragement, for the participation of wider public and the authors themselves in the further development of the model through future study of this or other similar problems.

Method name	Parameters for application	Basic characteristics	Advantages	Disadvantage
Japanese methods	The technical solution for rail	Three shunting tracks mutually connected to a larger number of track connections	With briefly stopping wagons achieve significant savings	Increase in investments due to the use additional links of track and of track brakes

References:

1. Ivić, M.; Marković, M.; Marković, A.: Effects of the application of conventional methods in the process of forming the pick-up trains, Yugoslav Journal of Operations Research, 17(2007)2, 245-256
2. Zeleny, M.: Multiple criteria decision making, Mc Graw-Hill, New York, 1982.

Shaniyazova D.S.
senior teacher of the Department of Pedagogics, Psychology
and Education Management
of Kashkadarya RCRPEDPO

THE ROLE OF SPEECH IN IMPROVING THE PROFESSIONAL COMPETENCE OF A PRIMARY SCHOOL TEACHER

Annotation: This article focuses on the speech skills of an elementary school teacher and focuses on the teacher's speech culture, ways to realize the potential of primary school students by following the rules of speech.

Keywords: primary education, speech culture, speech technique, speaker, diction, facial expressions, pantomime.

Pedagogical activity is a profession that has been glorified since ancient times and requires a high level of skill, knowledge, patience and a culture of communication.

When a school introduces a child to the world of enlightenment, it must first teach him emotional cognition, and then mental, moral, and aesthetic cognition. We all know that a schoolboy tends to imitate his teacher and try to be like him in every way. In particular, it mimics the culture of the teacher's behavior, speech, and dress. One of the most important features of the effective organization of education is the high level of teacher speech culture. Therefore, the teacher should be very attentive to his speech when dealing with students.

Even in the works of Eastern thinkers in history, ideas about language, speech, speech etiquette are reflected. Therefore, if we take Mahmud Kashgari's "Devonu lug'atit turk", it says "Erdam bashi til", that is, "The tongue is the initial process of polite". With the help of this proverb, the thinker has brilliantly expressed the wise meaning that the beginning of human etiquette and morality can be seen in language and speech.

Alisher Navoi, the sultan of the Ghazal dynasty, skillfully summarized his thoughts on speech, speech etiquette, speech culture, and the art of speech. For example:

- One of the factors that determine a person's morality is his words and speech: the taste of water is like ice, the taste of soup is like salt, and the goodness of a person is like words.

As mentioned above, among the skills in the effective organization of pedagogical activity, the ability to speak is important for the teaching profession, because the transfer of information from teacher to student is mainly through secondary signals, the nature of speech. The teacher's speech should be focused on the students in all situations and situations, such as when explaining the material, listening to the students' opinions, analyzing and reprimanding them. To

be a speaker, to be truthful in one's speech without using false words, that is, not to use words improperly in one's speech, is only to make one's speech beautiful. rather, it is necessary to enjoy the speech of the sages and learn from them.

Primary education is the first stage of the educational process, during which the child's abilities are realized, using all the possibilities. It is important to take into account the pedagogical, psychological and physiological characteristics and intellectual abilities of students in the speech of the primary school teacher. From the 1st grade onwards, the teacher's speech should be narrated with such skill that it stimulates students' thinking, interest and attention, and gives correct and clear answers to the questions asked. The teacher should use all the possibilities in his speech to develop the speech of the students, to overcome the shortcomings in it as a result of working with such students individually, without hasty conclusions even about children with some speech defects. Examples from life experience show that by practicing speech, its shortcomings are overcome. The great orator Demosthenes, for example, overcame his dumbness by practicing and became the great orator of ancient Greece.

Speech technique is one of the most important aspects of a teacher's speech. Many systems of exercises on speech techniques have been developed today, and every skilled teacher who has mastered this system can impart knowledge to the students through his speech and achieve the desired result. This requires a lot of attention and constant work from the teacher. The teacher sometimes has to speak at length during the explanation of the material. At this time, there is redness of the face, shortness of breath and a number of changes in the blood vessels. So breathing technique is one of the most important aspects of a teacher's speech.

When speaking and reading, you need to get more air, save it, and refresh it more often. Exhaling during speech breathing takes longer than taking in air.

Another important aspect of a teacher's speech is the uniqueness of the voice. We know that a person's voice can change over the years, and sometimes there are cases of voice distortion. There are several reasons for this. For example, sound stress can lead to sound distortion. In practice, this figure is as high as 50 percent in many areas, especially among teachers. Studies have shown that low-pitched explanations are more effective than high-pitched explanations. We can see in the views of our scholars that speaking out loud all the time always has negative consequences. For example, Abu Ali ibn Sina, in his Laws of Medicine, said: "Not paying attention to the voice leads to the loss of the voice, and the loss of the voice leads to the failure of the respiratory system. To do this, start reading aloud and gradually increase it after a while, but do not continue reading aloud for a long time", he wrote.

In addition, the teacher should pay attention to his / her own diction when speaking (Diction is the ability to pronounce the speaker clearly and intelligibly). Only then will every word and sentence of the teacher's speech be pronounced clearly.

Another key feature of teacher speech is that it is consistent with mimicry and pantomime. Mimicry is the expression of the emotional and mental state of one's mind. Sometimes a teacher's facial expressions and gestures are more powerful than what he or she is trying to say. Students learn what their teachers want to say from their facial expressions. Therefore, the teacher should be able to use facial expressions only for educational purposes and hide their personal experiences. Facial expressions are mainly represented by eyebrows, eyes and lips. It is through these details that the teacher expresses surprise, calmness, indifference, joy, eloquence, fear, and other psychological states. The most important thing is that in any case, the teacher's point of view should be with the students.

Pantomime is the movement of the body, arms and legs, and gestures. In this case, first of all, the teacher must know the aesthetics of posture during the lesson and be free from negative habits, namely: swaying back or forth, throwing weights from one leg to another, playing with hands unrelated to the lesson. It is not possible to scratch, clear the throat, dig out the ears or teeth.

In short, speech plays an important role in the professional development of an elementary school teacher. Such a teacher can be a good teacher only if his speech, pronunciation, diction, pantomime and mimicry are combined with it and he has a deep reserve of professional knowledge.

References:

1. Alisher Navoi Mahbub ul - kulub. - T.: Gafur Gulam Publishing House, 1993, p.79.
2. Abu Ali Ibn Sino. Laws of Medicine:.. Volume 1 -T.: A.Kodiriy, 1992, p.302.
3. Kaikovus "Nightmare", - Tashkent.: 2006, chapter 7, page 48.
4. Artikov A. Speech culture and public speaking. - T.: 2002.
5. The official telegram channel "For public educators".

*Shokhuzhaeva Z.S., candidate of economic sciences
associate professor*

*Department of Innovative economy
Karshi Engineering and Economics Institute
Republic of Uzbekistan, Karshi city*

*Donaeva F.B.
trainee researcher*

*Karshi Engineering and Economics Institute
Republic of Uzbekistan, Karshi city*

EFFECTIVENESS OF AGRARIAN AND ECONOMIC REFORMS IN AGRICULTURE OF UZBEKISTAN

Abstract: This article describes the process of agrarian reform in agriculture, its priorities, directions, the essence of the economic measures taken, the effectiveness of the results achieved in the implementation of reforms and proposals and recommendations to radically improve public policy to further deepen agrarian reform.

Keywords: agrarian reforms, modernization and diversification of the food industry, land reclamation, water-saving technologies, modern technologies, crop rotation system, innovative technologies.

Sustainable development of the country's economy, modernization of society, the development of democratic processes and, in many respects, the effectiveness of agriculture and reforms in it.

The deepening of reforms in the agricultural sector is reflected in the transition to and support of new forms of management, a number of measures to improve the living standards of the rural population. The main link in the ongoing reforms in the agricultural sector is property relations.

In a situation where real market relations prevail; the property right of every individual is a naturally necessary norm. Property law is the socio-economic basis of society, and this right is given to property owners. The first stage of economic reforms implemented by the Republic of Uzbekistan since independence has been devoted to property relations.

Reforms in agriculture can be divided into the following stages, (table 1).

Table 1

**STAGES OF ONGOING REFORMS IN THE AGRICULTURAL
SECTOR OF THE COUNTRY³⁴**

Stages	Naming of stages	Adopted laws	Achievements
Phase 1 (1990-1995)	The stage of creation of the legal basis of agrarian and economic relations in agriculture	“On Land”, “On Cooperatives”, “On Lease”, “On Farming”	The conditions have been created for the formation of a multi-sectoral economy
Phase 2 (1996-2000)	Reform phase in several areas of the agricultural sector	“On farming”, “On dehkan farm”	Deepening reforms in the market economy during this period The legal basis for this has been fully created
Phase 3 (2001-2008)	The stage of organization of agricultural production	“On Farming” (new edition), 2004 August 24	It paved the way for freedom of production and economic law in agriculture was given
Phase 4 (2009 to present)	Stage of innovative development of agricultural production	"On amendments and additions to the Tax Code of the Republic of Uzbekistan", December 30, 2019	Particular attention was paid to the creation of a complete cluster model and cooperation system, which would include an integrated chain of agribusiness.

The process of reforms in the village during the years of independence can be divided into four stages, depending on the priorities, directions, the nature of the economic measures taken.

The first phase of economic reforms – from the early years of the republic's independence until 1995.

This stage is characterized by ensuring the stabilization of agriculture in the country and the creation of the first foundations for the transition from a planned economy to a market economy.

The second phase of the reforms covered 1995-2000, this stage is characterized by the creation of an institutional framework for reform, a system of laws and regulations. An economic mechanism has been created to ensure the main goal of the reforms.

The third phase of reforms, including 2001-2008, is this phase:

- The priority of protection of the rights of agricultural producers;
- Expansion of economic freedom of agricultural producers and improvement of the pricing system for government products;

³⁴ Suggested by the author

- Commencement of reorganization of large agricultural enterprises, primarily low-profit and loss-making enterprises on the basis of transformation into farms;

- Construction of a system of infrastructure serving farms.

In the third stage of economic reforms, the process of transforming low-profit and loss-making companies into farms was organized.

In the fourth stage of the reforms in agriculture, that is, in the stage we are proposing, drastic changes have taken place.

- In 2008-2010, the optimization process was carried out and as a result, the size of farmland was optimized

- The area under cotton was halved (from 2 million to 1.2 million hectares), and the vacant area was allocated for food crops.

- Grain and food independence in general: grain production increased by 1 million tons between 1990 and 2016. and 8.2 mln. tonnaga. fruit and vegetable products 4 mln. 19 million tons tons;

- Per capita consumption of meat in 2016 compared to 1990 increased by 1.7 times (174.3%), milk - 2 times (201.2%), vegetables - more than 2 times (205.7%), fruits - 3, 6 times (359.5%) and potatoes - 5.2 times (519.3%);

- Fruit and vegetable processing has doubled in the last 5 years.

Also, the Action Strategy for the Development of the Republic of Uzbekistan for 2017-2021 identifies the following tasks on "Modernization and accelerated development of agriculture.":

- 1.3-fold increase in agricultural production, reducing its share in GDP from 17.5% to 13.5%;

- Increased crop yields in agriculture through the introduction of advanced agro-technologies, resource-saving methods, development of selection and seed systems. At the same time, increase the efficiency of mineral fertilizers by 15%, reduce water consumption by 12%;

- 1.5 times increase in fruit and vegetable production, 1.4 times increase in potato production, 1.3 times increase in melons and grapes;

- Improving the breeding work, strengthening the fodder base, increasing the number of breeding farms by 2.5 times, the area of fodder crops by 1.3 times as a result of modern technologies and modernization;

- 1.3 times increase in the number of livestock, 1.3 times in the production of meat and dairy products due to modern equipment of veterinary stations, improving the quality of services;

- Paying special attention to the development of poultry and fisheries, increase the number of poultry by 1.8 times and establish 670 fish farms;

- As part of measures to expand storage capacity and processing capacity of agricultural products, the production of canned fruits and vegetables by 1.7 times, canned meat by 2.2 times, sausage products by 1.8 times, dairy products by 1.1 times., Increase 9 times;

- Improvement of reclamation of 1.4 million hectares of land at the expense of projects for the construction, reconstruction and repair of reclamation facilities, installation of drip irrigation systems and the purchase of reclamation equipment at the expense of the Irrigated Land Reclamation Fund;

- Important strategic forecasting tasks have been identified, such as expansion of the fleet of agricultural machinery, their qualitative renewal, provision of farmers with effective agricultural machinery, improvement of service quality.

- This is primarily due to the rapid development of industrial industries and services in the economy of our country.

- Therefore, we believe that the following should be implemented as priorities for accelerating reforms in agriculture:

- Sustainable economic development and improvement of farms;
- Improving the reclamation of irrigated lands and the use of water-saving technologies in the use of water resources;
- Development of seed and selection work;
- Implement a livestock development program;
- Growing quality and competitive products in fruit and vegetable growing;
- Efficient use of land plots on farms;
- repair and modernization of processing enterprises.

However, we believe that the shortcomings and problems in the implementation of reforms in the agricultural sector are as follows:

- The science-based crop rotation system is not well established in the efficient use of agricultural land;

- Lack of development of natural and climatic conditions of the regions and corresponding varieties in the development of the plan of effective placement of agricultural crops;

- Lack of widespread introduction of innovative technologies in the efficient use of water resources;

- Incomplete fulfillment of contractual obligations in the enterprises of the procurement, service and supply system;

- Incomplete accounting on farms, economic relations between procurement and service organizations, etc.

As a result of the reforms, investment projects on construction, reconstruction and modernization of new processing plants equipped with the latest high-tech equipment for deep processing of agricultural products, production of semi-finished and finished food and packaging products have been implemented:

- infrastructure for storage, transportation and sale of agricultural products, agrochemicals, financial and other modern market services has been further expanded;

➤ to further improve the reclamation of irrigated lands, to develop a network of land reclamation and irrigation facilities, to introduce intensive methods of agricultural production, first of all, modern water and resource-saving agro-technologies, and to widely use high-yield agricultural machinery.

As a result of radical economic reforms and structural changes in the agricultural sector of the country, the main financial indicators of agriculture are growing steadily from year to year.

The analysis shows that the dynamics of the average annual stable growth rate of gross agricultural output for the past 2014-2016 was ensured. In particular, this figure was 105.4% in 2005 and 106.6% in 2016. The decline in the share of agricultural GDP in the country's GDP from 26.3% in 2005 to 17.7% in 2014 is positive.

However, by 2017, the growth rate of gross agricultural output was 102%, and in subsequent years, growth rates have not stabilized. Because the real data of the State Statistics Committee has been released to the public, and the indicators of the real results of the economy of the republic have become known. But even though agriculture did not achieve sustainable performance, it did not work at a loss. With a positive result, in 2018, the agricultural sector was joined by forestry and fisheries, and the final result, ie the gross output of agriculture, forestry and fisheries, began to be calculated. As a result, the share of the industry in GDP in 2018 was 47.9%, and in 2019 - 28.1%.

The Republic will lay the foundation for the development of agriculture through the modernization of agriculture, the introduction of structural changes and innovations, and will ensure the country's food security and competitiveness in production.

In recent years, great attention has been paid to increasing the volume of agricultural production, which is the mainstay of food security in the country.

In particular, extensive, well-thought-out work has been done to optimize the composition of arable land, the introduction of new and advanced technologies in production, the improvement of crop varieties and livestock breeds, the radical improvement of seed and selection work.

References:

1. Resolution of the President of the Republic of Uzbekistan No. 4486 "On measures to further improve the water resources management system." 09.10.2019
2. Analyzed on the basis of data from the Ministry of Water Resources of the Republic of Uzbekistan.
3. Decree of the President of the Republic of Uzbekistan No. PF-4947 "On the Action Strategy for the further development of the Republic of Uzbekistan". 07.02.2017.
4. Source: www.lex.uz.

5. Z.S.Shoxujaeva. Economic efficiency of water resources use in the agricultural sector. Monograph. T .: "Economy and Finance" Publishing House, 2012. 135 pages
6. Z.S.Shoxujaeva, A.B.Kurbonov. Sustainable Development Of The Agrarian Sector Depends On The Efficient Use Of Water Resources. International Journal of Engineering and Advanced Technology (IJEAT) ISSN: 2249 – 8958, Volume-8 Issue-6, August 2019.
7. Z.S.Shoxujaeva. Foreign experience in agriculture on the use of water resources. Economics Magazine # 1 (44), 2020 p. 19-23.
8. Z.S.Shoxujaeva. Prospects for agricultural development in the conditions of modernization of the economy. Monograph. Q .: Nasaf Publishing House, 2020. 200 pages.

ANALYZING THE REALITY OF THE TOURISM SECTOR IN SYRIA BETWEEN BEFORE AND DURING THE CRISIS (2011-2018)

Abstract: The concepts of political problems and the crisis appear to be inconsequential to the tourism industry, however a nearby assessment and examination of the meeting points and the impact on tourism reveals otherwise. The tourism sector in Syria of late confronted numerous challenges and difficulties during the crisis that ultimately led to the sector's deterioration due to terrorist acts. This research deals with an analysis of the reality of the tourism sector during the years of the crisis (2011-2018) and a comparison between this reality and the reality of the sector before the crisis. Research topics that arise from the available studies include the effects of crises and political instability on tourism demand, in addition to studying the impact of using tourism as a political tool, and the effects of political violence on tourist destinations. As well as discuss the administration's efforts to revitalize the affected tourist destinations. This research seeks to establish what is known about the relationship between crises and tourism, in addition to discussing terrorism as a tourism crisis. On the other hand, highlighting the characteristics of the tourism environment and the role of terrorism in reducing the benefits and gains that can be gained from the tourism industry, in addition to submitting proposals to manage the demand for tourist destinations during tourism crises.

Keywords: terrorism, political instability, Syrian crisis, international tourism, crisis management.

Introduction: After tourism has grown and the impact of the tourism sector has increased in the Syrian service economy, and after the rates of supply and demand and the contribution to the development of services and the national economy from 2003 to 2010 reached high levels [5, 6], the repercussions of the crisis began to affect the components of the Syrian economy, so that the tourism sector is the first sector affected by the crisis in a way. Direct, and for the return of this sector's activity to remain directly and chiefly dependent on the return of the security and safety factor, and the possibility of the return of investment in Syria. However, there are still many important questions that have not been answered enough, for example: How does the administration of the tourism sector manage the crisis of terrorism or political conflict? , What was the reality of the tourism sector in Syria

before the crisis, and how did this reality become after eight years of the crisis? What is the impact of the Syrian crisis on investment in the tourism sector, and on governmental spending on this sector? What is the impact of the crisis on the tourist facilities?

The effect of warfare on the vacationer environment. The interest of researchers and analysts in the components or elements of that environment has prompted the rise of the idea of frameworks where the travel industry association could be viewed as a framework whose assets are gotten from contributions from the general environment, to give them then again as yields as the travel industry and inn administrations. There may likewise be open doors for the association to acquire from the environment in which it works and the dangers or imperatives it might confront. This requires the requirement for pre-administration preparation and the advancement of fitting administration procedures and arrangements to manage them [1]. The tourism industry environment is affected by various ecological elements, for example, the serious climate, the economic climate, the world of politics, the regular habitat and the natural environment, the mechanical and technological environment, the examination of chances and dangers (analysis of opportunities and threats), and the social and cultural environment [3].

SWOT analysis of the tourism sector [4]:

▪ Analysis of the internal environment:

- **Strength point :**

- The rich and distinctive natural assets (geographical location, climate, rivers, lakes and desert, caves, nature reserves), which still characterize Syria despite the effects of the crisis on many of these areas.
- The human components and the great spread of Syrian folklore (singing and music).
- The rich and varied archaeological assets (castles, ancient cities, and religious shrines...).
- The great diversity in the products of traditional crafts and ancient industries.
- The regionally distinguished Syrian cuisine is a good attraction at the international level [5].
- The presence of many hotels with different levels covering a large area of Syria, in addition to restaurants and other tourism services, which are still able to cover all areas despite the damage that afflicted many establishments during the crisis [2].
- Adequate infrastructure from the road network, three airports (after the return of Aleppo airport), and ports that help attract tourism investment [5].
- Presence of public and private airlines, and many public and private banks.
- Graduating acceptable numbers from private tourist centers, hotels, and institutes of the Ministry to work in Tourist establishments [6].

- The spread of some free services for tourism, information centers and tourist police headquarters in most of Tourist areas.
- The conclusion of agreements and memoranda of understanding with a number of Arab and foreign countries and with some concerned parties in the sector, in addition to the agreements concluded before the crisis, according to which work was not canceled during the crisis [5].
- The existence of an acceptable level of standards regulating qualification, classification, licenses and tourism services (and they have been constantly amended to fit international standards, despite the crisis and its effects on the tourism sector).
- Simplifying the procedures followed to obtain a tourist building permit, which leads to encouraging tourism investment and accelerating work rates to shorten time and reduce the number of required documents [4].

Weaknesses Points:

The tourism sector in general in Syria suffers from weaknesses that extended before the crisis and exacerbated during the crisis, which were mainly:

- Weak domestic tourism as a result of high costs, especially accommodation costs compared to neighboring countries, which are mainly due to the low average per capita income in Syria. This problem has exacerbated during the crisis despite the constant attempts to provide a tourist product suitable for domestic tourism that the Ministry of Tourism has made over the years of the crisis [5].
- The low rate of tourism spending by Arab and foreign tourists in Syria, compared to neighboring countries due to poor services that meet the desires of tourists, in addition to the lack of basic services in tourist sites, especially archaeological ones. This point continued during the crisis and worsened, especially with regard to religious tourism areas (which It turned out to be the main and only tourism product during the crisis period) [6].
- Most of the tourism projects are concentrated in the major and main governorates as a result of the lack of resources and services needed to establish investment projects in promising tourist areas, especially the coastal and central areas [5].
- The previous focus of the promotion and marketing policies on the Western European markets and the neglect of the BRICS countries' markets, the effects of which were evident during the crisis period by the sharp decline in the number of tourists and the inability to compensate this number from other markets, especially the markets of friendly countries [5].
- Weakness in the content of promotional materials with regard to data, information on visa facilities and travel procedures, addresses of suppliers and producers of tourist trips, especially during the nation's period where we have

witnessed major changes and constant instructions and circulars that led to a loss of information for the tourist.

- Weakness in the participation of tourist NGOs, the local community and the private sector in promoting tourism [8].

- The absence of mechanisms to observe the customs and traditions of the visitor's behavior while in the country and the preservation of the environment, in addition to the absence of directives about military sites or points of contact and engagement, which made tourists lose a sense of security during the nation's period, even in somewhat recovering areas.

- Weakness in marketing products, crafts and traditional industries.

- Poor performance of tourism and travel offices in terms of organizing, promoting and marketing tourist trips internally and externally.

- The poor level of tourism services in the archaeological and religious sites and museums [5].

- Weakness in the technical and specialized professional level of graduates of tourism hotel schools and institutes, and in the level of training courses held, compared to the international level, especially a, there are many points in the tourism service that is an international language that must be mastered by the tourism service provider [7].

- Weakness in identifying priorities and obstacles to tourism development, and delays in issuing land acquisition plans.

- Delay in setting standards and standards for food, beverages and handicrafts.

- Delay in the completion of the electronic tourism geographic information system GIS.

- The absence of mechanisms that maintain the security of tourists and tourist health, the absence of entertainment and entertainment games, electronic reservation services, and mechanisms for accepting credit cards.

- The multiplicity of the supervisory authorities over the work of the tourism facilities, which results in duplication of the measures taken.

- Pollution of beach, rivers and lakes waters, which negatively affects tourism.

- Tampering and encroachment on archaeological sites by the local population, as a result of the lack of cultural, archaeological and tourist awareness, which increased dramatically during the crisis period, exposing many sites to systematic looting and destruction.

- Poaching, cutting and burning forests and natural reserves [6].

- Encroachment on the lands of the property of the Ministry, especially the coastal strip.

- The large and indiscriminate spread of unclassified furnished apartments in tourist areas, which increased during the crisis period.

- Central in preparing and implementing the Ministry's plans and promotional activities, and the weak participation of the relevant authorities in the tourism sector in their preparation [5].

- Internal environment analysis:

- **Opportunities** [4]:

- The return of stability, security and safety to all parts of the country.
- The presence of a large number of countries that have a positive image of Syria that helps to re-attract tourists from it.

- The international reputation of the name Syria (even in a negative form), which can be transformed into an opportunity by using sound scientific and promotional means.

- Encouraging religious tourism and giving it importance as a continuous tourism resource, taking advantage of the continuation of religious tourism despite the security conditions the country is going through.

- Enhancing the role of the private sector and the local community in developing and activating the tourism sector, and making use of the private sector to invest in hotel and tourism training and rehabilitation [5].

- The possibility of the return of global and international tourism management companies to manage tourism facilities owned by the private and public sectors.

- The cooperation of the concerned authorities in facilitating and simplifying the procedures for tourism investment through the creation of a single window.

- Expanding the tasks of the Syrian Company for Tourism as a developer in the tourism development areas [5].

- Take advantage of Syria's geographical location to link common and integrated tourist routes with some neighboring countries.

- Improving the participatory environment for the tourism sector through the cooperation of all parties related to the tourism sector and activating the principle of effective participation in the decision and implementation regarding the promotion of the tourism product (Cultural, environmental, religious).

- **Threats and challenges:**

- Fear of tourists and their reluctance to come to Syria as a result of the current situation.

- The disappearance of all tourist and archaeological sites and the inability to recover many of the archaeological collections that were lost in the crisis.

- The absence of real estate plans certified by the Ministry of Tourism, explaining on them in a detailed and accurate way the places (roadblocks, military zones, places of prevention of construction) and the most suitable areas for establishing investment projects.

- The Ministry's stop to participation in the activities, conferences and seminars of both Arab and foreign organizations, including the Arab Ministerial Council for Tourism, the World Tourism Organization, and the Organization of Islamic Cooperation has been suspended, which led to the failure to benefit from the financial and in-kind assistance provided by these organizations to finance tourism projects. It only participates in tourism activities, seminars and conferences organized by UNESCO.

- Suspending cooperation with a number of foreign agencies, including the French Development Agency, the European Commission, the United Nations Development Program, the Spanish Agency for International Cooperation, and the Japanese International Cooperation Agency, which provides assistance to the ministry in several areas.

- Large numbers of tourist establishments are out of service due to damage, financial or operational reasons, or because they are located in unsafe areas. More than 500 public and private tourist establishments have been damaged. Full or partial [2] [8].

- Delayed departure of stalled projects belonging to the private sector and B.O.T [5].

- The lack of necessary funding for the reconstruction of public and private sector facilities and tourist buildings.

- The absence of international management companies for hotel establishments in the country.

- The multiplicity of agencies involved in issuing tourism licenses, which exceed 15 entities and ministries [5].

- The multiplicity of agencies responsible for managing the tourism product (cultural tourism, ecotourism, religious tourism, river tourism, beach tourism, and cave tourism).

- The delayed issuance of the land use plan and regional planning plans, which affects the tourism planning for the development of tourism projects.

- The emigration of large numbers of hotel and professional tourism cadres with high experience abroad and a general weakness in the professional level of available labor and the instability of their situation.

- Some educational and training institutions have been out of service (Deir Ezzor Institute - Deir Ezzor High School - Raqqa High School - Idlib High School - Palmyra High School) and the major sabotage that many tourist educational institutions have been subjected to (Aleppo Institute - Aleppo High School - Homs High School - Hasaka High School - Daraa High School) [6].

Results of the previous analysis and study:

Comparison in terms of:	Before the crisis	During the crisis
Touristic product	The tourism product varied to include (cultural, entertainment, therapeutic, religious, environmental, adventure and safari, gastronomic ...).	The limitation of the tourism product, as a result of the crisis, to (mainly religious).
Tourism sector inputs	The inputs of the tourism sector at this stage were integrated, in terms of the requirements for establishing a tourism activity, despite its need for development, especially with regard to infrastructure, in order to provide a more mature tourism product for tourists, and to allow the sector to make the most of the tourism spending.	The inputs of the tourism sector have been affected greatly at this stage, especially with regard to the infrastructure that qualifies for the establishment of a tourism activity, in addition to the safety factor that is the basis for the tourism activity, the infrastructure has been subjected to systematic destruction of a method that weakened the capacity of the Syrian tourism product and tended in some stages to a complete disruption of tourism activity.
Tourism environment	The tourism environment at this stage was tending to be more stimulating and encouraging tourism investment, and significant and remarkable facilities were provided that led to a period of great prosperity for the tourism sector. Including Syria on the global tourism map and greatly increasing the demand for the Syrian tourism product.	Government interest in tourism decreased during this stage, as a result of the decrease in the contribution of tourism to the domestic product due to the effects of the crisis and insecurity on the Syrian tourism product, and despite several measures taken to reduce the effects of the crisis on the tourism sector, the lack of data and the absence of managing the tourism crisis scientifically led to a decline followed a very slow start of recovery during the studied phase.
Numbers of arrivals	The number of arrivals increased as a result of the previous points, and the increasing interest in the tourism sector nearly doubled between the beginning of the study in 2003 and until 2010, just before the crisis.	The decline in the numbers of arrivals in large proportions is closer to collapse, due to the effects of the crisis, in addition to the impact caused by what we talked about in the previous point in terms of weakness in the tourism crisis management experience, which led to the marginalization of the tourism sector, and that the great delay in numbers and statistics was a major cause of inability To plan in light of clear and instantaneous data.

<p>Strategies adopted at the total level (Ministry plan)</p>	<p>The strategies followed at this stage started from all the previous points, to work on developing a tourism product and tourism paths that fit the new trends of the tourism demand, and highlight the privacy of Syria and the diversity of its resources, and this strategy was based on accurate information about the trends of the tourism market, the behavior of tourists and tourist destinations, and taking advantage of all opportunities. In order to achieve the above, the strategy worked to secure an appropriate and attractive investment climate for tourism investments, to rehabilitate tourist attractions to suit both internal and external tourism, and a move was also directed to raise the level of tourism cadres by paying attention to tourism training and rehabilitation, and many other points, all of which contribute to the realization of the tourism plan. Scientific, studied and based on the availability of a robust and updated information structure in a continuous form commensurate with the information structure in that period.</p>	<p>The strategies followed during this period (despite its positiveness, awareness of the importance of tourism as an important and basic component of the Syrian economy, and its continuation of the approach that was followed before the crisis) were characterized as reactive strategies, so that the crisis has left clear effects on the tourism sector, And it led to its great retreat, and the departure of Syria from the global tourism map, and the management of the tourism sector during this period and despite its positive decisions that it tried to keep pace with these changes, lacked a plan for managing the crisis in a scientific way based on the literature on this topic, and on the experiences of countries that have gone through circumstances. Similar, and the main reason for the absence of this plan and being satisfied with the strategy of decisions taken in response to the effects of the crisis is the absence of accurate data related to the tourism sector, the delay in receiving these numbers to the ministry, and the delay in the ministry's implementation of the required statistics, to be in its best annual terms, which led to the inability to build A scientific plan based on accurate information and data that, if available, would have avoided many of the effects of the crisis on the tourism sector as a whole. It has tourist markets and new types of tourism, faster than what happened during this period already.</p>
---	---	---

References:

1. Hilal, Mohamed Abdel-Ghani Hassan, Skills of Crisis Management - The Crisis between Prevention and Control, Cairo, 2001. P.26.
2. ICROM, Preservation of Cultural Heritage in the Arab Region "In Issues of Preservation and Management of Heritage Sites." 1st floor, Sharjah, 2016.
3. Research, Documentation and Publishing Secretariat, Crisis Management from an Administrative Perspective, Sudan: The Higher Institute for Zakat Sciences, 2004. P.12.

4. Pearson. C. M. and Clair, J. A, Reframing Crisis Management; Academy of Management Review, 1998. P.11.
5. Interviews in the Syrian Ministry of Tourism, the Minister of Tourism, and the assistants of the Minister of Tourism, the Directorate of Planning and International Cooperation, the Legal Affairs Directorate, the Tourism Control and Quality Directorate, the Tourism Promotion Directorate, the General Authority for Tourism and Hotel Training, the Tourism Facilities Directorate, 2018-2019.
6. Syria, Syrian Statistical Group for the years 2003 - 2018, Central Bureau of Statistics.
7. The book of conditions for preparing the national electronic transactions system, published on the Ministry of Communications and Technology website.
8. WTO World Trade Organization. (1999). Impacts of the Financial Crisis on Asia's Tourism Sector. Madrid

*Sodiqova G.G'.
2-bosqich magistranti
(boshlang'ich ta'lim)*

FarDU Ta'limva tarbiya nazariyasi va metodikasi

**BOSHLANG'ICH SINIF O'QUVCHILARINING MUSTAQIL O'QISH
KO'NIKMALARINI SHAKLLANTIRISH METODIKASI
METHODOLOGY OF INDEPENDENT READING SKILLS FOR
PRIMARY SCHOOL STUDENTS**

Annatsiya. Maqolada o'quvchilarni o'qish malakasi bilan qurollantirish bilan bir qatorda kitobni mustaqil o'qiy oladigan, uni tushunadigan, ma'lum bir mavzuga oid kitoblarni tanlay oladigan, gazeta va jurnallarni ham mustaqil o'qiydigan faol kitobxonni tarbiyalash haqida fikrlar keltirilgan.

Kalit so'z. Sinfdan tashqari o'qish, o'qish malakasi, faol kitobxon, badiiy kitob.

Maktab o'quvchini o'qish malakasi bilan qurollantirish bilan bir qatorda kitobni mustaqil o'qiy oladigan, uni tushunadigan, ma'lum bir mavzuga oid kitoblarni tanlay oladigan, gazeta va jurnallarni ham mustaqil o'qiydigan faol kitobxonni tarbiyalaydi. Shu jihatdan sinfdan tashqari o'qish (STO) tarbiyaning asosiy quroli sifatida xizmat qiladi, ko'p narsani bilishga havasni orttiradi. STO'ning maqsadi o'qish malakalarini takomillashtirish, kitob tanlay oladigan, muntazam kitob o'qiydigan, o'qilgan kitobni to'g'ri baholay oladigan ongli kitobxonni tarbiyalashdir.

Maktablarda 1959-yildan boshlab maxsus STO' darslari tashkil etilgan. STO' darslari 1-2 - sinfda haftada 1 marta, 3-4-sinfda 2 haftada 1 marta o'tkaziladi. Savod o'rgatish jarayonida esa haftadagi oxirgi alifbe darsining 17 - 20 daqiqasi ajratiladi.

Sinfdan tashqari o'qish o'quv dasturi bilan chambarchas bog'liq bo'lib, unda ko'zda tutilgan maqsad va vazifalarni amalga oshirishda yaqindan yordam beradi. Buning uchun o'quvchilarda kitobxonlik madaniyatini tarbiyalash, ularni oddiy kitobxondan ijodkor kitobxon darajasiga ko'tarish talab etiladi. O'quvchilarda kitobga havas uyg'otishda har bir bolaga yakka tartibda yondashish, shaxsiy qiziqishlarini hisobga olish za'ir. Bolalarda kitob ustida ishlash malakasini shakllantirish ularni kitobxonlik madaniyatini tarbiyalashning muhim omilidir. Bunda o'qish uchun ajratilgan soatlardan foydalaniladi. Badiiy va ilmiy-ommabop asarlar mustaqil ravishda va izchil o'qib borilsagina, o'quvchilarning dunyoqarashini shakllantirish va kengaytirishga xizmat qiladi. Sinfdan tashqari o'qish tanish bo'lmagan mualliflarning kitoblari muqovasi, titul varag'i, kirish so'zi, mundarijasi va

suratlariga qarab asarning taxminiy mazmunini aniqlashga o'rgatish vazifasini amalga oshirishga xizmat qiladi.

Sinfdan tashqari o'qish darslarining asosiy vazifasi o'quvchida badiiy kitoblarni o'qishga havas uyg'otish, o'qigan kitoblari yuzasidan kundalik yurita olishga o'rgatish, bolalar adabiyotining mashhur adiblari hayoti va ijodi bilan elementar tarzda tanishtirish hisoblanadi.

Bolalarda ezgulikka muhabbat, yovuzlikka nafrat uyg'otish, ularning bog'lanishli nutqini o'stirish, adabiy-estetik tafakkurini yuksaltirish sinfdan tashqari o'qish darslarining ham tub mohiyatini tashkil etadi.

STO' darslarining muhim vazifalaridan biri mustaqil o'qish malakalarini tarbiyalash hisoblanadi. Buning uchun mustaqil bajarish uchun topshiriqlar berish, qiziqarli mashq turlaridan foydalanish, eng yaxshi insholarni, taqrizlarni, yozuvchi haqida to'plangan ma'lumotlarni o'qitish, „Tez aytish „ Topishmoqlar topish“, „If odali o'qish“, „Maqollar aytish musobaqasi“, „Ertak to'qish“, „Bilimdonlar anjumani* kabi ko'rik-tanlovlar tashkil qilish, muayyan mavzular bo'yicha savol-javoblar uyushtirish, o'yin tarzidagi ish turlaridan foydalanish zarur. O'qilgan asarlar yuzasidan suhbatlar o'tkazish, „Kitob haftaligi“ tashkil etish, asarlar asosida kichik insholar yozishni mashq qilish yaxshi samara beradi. STO' sinfda o'qish bilan uzviy bog'liq ravishda uyushtiriladi.

Sinfdan o'qish STO' uchun zarur bo'lgan o'qish malakalarini shakllantiradi, o'quvchilarning o'qigan asarini tushunishga o'rgatadi, lug'atini boyitadi. STO' qiziqarli va o'ziga jalb etadigan faoliyat bo'lib, bolalarning bilim doirasini boyitadi, qiyoslash uchun material beradi. Sinfdan o'qish — hayotga tayyorlash vositasi, sinfdan tashqari o'qish esa hayotning o'zidir. Hozirgi paytda boshlang'ich sinf o'quvchilari uchun sinfdan tashqari o'qishga mo'ljallangan „Kitobim - oftobim“ (1—3-sinflar uchun) nomli qo'llanmalar ham chop etilgan. Sinfdan tashqari o'qish bosqichlari STO' darslari o'quvchilarda mustaqil kitob tanlash va o'qish malakalarini shakllantiradi. Mustaqil o'qish malakasini shakllantirish

3-bosqichga bo'linadi:

1. Tayyorlov bosqichi. Bu 1-sinfning savod o'rgatish davriga to'g'ri keladi. Unga darsning bir qismi — 17—20 daqiqasi ajratilgani uchun „STO' mashg'uloti“ deb yuritiladi. U ning o'ziga xos xususiyatlari shundaki, o'qituvchi asarni o'zi tanlaydi, asarning kichik hajmda bo'lishiga va boshqa kitob tanlash tamoyillariga e'tibor beradi. Asarni o'qituvchining o'zi o'qib beradi. O'quvchilar asarni eshitishga, eshitganlarini idrok etishga, ularga soddagina baho berishga, asar mazmuni bilan sarlavhasining mosligini aniqlashga, asar mazmunini hikoya qilib berishga o'rgatiladi. Bu bosqichda o'quvchilar o'qish gigiyenasi va kitobga qanday munosabatda bo'lish bilan tanishadilar.

2. Boshlang'ich bosqich. Bu 1-sinfning 2-yarim yilligiga to'g'ri keladi. Bu bosqichda haftada 1 marta 45 daqiqalik dars uyushtiriladi. Asarni

o'qishdan oldin o'quvchilar asar nomi va uning muallifi bilan tanishadilar, rasmlarini tomosha qiladilar, daftarlariga u haqda soddagina qilib asar muallifini va nomini yozadilar. Asar elementar tarzda tahlil qilinadi. Tanlangan asar (kitob) yaxshi o'qiydigan o'quvchiga maxsus tayyorgarlikdan so'ng o'qitiladi. Asarning oson o'qiladigan o'rinlarini bo'sh o'qiydigan o'quvchilarga o'qitish ham mumkin. Bu ularda o'qishga qiziqish uyg'otadi. Bu bosqichda o'quvchilar har xil tezlikda bo'g'inlab o'qiydilar. Shuning uchun o'qituvchi bu jarayonda har bir o'quvchiga individual yondashishi, kichik kitobxonni kitobni mustaqil o'qishga o'rgata borishi lozim.

3. Asosiy bosqich. Bu bosqich 2—4-sinflarga to'g'ri keladi. Bu davrda o'quvchilarning o'qish malakalari mustahkamlanadi. Bunda o'quvchilarning sinfdan tashqari o'qiganlari baholanadi. Baholashda dastur talablariga asoslaniladi: o'qigan kitoblarining sifat o'zlashtirishiga, miqdoriga, o'qigan kitobga munosabat bildirilishiga e'tibor beriladi. Bunda o'quvchilar muayyan mavzuga doir bir necha asarlarni o'qib keladilar, ularning ayrim o'rinlarini ifodali o'qib beradilar, o'qigan asarlarini o'zaro taqqoslaydilar.

STO'ning bosqichlari, dastur talablari, tarbiyaviy vazifalari o'quvchilarning qiziqishlari bilan belgilanadi. Masalan, tayyorlov bosqichida kichik hajmdagi asarni o'qituvchi o'qib bersa, o'qilganlar yuzasidan suhbat, qayta hikoyalash o'tkazilsa, boshlang'ich bosqichda butun sinf o'quvchilari bir xil kitob bilan ta'minlanadi, barcha o'quvchilar bitta matn ustida ishlaydilar. Bunda bitta yozuvchi yoki bir mavzudagi asarlar ko'rgazmasi tashkil qilinadi. Asar ichda o'qishga topshirilishi, albomlar tayyorlanishi, kinofilm va diafilmlardan parchalar ko'rsatilishi, musiqiy daqiqalar o'tkazilishi hamda asar mazmuni yuzasidan ijodiy rasmlar chizdirilishi ham mumkin. Bu jarayonda kitobni saqlash maqsadida uni o'rash o'rgatiladi, „Ertaklar bayrami, Ifodali o'qish tanlovi“ o'tkaziladi.

Asosiy bosqich yakunida kichik yoshdagi o'quvchilar faol kitobxon uchun zarur bo'lgan yaxshi o'qish ko'nikma va malakalarini egallashlari, eng muhimi, ularning kitob hamda mustaqil o'qishni yaxshi ko'rishlariga erishish juda muhimdir.

Sinfdan tashqari o'qish uchun kitob tanlash tamoyillari metodikaning vazifalaridan biri STO' uchun kitoblar tanlash, o'qiladigan adabiyotlar ro'yxatini tavsiya qilish, yillik o'quv rejasi va dars tuzilishi namunalari ishlab chiqishdir.

Kitobni targ'ib qilish. STO'ga tavsiya qilinadigan asarlar ro'yxati sinfga yoki maktabning maxsus joyiga osib qo'yiladi, ular vaqtivaqti bilan yangilab turiladi, to'ldiriladi, ko'rgazmalar tashkil qilinadi. O'qituvchi maxsus suhbatlar uyushtiradi.

2. Yakka tartibdagi yordam va kundalik tekshiruv. O'quvchilarning o'qigan kitoblari yuzasidan suhbat uyushtiriladi, o'qilgan kitoblar hisobga olinadi. Shaxsiy fikrlar aniqlanadi, uy kutubxonalari bilan tanishiladi, ota-onalar bilan suhbat o'tkaziladi.

3. STO‘ yuzasidan ommaviy ishlar. Adabiy ertaklar, viktorinalar, yozuvchilar bilan uchrashuvlar, adabiy ekskursiyalar uyushtiriladi, ular uchun maxsus tayyorgarlik ko‘riladi.

4. Kutubxonaga yozilish. 1-sinf o‘quvchilari o‘qituvchining tavsiyasi bilan kutubxonaga a‘zo bo‘ladi. Bu jarayonda o‘qituvchi va kutubxonachi hamkorlikda ish olib borishi maqsadga muvofiq bo‘ladi.

5. O‘quvchilarning o‘qiganlarini hisobga olish. Bunda ularning kitobxonlik kundaligidan foydalaniladi. 1-sinf o‘quvchilari 2-yarim yillikdan boshlab kitobxonlik kundaligiga yozuvchining ismi, familiyasi va kitob nomini, 2-sinfda esa unga nashr etilgan joyi va yilini qo‘shib yozadilar. 3—4-sinflarda o‘qigan kitobning qisqacha mazmunini yozib, unga taqriz va o‘z mulohazalarini ham qo‘shishlari mumkin. O‘quvchilarning o‘qigan kitoblari og‘zaki tarzda ham hisobga olinadi: ular o‘qiganlari yuzasidan sinfdan tashqari o‘qish va sinfdan o‘qish darslarida, yakka tartibdagi suhbatlarda gapirib beradilar.

Foydalanilgan adabiyotlar:

1. O‘zbekiston Respublikasi Prezidentining “O‘zbekiston Respublikasini yanada rivojlantirish bo‘yicha Harakatlar strategiyasi to‘g‘risida “gi Farmoni.-T:Xalq so‘zi,2017-yil 8-fevral
2. Safo Matjonov,Xolida G‘ulomova, Sharofat Yo‘ldosheva ,Sharofjon Sariyev”.Ona tili o‘qitish metodikasi”.Toshkent.”Nosir”nashriyoti 2009.
3. Ishmuxamedov R.J., Yuldashev M. Ta’lim va tarbiyada innovatsion pedagogik texnologiyalar.– T.: “Nihol” nashriyoti, 2013, 2016.–279b.
4. Sayidahmedov N.S. Yangi pedagogik texnologiyalar. – T.: Moliya, 2003. – 172 b.
5. S.Matjononov, X.G‘ulomova,Sh. Sariyev Z.Dolimov. O‘qish kitobi. 4-sinf uchun darslik.Qayta ishlangan va to‘ldirilga 6-nashri.

ENSURING FINANCIAL SUSTAINABILITY OF FARMS IN UZBEKISTAN

Abstract. The article focuses on ensuring the financial sustainability of farms in Uzbekistan through the efficient use and management of financial resources. Today, the farms operating in Uzbekistan are engaged not only in the production of agricultural products but also in the storage, processing, and packaging of agricultural and livestock products, as well as in the supply and demand of consumers in rural areas. It should be noted that the provision of services further increases the financial stability of the economy. One of the important tasks facing farms in the current situation is to form an optimal amount of current assets.

Key words: Financial analysis, financial stability, financial indicators, financial resources, economic competence of farms, Uzbekistan

Introduction. In a known market economy, farms tend to use the limited resources available. This is because of the slight negligence of farms in such conditions can lead to the loss of financial resources. Efficient use and management of financial resources on farms is one of the most important tasks today.

The third priority of the Action Strategy for the five priority areas of development of the Republic of Uzbekistan in 2017-2021 is called "Priorities for economic development and liberalization", which includes the development of financial and lending standards. [1].

The broad introduction of market relations in Uzbekistan and radical improvement of mechanisms of financing and mutual settlements in agriculture, on this basis, to improve the financial and economic condition of agricultural producers and their service structures, increase profitability, ensure sustainable growth of production, diversify production. The emphasis on development has made the issue of improving working capital management one of the most pressing issues [2].

The urgency of this problem is primarily since the development of production on farms should be based on market demand, not on the state order. This is because the main requirement of the Uzbek government is that farms should be able to generate additional funds or income through diversification - the development of new production sectors. The income should serve to ensure the financial sustainability of farms. Financial stability, on the other hand, requires

the formation of a new structure of working capital and its management based on the principles of a modern market economy. This is a new problem for many farms operating in the country, and failure to study it promptly will lead to the bankruptcy of financial enterprises and their financial incapacity. Therefore, the study of this problem and the development of scientifically based recommendations and conclusions on it is one of the current research topics of scientific and practical importance today.

As a result of the development of the farming leaning, more than 160,000 farms have been formed in the country in recent years, and today they are effectively operating in more than 10 areas. The most gratifying thing is that more than 12,000 heads of farms are under 30 years old, and more than 6,000 farms are headed by women. Multi-sector farms have increased by 45 percent in the last two years, bringing their number to 75,000 today. Only because of this, hundreds of thousands of new jobs have been created in places, in remote villages. As a result of economic reforms and the development of the farming movement, 8,377,000 tons of grain have been grown in the country this year. [3]

The Land Code, the Law "On Farming", the Decree of the President of the Republic of Uzbekistan dated October 27, 2003 "On the Concept of Farm Development in 2004-2006", the Law "On Farming in Uzbekistan" Decree of the President of the Republic of Uzbekistan dated February 28, 2018 No PP-3575 "On arrangements to radically improve the system of financing the cultivation of raw cotton and grain" and many other legislative acts were adopted [2].

Financial privileges and facilities are provided to enterprises operating in the agricultural sector. As a result, the position of these enterprises in the production of agricultural products is maintained at a reasonable level, and favorable conditions are created to ensure financial stability [4].

Research methodology. The development of diversified production opens up opportunities for farms to use working capital. However, the financing of new types of production and ensuring its efficiency requires farm managers to develop its normative levels based on the forecast of future profits, depending on the level of productivity of factors of production. At the same time, taking into account the fact that the normative levels adopted in science, ie the coefficients are adapted to the activities of industrial enterprises, require farms to study based on the characteristics of crops or industries.

Today, the farms operating in Uzbekistan are engaged not only in the production of agricultural products but also in the storage, processing, and packaging of agricultural and livestock products, as well as in the supply and demand of consumers in rural areas. It should be noted that the provision of services further increases the financial stability of the economy. One of the important tasks facing farms in the current situation is to form an optimal amount of current assets. Farms are highly dependent on climatic and environmental conditions, and they must be provided with current assets and use them effectively. Because the implementation of agro-technical measures, delays in the

cultivation and sale of products is directly related to the organization of working capital, planning, and financing, as well as the provision of farm management with accounting data.

The financial condition of business entities is a complex concept that reflects the interconnectedness of all elements of the financial relations that arise in the course of its economic and commercial activities. The financial condition of business entities is characterized by the sources of placement and use of funds and their formation. To determine the financial position, a financial analysis is conducted, which includes:

- express analysis of financial condition (analysis of the structure of assets and liabilities, the state of property, reserves and expenses);
- financial stability analysis;
- analysis of financial results of activities;
- analysis of profitability and business activity.

The financial condition of business entities is also characterized by a set of indicators that reflect the process of formation and use of national resources. The results of financial and economic activities are not only in the focus of attention of business entities, workers and employees, but also in the spotlight of its business partners, the state, financial, tax authorities and others. All this increases the importance of conducting an analysis of the financial condition of business entities and its importance in economic processes.

The purposes of financial analysis are:

- identification of changes in a financial position as well as factors affecting sustainability;
- assessment of qualitative and quantitative changes in the financial situation;
- assessment of the financial condition of business entities for a particular item;
- identification of the main directions of changes in the financial situation and others.

The analysis of the financial condition determines and evaluates the profitability of the product sold by business entities, its working capital, financial stability, balance sheet liquidity, solvency and creditworthiness.

Ensuring the financial stability of the enterprise is of particular importance in determining the economic parameters of the enterprise, including financial parameters (indicators), their analysis. To do this, it is necessary to use a system of indicators.

Financial stability and its provision first, describes not only the capital structure of individual farms but also the financial condition of farms as a whole;

- Secondly, it is a complex indicator of the activity of farms, based on the profitability and repayment of debts, the ability of farms to finance their activities, and the rapid development of resource turnover;

- Thirdly, it reflects the results of production and financial activities of farms and reflects the systemic process of harmonization of these results, taking into account the feedback between them;

-Fourth, it provides the highest return on investment through the management of the working capital of farms.

From the approaches to financial stability and its provision and assessment in the economic literature, it can be concluded that the financial justification of financial stability and its provision and the classification of its indicators requires an approach based on the specific characteristics and specialization of the object. Based on the specific characteristics of farms, it is expedient to classify financial stability and its provision into absolute and relative indicators (financial ratios).

It is expedient to interpret the system of absolute indicators of financial stability and its provision as a surplus or shortage of sources of funds that form reserves and costs, which arise in the form of the difference between the volume of reserves and expenditures.

In order to provide a broader picture of the financial condition of farms, in addition to the absolute indicators to assess the financial stability of farms and its security: absolute liquidity ratio; solvency ratio (current liquidity); financial independence ratio; own and borrowed capital ratio; own working capital ratio; turnover ratio of receivables; turnover ratio of accounts payable; balance sheet profit margin ratio; it should be limited to coefficients such as the net profit margin.

Through the above-mentioned absolute and relative indicators of financial stability and its provision, it is possible to rationally assess the financial stability of farms, which play an important role in ensuring the financial stability of farms, developing and implementing organizational and economic mechanisms.

Conclusions. Based on the above, it should be noted that today in Uzbekistan in ensuring the financial stability of farms it is necessary to increase the level of use of fixed and circulating assets and their economic efficiency, as well as the effective use of an appropriate system of indicators. At present, the level of use of fixed and circulating assets, their efficiency does not fully meet the demand. Because farms with low levels of fixed assets are not fully provided with them, incentives for their use are weak. To increase the level and efficiency of their use, it is necessary to provide farms with such tools in full and in proportion, to increase the serviceability of fixed assets, to use them wisely throughout the year, to improve financial incentives, to develop their market.

References:

1. Decree of the President of the Republic of Uzbekistan PF-4947 "On the strategy of further development of the Republic of Uzbekistan". February 7, 2017.
2. Resolution of the President of the Republic of Uzbekistan No. PP-3574 of February 28, 2018 "On measures to radically improve the system of financing the production of raw cotton and grain."

3. Resolution of the President of the Republic of Uzbekistan No. PP-149 of February 28, 2018 "On measures for the widespread introduction of market mechanisms in agriculture."
4. Speech of the President of the Republic of Uzbekistan "The results of the main work done in 2017, which is a new stage of our development, and the priorities of socio-economic development of the Republic of Uzbekistan in 2018" dated 22.12.2017.
5. Nafisa Tadjibaeva. Ensuring financial stability of farms on the basis of effective working capital management. Master's thesis on specialty "Management in agriculture". Andijan, 2018.
6. Б.Носиров, Н.Сафина. Роль инноваций в устойчивом развитии фермерских хозяйств. Молодой ученый. Международный научный журнал. №18 (152), май 2017, часть II. стр. 164-166. ISSN 2072-0297.
7. O.Shermatov, B.Nosirov, R.Imomov, M.Qobulova. Problems of effective usage of lands in agriculture for ensuring food security. South Asian Journal of Marketing & Management research, 10 (4), p. 71-76. ISSN: 2249-877X.
8. U.Sangirova, B.Nosirov, B.Rakhmonova. Properties and potential of walnut growing in Uzbekistan. JournalNX - A Multidisciplinary Peer Reviewed Journal, ISSN: 2581-4230, Volume 6, Issue 5, Page No. 140-146. <https://journalnx.com/papers/20150963-potential-of-walnut.pdf>.

*Turdimambetov I.R., Doctor of Science in Geography
Associate Professor
Karakalpak State University named after Berdakh
Uzaqbaev Q.K., Doctoral Candidate
Nukus State Pedagogical Institute named after Ajiniyaz
Oteuliev M.O., Doctoral Candidate
Karakalpak State University named after Berdakh*

TERRITORIAL FORMATION OF THE EDUCATION SYSTEM IN IMPROVING THE QUALITY OF LIFE OF THE POPULATION OF THE REPUBLIC OF KARAKALPAKSTAN

Annotation: This article analyzes the problems of geographical location of kindergartens and schools, their coverage of kindergarteners and schoolchildren, and gives some recommendations for their improvement.

Keywords: services, educational institutions, education, kindergarten, school, mile

Introduction. The education system, which is one of the spheres of public services, is the basis of the development of any state. Because the highly classified labor force that drives the economy emerges as a result of the education system. In the history of the world or today, the countries with the strongest education system are the most developed countries in the world. Supporting “smart” people with strong innovative abilities, who have widely implemented innovations in the education system, is the basis for the comprehensive development of these countries. We can see that the education system in the developed countries of the world is different from other countries, the priority of science, along with theory, is that practice is very well organized.

President address to the Oliy Majlis of the Republic of Uzbekistan on January 24, 2020, he said, "First of all, science and high spirituality are needed to raise the level of knowledge, not only of our youth, but of all members of society. Where there is no knowledge, there will be backwardness, ignorance and, of course, misguidance" [1].

As a result of the President's special attention to the education system, great tasks and the accumulated problems are being solved in this section.

The location, development of organizations of the education system and the study of their territorial differences are studied in the Geography of education and the Geography of services, which is a branch of Socio-economic Geography. If there is an education system in any region or area, its subject is the education system in that area, i.e. pre-school education, general secondary education institutions, and secondary special, professional education. Activities of

educational institutions, postgraduate education institutions, retraining and professional development organizations and the number of students in them, the regional specificity of the number of out-of-school students are description of their peculiarities [4].

Education is the main branch of social services to the population. This system in our country: pre-school education (kindergartens), general secondary education (general secondary schools), secondary special, professional education (academic lyceums, professional colleges, technical schools near higher educational institutions), higher education (Higher Education Institutions), postgraduate education, retraining and professional development and out-of-school education systems.

Materials. Preschool education institutions are the beginning of the education system, which plays an important role in the educational upbringing of children. There are 809 kindergartens in the Republic of Karakalpakstan, of which 419 are located in cities and 390 in rural areas [5]. The capacity of kindergartens to receive children is 68,651 children, and today 94,826 children are upbringing education. That is, 26,175 children were placed in additional rounds due to lack of places in kindergartens. The admission of kindergartens in cities is 35,698 children, in which 58,758 children are accepted, the level of involvement of kindergartens is 164.6%. The number of children admitted to kindergartens in the villages is 32953 children, in which 36068 children are placed or the level of involvement of kindergartens is 109.4%.

Table 1

Preschool education system

Name	Total	Hence,	
		In the city	In the village
The total number of preschool education institutions	809	419	390
- child acceptance capacity	68651	35698	32953
- number of the upbringing children	94826	58758	36068
- number of coverage by capacity, %	138,1	164,6	109,4
- number of foster children	4333	2632	1701
hence non-state kindergartens	411	197	214
- child acceptance capacity	14441	7617	6824
- number of the upbringing children	13294	7009	6285
- number of coverage by capacity, %	92,1	92,0	92,1
- number of foster children	534		
Preschool children aged 3-6	155561	73267	82294
Involvement of children in preschool educational institutions (%)	61,0	80,2	43,8

Results and discussion. In terms of districts, the number of children aged 3 to 6 in Nukus is 23032. There are 19,203 children in 12,950 places in 99 kindergartens in the city. Kindergarten enrollment in the city is the second highest in the country after Muynak district.

It is known that large service areas are located in densely populated areas. The system is of high quality, high level of service and everyone uses the services provided to the population in an orderly manner. Their impact force is expressed in terms of service radius and is calculated using the following formula:

$$R^{Sr} = \frac{\sqrt{A^{Sr}}}{n} \times 1000$$

Here: R^{Sr} - service radius;

A^{Sr} - a certain type of service area;

n - the number of service providers of a particular type;

The rate of transition per meter per 1,000 kilometers [3].

The geographical location of kindergartens in district centers or villages differs from that in kindergartens in Nukus. For example, the area of Nukus is 220 km², the number of kindergartens is 99. These indicators can be used to determine the average service radius of kindergartens. To calculate this, we use the following formula:

$$R^{Sr} = \frac{\sqrt{A^{Sr}}}{n} = \frac{\sqrt{220}}{99} = \frac{14,8}{99} \approx 0,15 \times 1000 = 150$$

In Nukus, the average service radius of each kindergarten is 150 meters or 0.15 kilometers. This is a relative average, and the population density in the Nukus Mahalla Citizens' Assemblies varies.

According to this indicator, Nukus district has an area of 940 km² and 29 kindergartens.

$$R^{Sr} = \frac{\sqrt{A^{Sr}}}{n} = \frac{\sqrt{940}}{29} = \frac{30,6}{29} \approx 1,06 \times 1000 = 1060$$

The average service radius of each kindergarten in Nukus district is 1060 meters or 1.06 kilometers. This indicator may decrease in Akmangit village, the center of the district, and increase in Kerder, Kutankol, Tok tau Rural Citizens' Assemblies.

There are currently 344,042 school-age pupils in the Republic of Karakalpakstan, who are fully covered by education. There are 725 general secondary schools, 22 music schools, 22 children's and youth sports schools in the country. There are 197 general secondary schools, 20 music schools, 22 children's and youth sports schools in the cities, and 528 general secondary schools and 2 music schools in the villages. There are no sports schools for children and adolescents in rural areas. This prevents rural children from joining sports and music sections. Attending in cities sports schools or music sections can make it difficult to go long distances, live, and so on.

There are currently 9 HEIs in the Republic of Karakalpakstan, including Karakalpak State University named after Berdakh and Nukus State Pedagogical Institute named after Ajiniyaz, with 28,451 bachelors and masters student. The capacity of these higher education institutions is 17124, and 11327 students need additional classrooms.

Conclusion. Based on the above, there are shortcomings in the geographical location of education in the Republic of Karakalpakstan. In order to eliminate them, it is necessary to work in accordance with international norms. For example, if kindergartens and schools are built due to the high population density in the cities, it is advisable to establish small kindergartens and schools due to the low population density in the villages and the long distance between the villages. It is clear that the establishment of music schools, sports schools for children and adolescents in rural areas will create opportunities for future world champions and world-renowned musicians in these villages.

References:

1. Address of the President of the Republic of Uzbekistan to the Oliy Majlis (in Uzbek)
2. Komilova N.Q., Jumaxanov Sh.Z., Mirzaaxmedov X.S., Toshpo'latov A.M. Sotsial va madaniy geografiya. – T.: O'zMU, 2019. – 246 p.
3. Nazarov M., Tojiev Z. Ijtimoiy geografiya. – T: 2003.
4. Қарақалпақстан Республикасының экономикалық-социаллық раўажланыўының тийкарғы көрсеткишлери. Nukus, 2020.
5. Ballieva R., Oteuliev M. Peculiarities of the ethnotourism development in the Republic of Karakalpakstan. Materials International Scientific and Practical Conference. Protection and Rational Use of Natural Resources of the South Aral Sea Region. Pp. 206-210

Turopova L.S.
senior teacher
Karshi State University
Ismoilova M.K.
teacher
Karshi State University

TEACHING GRAMMAR CREATIVELY AT ELEMENTARY LEVEL

Annotation: After independence of the Republic of Uzbekistan all spheres of life has been developed swiftly. Teaching grammar methods has also enhanced interests of researches and common people in a great extent. The translation, being one of the most important means of interlingua communication, is indispensable in the process of integration to the world community at all levels. In global life people always have interests to other communities' worldview. The deep penetration to cultural heritage of any country cannot exist without clear understanding of works of literature.

Key words: grammar, level, learn, text, language, remember, teacher, term.

English level A1 is the first level of English in the Common European Framework of Reference (CEFR), a definition of different language levels written by the Council of Europe. In everyday speech, this level would be called “beginner”, and indeed, that is the official level descriptor in the CEFR, also used by EF SET. In practice it is possible to be at a pre-A1 level of English. A student who is just beginning to learn English, or who has no prior knowledge of English, is at a pre-A1 level.

An A1 level of English would be sufficient for very simple interactions, for example as a tourist in an English-speaking country. An A1 level would not be sufficient for other academic or professional purposes.

According to the official CEFR guidelines, someone at the A1 level in English:

Can understand and use familiar everyday expressions and very basic phrases aimed at the satisfaction of needs of a concrete type.

Can introduce herself and others and can ask and answer questions about personal details such as where she lives, people she knows, and things she has.

Can interact with other people in a simple way provided the other person talks slowly and clearly and is prepared to help.

The Common European Framework of Reference for Languages (CEF or CEFR) was put together by the Council of Europe as a way of standardising the levels of language exams in different regions. It is very widely used internationally and all important exams are mapped to the CEFR.

There are six levels: A1, A2, B1, B2, C1, C2. These are described in the table below.

CEFR English levels are used by all modern English language books and English language schools. It is recommended to use CEFR levels in job resumes (curriculum vitae, CV, Europass CV) and other English levels references. We list here the CEFR descriptors for language proficiency level with the approximate equivalent to other global English evaluation schemes- Cambridge ESOL, Canadian Language Benchmarks / Canadian English Language Proficiency Index Program (CLB/CELP), Canadian Academic English Language Assessment (CAEL), BULATS, IELTS and TOEFL.³⁵

English language levels description:

English Basic User (A1, A2)

A1 (Beginner)

A2 (Elementary English)

English Independent User (B1, B2)

B1 (Intermediate English)

B2 (Upper-Intermediate English)

Proficient English User (C1, C2)

C1 (Advanced English)

C2 (Proficiency English)

Identify your level with free English placement test

Start the free pre-test

A levels- English Basic User

English test A1 (Beginner)

Can understand and use familiar everyday expressions and very basic phrases aimed at the satisfaction of needs of a concrete type. Can introduce him/herself and others and can ask and answer questions about personal details such as where he/she lives, people he/she knows and things he/she has. Can interact in a simple way provided the other person talks slowly and clearly and is about the grammatical constructs of the language in question.

The theme of our qualification paper is "Teaching Grammar in A1 level".

The Creative Grammar Practice section provides ideas for a deeper and more personalised familiarisation with these items, always with an element of individual creativity. Each lesson ends with the creation of a learner text - a permanent and original record of the grammar, in the form of a story or a poem for example.³⁶

Teaching Grammar Creatively works without explicit grammar rules like class-books normally do. The idea behind it is that especially younger learners need to learn more subconsciously. This is called Awareness-raising, meaning the students discover the language and find the rules for themselves while the teacher

³⁵ <https://tracktest.eu/english-levels-cefr/>

³⁶ https://books.google.co.uz/books/about/Teaching_Grammar_Creatively_with_CD_ROM.html?id=3eAlsBT9LoC&redir_esc=y

only provides a frame in which the learners work. This learner-led method is said to be more efficient because these self-done discoveries of rules lead to a reorganisation of the learner's knowledge. Thus the learners have a higher possibility to remember the rules and apply them correctly. The ability of applying rules subconsciously, rather than knowing them by heart, is the main goal of the whole approach.

2 3. Language Awareness Activities The Language Awareness activities or lessons are divided into three sections called Discovery, Consolidation and Use. This model sounds like the traditional Presentation, Practice and Production method which is often used in schools today, but the authors explain the differences between both ideas. (Gernegross p.7 ff) Because of the learner-led approach, the term Discovery is more appropriate than Presentation is as the learners are given data or are confronted with problems and then discover the according grammar themselves, instead of learning precisely what a teacher "presents" to them. According to the author, Practice mainly involves the learners in repeating given structures without really realizing how the given structures work. This is where Consolidation uses another way. Instead of simply repeating things or having a speaking practice, students will be confronted with understanding tasks. "For example, students may be asked to read (or listen to) a series of sentences – some including structure X and some including structure Y – and to match these sentences with the appropriate picture." (Gernegross p.7) The last section is Use. Contrary to Production, Use means not only that learners produce something concerning the taught grammar, but develop a personalized use. This means students use the new learned item in a context that is important to them. According to the author, language is only memorable when it has been owned.

4. Creative Grammar Practice Creative Grammar Practice provides further practice of grammar with focus on the individual creativity of the learners. Thus, students are thought to be more motivated. This section is also divided into a total of four smaller sections: Lead-in activities, Presentation of model text, Reconstruction of model text and Text creation. Lead-in activities are meant to be a sort of warm-up for the students and for getting ready to work in a foreign language. Presentation of model text is the presentation of a short text which shows the target structure and clarifies its function. In the section Reconstruction of model text learners shall remember the model text and recreate it from a gapped version for example. "[...] By remembering the model text the students can experience a feeling of success and gain ability in using structure(s) accurately." (Gernegross p.9) Finally, Text creation lets students create their own texts within the frame of the model text. This can be done in several ways: groups, orally, written...

3 5. Theory in practice After briefly explaining the theory behind Teaching Grammar Creatively, there will now be a look on how a chapter of grammar looks like. For this purpose the topic Adjectives/Adverbs (Gernegross p.97 ff.) was chosen. Like most of the units, the topic is subdivided into sections A and B – analogue to Language Awareness Activity and Creative Grammar Practice. The suggested time of both sections is approximately 50 minutes, thus a

little longer than the usual class session. Section A starts with the aims of the unit, followed by the first sub-section Discovery. Herein, the teacher is asked to write the words good and well on the board. Now, students shall fill the gaps of the sentences He cooks ___ and his food smells ___ with the two words. After this, other adjectives and adverbs shall be given that could fill the gaps. Now, the teacher is advised to “highlight the difference between the kind of words that go into the first slot [...] and the kind of words that go into the second slot [...].” (Gernegross p.97) After this explanation, the learners should complete other gapped sentences. Now the sub-section Consolidation starts. The teacher is advised to write down several adverbs and adjectives and read out a given text that includes gaps again. The learners are supposed to find appropriate adjectives or adverbs for the gap. This could also be done as a kind of competition between groups of learners. Finally, the sub-section Use concludes the first section. The teacher is supposed to write sentence frames on the board: What makes you feel...? / What makes you react...? And give a list of words that could complete each frame. After this, learners shall prepare questions to ask one another in pairs or groups and finally report on some of their conversation. This is the end of section A. Section B starts with advices for the teacher telling him which given texts should be copied. These texts are given on an accompanying CD. The four tasks of text work consist mainly in recreation and gap-filling. Concluding this section, the learners are supposed to go through the texts again and write out adjectives and adverbs. Finally, they shall write their own small texts similar to the ones they worked with. This completes the mainsection Adjectives/Adverbs.

Literature Review Most people, when they hear the word grammar, think of lots of useless, boring rules that they were forced to learn in school. However, recent studies in language teaching shows that if grammar is presented in a creative way it can be an enjoyable learning experience where learners subconsciously 'pick up' grammar of a language. Many educators and teachers now believe that grammar is a necessary and a desirable part of classroom language learning. Apart from the four language skills listening, reading, writing and speaking, grammar and vocabulary are considered as two more important skills. According to Davit Crystal, "grammar is the study of the way words, and their component parts, combine to form sentences"(Crystal 1985, p.141). This definition suggests that the vast majority of people of this world know grammar but they are not aware of it. According to Brumfit and Johnson, "The important point is that the study of grammar as such is neither necessary nor sufficient for learning to use a language" (Brumfit and Johnson, 1979,p.165). Therefore, grammar is the basic of any language and cannot be ignored in language teaching. In teaching grammar some general considerations are how to integrate grammar teaching into communicative methodology, which is aimed at developing ones competence, the level at which grammar is taught (elementary, intermediate, advanced), and what precise method the teaching should follow. And these have further implications about the choice of grammatical structures to present, what

kind of grammatical description to use, whether to use an inductive or deductive approach, what the role of practice might be and what forms of practice are appropriate for different types of learner.

Effective and creative grammar teaching: One of the most important teaching tools is lesson plan. In case of teaching grammar creatively, the PPP framework is helpful. A PPP lesson is divided into three phases: Presentation, Practice and Production. So it is not only presenting the grammar item then practicing it and lastly producing it, but also doing it in a creative and effective way that makes the whole learning successful.

To sum up, rather than leading students towards memorizing and repeating rules, students should pick up the rules of the language on their own from the context. In that case, teachers should teach grammar in a creative way where real life situation or activities will take place. Here are some examples of creative activities for elementary level students, which incorporate not only grammar but other skills as well.

Effective methods in teaching grammar. Today, we live in a society that prizes literacy and is willing to adapt to more effective methods to achieve the best results in teaching grammar. Through these methods learners can pay their attention, increase the vocabulary, effectiveness, quickness of wit, attentiveness and the main thing is to assimilate the lesson with the interest and learn by heart grammar rules and vocabulary.³⁷

Diagramming Sentences. One of the older forms of teaching grammar, diagramming sentences, first appeared in the 19th century.³⁸ This method involves visually mapping the structures of and relationships between different aspects of a sentence. Especially helpful for visual learners, this method disappeared from modern teaching at least 30 years ago. Different forms of diagramming are used to visualize sentences, but all organize the functions of a sentence in a way that illustrates the grammatical relationships between words. More recently, diagramming sentences has had small pop-culture resurgence in prints of famous opening sentences and websites that allow you to diagram to your heart's content.

Learning through Writing. This method is often used in schools in the U.S. and Canada. Students are encouraged to explore language through creative writing and reading, picking up correct grammar usage along the way. If there are specific problems with certain grammatical rules, these are covered in a more structured lesson. An emphasis is now being placed upon language acquisition over language learning, as it has been observed that learning grammar by memorization does not work well and that students are better able to recognize and understand grammatical rules when lessons are more interactive (they have to apply these rules in their own writing). Repeated practice is also important and easily achieved through creative or personal writing exercises. This article, posted

³⁷ Jie, X. (2008) Error theories and second language acquisition [Electronic version]. USChina foreign language, 6(1).

³⁸ <https://cyberleninka.ru/article/n/effective-methods-in-teaching-grammar-4>

by THE ATLANTIC, suggests that to better equip future adult writers, teachers in the 21st century should consider dropping outdated grammar teaching techniques in early education and opt for learning through writing techniques.

Inductive Teaching. The inductive method of teaching grammar involves presenting several examples that illustrate a specific concept and expecting students to notice how the concept works from these examples³⁹. No explanation of the concept is given beforehand, and the expectation is that students learn to recognize the rules of grammar in a more natural way during their own reading and writing. The main goal of the inductive teaching method is the retention of grammar concepts, with teachers using techniques that are known to work cognitively and make an impression on students' contextual memory.

Deductive Teaching. The deductive method of teaching grammar is an approach that focuses on instruction before practice. A teacher gives students an in-depth explanation of a grammatical concept before they encounter the same grammatical concept in their own writing. After the lesson, students are expected to practice what they have just been shown in a mechanical way, through worksheets and exercises. This type of teaching, though common, has many people—including teachers—rethinking such methods, as more post-secondary level students are revealing sub-par literacy skills in adulthood. As one former teacher states, deductive teaching methods drive many students away from writing because of the tediousness of rote learning and teacher-centered approaches.

Another method of teaching grammar is to incorporate interactivity into lessons. Using games to teach grammar not only engages students but also helps them to remember what they've learned. This method allows teachers to tailor their lessons to the different learning styles of students. For instance, each student can be given a large flashcard with a word on it, and the students must physically arrange themselves into a proper sentence.

Over the years, many methods have been developed for teaching grammar and have been built upon, abandoned, or combined, all with the same goal in mind—teaching students how to communicate effectively and understand how to use the English language. Regardless of how grammar is taught, a well-rounded understanding of English grammar is the most important factor in improving the literacy of students.

"The task of science is shaping our future directions of tomorrow, the laws of nature, the show the way it is. Science must be the means, by force, driving forward the development of societies."⁴⁰

Formation of the young specialist takes place in university classrooms, and time-consuming process of training based on the methods of teaching effectiveness that ultimately determines the skill level of the future specialist. The

³⁹ <https://cyberleninka.ru/article/n/efective-methods-in-teaching-grammar-4>

⁴⁰ Jie, X. (2008) Error theories and second language acquisition [Electronic version]. USChina foreign language, 6 (1).

fruitfulness of the joint activity of the teacher and the student depends on the correct problem solving:

a) Setting teaching objectives, and the consequent motivation for the student

b) The accomplishment of certain materials' contents

c) The control of knowledge.

Teachers should support their students when they want to resolve everyday problems that refers to learning languages, especially on learning grammar. There are several models of pedagogy study:

1) Passive — student acts as the “object” of study (listening and watching)

2) Active — student acts “subject” of learning (independent work, creative tasks)

3) Interactive — inter (mutual), act (act). The learning process is carried out in a continuous, active cooperation of all students. Students and teachers are equal subjects of study.⁴¹

Teaching students' grammar rules without giving the students an opportunity to use these rules will not help them use English in real life. Language teachers and language learners in many non-native countries are often frustrated by the disconnect between knowing the rules of grammar and being able to apply those rules automatically in listening, speaking, reading, and writing. This disconnect reflects a separation between declarative knowledge and procedural knowledge.

Native English speakers learn grammar rules from hearing and listening from the real situations.⁴² In many English classrooms, teachers often set aside a particular time slot that is dedicated to the study of grammar. Such periods often focus on different points of grammar, such as tense, active and passive voice, or reported speech.

Grammar is something that runs through just about every aspect of language. Even the simplest sentences have grammar. Our curriculum may require us to teach stand-alone grammar lessons, and it's important to introduce various grammar points and topics so that the students have a richer understanding of the mechanisms of language. In English classes we often include music of English feature. These highlight the structure of grammar and stress patterns of the key everyday expressions that are presented. As learners are keen to learn these high frequency expressions, it is well worth making sure that they know exactly how to use them with the correct of using grammar. For example, if we deal to Present Simple and Present Continuous the Beatles' songs are available:

Here comes the Sun

Here comes the Sun

⁴¹ [Электронный ресурс]. Режим доступа: https://www.educationworld.com/a_lesson/lesson/lesson33/ (дата обращения: 02.07.2018).

⁴² [Электронный ресурс]. Режим доступа: <https://www.inklyo.com/methods-of-teaching-grammar/> (дата обращения: 02.07.2018).

And I say
It's alright
Little darling.
I feel that ice is slowly melting
Little darling.

To check the learners how to understand these two tenses we can use interactive ask-answer methods such as: Here comes the Sun. Who comes here? Where does the Sun come from? In addition, I say it is all right. What do I say? I feel that ice is slowly melting. What is slowly melting? How is ice melting? What is ice doing? Testing your grammar for learners of Intermediate and Upper-Intermediate levels will be fruitful, in which a text is given to put the events into chronological order. What happened first? What happened last?

As I am interested teaching grammar to young learners I usually use the text-book "Developing Grammar in Context" by Mark Nettle and Diana Hopkins in which exercises have been added the activities of interaction as: brainstorming, cluster, games such kind of feeling jar, how to place the order of adjectives, ready-made picture, case-studies and others. These activities focused on how grammatical concepts can be practiced with fun in the classroom.

For conclusion, I want to argue that it will be worth to teach grammar by interesting interactive grammar activities, which are designed for pre-grammar, while-grammar and post-grammar stages. In pre-grammar stage, we can use declarative approach to explain all features of certain grammar function with helping interactive methods. In while-grammar stage, we can gain and fix of new grammatical combination and in post-grammar stage, students are led to follow grammar accuracy in speaking with using some interactive methods.

The list of used literature:

1. [Электронный ресурс]. Режим доступа: https://www.educationworld.com/a_lesson/lesson/lesson33/ (дата обращения: 02.07.2018).
2. Alexander, L.G. (1991). Longman English Grammar. Essex: Pearson Education Limited.
3. Asher, J. (1997). Learning Another Language through Actions: The complete. Teacher's Guide Book. Los Gatos, Calif.: Skz Oaks Oroductions.
4. Carter, R. and McCarty, M. (2007). Cambridge Grammar of English. Cambridge: Cambridge University Press.
5. Fangjie zhang. (1993). Oxford Advanced Learner's Dictionary of Current English with Chinese Translation. Beijing: The Commercial Press, Oxford University Press.

TA'LIM TIZIMIDA SMART TEXNOLOGIYASIDAN FOYDALANISH SAMARADORLIGINI OSHIRISH

Annotatsiya: Ushbu maqolada ta'lim tizimida o'quvchilarning intellektual salohiyatini rivojlantirishda smart texnologiyasining ahamiyati to'g'risida fikrlar bayon etilgan. Dars jarayonida smart texnologiyani qo'llash natijasida o'quvchilarning intellektual salohiyati va ilmiy nazariy bilimi yanada mustahkamlanadi. Shuning bilan birgalikda, ta'limda axborot va kommunikatsiya texnologiyalar va zamonaviy pedagogik texnologiyalarni joriy etish ta'limni yanada boyitish, takomillashtirishga olib keladi.

Kalit so'zlar: ta'lim, axborot texnologiyalari, smart texnologiyasi, informatika, innovatsiy, pedagogik texnologiya.

*Umarova R.U.
teacher
of Andijan state university*

IMPROVING THE EFFICIENCY OF USING SMART TECHNOLOGIES IN THE EDUCATION SYSTEM

Annotation: This article discusses the importance of intelligent technologies in the development of the intellectual potential of students in the education system. The use of smart technology in the classroom further enhances the intellectual potential and scientific and theoretical knowledge of the students. At the same time, the introduction of information and communication technologies and modern pedagogical technologies in education will lead to further enrichment and improvement of education.

Keywords: education, information technology, smart technology, informatics, innovation, pedagogical technology.

XX asrning 90-yillaridan boshlab axborotlashtirish sohasi keskin rivojlanib ketdi. XXI asr axborotlashtirish va kommunikatsiya asri, deyish an'anaga aylandi. Axborotlashtirish nima va uning vazifalariga nimalar kiradi, uning asosiy xususiyatlari qanday, degan savollar jamiyatdagi har bir fuqaroni qiziqtirishi tabiiy. Chunki inson faoliyatini axborotsiz tasavvur qilish qiyin.

Kundalik turmushda turli ko'rinishdagi axborotlar masalan, matnli, grafikli, jadvalli, ovozli (audio), rasmlil, video va boshqa axborotlar bilan ishlashga to'g'ri keladi. Har bir turdagi axborot bilan ishlash (yig'ish, saqlash va

h.k.) uchun turli texnik xarakteristikalarga ega bo'lgan axborot qurilmalari kerak bo'ladi.

Mikroelektronika ishlab chiqarish texnologiyasining rivojlanishi va zamonaviy protsessorli kompyuterlarning yaratilishi axborotlarni qayta ishlash imkoniyatlarini kengaytirmoqda.

Hozirgi kunda ta'lim sohasida o'qitishni kompyuterlashtirishga katta e'tibor berilmoqda, chunki zamonaviy o'qitish texnologiyalaridan dars jarayonida foydalanish katta ijobiy natijalar beradi. O'qitishni kompyuterlashtirish (axborotlashtirish) yoki axborot texnologiyalaridan foydalanish dasturiga quyidagilarni kiritish mumkin:

- ✓ ta'lim tizimining barcha pog'onalarida axborotlashtirishni yetakchi bo'g'inligini ta'minlash;
- ✓ barcha sohalar bo'yicha bilim berishda axborotlashtirishni rivojlantirishni loyihalash va yaratish (monitoring);
- ✓ axborotlashtirish sohalarida me'yoriy bazalarni yaratish (ilmiy-metodik birlashmalar va h.k.);
- ✓ texnik ta'minot – kompyuterlar, axborot texnologiyasining boshqa qurilmalari, ularga xizmat ko'rsatish uchun kerakli materiallarni yaratish;
- ✓ telekommunikatsiya tarmoqlari;
- ✓ ta'minot resurslari (dasturiy ta'minot, internetdagi axborotlar majmui, ma'lumotnomalar va h. k.).

Axborot texnologiyasidan foydalanish va uni biror-bir sohaga tatbiq etish o'z ichiga qator vazifalarni oladi. Quyida axborotlashgan faoliyat ob'ektlari haqida so'z yuritamiz.

Bunday ob'ektlarga sonlar (o'lchash va modellashtirish natijalari), matnlar, tasviriy axborotning statistik va dinamik ifodalari, rasmlar, chizmalar va animatsiyalar, ovozli obrazlar (yozilgan ovoz, musiqa) va boshqalar kiradi. Foydalanuvchining mustaqil va ongli ravishda olib boradigan faoliyatiga axborot ob'ektlarini yaratish, zarur axborot ob'ektlarini izlash, axborotlarni yig'ish, tahlil qilish va ajratib olish, tashkillashtirish, kerakli ko'rinishda tasvirlash, axborot ob'ektlarini (matn, suhbat, rasm, o'yin va boshqa ko'rinishda) uzatish, modellashtirish, loyihalash, ob'ektlarni rejalashtirish va boshqalar kiradi.

Ta'lim tizimida yoshlarga zamonaviy bilim berishda innovatsion texnologiyalarning o'rni beqiyos. Dars jarayonida ilg'or pedagogik texnologiyalarni qo'llashda hamda zamonaviy uslublar ta'limning sifat va samaradorligini oshiradi, raqobatdardosh kadrlar tayyorlashga xizmat qiladi. Har bir dars, o'quv predmetining o'ziga xos texnologiyasi bor. O'qituvchi va talabaniq maqsadi ijobiy natijaga erishish ekan, darsda qanday texnologiyadan foydalanish ular ixtiyorida. O'qituvchining mahoratiga qarab, kompyuter bilan ishlash, film, tarqatma material, plakat, axborot texnologiyasi, turli adabiyotlar, puxta loyihalangan interfaol usullar qo'llash mumkin.

Mavzu materialini bayon etish paytida o'quvchilarga savollar berish ham yaxshi samara beradi. Bunda o'qituvchi o'quvchilarning materialni qanday

o'zlashtirganliklarini bilib oladi. Shu bilan birga, o'quvchilar o'qituvchining istagan paytda so'rab qolishini bilib, uni diqqat bilan eshitadilar. O'quvchilarni o'qituvchiga savollar berishga odatlantirish o'quv materialining muvaffaqiyatli o'zlashtirilishiga yordam beradi. Shuningdek, o'quvchilarning fikrlash qobiliyatini oshiradi. O'quvchilarni faollashtirish, ularda o'tilayotgan darsga qiziqish uyg'otish ham pedagogga bog'liq.

O'quvchilar savolni butun material yoki uning ayrim qismlari bayon etib bo'linganidan keyin berishlari kerak. Aks holda savollar o'qituvchini asosiy fikrdan chalg'itishi, natijada bu metodik usul foyda o'rniga zarar keltirishi mumkin.

O'quvchilar charchashi oqibatida ko'pincha ularning diqqat-e'tibori va faolligi pasayadi, buni o'quv materialini bayon etishda hisobga olish zarur. Uzoq vaqt e'tiborni jalb etish ham charchatadi, o'quvchi o'qituvchining so'zlarini diqqat bilan eshita olmaydi, chalg'iy boshlaydi. O'quvchilar darsdan charchamasligi, diqqatini darsga jalb qilish usullaridan biri – dars o'tish uslubining xilma-xil bo'lishida. Tajribali o'qituvchilar o'quvchilar o'zlashtirishi qiyin bo'lgan materialni darsning birinchi yarmida, takrorlash, o'quvchilardan so'rash va bilimlarni puxtalashni darsning ikkinchi yarmida o'tkazadilar. Keng ko'lamli islohotlarning muhim bo'g'ini – innovatsiyalar bugun har bir sohada bo'lgani kabi ta'lim tizimida ham o'zining afzalliklarini namoyish etmoqda. Innovatsiyalar dolzarb, muhim ahamiyatga ega bo'lib, bir tizimda shakllangan yangicha yondashuvlardir.

AKT rivojlanishining zamonaviy bosqichida nafaqat klassik ta'lim texnologiyalari, balki yelektron ta'lim (e-learning) ham qanoatlantira olmaydigan yehtiyojlar kuzatiladi. Ayni vaqtda ye-learning tizimidan Smart (ingl. — aqlli, mushohadali, harakatchan) ye-learning hamda Smart Yeducation (aqlli ta'lim) ga o'tish jarayoni bormoqda. Bu konsepsiya ta'lim sohasining barcha jarayonlarini, shuningdek, bu jarayonda qo'llaniluvchi barcha usul va texnologiyalarni kompleks modernizatsiyasini mujassamlashtiradi. Smart konsepsiyasi ta'lim kesimida o'zi bilan birga, «aqlli taxta», «aqlli yekran», ixtiyoriy nuqtadan Internetga chiqish kabi texnologiyalarni shakllantiradi. Ushbu texnologiyalarning har biri kontentni ishlab chiqish jarayonini yangidan qurish, yetkazib berish va aktuallashtirish imkonini beradi. Natijada ta'lim olishni nafaqat sinfda, balki uyda, ish joyida, jamoat joylarida, dam olish joylarida ham amalga oshirish mumkin bo'ladi. Bunda ta'lim jarayonini baholovchi asosiy yelement sifatida faol ta'lim beruvchi kontent maydonga chiqadi. Uning asosida vaqt va fazo tushunchalari to'sig'idan holi qiluvchi yagona repozitor yaratiladi.

Smart ta'lim konsepsiyasi — mavjud manbalarga tez moslashuvchanlik, multimedaning maksimal xilma-xilligi, tinglovchining saviyasi va talabi darajasiga tezkorlikda moslashuvchanlikdan iborat. Kompetentlikning uzluksiz rivojlanishi, bilimlarni doimiy o'sishi va yangilanib borishi zamonaviy ta'lim tizimidagi dolzarb muammolardan hisoblanadi. Sababi bilimni rivojlantirish uchun yendi inson kapitalining ta'siri kamlik qila boshlaydi. Bu kabi masalalarni

hal qilishda nafaqat ta'lim muhitining o'zini, balki ta'lim tizimining tarkibi, instrumentlari, usullari tubdan o'zgartirilishi shart. Analitik kompetensiyalar, kompleks muammolarni yechish mahorati, yangi g'oyalarni rivojlantiruvchi — innovatsion xususiyatlar, o'zaro kommunikatsiya madaniyati kabi bilimlarni takomillashtirish zarur. Chunki an'anaviy ta'lim parametrlari asosida bilim berish insonlarni Smart — jamiyat uchun tayyorlamaydi (1-rasm). O'z navbatida, Smart — texnologiyasiz, innovatsion faoliyat yuritib bo'lmaydi. Agar ta'lim shu yo'nalishda ortda qolsa, u tormozlanib, qotib qoladi.

Hozirgi kunda, o'quv darslarida, multimedia vositalaridan foydalangan holda, Microsoft Power Point yoki Macromedia Flash dasturiy paketlarida tayyorlangan taqdimotlarni qo'llash oddatiy holga aylanib bormoqda, biroq shu bilan birga, ta'lim sohasiga shunday interfaol texnologiyalar kirib kelmoqdaki, ular slayd-shou turkumidagi taqdimotlarni siqib chiqarmoqda. Axborotlarni talabalarga yangi interfaol uskunalari (interfaol taxta — Smart Boards, interaktiv display — Sympodium) yordamida uzatish, ma'ruzachiga dars jarayonining o'zida taqdimotlar yaratish imkonini beradi. Interfaol Smart Boards taxtalariga maxsus markerlar yordamida yozish, o'quv materiallarini namoyish yetish, yekrandagi tasvir ustidan yozma sharhlar berish mumkin. Shu bilan birga, interfaol Smart Board taxtasiga yozilgan ma'lumotlarni magnit tashuvchilarda saqlanib qolib, ularni bosib chiqarish, darsga kelmagan talabani yelektron pochtaga yuborish amalga oshiriladi. Ma'ruza davomida Smart Board taxtasida yaratilgan o'quv materialini yesa, o'rnatilgan videokoderga yozib olib, ko'p marta qayta qo'llanishi mumkin.

Albatta bugungi kunda interfaol smart taxtalar imkoniyatlaridan maksimal foydalanish uchun maxsus dasturiy ta'minotlar (Smart Notebook, Bridgit, Synhron Yeyes) ishlab chiqilgan. Mazkur dasturiy ta'minotlar har birining o'z imkoniyatlari mavjud. Masalan, Smart Notebook matnlar va obyektlar bilan ishlaydi, axborotlarni saqlaydi, yozma harflarni bosma harflarga aylantiradi. Bridgit dasturi taqdimotlarni tez va osonlik bilan butun dunyoning turli nuqtalaridagi hamkorlarga tarqatadi, o'z hujjatlariga taqrizlar oladi. Buni amalga oshirish uchun o'qituvchi chiqishidagi muhim pozitsiyalarini umumiy «ishchi stol»da ajratib ko'satishi bilan shu oning o'zidayoq, dastur real vaqtda, barcha konferensiya ishtirokchilari oynasida paydo bo'ladi. Synhron Yeyes (sinxron ko'z) dasturiy paket yordamida o'qituvchi barcha o'quvchilarni kuzatib turishi, o'quvchilar ishchi monitorlarini yekrangga chiqarishi, blokirovka qilishi, interfaol taxta yordamida o'quv materiallarini, darsliklarni, testlarni yuborishi va jarayonni nazorat qilishi mumkin.

Yangi pedagogik texnologiyalarning afzalligi shundaki, unda mashg'ulotlar muvaffaqiyatli o'tishining 80 foizi ta'lim jarayonini to'g'ri loyihalashtirish, tashkil etish va uni amalga oshirishga bog'liq.

Innovatsion ta'lim o'qituvchi faoliyatini yangilash, ta'lim-tarbiya jarayonini maqbul qurish bilan birga, o'quvchi va talaba yoshlarda bilimga

chanqoqlik, hurfikrlilik, vatanparvarlik va insonparvarlik tuyg'ularini shakllantirishga ijobiy ta'sir ko'rsatadi.



1-Rasm⁴³.

Foydalanilgan adabiyotlar:

1. Ўзбекистон Республикасининг “Таълим тўғрисида”ги Қонуни. // Баркамол авлод -Ўзбекистон тараққиётининг пойдевори. – Т. Шарқ. 1997.
2. Усманова Г.А. Тажриба-тадқиқот майдонларида илғор педагогик технологияларидан фойдаланиш. // Журнал Таълим технологиялари №1, - 2012, - б. 29-32.
3. Umida Aripova Smart ta'lim texnologiyasi, Toshkent axborot texnologiyalari universiteti, infoCOM.UZ Jurnalni 2017 yil.

⁴³ Umida Aripova *Smart ta'lim texnologiyasi*, Toshkent axborot texnologiyalari universiteti, infoCOM.UZ Jurnalni 2017 yil.

*Usmonova Sh.R.
teacher
of department of foreign languages
faculty of agro engineering and hydro melioration
Andijan Institute of Agriculture and Agro technologies
Uzbekistan, Andijan*

THE USE OF MODERN EDUCATIONAL AND INFORMATION AND COMMUNICATION TECHNOLOGIES IN THE PROCESS OF TEACHING ENGLISH LANGUAGE

Abstract: The article presents the methods and practices of the use of ICT, design and technology research in the learning process. It is currently impossible to imagine a lesson without the use of ICT. The term ICT is directly related to information technology of education, which consists in the process of preparing and transmitting information to the student, the means of which is a computer. At the same time, we form in students information and technological competence - the willingness to use, reproduce, improve the means and methods of obtaining and reproducing information in electronic form, the ability to use modern computer technologies.

Key words: foreign language, network resources, sites and materials, development, new information technologies.

Information material in the practice of any teacher is a multimedia presentation. The advantages of presenting new material with its use are clear to everyone: saving time in the lesson, visibility, attracting the attention of students. Undoubtedly, high-quality preparation and demonstration by the teacher in the classroom of presentations is necessary, but this is an indicator of the teacher's information competence. And it is important for us to form this competence in the student. Almost every student has a computer at home and has certain skills to work with it. The task of the teacher (not only of computer science) is to develop these skills within the framework of their subject.

Methods used directly in the lessons of the English language and in extracurricular activities for the formation of information competence:

Search and collection of information - work with reference books, the Internet, e-mail. The ability to search for information on the Internet in a classroom where there is no stationary computer allows the use of a laptop and 3G Modem.

Information processing - ordering information, drawing up plans for the text, tables and other forms of visualization, analysis and generalization of information obtained from training materials, discussion.

Conducting a lesson in a computer science classroom allows all students to be involved in information processing at the stage of learning new material. Students are encouraged to structure the educational material in a form convenient for them: plan, abstracts, table, diagram.⁴⁴

The use of the simulator significantly saves time in the lesson, allows you to immediately get the result, identify gaps and organize the necessary assistance for students in eliminating them, forms the ability to work with the test.

Information transfer - preparation of reports, messages, posters, presentations for educational material, extracurricular activities. As an example, we can cite the preparation of presentation materials for literature lessons in the study of the work of writers of the XIX, XX centuries, extracurricular activities, preparation of abstract and competitions at various levels.

The transfer of information plays an important role in the formation of communicative competence. Complex methods - preparation and defense of an abstract (project), including drawing up a plan, conclusions, bibliography, participation in educational projects with their subsequent interpretation and public presentation of the results, educational research work, the release of student media.

The use of ICT tools was demonstrated at an open uneven-age lesson on the topic "Union less complex proposal" in the framework of the city seminar "The role of the deputy director in solving issues of informatization of an educational institution."⁴⁵

The combination of traditional forms and methods of working with ICT makes it possible to significantly intensify the cognitive activity of students, forms the skills of self-control, mutual control, increases the quality of assimilation of the proposed educational material and the development of skills for completing USE tasks by consolidating and structuring educational information, and also develops the creative abilities of learners.

The results of the questionnaire, revealing interest in subjects, showed the following.

About 60% of students explain the choice of the English language and literature by the fact that it is interesting to find additional information themselves, prepare messages, and speak with them in front of the class. About 70% of the students noted that they are interested in solving problems in the classroom and at home, performing exercises, practical work, filling out tables, maps, diagrams.

It seems that these results are largely related to the use of ICT. The use of design, research technologies in the learning process and educational work

⁴⁴ Egamberdiyeva D.U. Methods of using computer technology in the process of teaching English. . International scientific journal. Economy and society. № 6(73) -s.: 2020.

⁴⁵ Aldashev I. Modern information technologies in education is a new opportunity//Economy And Society. № 6(73) -S.: 2020.

One of the main goals of research developmental technology is the development of the personality of students on the basis of mastering the culture of research as a universal means of cognizing reality.

An important role in this case is played by the forms of conducting a lesson of the English language or literature: a lesson-conference, a lesson-research, a lesson-journey. One of the tasks implemented in these lessons is the development of a research type of thinking in schoolchildren.

The types of activities that form students' research skills:

- study of literature on the topic, analysis of the information received (bibliography, abstracting, citation);
- research planning (setting goals and objectives, choosing research methods, forecasting results);
- research (observation, experiment, fixing the results, comparing the results with the planned);
- registration and protection of research results (preparation of a report, writing an article, research work, protection of results in front of an audience).

Undoubtedly, it is impossible to use all types of research activities in one lesson. The development of research skills takes place in stages. And here the activity approach in teaching, the use of heuristic methods, is seen as important, when the student, observing the linguistic material, himself formulates a rule or draws conclusions about the idea of a work of art. The knowledge gained in this way becomes the most valuable.

The use of creative assignments in the lesson, searching for answers to a problematic question, working with additional literature, arguing for one's point of view also help to develop research skills.⁴⁶ The experience of such work in the classroom was presented to colleagues and the parental community in the form of a master class "Can we read at the forum of pedagogical workers." It should also be said about the use of individual and group design technologies, which provide for the complex nature of students' activities.

I start teaching students to create small individual projects from the 6th grade. This is preparation for public speaking. There is practically no subject in which students do not have to speak in front of an audience. In addition, any teacher will say that most schoolchildren have difficulties when it is necessary to construct a statement in an official setting and pronounce it in front of the class. A rare student can consciously, emotionally present a message, report, essay. At best, it will be a memorized, emotionless speech, at worst - a speech read from a piece of paper. Therefore, one of the teacher's tasks is to form the student's ability to prepare a speech, pronounce it so as to convince, interest the audience [1,1].

Performance indicators can be the achievements of students:

⁴⁶ Nuritdinova Y.A. The use of multimedia presentations when learning English. International scientific journal. Economy and society. № 6(73) -s.: 2020.

- the acquisition by students of experience in creative, project, research activities (i.e., readiness to search for solutions to new problems, independent transfer of knowledge and skills to a new situation);
- creation of an individual portfolio of students based on the results of participation in competitions, conferences;
- increasing interest in the subject;
- consistently high quality of knowledge on the subject;
- 100% progress;
- successful passing of exams;
- participation and victories in competitions of various levels from school to federal;

And also the demand for experience by teachers of a school, city, region (conducting master classes, open lessons, speaking at seminars).⁴⁷

Literature:

1. Egamberdiyeva D.U. Methods of using computer technology in the process of teaching English. . International scientific journal. Economy and society. № 6(73) -s.: 2020.
2. Aldashev I. Modern information technologies in education is a new opportunity//Economy And Society. № 6(73) -S.: 2020.
3. Nuritdinova Y.A. The use of multimedia presentations when learning English. International scientific journal. Economy and society. № 6(73) -s.: 2020.
4. Qodirova G.T. The didactic concept of teaching based on computer technologies. International scientific journal. Economy and society. № 6(73) -s.: 2020.
5. Negroponte N. Being digital. New York. 1995.
6. Pelgrum W.J. The educational potential of new information technologies. Helsinki: SITRA 180. 1998.

⁴⁷ Qodirova G.T. The didactic concept of teaching based on computer technologies. International scientific journal. Economy and society. № 6(73) -s.: 2020.

UDK: 32.09.34

*Yusupov R.M., candidate of historical sciences
associate professor
Andijan Institute of Agriculture and agrotechnologies
Uzbekistan, Andijan
Yusupova U.K.
Excellent public education
teacher of historical science
38 - general secondary school
Izkankan District Department of Public Education
Uzbekistan, Andijan*

RULE OF LAW IN HISTORICAL DEVELOPMENT

Annotation. In the article, historical development focuses on the development of the state of the normative fields of the periods, views of the great encyclopedic scholars of his time and their great works, the development of the Jam takes place in Allah.

Keywords: society, personality, culture, strategy, law, Avast, Islam religion.

*Юсупов Р.М., Тарих фанлари номзоди
доцент
Андижон қишлоқ хўжалиги ва агротехнологиялар институти
Ўзбекистон, Андижон
Юсупова У.К.
Халқ таълими аълочиси
Избоскан туман Халқ таълими бўлими
38- умумий ўрта таълим мактаби тарих фани ўқитувчиси
Ўзбекистон, Андижон*

ТАРИХИЙ ТАРАҚҚИЁТДА ҚОНУН УСТУВОРЛИГИ

Аннотация. Мақолада, тарихий тараққиёт даврлардаги меъёрий қонунларни давлат тараққиётига қаратилгани, ўз даврининг буюк қомусий олимларни қарашлари ва уларнинг буюк асарларида жамият тараққиёти ривожини ёритилганлиги алоҳида ўрин эгаллайди.

Калит сўзлари: жамият, шахис, маданият, стратегия, қонун, Авесто, ислом дини.

Жамият моддий дунёнинг таркибий қисми бўлиб, кишилар ҳаётининг фаолиятларининг мажмуидир. Шунингдек, кишилик жамияти тарихий тараққиётнинг муайян босқичда жамиятни вужудга келтирган ва ўз қонуниятларини яратган, қонунлари доирасида эҳтиёжларини таъминлаган.

Маълумки бу борада Фуқаролик жамиятининг шаклланиши ва ривожланишда Ўзбекистон Республикаси Президенти Шавкат Мирзиёевнинг “Ўзбекистон Республикасини янада ривожлантириш бўйича ҳаракатлар стратегияси тўғрисида”ги Фармонида (7 феврал 2017 йил) мамлакатимизда ижтимоий-сиёсий ҳаётни, давлат ва жамият қурилишининг барча соҳаларини демократлаштириш ва либераллаштириш, инсон ҳуқуқ ва эркинликларини ҳимоя қилиш, фуқаролик жамиятини шакллантиришда аҳоли иштирокини таъминлашнинг асосий йўналишлари асосида ишлаб чиқилган.

Биринчидан, давлат ва жамият қурилиш тизимини такомиллаштириш, мамлакатни модернизациялаш ва демократик ислоҳотларни чуқурлаштиришда Олий мажлис ва сиёсий партияларнинг ролини кучайтириш, давлат бошқаруви тизимини ислоҳ қилиш, жамоатчилик назорати институтини кучайтириш.

Иккинчидан, қонун устуворлигини таъминлаш ва суд-ҳуқуқ тизимини янада ислоҳ қилиш, суд ҳокимиятининг чинакам мустақиллигига эришиш, судларни мавқеини ошириш, фуқароларнинг ҳуқуқ ва эркинликларини ишончли ҳимоя қилинишини кафолатлаш.

Учинчидан, иқтисодий ривожлантириш ва либераллаштириш. Макроиқтисодий барқарорлик ва иқтисодийтимизда юқори ўсиш суратларни сақлаб қолиш. Иқтисодийнинг рақобатбардошлигини ошириш, унинг етакчи соҳаларни модернизация ва фаол диверсификация қилиш, Хусусий мулк ва тадбиркорликни янада ривожлантириш, Қишлоқ хўжалигида таркибий ўзгаришларни амалга ошириш. Туризм соҳасини ривожлантириш.

Тўртинчидан, ижтимоий соҳани ривожлантириш. Мухандислик-коммуникация инфратузилмаси ва аҳолига қулай уй-жой қурилишини ривожлантириш. Ижтимоий инфраструктурани ривожлантириш. Ижтимоий таъминот ва соғлиқни сақлаш тизимларини такомиллаштириш. Таълим ва фан соҳасини ривожлантириш. Ёшлага доир давлат сиёсатини такомиллаштириш.

Бешинчидан, хавфсизлик, миллатлараро тотувлик ва диний бағрикенгликни таъминлаш ҳамда чуқур ўйланган, ўзаро манфаатли ва амалий ташқи сиёсат. Хавфсизлик, диний бағрикенглик ва миллатлараро тотувликни таъминлаш. Пухта ўйланган, ўзаро манфаатли ва кониструктив ташқи сиёсатни амалга ошириш[1.7-11].

Бу ҳаракатлар стратегиясининг ишлаб чиқилиши ва ҳаётга тадбиқ этилиши, ўзбек халқнинг давлатчилк тараққиётининг қонунчилиги даражасини ифодалайди. Қонунчиликнинг манбаларини, қомусий олимлар томонидан батафсил ўрганилганлиги, фуқароларнинг ҳуқуқий онгини янада юксалтириб, халқ ҳокимиятчилигини бойитиб борган.

Абу Наср Форобий “Фозил одамлар шаҳри” асарида, ўз даврининг донишманди Афлотун қонунлари моҳиятини қуйидагича айтганидек, агар

соҳиби қонун оддий одамлар каби жохил бўлса, у одамларга наф келтирадиган қонунни жорий этолмайди.

Афлотун қонунларга риоя қилишда тарбия ва машғулотлар катта аҳамиятга эга эканлигини, ўзи қонунни менсимайдиган ва шу билан бирга қўли остидагиларни ҳам шунга ундайдиганлар ўз хатти-ҳаракатлари ила катта тартибсизликлар келтириб чиқаришини, қонунларнинг моҳияти ва афзалликларини халққа мантиқ ўқитиш ва ўргатиш орқали тушинтришни айтади.

Халқ қонунларга эҳтиёж сезиши ва уларни чуқур ўрганиши зарур, чунки улар кейинчалик халқнинг ўзига фойда келтирадилар. Акс ҳолда қонунда қўзланган мақсадга эришиб бўлмайди. Афлотун мисол келтириб, гўдак боланинг ҳунар ўрганишга зўр иштиёқи борлиги туфайли у ўйин орасида эшик ва уйларнинг қандай ясалишини ўрганиб олишини ва кейинчалик шу ҳунарни эгаллаб олишини, бу қобилиятнинг фойдаси тегишини айтади.

Афлотун айтадики, соҳиби қонун томонидан оғир ишлар ва машаққатли меҳнат билан боғлиқ бўлган матонат талаб қилиниши энг яхши адолатдир, чунки унинг пировардида қулайлик ва хайирли ишлар келади, бу ҳолат худди аччиқ, аммо соғлиққа яхши таъсир этувчи дори ичишга ўхшайди.

Афлотун, инсон табиий хислатларга эга-булар ундаги хулқ-атвор ва хатти-ҳаракатларга сабаб бўладилар, деб тушунтиради. Соҳиби қонун бу хислатларни назарда тутиши, уларни тузатиши, шу хислатларни тузатувчи қонунлар чиқариши керак, чунки бу билан соҳиби қонун фуқаронинг хулқ-атворини ҳам тузатади...

Афлотун турли қонунларнинг вужудга келиши, йўқолиши ва янгилиниши фақат унинг замонасигина тааллуқли бир янгилик эмаслигини тушинтиришдан бошлайди. Зотан қадим замонларда ҳам шундай бўлган ва келгусида ҳам шундай бўлади. Афлотун, қонунларнинг бекор қилиниши ва йўқолишига икки сабаб бор, деб ҳисоблайди. Биринчиси-уларнинг амалда қўлланиши муддатининг чўзилиб кетиши бўлса, иккинчиси-дунёда ҳамма халқлар учун ҳалокатли тўфон, вабо касаллиқги каби оммавий фалокатларнинг рўй бериши оқибатидир деб такидлайди[2.17-26].

Маълумки қадимги Турон заминида қонунчилик маданияти масаласида тўхталадиган бўлсак, қонунчилик милоддан аввалги 3-4 минг йилликлардаёқ шакилланган. Турон замини қонунчилик тарихига бой бўлиб, бу заминда энг қадимги қонунларнинг намуналари, диний-ҳуқуқий таълимотлари, мактаблари ва оқимлари пайдо бўлган. Бизнинг аждодларимиз маънавияти диний ва дунёвий қарашларининг уйғунлиги асосида шаклланган. Қонунга, давлат ва сиёсатга эътибор Марказий Осиё халқларида қадим замонлардан юксак бўлган.

Марказий Осиё халқларининг қадимги қонунчилик маданиятини ўрганишда дунё қонуншунос олимлари томонидан тан олинган манба

“Авесто” китобида диний, дунёвий, ахлоқий қонун-қоидалар билан бирга жиноят ва жазо каби масалаларга оид қонунлар ҳам битилган. Ушбу қонунчилик манбасида оиланинг поклиги, оилада бола тарбияси, оилавий турмушнинг мустаҳкамлиги ва муқаддаслиги масалалари атрофлича таъкидланган.

Ислом динининг Марказий Осиёга кириб келиши билан Самарқандда, Тошкент, Марғилон, Бухоро каби шаҳарларда фикҳ илми ғоят ривожланиб, Мовароуннаҳр фикҳшунослари “Қуръони карим” ҳамда “Хадис” ҳуқумлари ва қоидаларига асосланган ҳолда шариатни ривожлантирадиган қонунлар тизимини янада мукаммаллаштиришди.

Бу ўлкада қонунчилик маданиятини ривожлантирган муҳим манбалардан яна бири “Темур тузуклари”дир. Темур тузукларида давлатни қонун-қоидалар билан идора этиш санъати акс эттирилган. Биринчи навбатда давлатни дин ва шариат қонунлари билан, жамиятни эса 12 табақа ва тоифага бўлиб идора қилиш усули билан бошқарилган. Улар: 1) сайидлар, уламо ва шайхлар; 2) билимдон кишилар; 3) дуоғўй тақводорлар; 4) амирлар, сарҳанглар, сипоҳсолорлар; 5) сипоҳ билан раият; 6) доно ва ишончли кишилар; 7) вазирлар, саркотиб ва девон битикчилари; 8) ҳакимлар, табиблар, мунажжимлар ва муҳандислар; 9) муҳаддислар (ҳадис олимлари ва ровийлар); 10) сўфийлар ва орифлар; 11) ҳунар ва санъат аҳли; 12) сайёҳ ва тижорат аҳилларидан иборат бўлган[3.33, 79, 135].

Ўз даврининг етук жамиятшунос олимларининг жамиятни юксалтириш борасидаги ғояларидан кўп далиллар келтиришимиз мумкин. Албатта даврий нуқтайи назардан ёндашиладиган бўлса, ўз даврининг қонунларини кучини йўқалишига сабаб инсоният олмининг хоҳиш истаклари ва дунё қарашини ўсиб бориши муҳим ўрин эгаллайди. Бу борада жамиятда қонуннинг устуворлигини мустаҳкамланиши, фуқароларнинг қонунга риоя этишлари алоҳида аҳамият касиб этадилар. Бу ҳуқуқий билим ва қонунга асосланган ахлоқий меъёрларга киради. Етарлича ҳуқуқий маданиятга эга бўлган инсон қонун устуворлигини таъминлашда фаол бўлади. Чунки инсон ижтимоий тараққиётнинг асосий омили, дунёдаги энг олий мавжудот ва чексиз коинотнинг бебаҳо тожидир.

Умуман олганда қонун ва ўз даври учун яратилган қонунчилик маданиятига амал қилиб яшаш баркамол авлод келажагини ва кучли фуқаролик жамияти барпо этиш муваффақиятини таъминлайди.

Фойдаланилган адабиётлар рўйхати:

1. 2017-2021йилларда Ўзбекистон Республикасини ривожлантиришнинг бешта устивор йўналиши бўйича Ҳаракатлар стратегиясини “Халқ билан мулоқат ва инсон манфаатлари йили”да амалга оширишга оид Давлат дасткрини ўрганиш бўйича илмий-услубий рисола.-Т.: “Маънавият”, 2017. 7, 11 бет.
2. Абу Наср Форобий. Фозил одамлар шаҳри.-Т.: Абдулла Қодирий номидаги халқ мероси нашриёти, 1993. 17-26 бет.

3. Сагдуллаев А., Алимов Б., Мавлонов У., Норкулов Н. Ўзбекистон тарихи: Давлат ва жамият тараққиёти. - Т.: "Академия", 2000. 33, 79, 135-бет.

*Amanov O.A., PhD
docent Department of Innovative economy
of Karshi Engineering and Economic Institute
Uzbekistan*

THE IMPORTANCE OF DIGITAL TECHNOLOGIES IN ENSURING EMPLOYMENT

Annotation. In this article, an analysis of the employment of the population on the rural labor market is carried out, current problems and tasks of employment of the population are considered and highlighted. Also, suggestions and recommendations were made to address the problem in the labor market.

Keywords: labor market, digital economy, labor resources, innovation, innovative employment, human capital, labor reserve, unemployment, employment, employment problem.

Introduction

Innovative processes taking place around the world require the adaptation of each country's economic development strategy in this direction. The concept of human capital for sustainable socio-economic development of the national economy and the effective functioning of human resources are clearly defined role. At the same time, to ensure the sustainable development of the economy of the country depends on the reforms taking place in the labor market at the international level makes.

As noted in the Address of the President to the Parliament of our country, "Today we are moving on the path of innovative development aimed at radical renewal of all spheres of life of the state and society. This is not in vain, of course. Because who will win in today's fast-paced world? A state based on a new idea, a new idea, innovation achievements.

Innovation is the future. If we start building our great future today, we must start it on the basis of innovative ideas, innovative approaches." [1]

Indeed, today we are embarking on a path of innovative development proposed at radically renewing all spheres of life of the state and society. Based on the changes in this area, the tasks set by the President, on January 12 this year, the Cabinet of Ministers adopted a resolution "**On measures to create effective mechanisms for the introduction of scientific and innovative developments and technologies in production.**" The purpose of this decision is to improve the mechanisms of state regulation of innovation, improve the innovation environment, increase the efficiency and quality of research, create the necessary conditions for competitive scientific and practical results in domestic and foreign markets.

In the context of economic liberalization, the state pursues an active socio-economic policy to ensure employment of the able-bodied population, reduce unemployment, and regulate the labor market. Indeed, the use of labor potential, increasing its economic efficiency is an important source of joining the ranks of developed countries for the development of the national economy, improving living standards, and improving social life.

Referring to the structural analysis of **innovative employment**, which is a new type of employment, allows us to gain a deeper understanding of its overall formation, to determine the interdependence of its various levels of complexity, reversibility, flexibility, to study and evaluate structural changes, to identify objective causes gives

One of the main tasks in economic activity is to build a competitive economy in the Action Strategy for the five priority areas of development of Uzbekistan in 2017-2021, including the State Program "Year of Active Entrepreneurship, Support of Innovative Ideas and Technologies." Therefore, the training of competitive personnel in the labor market plays a very important role.

As the President of the country Sh.M. Mirziyoev noted, "Despite the need to employ 1.5 million people a year in our country, last year the Employment Assistance Centers employed only 248 thousand people or 16.5%. The main reasons for this are the outdated forms and methods of work, as well as the formality in solving employment problems "[1].

Today, more than 16,000 crimes, or one in four, are committed by unemployed citizens. Without addressing this problem, the intended results in crime prevention will not be achieved. To overcome this problem, every official must fully support businesses in the regions, help create new jobs, and take concrete measures to ensure self-employment of citizens. Therefore, one of the main tasks in our country is to "create new jobs and ensure the employment of the population, especially graduates of secondary special and higher education institutions, ensure the balance of the labor market and infrastructure development, reduce unemployment."

Literature review

Foreign and national economic theories have extensive experience in the analysis of the labor market at the present time, despite the scientific concept of "labor market" continues to be a heated debate. For many years the leading scientific schools, representatives of the labor market, labor or labor, the domestic market, the company sold the presence or absence of the essence: the price of labor (wages) or value (the value of the work force), and a clear idea of the purpose, etc. they cannot come. [3]

In particular, the number of supporters of the broad interpretation of the "labor market" as "a system of social relations, social norms and institutions that ensure the creation, exchange and use of labor" is growing. Among them are A.A Nikiforova and some other economists. show that it is necessary [4].

Economic scientists Kh.X.Abdurahmonov confirmation of this idea: "Labor market re-occurrence of the labor force: all stages of its production (socio-demographic perspective, the emergence of new labor force), circulation (purchase and sale activities) The distribution of the workforce (social, occupational and regional distribution) and used in the field of labor migration stages of the relationship between the employee and employer social system must be understood "[5].

The textbook "Labor Market Infrastructure" by Sh.R. Kholmuminov and N.U. Arabov provides a scientific and theoretical analysis of the interdependence of the labor market infrastructure and its components, a methodology for comprehensive assessment and forecasting of the effectiveness of its development, as well as governmental and non-governmental work. the main directions of formation and development of employment services have been identified. Also, a strategic concept has been developed to improve the organizational and economic mechanism of labor market regulation and increase the efficiency of labor market infrastructure development [6].

In the economic literature, along with the term "labor market" there is also the concept of "labor market". Often they are used in a sense. But it is necessary to find a reasonable answer to the question of whether these terms really mean the same thing or whether each of them has its own characteristics. In this regard, it should be noted that the former US Secretary of Labor tried to prohibit the use of the term "labor market" in official documents of the Ministry. According to him, the term "labor market" means that labor is sold and bought in the same way as grain, oil or metal. . On any given day, thousands of companies and thousands of employees will come to the market and try to implement this agreement. ” [7]

This approach was supported by the Russian economist, scientist A.O.Kotlyar. He denied the existence of the domestic labor market and employees to hire contract labor market conditions of documents, recruitment probe later date because they do not have to make any changes to the property market, sold, and used the power of the business concerned. [8]

Proponents of the concept of a broad interpretation of the concept of "labor market" believe that such a restriction narrows the scope of labor relations and leads to the restriction of the whole process to job search. According to them, there is every reason to consider the "labor market" in a broader sense, because the set of "employee-employer" social relations are social partners at all stages in which they work together, all the situations that may arise in the economic system, including production. rate of decline, unemployment, closure of the enterprise, reduction of wages, and so on.

The above description of the first part of the market economy, the labor market, and secondly, the ability to work in the labor market (labor), and thirdly, buying and selling system, labor market, social and economic relations in the country.

Methods of equalization and comparison, grouping and observation, statistical analysis, data collection, economic-mathematical, expert assessment, sociological research, drawing conclusions are widely used in the regulation of the rural labor market, data collection and analysis. It should be noted that research in the field of employment, labor market, mobilization of labor resources provides the necessary and reliable information to develop scientifically based programs of socio-economic development, to address social problems and conflicts that constantly accompany the work of employees.

Agricultural research, scientific analysis of the labor market on the one hand, and a real help to expand the existing knowledge about the reality, on the other hand, the employment of labor resources and related processes contribute to our society

Analysis and results

The results of reforms in the development of small business and private entrepreneurship in our country are also reflected in the indicators of employment.

The number of labor resources in the Republic of Uzbekistan in 2019 amounted to 18,672.5 thousand people, an increase over 2018 by 183.6 thousand people, or 1.0%.

In 2019, the share of employment in small business and private entrepreneurship in total employment was 78.3%. The share of employment in the public sector in the total employed population in the country was 17.3%, and in the private sector - 82.7%.

The number of economically active population in the structure of labor resources was 14357.3 thousand people (76.9% of the total labor resources), and the number of economically inactive population was 4315.2 thousand people (23.1%). The number of employed people in the country amounted to 13,520.3 thousand people, an increase of 1.7% compared to the same period in 2018 (Figure 1).

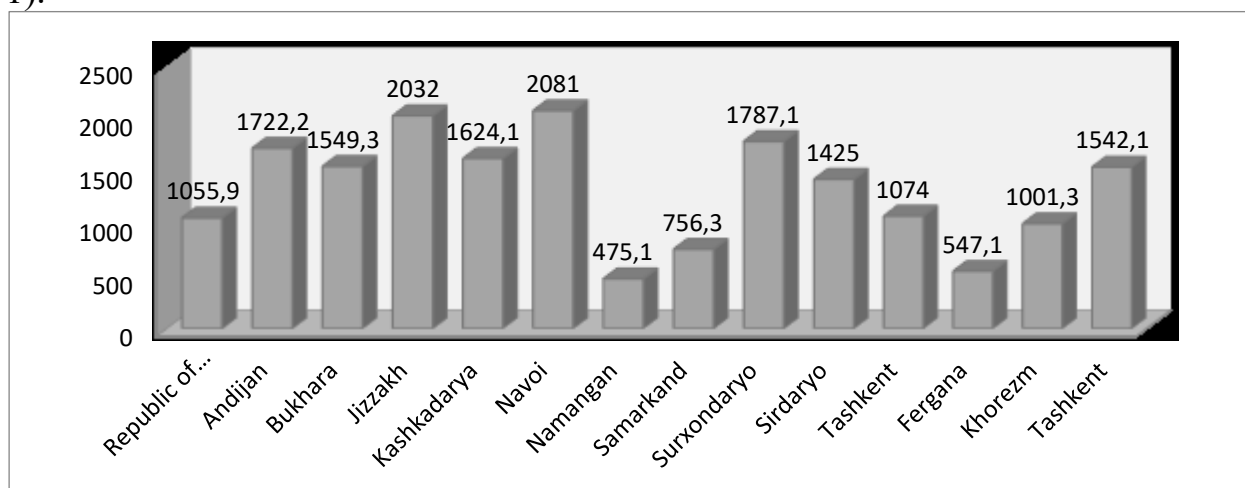

Figure 1. Distribution of the number of labor resources by regions (January-December 2019, thousand people)

Source: Data of the State Statistics Committee of the Republic of Uzbekistan

The forecast parameters of the State Program "Job Creation and Employment" in the country are the areas of employment by sectors and the need for employment in the regions, especially young people entering the labor market for the first time, structural changes in the economy and modernization of labor-intensive industries. the resulting vacancies, as well as the demand for labor as a result of the development of industry, agriculture and other sectors of the economy, the service sector, private business and entrepreneurship.

The number of employed people in the country increased by 1.7% compared to the same period in 2018. The share of employment in small business and private entrepreneurship was 78.3%.

In 2019, the number of employed population in 2018, compared to the high growth rates in transportation and storage by 2,6%, financial and insurance activities, 2.4%, 2.1% in construction and 1.9% in trade. The share of employees in the context of economic activities in agriculture, forestry and fishing (27.3%), industry (13.5%), trade (11.0%), construction (9.5%) and education (8, 2%) (Figure 2).

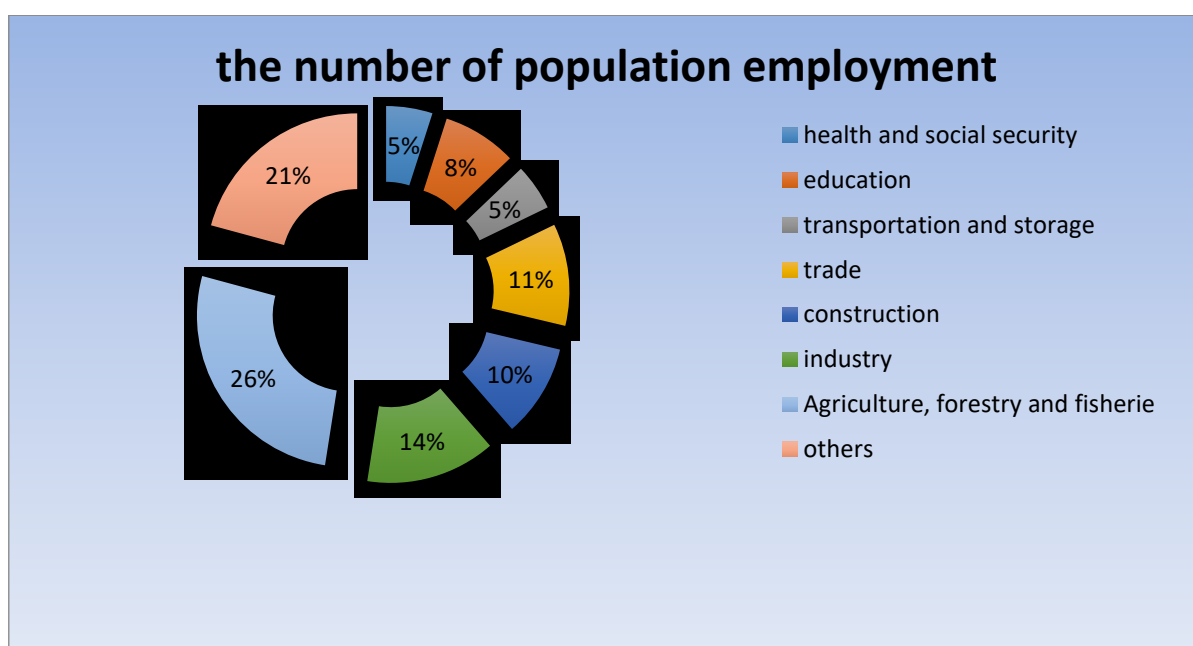

Figure 2. The number of employed kinds of economic activity. (January-December 2019, the percentage share of the total)

Source: State Statistics Committee.

At the end of December 2019, the number of unemployed registered as job seekers in the Republic of Uzbekistan amounted to 14.4 thousand people, an increase of 2.9 times compared to the corresponding period of 2018 (5.0 thousand people).

According to the methodology of registration of the unemployed in need of employment, approved by the Cabinet of Ministers of the Republic of Uzbekistan on May 24, 2007 No 106, the number of unemployed in January-December 2019

amounted to 837.0 thousand people and the unemployment rate relative to the economically active population Was 5.8%.

According to the State Statistics Committee of the Republic of Uzbekistan, the number of people employed in the economy in January-December 2019 amounted to 13,520.3 thousand people, an increase over 2018 by 1.7%. Analyzing the number of employed in terms of economic activity, a significant increase in the number of employed compared to 2018 was observed in transportation and storage (2.6%), financial and insurance activities (2.4%), construction (2.1%), trade. (1.9%), in accommodation and catering services (1.7%). The main share of the employed population is in agriculture, forestry and fisheries (27.3%), industry (13.5%), trade (11.0%), construction (9.5%) and education (8.2%).) sectors (Table 1).

Table 1

Distribution of the employed population by regions and types of economic activity
(January-December 2019, share in total items, in percent)

Regions	Agriculture, forestry and fisherie	industry	construction	services
Republic of Karakalpagistan	29,9	9,4	9,3	51,4
Andijan	26,8	13,9	7,3	52
Bukhara	30,2	13,3	15,2	41,3
Jizzakh	41,8	9,8	6,7	41,7
Kashkadarya	28,1	8,4	13,9	49,6
Navoi	22,3	26,9	12,3	38,5
Namangan	25,2	12,3	8,9	53,6
Samarkand	28,4	12,2	7,2	52,2
Surxondaryo	36,9	6,4	8,8	47,9
Sirdaryo	48	9,2	6,7	36,1
Tashkent	26,2	19,9	9,5	44,4
Fergana	27,6	16,9	7,9	47,6
Khorezm	35,6	8	9,5	46,9
Tashkent	0,9	19,1	11,2	68,8
Across the country	27,3	13,5	9,5	49,7

Source: Compiled by the author on the basis of data of the State Statistics Committee of the Republic of Uzbekistan

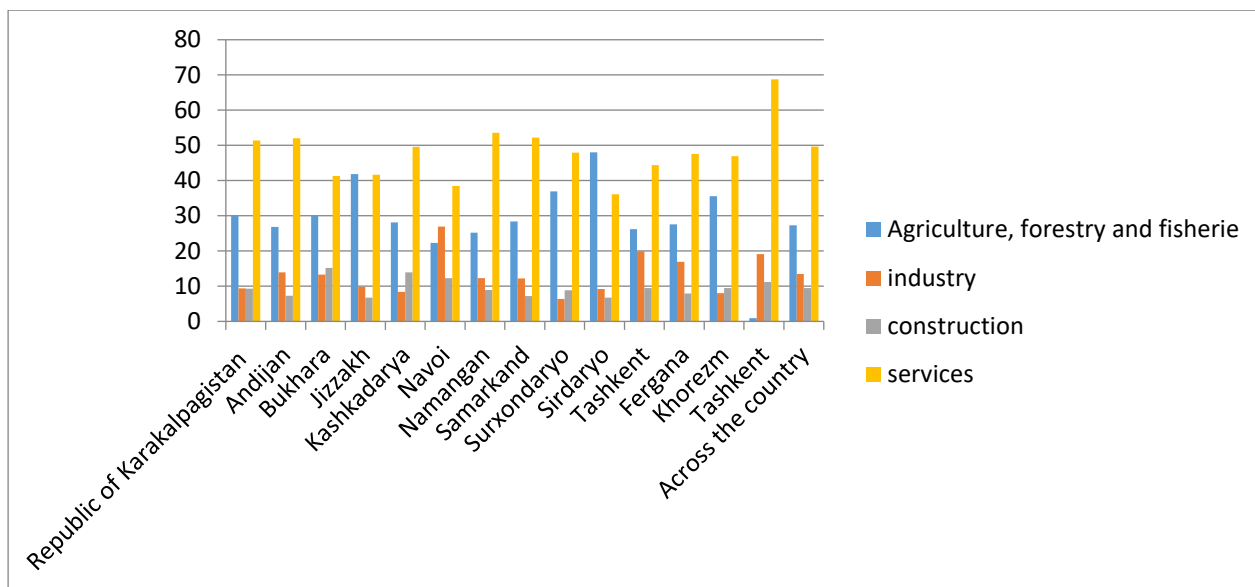

The graph 1 shows that when analyzing the number of employed people in the Republic of Uzbekistan by region and type of economic activity, in Jizzakh (41.8% of the total number of employed in the region) and Syrdarya (48.0%) regions, agriculture, forestry and fisheries, Navoi (26.9%), Tashkent (19.9%) regions and Tashkent city (19.1%) industry, Bukhara (15.2%) and Kashkadarya (13.9%) regions construction and in Tashkent city (68.8%), Namangan (53.6%), Samarkand (52.2%) and Andijan (52.0%) regions.

Despite the role and importance of the agricultural sector in the economy of our country, the problems of the rural labor market have not yet been studied extensively and in depth. This is also understood from the fact that no clear scientific conclusions have been drawn on the nature of the rural labor market, its functioning features, functions, mechanisms and other aspects.

In our opinion, the rural labor market is an integral part of the national labor market, characterized by the fact that it is located in the countryside in the region, where agrarian relations predominate.

The main features of the rural labor market, in our opinion, are as follows:

- monopsony of labor prices. It is known that a monopsony labor market means that one buyer (employer) has a large number of sellers (employees). Because, just as in some cities there is a single enterprise, in most rural areas the main economic entities - farms or agricultural enterprises - are the sole employers;

- In contrast to urban labor markets, rural labor markets are characterized by low labor and mobility per unit area, low labor mobility due to underdevelopment of the housing market and social infrastructure;

- Significantly longer duration of unemployment in rural areas than in urban areas. This is explained by the relatively slow pace of job creation in these areas. In particular, a significant increase in labor productivity as a result of institutional reforms in rural areas has led to the dismissal of excess labor [9].

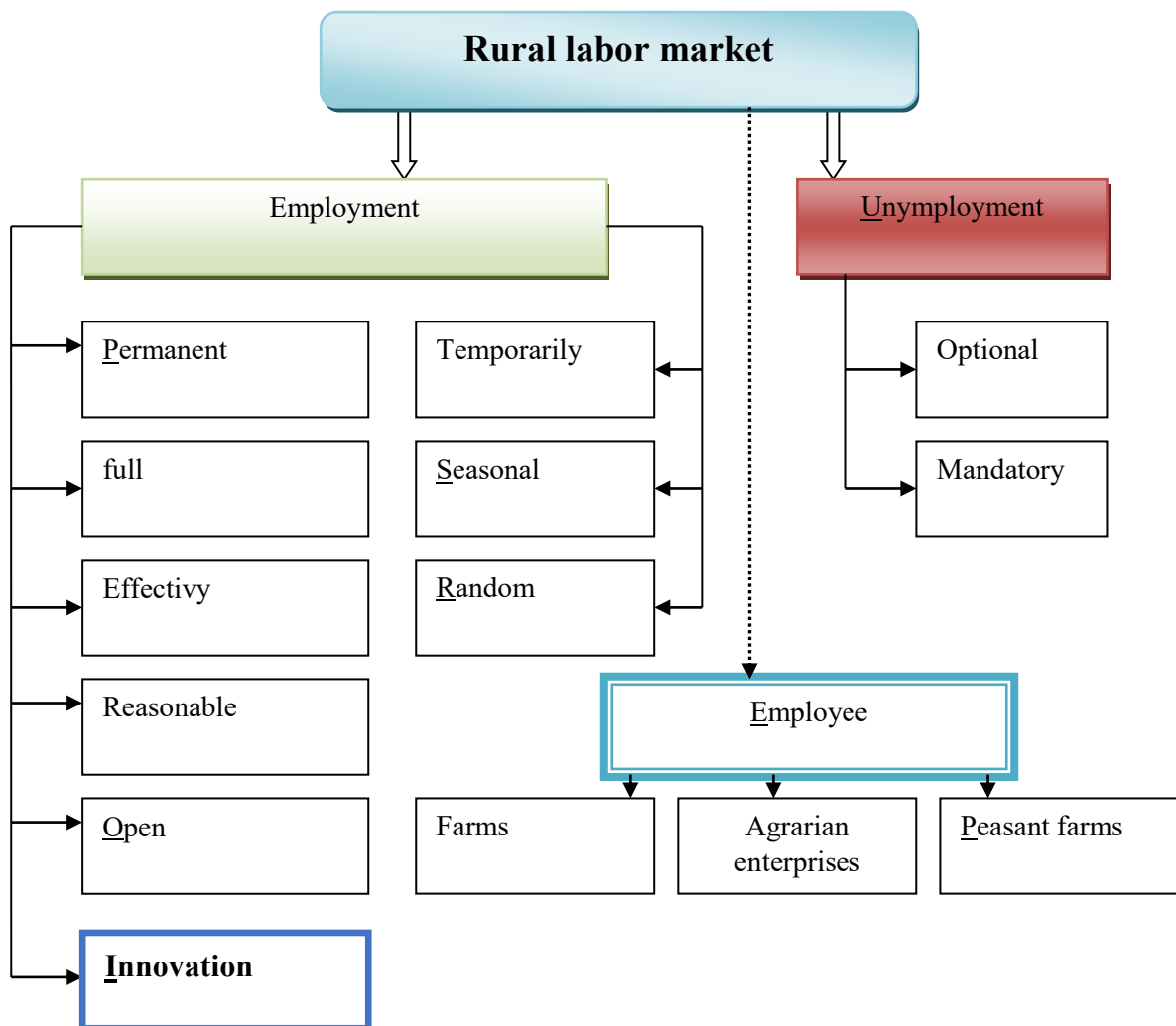

Figure 3. Features of the rural labor market

Source: Developed by the author

"Innovative employment" is an improved form and form of labor activity based on the use of their intellectual abilities by the subjects of the rural labor market and ensuring the achievement of optimal employment.

As a manifestation of new types of employment in the rural labor market, new technologies of job or personnel search, creation of private business, labor mobility, innovative labor contracts, new forms of employment (leasing, employment in social funds, employment in virtual organizations, etc.) .k.); distance learning, direct innovative labor in enterprises, and so on.

World practice shows that there are two ways to build a national innovative economy:

1) **"mastery"** strategy or **"chase"** model. In this type of strategy, the investment policy will be mainly focused on the acquisition of new machinery and equipment, technical and technological re-equipment of production, the technological base of the national economy. As a result, the product will be

competitive in world markets by increasing production rates and reducing costs. Most developing countries in the world have chosen this method;

2) “**Multiplication**” strategy or model of increasing existing scientific potential using its own scientific and technical potential. This model uses investment policy aimed at supporting and developing its scientific base. The country's economic policy, research, and the creation of new goods and services, production and financing of priority.

Uzbekistan has chosen the same second path, transforming the national economy into an innovative model of development, with a high share of innovation and intellectual contribution in production, competitiveness in modern and global markets, rapid development of industry, "smart agriculture", services, as well as a favorable investment and business environment. defined a strategic task of finding a solution. On the basis of the **Action Strategy** for the five priority areas of development of the Republic of Uzbekistan in 2019-2021 to create an effective system of incentives for innovative research, ideas, developments and technologies, development of IT infrastructure, digital technologies, in particular, "Smart Agriculture", "Smart City", "Smart Medicine" ”Are being introduced. To this end, a completely new Ministry of Innovative Development was established [10].

In rural areas for the establishment of modern enterprise for the production of competitive products and above all, well-educated, experienced professionals to prepare.

In this regard, the President Sh.Mirziyoev also affirmed, "Today we have one of the most important issues of the agricultural science and practice away from each other, and in many cases corrupt.

One fact is well known to all: where there is no science and research, there will be no development, no rise, and, in general, the future of any industry.

"Unfortunately, over the last 20 years, we have not paid enough attention to the development of the agricultural sector on the basis of scientific achievements. Due to our negligence, the existing research institutes have fallen into a whirlpool of financial problems." [11]

Turning to the statistics, 8% of all students studying at the bachelor's degree in higher education in the country study in agriculture and water management, 4% in services (Figure 4).

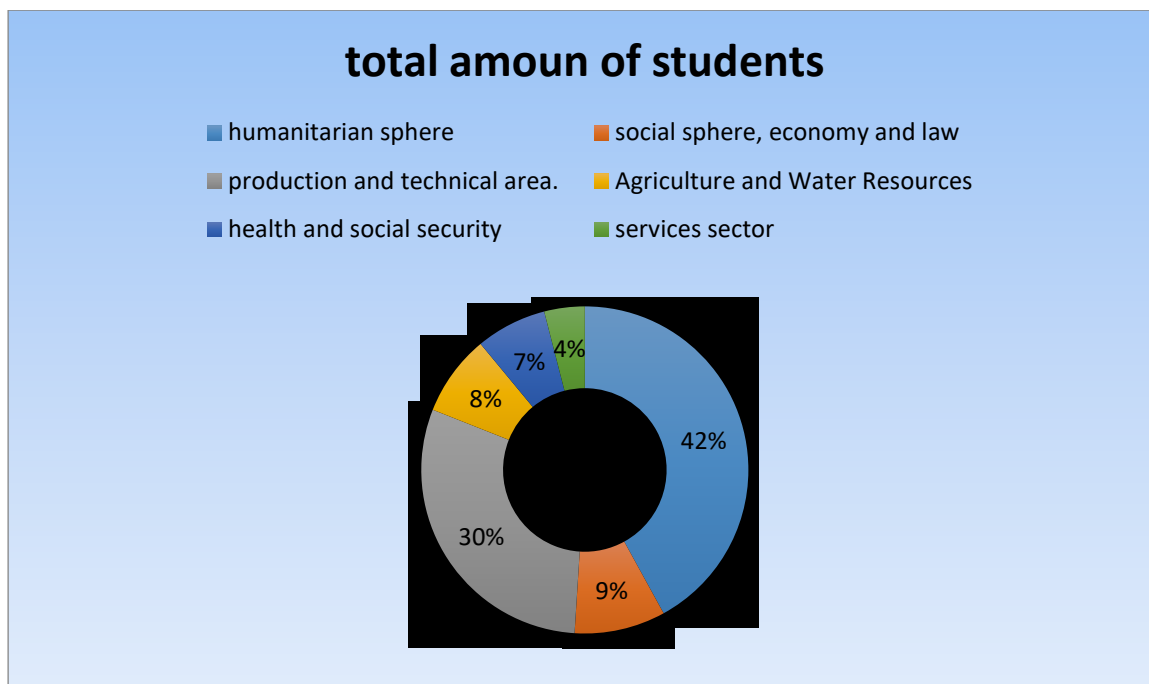

Graph. The total number of students studying at the bachelor's level in the field of study

As can be seen from the above diagrams, in 2019, 5594 graduates of higher education institutions, 1803 in the humanities, 1263 in the social sphere, economics and law, 1431 in production and technology, 668 in health and social care, 312 agriculture and water management, 117 of whom specialize in services. Therefore, in his speech on the newly established Day of Agricultural Workers, Mirziyoyev drew attention to the problem of shortage of staff in the agricultural sector and proposed to transfer from the 2018-2019 academic year to full-time budget grants for master's degree programs in narrow agricultural specialties.

Advances in science and technology are a key process in the production process that increases labor efficiency and leads to staff reductions. In recent years through the production process to increase the level of technical production process to increase the efficiency of labor. First of all, the energy of the production process, technical re-equipment of the enterprise modernization and maintenance activities.

Conclusions and Recommendations

In summary, the rural population, despite the measures taken to increase the level of employment in this sector there are still serious problems. The agricultural sector has a significant impact on the use of labor resources due to its characteristics - seasonality, diversity of agricultural production, the impact of natural factors, the high share of manual labor, etc. At the same time, agriculture is a major consumer of labor due to low labor productivity in the sector, the irrationality of the natural structure of capital.

The population of the rural employment rate is higher than in urban, non-agricultural jobs midst of spring planting, harvest labor shortages, particularly in

FIG. This, in turn, the resuscitation of the supply and demand for manpower in the labor market, as well as the development of regional programs for employment on the basis of the need for effective measures to regulate.

Innovation to improve the level of employment in rural areas is desirable, in our view, the following measures:

- the context of the actual situation in the labor market regions and districts to carry out the analysis, based on the employment of the regions to develop and coordinate the implementation of their programs. At each of the district's internal capacity, taking into account national traditions, natural and geographical location. This is faster and provides the flexibility to the labor market, and does not require spending unnecessary time and costs;

- rural areas is self-employed, flexible forms of employment (part time, weekly, home-based work, home and crafts to expand the family business). This form of jobs to low-cost high results achieved;

- creation of new jobs at the expense of rural areas (financial, tax cuts, interest-free loans, lease additional land, unused capacities and to support other methods). In this case, Uz.R. the legal benefits as part of a wider propaganda and recommended the organization of work;

- to provide employment opportunities for the development of tourism in rural areas is also needed. Today in Kashkadarya region 1 thousand 311 objects of cultural heritage are registered, of which 1 thousand 41 are archeological, 200 are architectural, 43 are sculptures and 27 are monuments. Especially in Kitab, Shakhrisabz, Yakkabag, Guzar and Karshi districts there are many examples of our national heritage. Other districts of the province to increase the tourist areas of tourism, agro tourism, ethnographic tourism, hotel and service opportunities, tourist routes and protected areas in the region to improve the level of international standards, effective use of available opportunities, the development of eco-tourism, Mubarak, Mirishkor district steppes time, such as the organization of a number of projects should be implemented;

- Establishment of permanent cooperation between scientists, specialists of higher education institutions and research centers in this field, the use of their experience. As a result of the development of innovations, it is necessary to train new engineers-chemists entering the rural labor market, production technology, specialists working with equipment for biofuel production, installation of solar panels and batteries, botany, landscape design, installation of wind generators. The demand for these specialists is high in rural areas;

- Funding from the state budget or the provision of soft loans to enterprises and organizations that increase scientific development and train highly qualified personnel;

- Issuance of state orders to agricultural enterprises on a contractual basis for the implementation of research and development;

- Formation of special innovation centers in rural areas - techno parks, technopolises, business incubators, regional innovation funds.

We can see from the experience of the world, the creation of an innovative economy in the world in a single model. States have chosen their own development model of transition to the economy based on their capabilities. Even in developed countries, the transition to an innovative economy has not taken place in a short period of time. Therefore, there is no doubt that the innovative way of developing the economy of Uzbekistan will be a driving force of the country's competitiveness, a factor in improving the welfare of the population, employment.

Bibliography:

1. The President of the Republic of Uzbekistan Shavkat Mirziyayev the country's socio-economic development in 2018 and the most important priorities of economic program for 2019, the results of the meeting of the Cabinet of Ministers extended //s words, January 16, 2019, №11 (6705).
2. "The strategy for the further development of the Republic of Uzbekistan" On February 7, 2019, the President of the Republic of Uzbekistan No. UP-4947 Decree, Annex 1, paragraph 4.1.
3. Loktyukhina N.V. Some scientific basis of the labor market and employment theory // Man and labor, 2010, number 4. P.75.
4. Nikiforov A.A. Labor market: employment and unemployment. –M.: International relations, 1999. P.89.
5. Abdurahmonov K.X. Labor economics and sociology. – T .: Science and technology, 2012. P.89
6. Kholmuminov Sh.R., Arabov N.U. Labor market infrastructure. Study guide. –T .: “Science and technology”, 2016. 71-72 p
7. Ehrenberg R.D., Smith R.S. Modern Labor Economics: Theory and Public Policy. -M .: Moscow State University, 1996.S. 54.
8. Kotlyar A.E. Theoretical and methodological problems of the labor market and employment // Labor market and employment: modern problems of theory and practice. Series: "Point of View". - M .: RAGS, 2004. P.41.
9. Amanov O.A. The main directions of modernization of the rural labor market. Monograph. - Tashkent: “Science and technology”, 2014. P.77.
10. Decree of the President of the Republic of Uzbekistan dated November 29, 2017 "On the establishment of the Ministry of Innovative Development of the Republic of Uzbekistan" // Collection of Legislation of the Republic of Uzbekistan, December 4, 2017, No. 48, Article 1179
11. [http://president.uz/uz/lists/view/1331-Sh.M.Mirziyoev's speech at the solemn ceremony dedicated to the Day of Agricultural Workers](http://president.uz/uz/lists/view/1331-Sh.M.Mirziyoev's%20speech%20at%20the%20solemn%20ceremony%20dedicated%20to%20the%20Day%20of%20Agricultural%20Workers)
12. Statistical Bulletin of the Republic of Uzbekistan. Tashkent -2020.
13. Kh, Abdurakhmanov K., et al. "Labor migration and its impact on employment of population." *Международный научно-исследовательский журнал* 4-2 (82) (2017). URL: <https://research-journal.org/economical/labor->

migration-and-its-impact-on-employment-of population/ doi:10.23670/
IRJ.2017.82.4.028

14. Amanov O.A. Ways of regulation, condition and employment trends of the population of the republic of Uzbekistan. Journal of Management Value & Ethics. India. ISSN: 2249-9512 Vol 8, №2, 2018.–P.98-106. URL: https://www.jmveindia.com/journal/APRIL-JUNE_18.pdf

*Абакаров Ш.М.
студент
Уральский институт управления – филиал РАНХиГС*

ОСНОВНАЯ ПРОБЛЕМА В ЗДРАВООХРАНЕНИИ РФ

Аннотация. В настоящей статье рассмотрена основная проблема в сфере здравоохранения Российской Федерации, а именно кадровый дефицит, а также причины, ведущие к этому.

Ключевые слова: здравоохранение, проблемы здравоохранения, медицина, врачи, кадровый дефицит в здравоохранении.

*Abakarov Sh.M.
student
Ural Institute of Management - branch of RANEPA*

THE MAIN PROBLEM IS IN THE HEALTH CARE OF THE RUSSIAN FEDERATION

Summary. This article examines the main problem in the health sector of the Russian Federation, namely the personnel deficit, as well as the reasons leading to this.

Key words: healthcare, health problems, medicine, doctors, personnel shortages in healthcare.

Здравоохранение - совокупность мер политического, экономического, социального, правового, научного, медицинского, санитарно-гигиенического, противоэпидемического и культурного характера, направленных на сохранение и укрепление физического и психического здоровья каждого человека, поддержание его долголетней активной жизни, предоставление ему медицинской помощи в случае ухудшения здоровья.

Согласно Конституции РФ, «Российская Федерация - это социальное государство», в котором «каждый имеет право на охрану здоровья и медицинскую помощь».

Закрепляя это право в Конституции, государство принимает на себя обязанность осуществлять целый комплекс мер, направленных на устранение в максимально возможной степени причин ухудшения здоровья населения, предотвращение эпидемических, эндемических и других заболеваний, а также на создание условий, при которых каждый человек может воспользоваться любыми незапрещенными методами лечения и оздоровительными мерами для обеспечения наивысшего достижимого на современном этапе уровня охраны здоровья.

По данным Министерства здравоохранения Российской Федерации не хватает более 148 тысяч старшего медицинского персонала и более 800 тысяч среднего медицинского персонала. При этом нужно брать во внимание то, что 40% старшего медицинского персонала находится в предпенсионном и пенсионном возрастах. В результате нагрузка врачей на амбулаторном приеме существенно увеличивается и страдает качество. Это подтверждено результатами исследований в университете Джонса Хопкинса (2013), где было научно доказано, что чрезмерные нагрузки на врачей не способствуют безопасности пациентов и приводят к более низкому качеству лечению, а это только увеличивает расходы на здравоохранение.

Основные проблемы, с которыми люди сталкиваются при обращении в медицинское учреждение:

- Длинные очереди на приём к специалисту.
- Отсутствие необходимых специалистов.
- Отсутствие талонов к нужному специалисту.

Каждая из вышеперечисленных проблем обусловлена дефицитом медицинских кадров.

«Одна из причин такого положения — низкие зарплаты» - считает ректор Высшей школы организации и управления здравоохранением Гузель Улумбекова.

Средняя зарплата врачей в РФ на 22 % ниже, чем средняя заработная плата по стране. В то время как в странах ЕС врач получает в 1,5–2,5 раза больше средней заработной платы. «Для сравнения, в Германии средняя зарплата врача более чем в 2 раза выше среднего уровня заработной платы по стране, в США – в 5 раз» – рассказала Ксения Медведева, руководитель департамента исследований в медицине и фармацевтике MAR CONSULT.

Неудовлетворенность заработной платой высказывают более 55 % старшего медицинского персонала; 80 % врачей уходят из медицины из-за низкой зарплаты. Согласно указу Президента Российской Федерации от 07.05.2012 г. №597 О мероприятиях по реализации государственной социальной политики России поставлена задача – повышение к 2018 году средней заработной платы среднего медицинского персонала до 100 процентов от средней заработной платы в соответствующем регионе, старшего медицинского персонала до 200 процентов от средней заработной платы в соответствующем регионе. Однако при этом не уточняется, на сколько ставок будет работать врач. Сейчас работа врачей первичного звена оплачивается ниже, чем в среднем по стране. Специалисты, работая на полторы или две ставки, получают не более 40 тыс. руб. — это зависит от региона.

В ходе исследования, проведенного Титовой Е.Я. и Коновалова Н.В., отмечено превышение норм рабочей нагрузки у 47 % медсестер за счет внутреннего совместительства, у 19 % – за счет внешнего совместительства,

у 35 % – за счет сверхнормативных дежурств. При этом 59 % медсестер отмечают хроническое недосыпание. Длительность ночного сна составляет менее шести часов у 12 % опрошенных. Одна из основных причин повышенных нагрузок – низкая заработная плата.

По мнению Л. М. Рошалья, указ президента Российской Федерации Владимира Владимировича Путина об увеличении заработной платы медицинским работникам привел не к увеличению государственных расходов на заработную плату, а к придуманной финансистами «оптимизации» со всеми негативными последствиями. В стране острый кадровый дефицит: не хватает медицинского персонала в первичном звене, не хватает узких специалистов. И «оптимизация» не решила кадровую проблему. Отсюда и невозможность получить лечение вовремя.

Более 30 % населения страны оценивают престиж медицинских специальностей как низкий. А из числа старшего медицинского персонала только 20 % оценивают свой статус как высокий. Низкая престижность профессии врача в России в большей мере является следствием низкой оплаты труда медработников.

Учитывая особую остроту проблемы укомплектования медицинскими кадрами государственных и муниципальных медицинских организаций нужно обеспечить выполнение указа Президента Российской Федерации о повышении средней заработной платы медицинского персонала фактически, а не только «на бумаге».

Использованные источники:

1. Федеральный закон от 21.11.2011 № 323-ФЗ (ред. от 29.07.2017) «Об основах охраны здоровья граждан в Российской Федерации».
2. Конституция Российской Федерации (принята всенародным голосованием 12 декабря 1993 года с изменениями, одобренными в ходе общероссийского голосования 1 июля 2020 года.) (с учетом поправок, внесенных Законами РФ о поправках к Конституции РФ от 30.12.2008 № 6-ФКЗ, от 30.12.2008 № 7-ФКЗ, от 05.02.2014 № 2-ФКЗ, от 21.07.2014 № 11-ФКЗ, от 14.03.2020 года № 1-ФКЗ.).
3. Комаров Ю. О подготовке врачебных кадров в Российской Федерации // Медицина. – 2013. – № 3. – С. 1–11.
4. Костин А.А., Пономаренко Б.Т., Самсонов Ю.В. Государственная кадровая политика в сфере здравоохранения: научное издание. – М.: Международный издательский центр «Этносоциум», 2015. – 96 с.
5. Отставных Д.В. Проблемы кадрового обеспечения отрасли здравоохранения в современных условиях // Вестник общественного здоровья и здравоохранения Дальнего Востока России. – 2012. – Т. 9, № 4. – С. 5.
6. Рошаль Л.М. Дефицит медицинских кадров – это общероссийская проблема [Электронный ресурс] // MEDR USSIA. URL:

<https://medrussia.org/7549-deficit-medicinskikh-kadrov/> (дата обращения: 08.12.2020)

7. Савинкина Л.А., Шепелова Т.С. Проблемы дефицита медицинских кадров и пути их решения //Современные проблемы науки и образования. – 2014. – № 6. – С. 569.

8. Титова Е.Я., Коновалова Н.В. О некоторых аспектах управления здоровьем персонала // Проблемы экономики, организации и управления в России и мире: материалы VI Международной научно-практической конференции. – Прага: Изд-во WORDLPRESSsr.o., 2014. – С. 224–225.

*Абдурахманова А.М.
студент группы 333ЮМ
факультет юриспруденция
РАНХиГС
Россия, Ростов-на-Дону*

НОРМАТИВНО-ПРАВОВОЕ РЕГУЛИРОВАНИЕ ВЗЫСКАНИЯ НАЛОГОВОЙ ЗАДОЛЖЕННОСТИ В СОВЕТСКИЙ ПЕРИОД

Аннотация: Статья посвящена исследованию особенностей нормативно-правового регулирования взыскания задолженности по налоговым платежам в советский период. Исследованы нормативно-правовые акты, принятые в СССР в период с 1923 по 1990-е годы, определяющие порядок взыскания налоговой недоимки. Определены особенности бесспорного и судебного порядка взыскания.

Ключевые слова: налоговая задолженность, недоимка, взыскание, бесспорный порядок, механизм взыскания

*Abdurakhmanova A.M.
student of group 333YUM
Faculty of law
Ranepa
Russia, Rostov-on-don*

LEGAL REGULATION OF TAX DEBT COLLECTION IN THE SOVIET PERIOD

Abstract: the Article is devoted to the study of the features of legal regulation of debt collection for tax payments in the Soviet period. The article examines the legal acts adopted in the USSR in the period from 1923 to the 1990s, which determine the procedure for collecting tax arrears. The features of the undisputed and judicial order of recovery are determined.

Keywords: tax arrears, arrears, recovery, undisputed procedure, recovery mechanism

Сфера взыскания задолженности по налогам и нормативные акты, регулирующие ее, развивались последовательно вместе с развитием налогообложения и формированием налоговой системы. Налоговая система России имеет длительную историю и в своем развитии прошла несколько сложных этапов. В этом аспекте налоги являются важной частью российской истории. В результате двух революций 1917 года в России – Февральской и Октябрьской – произошло изменение политического курса,

а также существенно изменена налоговая система. Основным доходом молодого советского государства были эмиссия денег, контрибуция и продразверстка, а также чрезвычайные налоги [8, с. 27].

В 1920–е годы не существовало законов, которые могли бы взыскать с должника всю сумму долга. Поэтому в период НЭПа коммерческая деятельность населения и организаций часто характеризовалась «невозвратными долгами». Механизм взыскания долгов определяла ст. 271 ГПК РСФСР 1923 года [7], которая содержала множество исключений, при которых запрещалось изъятие определенного имущества при взыскании долга. Такое исключение составляли, например, орудия сельского хозяйства, скот, корм для скота, семена для посева, не снятый урожай.

В 1924 – 1925 годах в этот перечень вошли паевые взносы должника в потребительский кооператив, взносы в сельскохозяйственные кооперативы, страховое вознаграждение по договору страхования. Учитывая уровень жизни населения того периода перечень этот был более чем внушительный. В результате имеющиеся механизмы взыскания долгов не работали, взыскивать было просто нечего. Взысканием по исполнительным листам занимались судебные исполнители НКЮ и НКВД.

В 1925 году они получили право прекращать исполнительное производство, если местонахождение должника было неизвестно или если у должника не оказывалось имущества, которое можно было бы взыскать [6].

Ситуация кардинально изменилась в 1929 году, когда был принят Циркуляр Наркомфина СССР и Россельбанка, который позволил досрочно взыскивать долги с зажиточных крестьян и кулаков [5]. При желании к этим категориям мог быть отнесен любой нарушитель. Согласно документу, вся задолженность должны быть ликвидирована в кратчайшие сроки. К злостным должникам применялись меры взыскания через судебные органы. Этот циркуляр фактически сделал равными неуплату долгов и преступление.

В 1930–1932 гг. в СССР полностью упразднили акцизы. Кроме того, почти 60 прямых налогов с предприятий сократили до двух платежей – налог с оборота и отчисления от прибыли. Некоторые налоги с населения также были сокращены – большинство из них отменили. В то же время был установлен налог с оборота кинотеатров, который затем был объединен с налогом со зрелищ. Такие изменения в системе налогов отразились на системе их взыскания.

В 1932 году вышло Положение о взыскании налогов и неналоговых платежей [4]. В соответствии с ним принудительно могли быть взысканы налоговые и неналоговые платежи в общегосударственный и местный бюджеты, платежи по самообложению и по обязательному государственному страхованию. Плательщиками были учреждения, предприятия, организации обобщественного сектора, частные

предприятия, граждане, кулацкие хозяйства, а также облагаемые подоходным налогом лица.

Платежи взыскивались органами, которые их исчисляли или непосредственно наблюдали за их уплатой. Органами взыскания были народные комиссариаты финансов, а координирующим их органом – Народный комиссариат финансов СССР. Им оказывали помощь милиция, домоуправления, рабочие бригады.

Объектами взыскания налоговой задолженности учреждений, предприятий, организаций могли стать наличные деньги из кассы, денежные документы, расчетные или текущие счета в кредитном учреждении, товары и иное имущество, выданные кредитным учреждением аккредитивы, открытые особые счета, суммы бюджетного финансирования.

Мерами взыскания налоговой задолженности учреждений, предприятий, организаций были арест наличных денежных средств и их последующее изъятие, списание со счета, арест товаров и их последующая продажа, арест аккредитивов и особых счетов, погашение за счет бюджетного финансирования. Имущество недоимщика продавалось через предприятия и организации обобщественного сектора или с публичных торгов. 11 апреля 1937 г. появилась возможность судебного взыскания налогов с граждан[3].

Порядок взыскания налоговой задолженности, установленный в 1930–х годах, практически без изменений действовал до 1980 года. С 1981 года введен новый порядок взыскания налоговой задолженности[2].

Была существенно расширена система органов, взыскивающих налоговую задолженность. Налоговая задолженность взыскивалась налоговыми органами, исполнительными комитетами поселковых и сельских Советов народных депутатов, органами государственного страхования, органами профессиональных союзов, государственными налоговыми инспекциями.

Также существовала система руководства работой по взысканию налоговой задолженности. Ее составляли ВЦСПС – взыскивал взносы по государственному социальному страхованию; Министерство финансов СССР – по взысканию всех остальных платежей.

Невнесенная сумма рассматривалась в качестве недоимки и на нее начислялась пеня после истечения установленного срока уплаты соответствующего платежа. Налоговая задолженность погашалась в следующем порядке: сначала погашалась недоимка, потом – пеня. При взыскании недоимки первоначально покрывались затраты на ее взыскание. Недоимки по платежам взыскивались в бесспорном порядке на основе распоряжения соответствующих органов. При отсутствии денежных средств взыскание недоимки обращалось на любое имущество должника.

Налоговая задолженность в советский период в бесспорном порядке могла быть взыскана только с советских и иностранных предприятий,

учреждений, организаций, но не с граждан. С граждан СССР, лиц без гражданства, иностранных граждан недоимки взыскивались только по решению суда.

До подачи в суд заявления о взыскании недоимки органы взыскания налагали арест на имущество недоимщика. Арест имущества включал в себя следующие действия: описание имущества, объявление недоимщику запрета на распоряжение описанным имуществом, вручение предупреждения о передаче дела в суд. Последнее могло иметь место, когда недоимка не погашалась в течение 10 дней после ареста имущества. Имущество описывали обязательно в присутствии недоимщика и двух понятых. Об описи имущества составляется акт установленной формы. Описанное имущество хранилось у недоимщика. Если последний отказывался – другому лицу по усмотрению органа взыскания.

Заявление о взыскании недоимки подавалось в суд. При рассмотрении судом дела был возможен перерасчет платежа органом взыскания. Было возможно обращение взыскания на все виды заработка, пенсию, стипендию недоимщика, но не более 20% от суммы.

Эпоха перестройки середины 1980–х годов вызвала необходимость изменения налоговой системы. В 1990 г. был принят Закон «О налогах с предприятий, объединений и организаций» [1] – первый унифицированный нормативный акт в налоговой сфере. Статья 38 названного закона определила порядок, в соответствии с которым могли быть взысканы в бюджет или возвращены из бюджета неправильно уплаченные налоги. Налоговую задолженность составляли не внесенный в установленные сроки налог с оборота, а также налог с иного сокрытого объекта налогообложения и сокрытая прибыль. Порядок взыскания был бесспорный. При взыскании начислялась пеня – 0,2% от суммы недоимки за каждый день просрочки (включая день уплаты).

Таким образом, система взыскания налоговой задолженности стала развиваться вместе с налоговой системой, системой органов, занимающихся взиманием налогов, а также системой наказаний за неуплату налогов и пошлин. Полноценное развитие системы взыскания налоговой задолженности и правовых актов ее определяющих началось только в советский период, когда в 1932 году было принято первое соответствующее положение. В целом определенный в 1930–х годах порядок взыскания налоговой задолженности действовал до 1981 года. С 26 января 1981 года было принято новое положение и начал действие новый порядок взыскания не внесенных в срок налогов и неналоговых платежей. Была существенно расширена система органов, взыскивающих налоговую задолженность и система руководства работой по взысканию налоговой задолженности. Недоимки по платежам взыскивались в бесспорном порядке на основе распоряжения соответствующих органов. В 1990 г. Закон СССР N1560–I «О налогах с предприятий, объединений и организаций» также закрепил

беспорный порядок взыскания налоговой задолженности, которая взыскивалась за все время уклонения по распоряжению налогового органа. Итак, в конце советского периода сложился полноценный порядок принудительного взыскания налоговой задолженности с советских предприятий и граждан, а также система органов, осуществляющих такое взыскание.

Использованные источники:

1. Закон СССР N1560–I «О налогах с предприятий, объединений и организаций» от 14 июня 1990 года №1560–1 (утратил силу) // Ведомости СНД СССР и ВС СССР. 1990. №27. Ст. 522.
2. Указ Президиум Верховного Совета СССР от 26 января 1981 года №3820–X «Об утверждении положения о взыскании не внесенных в срок налогов и неналоговых платежей» (утратил силу) // Ведомости СНД СССР и ВС СССР. 1981. №3.
3. Постановление ЦИК и СНК СССР от 11 апреля 1937 г. «Об отмене административного порядка и установление судебного порядка изъятия имущества в покрытие недоимок по государственным и местным налогам, обязательному окладному страхованию, обязательным натуральным поставкам и штрафам, и с колхозов, кустарно–промысловых артелей и отдельных граждан» (утратило силу) // Собрание законодательства СССР. 1937. №30. Ст. 120.
4. Положение о взыскании налогов и неналоговых платежей, утвержденное Постановлением ЦИК и СНК СССР от 17 сентября 1932 г. (утратило силу) // Собрание законодательства СССР. 1932. №69. Ст. 410–б.
5. Циркуляр Наркомфина СССР и Россельбанка «О досрочном взыскании ссуд с кулацких и зажиточных хозяйств». 12–13 января 1930 г. (утратил силу) // Советская юстиция. 1930. №6. С. 30.
6. Циркуляр Наркомюста РСФСР от 26.04.1926 №76 «Список циркуляров НКЮ за 1922 – 1925 гг. (утратил силу) // Сборник циркуляров Наркомюста РСФСР за 1922 – 1925 гг. М., 1926.
7. Постановление ВЦИК от 10.07.1923 (утратил силу) «О введении в действие Гражданского Процессуального Кодекса Р.С.Ф.С.Р.» (вместе с «Гражданским Процессуальным Кодексом Р.С.Ф.С.Р.») // Собрание узаконений РСФСР. 1923. №46 – 47. Ст. 478.
8. Актуальные проблемы финансового и налогового права. Учебное пособие / отв. ред. Карасева М.В. М.: Проспект, 2020. С. 27.

*Абдурахманова А.М.
студент группы 333ЮМ
факультет юриспруденция
РАНХиГС
Россия, Ростов-на-Дону*

ЭКОНОМИКО–ПРАВОВОЕ ЗНАЧЕНИЕ НАЛОГОВОЙ ЗАДОЛЖЕННОСТИ

Аннотация: Статья посвящена исследованию экономико-правовой сущности налоговой задолженности. В статье определено понятие, состав и виды налоговой задолженности, ее урегулирование, рассмотрены категории урегулированной и неурегулированной налоговой задолженности, выявлены факторы формирования налогового поведения налогоплательщиков, следствием которых является образование налоговой задолженности.

Ключевые слова: задолженность, налоговая задолженность, урегулирование, механизм взыскания

*Abdurakhmanova A.M.
student of group 333YUM
Faculty of law
Ranepa
Russia, Rostov-on-don*

ECONOMIC AND LEGAL SIGNIFICANCE OF TAX ARREARS

Abstract: the Article is devoted to the study of the economic and legal nature of tax debt. The article defines the concept, composition and types of tax debt, its settlement, considers the categories of settled and unsettled tax debt, identifies the factors of formation of tax behavior of taxpayers, the consequence of which is the formation of tax debt.

Keywords: debt, tax debt settlement, a mechanism for the recovery

В условиях сложной политической, экономической и эпидемиологической ситуации в России особое значение приобретают регулирования взыскания налоговой задолженности. Налоговая задолженность существенно ограничивает объем финансовых (бюджетных) ресурсов государства, что является глобальной проблемой, дестабилизирующей экономику. Налоговая задолженность составляет существенную проблему не только для государства, но также для органов местного самоуправления, организаций, физических лиц. Налоговая

задолженность – негативный экономический фактор. Ее ежегодный рост означает наличие серьезной проблемы, ограничение объема финансовых ресурсов, снижение возможностей решения социальных проблем.

В России на начало 2019 года общая сумма налоговой задолженности составила 1 031 693 514 руб., из нее пени по налоговым санкциям 348 015 544 руб. Рост налоговой задолженности первой группы в сравнении с началом 2018 года составил 24,69%, а второй группы – 17,26% [8]. Следовательно, для Российской Федерации наиболее характерной является проблема налоговой задолженности. Поэтому необходимо совершенствование имеющихся правовых мер, направленных на предупреждение, предотвращение образования, а также взыскания налоговой задолженности.

Урегулирование налоговой задолженности – составная часть активно развивающегося сейчас налогового администрирования. Налоговая задолженность образуется после неуплаты текущих налоговых платежей; проведения мероприятий налогового контроля, выявления в ходе них задолженности и до начисления уплаченных налогов. По НК РФ[1] налогоплательщик или налоговый агент должен осуществлять уплаты (перечисление) суммы налога в установленные сроки. Но данное условие выполняется не всегда, что влечет за собой ряд налоговых санкций: пени; штраф (ст. 122 НК РФ); взыскание недоимки, пеней и штрафов (п. п. 2, 8 ст. 45 НК РФ).

Недоимка является основной суммой задолженности по какому-либо налогу или по нескольким налогам. В структуру налоговой задолженности могут входить суммы недоимки, неуплаченные суммы процентов, пени, налоговые санкции. Основаниями начисления недоимки являются:

- налоговая отчетность налогоплательщика;
- не оспоренное налогоплательщиком решение органа налоговой службы;
- в случае спора - решение суда.

Налоговая задолженность отличается следующими характерными чертами: возникновение после не выполнения налогового обязательства; необходимость ее погашения в определенный срок; денежная форма[7, с. 9].

В зависимости от подтверждения налоговая задолженность также может быть подтвержденная и скрытая[2, с. 38]. В первом случае налоговая задолженность документально фиксируется и подтверждается налогоплательщиком и налоговым органом. Во втором случае налоговая задолженность – факт неуплаты налогоплательщиком налогов – не отражен в налоговой отчетности.

Наиболее часто используются понятия урегулированной и неурегулированной задолженности. Урегулированной является задолженность, к которой применены методы урегулирования. К ним относятся:

- задолженность налогоплательщика, находящегося в состоянии банкротства;
- задолженность, взысканная в бесспорном порядке;
- отсрочка или рассрочка налогового платежа;
- приостановление мер взыскания до принятия решения судом или налоговым органом;
- реструктуризация налогового платежа.

Неурегулированной является выставленная налогоплательщику недоимка, но еще не уплаченная налогоплательщиком, а также невозможная к взысканию задолженность. Наличие показателя неурегулированной задолженности в консолидированном бюджете является отрицательным фактором. Напротив, взыскание налоговой задолженности способствует росту доходной части бюджетов. Поэтому нужны меры для развития системы ее взыскания, а также для выявления причин определения социально-экономических последствий ее образования, сохранения размеров и роста[4, с. 16].

По мнению специалистов, современная налоговая служба не располагает однозначными методами, которые способны эффективно противостоять налоговой задолженности. Налоговым органам вначале нужно осуществить анализ реальной платежеспособности налогоплательщика, то есть определить реальные возможности налогоплательщика, по погашению имеющейся у него в наличии задолженности. Государством должны создаваться все условия по интенсификации уплаты налогов без ущерба для налогоплательщика. В результате чего система взыскания налоговой задолженности станет существенно упрощенной[5, с. 207].

ФНС РФ при взыскании налоговой задолженности ежедневно сталкивается с определенными проблемами. Такие проблемы определяются не совершенной процедурой административного порядка ее взыскания. В связи с этим такой порядок нужно существенно реформировать. ФНС РФ должна производить оценку реальной платежеспособности налогоплательщика. Также нужно устранить противоречия налогового законодательства, более точно детализировать права и обязанности налогоплательщика и налогового органа и повышать качество налогового контроля введением новых программных комплексов. Все это повысит взыскание налоговой задолженности[6, с. 127.].

В большинстве случаев предприятия сталкиваются с определенными трудностями в бизнес-деятельности, в результате которых они теряют способность выполнять текущие налоговые обязательства, что приводит к задержке выполнения таких обязательств и формированию значительной задолженности по налогам. Причиной возникновения таких трудностей становится ухудшение экономической ситуации на предприятии в течение значительного периода.

Факторами формирования налогового поведения налогоплательщиков являются следующие:

- способность – знание налогоплательщиком и понимание налоговых правил и своих налоговых обязательств;
- мотивация – готовность налогоплательщика соблюдать налоговые правила и налоговые обязательства;
- возможность налогоплательщика выполнять налоговое обязательство[3, с. 36].

В соответствии с этими факторами определяются две причины формирования у налогоплательщиков налоговой задолженности: не организованы процессы по расчету и уплате налогов; нет возможности заплатить. В последнем случае имеют место факторы, не подконтрольные бизнесу и негативно влияющие на его способность своевременно выполнять налоговые обязательства – развивающийся экономический кризис, влияющий на движение денежных средств, длительные и продолжающиеся просрочки платежей должников, безнадежные долги после банкротства контрагентов–дебиторов, ужесточение финансовыми организациями условий кредитования и овердрафта. В современных условиях в работе с налогоплательщиками необходим индивидуальный подход, так как в условиях пандемии и карантинных мер многие из них испытывают трудности с движением денежных средств, а управление налоговой задолженностью может в этом эффективно помочь, например, положительный эффект могут иметь поэтапные выплаты обязательных платежей.

Урегулирование и взыскание налоговой задолженности существенно различаются. Урегулирование налоговой задолженности является элементом налогового администрирования и включает в себя разные методы поддержки налогоплательщиков. Взыскание налоговой задолженности обеспечивает исполнение налогоплательщиками их обязанности по уплате налогов.

Порядок и особенности взыскания налоговой задолженности определяется налоговой политикой страны. Механизм взыскания общей налоговой задолженности – универсальный показатель ее снижения. Его главная черта – системность действий по взысканию. Специфичность системы взыскания налоговой задолженности определяет неравенство субъектов налоговых отношений – налогоплательщиков и налоговых органов.

Таким образом, урегулирование налоговой задолженности является важной составляющей финансовой сферы государства. В структуру налоговой задолженности наряду с недоимкой могут входить суммы недоимки, неуплаченные суммы процентов, пени, налоговые санкции. Налоговая задолженность может быть классифицирована в зависимости от подтверждения, в зависимости от причины возникновения типов налоговых

неплательщиков, в зависимости от урегулирования. Факторами формирования налогового поведения налогоплательщиков являются следующие: способность, мотивация, возможность налогоплательщика выполнять налоговое обязательство.

Использованные источники:

1. Джумабаева Г.Б. Налоговая задолженность: виды и пути снижения на современном этапе // Научные вести. 2020. №5.
2. Зубарева Е.В., Борисова Э.Н. Управление налоговой задолженностью экономических субъектов // Фундаментальные исследования. 2020. №4.
3. Налоговый Кодекс Российской Федерации (часть первая) от 31.07.1998 №146–ФЗ (ред. от 15.10.2020 №335–ФЗ) // Собрании законодательства Российской Федерации. 1998. №31. Ст. 3824; Российская газета. 2020. №267.
4. Польская Г.А. Теоретические аспекты управления налоговой системой на современном этапе // Таврический научный обозреватель, 2017. №11–2.
5. Рысляева Е.И. Актуальные проблемы взыскания налоговой задолженности // Трибуна ученого. 2020. №4.
6. Семин Д.Ю. Анализ динамики и структуры задолженности по налогам и сборам, пеням и налоговым санкциям в РФ за 2015–2019 гг. // Вестник Алтайской академии экономики и права. 2020. №4–1.
7. Содномова С.К., Маркевич В.В. Пени и штрафы как составляющие налоговой задолженности: сходства и различия // Global and Regional Research. 2019. Т. 1. №2.
8. Статистика и аналитика Федеральной налоговой службы [Электронный ресурс]. – Режим доступа: URL:https://www.nalog.ru/statistics_and_analytics/forms (дата обращения: 15.09.2020).

*Абдурахмонов А.
старший преподаватель
Сайпиддинов Ш.
старший преподаватель
Наманганский инженерно-технологический институт
Узбекистан, Наманган*

РЕНТАБЕЛЬНОСТЬ, ПОЛУЧЕННАЯ ОТ ИСПОЛЬЗОВАНИЯ ХЛОПКО ОЧИСТКИ В ПРОИЗВОДСТВЕ

Аннотация: Одна из основных задач, стоящих перед переработчиками в статье, - повышение эффективности производства за счет модернизации оборудования, выпуска продукции высокого качества, обеспечения конкурентоспособности, сокращения отходов и увеличения ассортимента выпускаемой продукции.

Ключевые слова: Хлопко-очистка, стирка, сырье, сорт, сорт, стоимость, режим работы, оборудование.

*Abdurakhmonov A.
senior lecturer
Saypiddinov Sh.
senior lecturer
Namangan Engineering and Technological Institute
Uzbekistan, Namangan*

PROFITABILITY DERIVED FROM THE USE OF CLEANING COTTON IN PRODUCTION

Abstract: One of the main tasks facing converters in the article is to increase production efficiency by upgrading equipment, producing high quality products, ensuring competitiveness, reducing waste and increasing the range of products.

Key words: Cotton cleaning, washing, raw materials, grade, grade, cost, operating mode, equipment.

Среди хлопка-сырца, получаемого переработчиками, есть определенное количество некачественного хлопка, из которого производится некачественное хлопковое волокно. Повышение эффективности производства - важнейшая задача любого предприятия. Он представляет собой качественные и количественные показатели управления, а также взаимосвязь между затратами на упакованный и живой труд и полученными результатами.

В рыночной экономике понятие "эффективность" используется реже, чем понятия цены, прибыли, дохода, затрат, хотя оно не противоречит требованиям рыночной экономики, хотя доход, снижение затрат, рост производительности труда, доходность фондов, прибыльность и т. Д. Соответствуют природе эффективности. Эффективная производительность означает, по сути, получение запланированной (запланированной) прибыли, сокращение непроизводственных затрат и потерь, более эффективное использование производственных мощностей и рабочей силы, повышение производительности труда, улучшение качества выпускаемой продукции.

Результативность - это положительные результаты деятельности предприятия, связанные с увеличением объема продукции (работ, услуг), прибыли и выручки, снижением себестоимости продукции, сокращением или прекращением выпуска некачественной продукции. Эти достижения характеризуют эффективность производства в натуральной форме и экономическую эффективность в денежной форме.

Осуществление процессов технической и технологической модернизации на предприятиях будет направлено на улучшение их результатов, обеспечение более быстрого развития за счет повышения эффективности производственного процесса. В современных рыночных отношениях любая деятельность направлена на повышение конкурентоспособности. Это требует большего внимания к качеству продукции. Хлопковое сырье, полученное переработчиками, имеет различные загрязнители. Если их очистить от примесей, они переходят в более высокий класс, а значит, улучшается качество. Созданное нами устройство представляет собой хлопковое сырье 4-го сорта 2-го сорта для 4-го сорта 1-го сорта, хлопковое сырье 3-го сорта 2-го сорта для 3-го сорта 1-го сорта, хлопковое сырье 2-го сорта 2-го сорта для 2-го сорта 1-. позволяет перейти в класс.

В 2018 году на хлопкоочистительный завод поступило 1357,3 тонны хлопка-сырца 2-го сорта 2-го сорта, 273,5 тонны хлопка-сырца 3-го сорта 2-го сорта, 344,0 тонны хлопка-сырца 4-го сорта 2-го сорта. В результате запуска созданной установки уровень чистоты хлопкового сырья повысился и перешел на 1-й сорт.

Для расчета экономического эффекта в первую очередь необходимо собрать необходимые данные. Для этого сначала необходимо рассчитать капитальные затраты, необходимые для изготовления устройства. Затем мы рассчитываем итоговые показатели эффективности и, наконец, определяем экономическую эффективность.

Общая стоимость изготовления устройства составила 48085489 сумов. Затраты на электроэнергию возникают во время эксплуатации устройства. Определяем стоимость электроэнергии.

Для нового оборудования потребуется n электродвигателей (7,0 кВт и 3,0 кВт). В дни приема хлопка 2-го сорта оборудование работает в 2 смены по 8 часов в сутки.

Время работы = $n * 8 * m = 8$ нм часов

Затраты на электричество

Рассчитываем по формуле $E = T * N * S$.

Где: T - наработка оборудования, часы;

N - мощность двигателя в оборудовании, кВт;

S - размер платы за 1 кВт электроэнергии, сумах.

Процесс тестирования нового устройства в производственных условиях проводился на основе разработанной методики. Каждый сорт рассчитывался отдельно для хлопка-сырца.

1. Результаты экспериментальных испытаний И-35; Промышленный сорт III / 2 класса, массовая доля примесей в хлопке-сырце 11,9%, массовая доля влаги 13,5% проведена на опытном образце. Уровень загрязнения первичного хлопка-сырца составил 11,9%, а после очистки - 5,4%. Когда мы рассчитали результат, полученный по уравнению, эффективность очистки была следующей.

$$П = \frac{C_1 - C_2}{C_1} \cdot 100 = \frac{11,9 - 5,4}{11,9} \cdot 100 = 54,6\%$$

По результатам, общая эффективность очистки составила 54,6%.

Хлопок, допущенный ко второму сорту, по нормативным показателям соответствует требованиям первого сорта второго сорта после очистки перед прядением. Закупочная цена хлопка-сырца следующая.

2. Результаты экспериментальных испытаний И-35; Промышленный сорт IV / 2 класс - 15,5% от массы примесей в хлопке-сырце, массовая влажность 13,5%. По результатам общая эффективность очистки устройства составила 56,1%.

В нашем втором исследовании вышеупомянутый метод использовался для определения экономической эффективности. Мы определяем мировые закупочные цены на хлопок-сырец и прибыль, которую можно получить от этого сорта.

3. Результаты экспериментальных испытаний С-6524; Промышленный сорт II / 2-класс - 9,6% от массы примесей в хлопке-сырце, массовая влажность в опытном образце составила 10,5%. По результатам общая эффективность очистки устройства составила 53,1%. Мы получаем хлопок-сырец по закупочной цене и определяем прибыль от этого сорта.

Выводы

1. Изучены процесс очистки хлопка-сырца, производительность, процесс одновременной подачи разных видов хлопка-сырца (строительный, скоростной режимы).

2. Получены ожидаемые результаты теоретических, научных и практических исследований методов определения увеличения

эффективности очистки вновь смоделированного устройства в процессе очистки под действием механической силы на хлопок-сырец.

3. Теоретически изучены и изучены теория вероятности прилипания хлопка-сырца к пыльному барабану, взаимодействие сетки с хлопком-сырцом, прикрепленным к зубьям пилы во время чистки, режим работы, скорость вращения барабанов, диаметр, расстояние между сеткой и пилой, расстояние между сетками.

4. Классификация очистного устройства, основные технические требования к хлопкоочистительным машинам, расчет КПД ворсового барабана, методика расчета рабочего ролика очистного барабана.

5. Результаты экспериментальных испытаний И-35; Промышленный сорт III / 2 сорт, третий сорт, второй сорт хлопка проводился на опытном образце с массовой долей примесей в хлопке-сырце 11,9%, массовая влажность 13,5%. По результатам, общая эффективность очистки устройства составила 54,6%.

Использованные источники:

1. Мардонов Б., Р.Ф.Юнусов. Е.А.Лугачев Моделирование процесса ухода соринки из состава волокнистой массы при динамическом взаимодействии ее с сетчатой поверхностью. Сборник трудов «Инновационные технологии товаров народного потребления, качество и безопасность» Международная научно-практическая конференция Алматы, 17-18 июня, 2010. С.274-276.
2. Корабельников Р.В., Ибрагимов Х.И. Комплексный показатель воздействия очистителя хлопка на хлопок-сырец в процессе очистки // Изв.вузов. Технология текстильной промышленности. –2008, №4.С.
3. Р.Х.Мақсудов. А.Ж.Жураев, Эффективная конструкция очистительной секции хлопкоочистительного агрегата. Международная научно-техническая конференция. Текстильный институт ИВГПУ, 2013 г.
4. А.Ж.Джураев. и др. Разработка конструкций и методик расчета параметров колковых барабанов. LAP Lambert Academic publishing. 2016 г.

ОПРЕДЕЛЕНИЕ ПАДЕЖА И ПАДЕЖНЫХ ОКОНЧАНИЙ В КОРЕЙСКОМ ЯЗЫКЕ

Аннотация: Эта статья о падеже и падежных окончаниях в корейском языке. Так как во многих языках существует падежи и падежные окончания и корейский язык не исключение. В статье рассматриваются падежи и падежные окончания и они приведены в примерах.

Ключевые слова: падеж, частица, окончание, морфемы, вспомогательные частицы, падежные частицы.

*Abrorova N. F.
teacher*

Samarkand State Institute of Foreign Languages

DEFINITION OF CASE AND CASE ENDINGS IN KOREAN

Annotation: This article is about case and case endings in Korean. Since many languages have cases and endings and Korean is no exception. The article deals with cases and case endings and some of them are given in examples.

Key words: case, particle, ending, morphemes, auxiliary particles, falling particles.

Термин «*падеж*» в корейском языкознании 격 является калькой с китайского языка '格' [gyeok] и выражается посредством специальных частиц (окончаний). По функциональности падежи подразделяются на именительный – 주 ('主' [ju]), винительный – 목적 ('目的' [mokjeok]), дополнительный - 보 ('補' [bo]), атрибутивный – 관형 ('冠形' [gwanhyeong]), предикативный – 서술 ('敍述' [seooul]), звательный – 독립 ('獨立' [dokrib]), обстоятельственный – 부사 ('副詞' [busa]) падежи.

Исследование единства грамматического значения и грамматических форм падежных частиц корейского языка, вопросы классификации, а также методический и теоретический аспекты проблемы классификации падежных частиц в современном корейском языке составляют наибольшую трудность в изучении корейского языка в целом[1:59-68].

В некоторых случаях падеж как грамматическая единица имеет несколько форм. В корейском языке наименьшую грамматическую единицу, наделенную определенным значением и формой, называют «морфемой» 형태소 (в корейском языкознании калька с китайского «形態素» [hyeongtaeso]). Морфемы, в свою очередь подразделяются на самостоятельные (независимые) (в корейском языкознании 자립형태소 калька с китайского «自立形態素» [jaribhyeongtaeso]) и несамостоятельные (зависимые) морфемы (в корейском языкознании 의존형태소 калька с китайского «依存形態素» [uijonhyeongtaeso]), на лексические (в корейском языкознании 실질형태소 калька с китайского «實質形態素» [siljilhyeongtaeso]) и грамматические морфемы (в корейском языкознании 형식형태소 калька с китайского «形式形態素» [gyeongsikhyeongtaeso])[2:71-91].

1.1. Частицы корейского языка с точки зрения внутренней структуры слова

Морфема (형태소) - это самая малая грамматическая единица, имеющая определенное значение. Разные виды одной морфемы, возникшие из-за чередования звуков, называются алломорфом той или иной морфемы. Поэтому, в некоторых случаях, морфем, имеющих одинаковые значения, может быть две или три.

В корейском языке морфемы имеют не только одинаковое значение, но и дополнительное распределение между собой. Дополнительное распределение означает, что элементы не наслаиваются, они как бы «эксклюзивны», и при этом, дополняя друг друга, составляют одно целое. Поэтому падежные частицы «**이**» (именительный падеж) и «**을**» (винительный падеж) используются после согласных, а падежные частицы «**가**» (именительный падеж) и «**를**» (винительный падеж) - только после гласных[3:59-64].

Итак, падежные частицы, как минимальные грамматические единицы – морфемы, подразделяются на морфы (형태) и алломорфы (이형태). По функциональности подразделяются на самостоятельные (자립형태소) и зависимые морфемы (의존형태소), например:

철수가 밥을 아까 먹었다. Чольсу только что покушала.

В данном предложении к самостоятельным морфемам относятся: 철수, 밥, 아까; к зависимым относятся: “-가, -을, 먹-, -었, -다”.

По значению морфемы подразделяются на *реальные морфемы* (실질형태소) в предложении к ним относятся “철수, 밥, 아까, 먹”; и на *формальные морфемы* (형식형태소), к ним относятся: «-가, -을, -었, -다».

В случае когда у одной морфемы имеется несколько алломорфов (이형태), например, в именительном падеже с частицами «0|/가» основным алломорфом является «0|», а «가», не являющейся представительным морфом, называется алломорфом. Таким образом, в случае когда «0|» является морфом именительного падежа, «가», является его алломорфом, т.е., когда «0|» выступают морфемой, включается и его алломорф, появившийся из-за конечной гласной основы слова. Таким образом, в корейском языке падежные частицы имеют 27 морфем, которые подразделяются на 19 морфов и 8 алломорфов.

Вспомогательные частицы, как минимальные грамматические единицы – морфемы, также подразделяются на морфы (형태) и алломорфы (이형태). Изучив систему вспомогательных частиц корейского языка, мы приходим к следующему результату: вспомогательная частица «은» является морфом, «는» - его алломорфом; частицы «도, 만, 까지, 마저, 조차, 부터, 밖에, 마다, 처럼, 보다, 마냥, 다/다가, 커녕, 도록» являются морфами. Частицы «(이)야, (이)나, (이)든, (이)야말로, (이)라도» также являются морфами, с той лишь разницей, что к основе слова, оканчивающейся на согласную, присоединяется суффикс «0|». В данном случае имеет место правило слогосложения корейского языка, по которому к основе слова, оканчивающемуся на согласную в качестве соединительного суффикса присоединяется суффикс «0|». Таким образом, в корейском языке вспомогательные частицы имеют 20 морфем, которые подразделяются на 19 морфов и 1 алломорф[4:96-102].

Соединительные частицы корейского языка с точки зрения морфемики делятся на 5 морф и 1 алломорф: «과, 하고, 예(다), (이)며, (이)랑» являются морфами, «와» - алломорфом.

Падежные частицы 격조사 - это частицы, которые дают возможность предыдущим неизменяемым частям речи стать определённым членом предложения. В традиционной корейской грамматике падежные частицы подразделяются на семь видов. Это именительный, родительный, винительный, дополнительный, адвербиальный (который в свою очередь

делится на дательный, местный и творительный падежи), вокативный (или звательный) и предикативный падежи.

Падежные частицы корейского языка, их классификация и функционально-семантические особенности с точки зрения их употребления в категории вежливости и в функциональных стилях, которые имеют весьма сложную и присущую лишь корейскому языку систему пересекающихся и параллельных грамматических, лексических и синтаксических форм, на первый взгляд являются необъяснимыми и часто неподдающимися изучению. Глубокое и всестороннее исследование этих особенностей, которые сами по себе являются закономерностью в аспекте развития языка в целом, стало актуальным для современного корейского языкознания. Таким образом, лингвисты пришли к необходимости исследовать одну из таких особенностей корейского языка - грамматические особенности падежных частиц.

Некоторые падежи корейского языка образуют *составную падежную форму* (в корейском языкознании 상호결합 - калька с китайского '相互結合' [*sanghogyeolhab*]), в которой на одну падежную частицу наращивается другая падежная частица и в таком случае значение комбинированной падежной формы составляется из отдельных значений ее компонентов, которых может быть два и более. При этом состав составной падежной формы определяется не только значением, но и функциями ее компонентов. Агглютинативный характер корейского языка, в котором каждая частица несёт сразу несколько неразделимых значений, обуславливает их особенность - не образовывать неделимых структур и не изменяться под влиянием других частиц. Благодаря этому слово с составной формой может одновременно выражать несколько грамматических значений[5].

Подводя итоги исследования падежных окончаний корейского языка, нами сделаны общие выводы, к которым мы пришли в ходе изучения особенностей падежных частиц современного корейского языка, а также дана основная характеристика грамматического выражения особенностей падежных частиц в корейском языке.

Использованные источники:

1. Ким О.А. К вопросу о классификации именных частей речи в корейском и русском языках (на материале употребления падежных частиц) // Материалы Международной научной конференции «The 8 International Conference on Korean Studies Central Asian Association for Korean Studies» «Korean Studies and University Cooperation between Central Asian and Korea». Узбекистан. – Т.: ТашГИВ, 2008. – С. 59-68.
2. Ким О.А. К вопросу о классификации именных частей речи в корейском языке (на материале употребления именительного и винительного падежей) // «Korean studies» Vol. 10. Международный научный журнал Центральноазиатской ассоциации корееведения. – Сеул, 2008. – С. 71-91.

3. Ким О.А. Классификация падежных частиц в корейском языке // Шарқшунослар анжумани. – Т.: ТошДШИ, 2009, –2-сон. – С. 59-64.
4. Ким О.А. Грамматические особенности частиц винительного падежа 'eul/reul' в корейском языке // Шарқшунослар анжумани. –Т.: ТошДШИ, 2009. –3-сон. – С. 96-102
5. Ким Джонг Сук, Пак Донг Хо, И Бёнг Гю и др. Грамматика корейского языка для иностранцев – 1. Комуникейшн букс, - Сеул. 2005.

УДК:619.616-035.1

*Авезимбетов Ш.Д., кандидат ветеринарных наук
доцент
Нукусский филиал Самаркандского института
ветеринарной медицины*

МЕТОДЫ ЛЕЧЕНИЯ И ЛАБОРАТОРНОЕ ИССЛЕДОВАНИЕ СЕКРЕТНОГО ХРОНИЧЕСКОГО ЭНДОМЕТРИТА

Аннотация: Латентный хронический эндометрит в Республике Каракалпакстан, морфологические изменения при заболевании, причины заболевания, отличие воспалительного процесса слизистой оболочки матки при хроническом скрытом эндометрите и катаральном эндометрите, препараты для лечения заболевания, диагностика, лабораторные исследования. Показана методика считывания реакции, оптимальное хранение животных.

Ключевые слова: Endometritis latensronica, морфологический, возбудитель, оплодотворение, цикл, киста, биопсия, токсический, течка, экссудат.

*Avezimbetov Sh.D., Candidate of Veterinary Sciences
Associate Professor
Nukus branch of the Samarkand Institute
veterinary medicine*

METHODS OF TREATMENT AND LABORATORY EXAMINATION OF SECRET CHRONIC ENDOMETRITIS

Abstract: Latent chronic endometritis in the Republic of Karakalpakstan, morphological changes in the disease, causes of the disease, the difference between the inflammatory process of the uterine mucosa in chronic latent endometritis and catarrhal endometritis, drugs for the treatment of the disease, diagnostics, laboratory tests. The method of reading the reaction, optimal storage of animals is shown.)

Keywords: Endometritis latensronica, morphological, causative agent, fertilization, cycle, cyst, biopsy, toxic, estrus, exudate.

Введение; В Республике Каракалпакстан бесплодие коров широко распространено из-за факторов окружающей среды. Основная причина этого - латентный хронический эндометрит (Endometritis latensronica).

При обследовании животноводческой фермы «Лочин» Турткульского района Республики Каракалпакстан у 4 из 100 дойных коров выявлен латентный хронический эндометрит. характеризуется отсутствием

хороших проявлений изменений (при клиническом осмотре). Начало заболевания вызвано использованием спермы, загрязненной условно-патогенной или патогенной микрофлорой, что приводит к инфицированию в результате повторного неправильного оплодотворения.

Основная часть: При диагностике заболевания было учтено, что животное не оплодотворялось даже после повторного осеменения. Обычно ритм полового цикла не нарушается. Во время полового акта наблюдается большое количество выделений из влагалища и смесь слизистой жидкости. Часто патологический процесс распространяется на мышечный слой. Слизистые оболочки атрофируются, складки расправляются, а в некоторых местах наблюдается грибковое или бородачье разрастание соединительной ткани. Вместо маточных желез появляются кисты разных размеров.

Для подтверждения диагноза проведена биопсия слизистой оболочки матки и гистологическое исследование. При скрытом эндометрите наблюдались дистрофия и уплотнение слизистой оболочки матки, скопление лимфоидных клеток, разрыв маточных желез, сильное набухание стромы и образование тромбов.

Токсичные вещества, которые накапливаются в матке при скрытом эндометрите, губительно действуют на сперму. Поэтому для восстановления фертильности животного необходимо очистить матку от экссудата и повысить ее тонус. Было доказано, что использование тканевой терапии и массажа является эффективным. Иногда рекомендую промыть матку за 1-2 часа до оплодотворения физиологическим или содово-солевым раствором или непосредственно перед оплодотворением. При хроническом скрытом эндометрите воспалительный процесс слизистой оболочки матки возникает изначально, как при катаральном эндометрите. Впоследствии скорость воспаления эндометрия уменьшается, и поступление экссудата в матку постепенно прекращается. В связи с этим также прекращается отток экссудата из матки. Однако изменения эндометрия, образовавшиеся в начале воспаления, продолжают продолжаться. В клинических исследованиях они не обнаружены. В результате упал явный признак эндометрита (патологическое отделение от матки), и процесс стал латентным. Поскольку сопротивление тела и эндометрия снижается с последующим наступлением течки, овуляции и овуляции, воспалительный процесс в эндометрии усиливается, и экссудат снова попадает в полость матки, а затем выходит наружу.

Для лечения заболевания использовались следующие препараты.

- 1) вместо оплодотворения во время фазы возбуждения полового цикла в матку вводили 20-30 мл мастисана А в виде 5% жирного раствора;
- 2) Через 12-16 часов после оплодотворения в матку однократно вводили неовитин (0,5 г), полимиксин - М (0,5-1 г), хлорамфеникол натрия

сукцинат (0,5-1 г). Перед доставкой в матку антибиотики растворяли в 10 мл 1% раствора натрия хлорида или 0,25-0,5% раствора новокаина.

Диагностика. По клиническим признакам сложно поставить надежный диагноз. Хронический скрытый эндометрит диагностируют при обнаружении патологических выделений из матки во время охоты. Они не такие прозрачные, как обычно, но частицы гноя смешанные и очень мутные. Через 1–3 дня после охоты патологическое отделение от матки прекращается и не наблюдается снова, пока не начнется следующая течка и не начнется охота. Хронический оккультный эндометрит можно более точно диагностировать с помощью одного из следующих лабораторных методов.

Ветеринар может организовать лабораторное исследование слизистой оболочки шейки матки на ферме, в центре искусственного осеменения или в ветеринарной лаборатории для диагностики и определения характера воспалительного процесса у бесплодных животных. Для удаления лохий или мокроты сначала очищаются наружные гениталии, затем во влагалище вводится рука в пластиковой перчатке, внутренняя часть подводится к шейке матки и помещается в контейнер или пробирку и записывается номер или кличка коровы. Осмотр материала проводится немедленно, но при хранении в прохладном месте - через 2–3 часа. При необходимости проводится микроскопия слизистой оболочки шейки матки-влагалища, биопсия эндометрия для определения причины бесплодия.

Способ 2. Добавьте в лабораторный раствор 2 мл лохии и 2 мл 1% раствора уксусной кислоты или 0,1% раствора этакридина лактата. Если лохии удаляются у коровы при нормальном прохождении послеродового периода, то в растворе образуется сгусток муцина, который при встряхивании не разрушается; осаждающая жидкость остается прозрачной. В случае эндометрита образуется осадок, жидкость становится мутной при легком встряхивании пробирки.

Ароматический ряд в мокроте течи при воспалительном процессе основан на обнаружении токсических веществ (индол, скатол и др.). Возьмите 2 мл лохии или слизи в растворе и добавьте 2 мл 20% раствора трихлоруксусной кислоты. Смесь фильтруют через бумажный фильтр и 0,5 мл азотной кислоты добавляют к 2 мл фильтрата, не содержащего белков. Содержимое варят одну минуту. После охлаждения к смеси добавляют 1,5 мл 33% раствора гидроксида натрия.

Если реакция положительная, раствор становится желтым. Желто-зеленый цвет указывает на умеренное катаральное воспаление эндометрия, оранжевый - гнойно-катаральное воспаление слизистой оболочки матки.

Заключение: хронический катарально-гнойный эндометрит - это острое или хроническое катаральное воспаление матки, вызванное попаданием в матку микроорганизмов, вызывающих гнойное воспаление.

Наблюдались отек слизистой оболочки матки, выраженная гиперемия и кровоизлияние, а также появление размягченных плоскостей разного размера, гнойная инфильтрация, дегенерация, некроз и обострение тканей.

Катарально-гнойное воспаление матки сопровождалось ухудшением общего состояния животного, снижением аппетита и похуданием. Иногда бывает жар. Половой цикл не соблюдается или нормальный (анафродизия и нимфомания). Периодически из половых органов вытекает белый кремообразный катарально-гнойный экссудат.

Остановить патологический процесс сложно. Однако из-за глубоких изменений слизистой оболочки матки после заболевания аборт может наблюдаться даже при беременности животного.

Хронический скрытый эндометрит диагностируется во время течки только по наличию гнойных прожилков и других примесей в мокроте течки и приводит к многократному неоплодотворению коров (микробные токсины и другие продукты воспаления отрицательно влияют на эмбрион).

Повышение пищевой ценности кормов при проведении профилактических мероприятий, введение различных минеральных добавок в зависимости от физиологических потребностей обеспечивает животных селеном, витаминами А, Е, снижает долю концентрата в кормах.

Особое внимание следует уделять созданию оптимальных санитарно-гигиенических условий содержания животных: соблюдение параметров микроклимата помещений для содержания скота, регулярная дезинфекция родильных домов, оказание высококвалифицированной акушерской помощи и кормление животных активной (мацион) езда необходима.

Кроме того, программы профилактики эндометрита должны включать регулярный мониторинг инфекционных заболеваний, их своевременное выявление и вакцинацию.

Использованные источники:

1. Ata-Kurbanov Sh.B. Eshburiev V.M. Veterinariya akusherligi fanidan amaliy-laborator mashg'ulotlar. Samarqand, 2009.
2. Ata-Kurbanov Sh.B., Eshburiev V.M. Hayvonlar ko'payish biotexnikasi. Samarqand. "N.Doba" XT, 2012.
3. Баймишев Х.Б., Землянкин В.В., Баймишев М.Х. Практикум по ветакушерству и гинекологии. Самара 2012.
4. Eshburiev V.M. Veterinariya akusherligi. Samarqand – 2018.

*Айвазян А.Л.
студент магистратуры
Костромской государственной университет (КГУ)
Россия, Кострома*

УПРАВЛЕНИЕ НАЛОГОВЫМИ РИСКАМИ НА ПРЕДПРИЯТИЯХ ПИЩЕВОЙ ПРОМЫШЛЕННОСТИ

Аннотация: Всем предприятиям, независимо от специфики их деятельности необходимо помнить о рисках, которые могут грозить их бизнесу. Управляя налоговыми рисками, необходимо использовать законные схемы их минимизации. В данной статье рассмотрен ряд способов минимизации налогов как части процесса управления рисками.

Ключевые слова: налоговые риски, управление рисками, минимизация налогов.

*Aivazyan A.L.
graduate student
KGU
Russia, Kostroma*

TAX RISK MANAGEMENT IN THE FOOD INDUSTRY

All enterprises, regardless of the specifics of their activities, need to be aware of the risks that may threaten their business. When managing tax risks, it is necessary to use legal schemes to minimize them. This article discusses a number of ways to minimize taxes as part of the risk management process.

Key words: tax risks, risk management, tax minimization.

Причины возникновения налоговых рисков могут быть самыми разнообразными, к ним, например, относятся: изменение законодательства, разночтения в арбитражной практике, недостоверность информации о контрагентах, неверные решения руководства фирмы. Процесс управления налоговыми рисками включает в себя три этапа.

Во-первых, необходимо проанализировать и оценить возможные опасности. На этом этапе обсуждаются условия по новым договорам с контрагентами, схемы минимизации налогов, анализируется арбитражная практика по спорному вопросу.

Во-вторых, необходимо провести мероприятия, которые будут способствовать снижению налогового риска до приемлемого уровня, а в частности разработать необходимую первичную документацию, провести

консультирование персонала и в случае необходимости застраховаться от рисков.

В-третьих, необходимо определить допустимый уровень риска. При этом анализ факторов, оказывающим основное влияние на налоговый необходимо выявлять по следующему алгоритму:

1. Анализ внутренней документации фирмы.
2. Анкетирование сотрудников.
3. Анализ ситуации с участием ведущих специалистов и специалистов среднего звена предприятия.
4. Построение дерева событий.
5. Использование методики «событие - последствия».

Управление налоговыми рисками осуществляется при помощи налоговой политики предприятия, функции менеджеров предприятия, специальных мероприятий (опросов, инвентаризаций), внутреннего и внешнего аудита, автоматизации.

Рассмотрим на практических примерах, какие существуют легальные схемы минимизации налогов как части процесса управления рисками на предприятиях пищевой промышленности.

Первый способ. Необходимо проанализировать перечень прямых и косвенных расходов из декларации по налогу на прибыль, изучить возможность исключения некоторых статей прямых затрат и включения этих затрат в косвенные. На предприятиях пищевой промышленности это приводит к уменьшению налоговой прибыли, а бухгалтерская прибыль при этом остается прежней. На подготовительном этапе необходимо изучить стоимость данного вопроса, решить, стоит ли подавать уточненные декларации, ввязываться в арбитражный процесс и т.п. Далее необходимо подготовить налоговые регистры, которые нужно приложить к уточненной налоговой декларации. На третьем этапе, собственник бизнеса сможет вернуть деньги из бюджета, или засчитать денежные средства в счет будущих платежей, посредством подачи заявления в налоговую инспекцию.

Второй способ. На предприятиях пищевой промышленности выпускается продукция, облагаемая и не облагаемая налогом на добавленную стоимость (далее – НДС). В данном случае бухгалтер должен досконально изучить вопрос деления входящего налога на добавленную стоимость в дебет счета 68 «Расчеты по налогам и сборам» и счета 20 «Основное производство», однако, необходимо помнить, что возможно придется обосновывать налоговым органам увеличение оборотов по дебету счета 68 «Расчеты по налогам и сборам». Анализ п. 4 ст. 170 НК РФ, который гласит, что «суммы налога, предъявленные продавцами товаров (работ, услуг), имущественных прав налогоплательщикам, осуществляющим как облагаемые налогом, так и освобожденные от налогообложения операции, принимаются к вычету либо учитываются в их стоимости в той пропорции, в которой они используются для производства и (или) реализации товаров

(работ, услуг), имущественных прав, операции по реализации которых подлежат налогообложению (освобождаются от налогообложения), - по товарам (работам, услугам), в том числе основным средствам и нематериальным активам, имущественным правам, используемым для осуществления как облагаемых налогом, так и не подлежащих налогообложению (освобожденных от налогообложения) операций, в порядке, установленном принятой налогоплательщиком учетной политикой для целей налогообложения» позволяет сделать вывод о том, что налоговое законодательство позволяет компаниям делить «входящий НДС» как по мере реализации, так и по итогам налогового периода, но данный метод необходимо отразить в учетной политике для целей налогообложения.

Третий способ. Анализ дебета счета 91 «Прочие доходы и расходы», который не уменьшает налоговую базу по налогу на прибыль, возможно позволит выявить, что какие-то расходы можно учесть. Во-первых, внутренний или внешний аудит позволит выяснить цену вопроса, и если она окажется существенной, то следующим шагом должна стать подготовка необходимой первичной документации, а также уточненной налоговой декларации. Заключительным этапом данного способа будет возврат средств из бюджета или зачет их в счет будущих платежей.

Таким образом, управление налоговыми рисками позволит не потерять денежные средства компании. И минимизация налогов - часть этого процесса. При необходимости бухгалтерии предприятия необходимо будет подать уточненную декларацию, которая позволит компании вернуть часть средств, однако, перед любым действием, направленном на минимизацию налоговых рисков, необходимо просчитать возможную выгоду.

Четвертый способ. Использование льготных режимов налогообложения, путем дробления предприятия. Данный вид оптимизации может применяться исключительно при наличии четкой деловой цели. Налоговые органы в п. 1 письма от 11.08.2017 N СА-4-7/15895@ указывает, что исчерпывающий или строго императивный перечень признаков, свидетельствующий об обоснованности выводов налогового органа о формальности разделения (дробления) бизнеса, отсутствует. Следовательно, каждая ситуация налоговой службой, будет анализироваться индивидуально. Однако, существует примерный перечень признаков дробления, а в частности: участники схемы на применяют специальные режимы; участники схемы извлекли выгоду из дробления (т.е. уменьшили налоги или сохранили налоги на том же уровне, расширив бизнес); участники схемы ведут аналогичную экономическую деятельность; участники схемы возникли как субъекты экономической деятельности в течение небольшого промежутка времени перед началом применения схемы (т.е. регистрация индивидуального предпринимательства, создание компаний); участники схемы прямо или косвенно зависят друг от друга;

персонал, производственные мощности, складские помещения, товары распределены между участниками схемы лишь формально, на самом деле всеми руководит бенефициар схемы; участники схемы используют одни и те же вывески, обозначение, контакты, сайты, находятся по одному и тому же адресу, используют один и тот же IP-адрес, обслуживаются в одном и том же банке.

Избегая всех вышеназванных признаков, предприятие пищевой промышленности может построить схему по дроблению, которая будет работать в правовом поле.

Пятый способ. Создание резервов в налоговом учете, для которых характерен общий порядок действий:

1) решение о создании резерва должно быть отражено в учетной политике;

2) сумма отчислений в резерв должна быть экономически обоснована;

3) списание расходов за счет резерва.

Создавать резервы по налогу на прибыль могут только организации, которые используют метод начисления. Организации, использующие кассовый метод, создавать резервы не могут. Создание резерва - право организации, а не обязанность. Организация самостоятельно решает, создавать ли ей резервы и какие именно.

В налоговом учете к основным видам оптимизации можно отнести следующие виды резервов: резерв по сомнительной дебиторской задолженности, резерв на оплату отпусков, резерв на ремонт основных средств.

Использованные источники:

1. Налоговый кодекс Российской Федерации (часть вторая) от 05.08.2000 № 117-ФЗ (ред. от 23.11.2020) // Официальный интернет-портал правовой информации. – URL: <http://pravo.gov.ru> (дата обращения 10.12.2020)

2. Письмо ФНС России от 11.08.2017 № СА-4-7/15895@ «О направлении обзора судебной практики, связанной с обжалованием налогоплательщиками ненормативных актов налоговых органов, вынесенных по результатам мероприятий налогового контроля, в ходе которых установлены факты получения необоснованной налоговой выгоды путем формального разделения (дробления) бизнеса и искусственного распределения выручки от осуществляемой деятельности на подконтрольных взаимозависимых лиц» // Официальный интернет-портал правовой информации. – URL: <http://pravo.gov.ru> (дата обращения 10.12.2020)

*Аймуханова С.А.
студент магистратуры ОГУ
РФ, г. Оренбург
научный руководитель: Гребнев Г.Д., канд. экон. наук
доцент
ОГУ
РФ, г. Оренбург*

МЕТОДИКИ АНАЛИЗА ДЕБИТОРСКО-КРЕДИТОРСКОЙ ЗАДОЛЖЕННОСТИ

Аннотация: В статье рассмотрена сущность основных методик экономического анализа дебиторской и кредиторской задолженностей.

Ключевые слова: дебиторская задолженность, кредиторская задолженность, экономический анализ.

*Aimukhanova S.A.
master 1 st year student
of OSU
Russian Federation, Orenburg
Scientific adviser: Grebnev G.D., Candidate of Economic Sciences
Associate Professor
of OSU
Russian Federation, Orenburg*

METHODS OF ANALYSIS OF ACCOUNTS RECEIVABLE AND PAYABLE

Abstract: The article examines the essence of the main methods of economic analysis of receivables and payables.

Key words: accounts receivable, accounts payable, economic analysis.

В современных экономических условиях деятельность каждого хозяйствующего субъекта связана с определенной долей риска. В связи с этим возникает необходимость осуществления объективной оценки финансового состояния, надлежащего уровня надежности и платежеспособности своих контрагентов.

Также контролируются условия образования и состояние дебиторско-кредиторской задолженности организации, осуществляется ранжирование клиентов, прогнозируются поступления денежных средств от дебиторов и осуществляется поиск снижения числа сомнительных и безнадежных долгов.

Наиболее эффективно управлять имеющимися у предприятия обязательствами помогает применение различных методик экономического анализа дебиторско-кредиторской задолженности.

В настоящее время дебиторская и кредиторская задолженность весьма существенно влияют на финансовое положение, использование денежных средств в обороте и величину прибыли.

Актуальность выбранной темы связана со значительным ростом уровней дебиторской и кредиторской задолженностей в Российской Федерации, а также в регионах и у отдельных предприятий, а также отсутствием универсальной и комплексной методики оценки данных показателей.

Несмотря на успешное развитие методов экономического анализа возникает необходимость дальнейшего совершенствования методов анализа дебиторской и кредиторской задолженности так как анализ состояния расчетов организаций с дебиторами и кредиторами имеет существенное значение для оценки деловой активности организации, оборачиваемости капитала, ликвидности организации и финансовой устойчивости.

Между дебиторской и кредиторской задолженностью есть много общего, но, существуют и определенные различия, что отражается на методике их анализа [1].

Существует большое число авторских методик проведения сравнительного анализа дебиторской и кредиторской задолженностей, в число которых входят горизонтальный, вертикальный, коэффициентный, балансовый методы.

Применение вертикального метода в экономическом анализе дебиторской и кредиторской задолженностей позволяет оценить качество долговых обязательств. Обозначим дебиторскую задолженность как ДЗ, а кредиторскую как КЗ. Вертикальный метод оценки позволяет определить удельный вес просроченной задолженности в долговых обязательствах, рассчитывая при этом коэффициенты соотношения дебиторской и кредиторской задолженностей, учтенные как в условиях договора, так и в числе просроченной по ниже представленным значениям:

$$K_{\text{соот.}} > 1 (ДЗ > КЗ)$$

$$K_{\text{соот.}} = 1 (ДЗ = КЗ)$$

$$K_{\text{соот.}} < 1 (ДЗ < КЗ)$$

Рассмотрим методику коэффициентной оценки движения дебиторской и кредиторской задолженностей. Поиск необходимых коэффициентов осуществляется следующим образом:

$$K_1 = x = \frac{\text{Возникшая ДЗ (КЗ)}}{\text{Остаток ДЗ(КЗ) на конец периода}} * 100\%$$

$$K2 = x = \frac{\text{Величина непогашенной в срок ДЗ(КЗ)}}{\text{Величина ДЗ(КЗ) на начало периода} + \text{возникшая ДЗ(КЗ)}}$$

Первый коэффициент называется коэффициентом возникновения задолженности, который показывает удельную величину возникшей задолженности по отношению к ее остатку на конец периода. Если его величина будет меньше 100%, то можно сделать вывод о том, что осуществление контроля за движением дебиторской задолженности на предприятии осуществляется не надлежащим образом.

Второй коэффициент показывает процент погашения дебиторской и кредиторской задолженностей предприятия за отчетный период [7].

Применение методики коэффициентного анализа позволяет определить долю дебиторской задолженности в оборотных активах, провести анализ ее структуры, качественного состояния и оценить динамику сомнительной задолженности. Аналогично анализируется кредиторская задолженность на предприятии. Затем сопоставляются полученные результаты.

Применение методики горизонтального анализа заключается в сопоставлении показателей соответствующих статей отчетности за различные периоды времени. Горизонтальный анализ позволяет выявить значительные изменения в деятельности организации и в том числе возможные отклонения в ее финансовом состоянии [6].

Такие авторы как Надольская Н.А. [3] и Чеглакова С.Г. [4] предлагают также применение методики балансового метода анализа дебиторско-кредиторской задолженности. Его суть заключается в определении активного сальдо, то есть величина дебиторской задолженности превышает величину кредиторской задолженности, и пассивного сальдо, то есть величина кредиторской задолженности превышает величину дебиторской. Активное и пассивное сальдо отражают факт неравновесия задолженностей и в целом влияют на финансовое положение предприятия негативно.

Исследование методов анализа дебиторской и кредиторской задолженностей в отечественной экономической системе показало, что в любой авторской методике, анализ завершается их оборачиваемостью. Расчет показателей оборачиваемости производится в виде коэффициентов или по числу дней одного оборота.

Коэффициент оборачиваемости дебиторской задолженности показывает количество уведомлений о погашении покупателями своей задолженности перед предприятием за отчетный период.

$$Kоб (ДЗ) = x = \frac{\text{Выручка}}{\text{Среднегодовая ДЗ}} [2]$$

Коэффициент оборачиваемости кредиторской задолженности показывает скорость погашения предприятием своей задолженности перед

кредиторами, то есть количество уведомлений о погашении имеющееся задолженности у организации за отчетный период.

$$\text{Коб (КЗ)} = x = \frac{\text{Выручка}}{\text{Среднегодовая КЗ}} \quad [2]$$

Также проводится сравнительный анализ дебиторской и кредиторской задолженностей.

В случае превышения доли кредиторской задолженности над дебиторской, делается вывод о нерациональном использовании имеющихся у организации средств, а также недостаточной состоятельности предприятия.

Превышение дебиторской над кредиторской задолженностью также означает отвлечение средств из оборотных средств компании, что в дальнейшем может стать причиной привлечения заемных средств для обеспечения текущей деятельности предприятия [5].

С целью дальнейшего улучшения финансового состояния предприятию необходимо следить за соотношением дебиторской и кредиторской задолженностей и своевременно контролировать состояние расчетов по просроченным задолженностям.

Для улучшения финансового состояния предприятия необходимо следить за соотношением дебиторской и кредиторской задолженностей, контролировать состояние расчетов по просроченным задолженностям.

При использовании показателей оборачиваемости, возможно определить длительность операционного и финансового циклов.

Операционный цикл отражает промежуток времени, в течение которого финансовые ресурсы мобилизованы в дебиторской задолженности.

Финансовый цикл характеризует разрыв между сроком платежа по своим обязательствам перед поставщиками и получением денег от покупателей, то есть показывает время, в течение которого денежные средства отвлечены из оборота.

Таким образом, финансовое состояние каждого предприятия зависит от наличия и эффективности использования финансовых ресурсов, обеспеченности собственными оборотными средствами, величины оборачиваемости и платежеспособности. Также проведение экономического анализа дебиторской и кредиторской задолженностей помогает выявить отвлеченные из оборота денежные средства.

В настоящее время дебиторская и кредиторская задолженности являются неотъемлемой частью денежных отношений и в значительной степени влияют на деятельность каждого предприятия. Величина дебиторской и кредиторской задолженностей во многом влияет на формирование итоговых показателей финансово-хозяйственной деятельности организации, что во многом объясняет необходимость наиболее эффективного управления и проведение качественного анализа

дебиторской и кредиторской задолженностей. Все это позволяет своевременно контролировать состояние расчетов с дебиторами и кредиторами, определить потребность в дополнительных ресурсах для покрытия задолженности, а также снизить риск невозврата дебиторской задолженности и образования просроченной задолженности.

Использованные источники:

1. Бороненкова, С.А. Анализ бухгалтерской (финансовой) отчетности [Текст]: учеб. пособие / С.А. Бороненкова, М. В. Мельник, А.В. Чепулянис ; М-во образования и науки Рос. Федерации, Урал. гос. экон. ун-т. - Екатеринбург [Изд-во Урал. гос. экон. ун-та], 2017. - 296 с.
2. Маслова Л.И., Ларионова О.В., Перминова И.М. Экономический анализ учебное пособие и практикум. Стандарт третьего поколения / Л.И. Маслова, О.В. Ларионова, И.М. Перминова. Под общ. ред. Л.И. Масловой. Екатеринбург: Издательство Дом «Ажур», 2018. 258 с.
3. Надольская Н.А. Экономический анализ хозяйственной деятельности предприятия [Текст] учеб. пособие / Н.А. Надольская; М-во образования и науки РФ, Урал. гос. экон. ун-т. - Екатеринбург: [Изд-во Урал гос. экон. ун-та], 2017. - 72 с.
4. Чеглакова С.Г. Анализ финансовой отчетности: учебное пособие / С.Г. Чеглакова. - 3-е изд., перераб. и доп. - М., Дело и Сервис, 2017. - 304 с.
5. Когденко В. Г. Экономический анализ: учебное пособие. 2-е изд., перераб. и доп. М.: ЮНИТИ-ДАНА, 2016.
6. Савицкая Г. В. Комплексный анализ хозяйственной деятельности предприятия. М.: Инфра-М, 2016.
7. Елютина Ю. П. Методика экономического анализа дебиторской и кредиторской задолженности предприятий

Акрамова Ш.Г
научный сотрудник
Научно-исследовательский
центр при Ташкентском государственном
экономическом университете
Узбекистан, г. Ташкент

ПОЛОЖЕНИЕ ЖЕНЩИН НА РЫНКЕ ТРУДА В РЕСПУБЛИКЕ УЗБЕКИСТАН В СВЕТЕ ГЛОБАЛЬНЫХ ТЕНДЕНЦИЙ

Аннотация: В статье анализируются глобальные тенденции степени участия женщин на рынке труда. Определены основные факторы влияющие на уровень экономической активности женщин. Изучены особенности участия женщин на рынке труда Республики Узбекистан и разработаны предложения по созданию условий для их самореализации.

Ключевые слова: рынок труда, женщины, экономическая активность, занятость, безработица, разрыв в заработной плате, экономическое развитие

Akramova Sh. G.
senior researcher
Research Center under
Tashkent State University of Economics
Uzbekistan, Tashkent

THE POSITION OF WOMEN IN THE LABOR MARKET IN THE REPUBLIC OF UZBEKISTAN IN THE LIGHT OF GLOBAL TRENDS

Abstract: The article analyzes global trends of women's participation rate in the labor market. The main factors influencing the level of women's economic activity have been determined. The peculiarities of women's participation in the labor market of the Republic of Uzbekistan were studied and proposals were developed to create conditions for the self-realization of women.

Key words: labor market, women, economic activity, employment, unemployment, wage gap, economic development

Анализ статистических данных показывает, что уровень экономической активности женщин в среднем по миру и в отдельных регионах постепенно снижается на протяжении последних 20 лет. В целом, несмотря на различия в разных странах, за последние 25 лет произошло явное снижение уровня экономической активности как среди женщин, так и среди мужчин во всем мире. В частности, с 1990 по 2019 год уровень

экономической активности женщин снизился с 50,9% до 47,7%, а у мужчин - с 80,2% до 74,7%. В 2020 году уровень экономической активности женщин в мире составил 46,9%, а в Узбекистане - 52,3%. В отличие от средней мировой тенденции, в Узбекистане ситуация иная. Отмечается, что уровень экономической активности женщин имеет тенденцию к повышению в течение 2000-2020 годов. Средний мировой уровень экономической активности женщин в этот период изменился с 50,9% до 46,9%, а в Узбекистане - с 50,8% до 52,3% соответственно.



Рисунок 1. Количество занятых и уровень занятости в Узбекистане в 2010-2019 гг.⁴⁸

Анализ показателей занятости в стране показал, что количество занятых женщин стабильно увеличивалось в течение 2010-2017 годов и резко сократилось в 2018-2019 годах. Понятно, что распределение рабочей силы по отраслям определяется прежде всего структурой национальной экономики. В Узбекистане уровень занятости женщин в ключевых секторах экономики, т.е. в сельском хозяйстве, промышленности и сфере услуг, близок к среднемировому. Самый высокий уровень занятости женщин в промышленном секторе наблюдается в Китае (25,1 %) и Иране (24,3 %). По данным Всемирного банка, около 15,5% женщин в Узбекистане заняты в промышленности. Доля женщин, занятых в сельском хозяйстве в республике, также полностью соответствует среднемировым показателям.

⁴⁸Составлено автором на основании данных официального сайта Госкомстата Республики Узбекистан по гендерной статистике Узбекистана.. [Электронный ресурс] <https://gender.stat.uz/uz/osnovnye-pokazateli-uz/trud-uz/aktivnoe-naselenie-uz/1032-iqtisodiy-faol-aholi-soni> (дата обращения 05.06.2020)

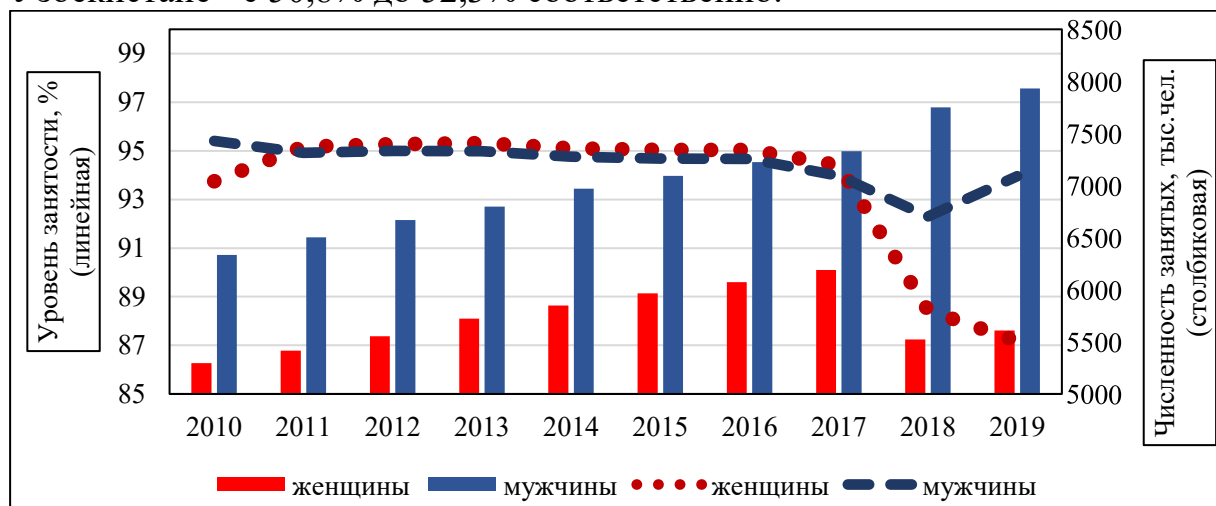

Рисунок 2. Уровень занятости женщин в сельском хозяйстве в Узбекистане и в среднем по миру (к общему количеству занятых женщин, %) ⁴⁹

Современный этап социально-экономического развития характеризуется проникновением информационных технологий во все сферы жизни и их быстрым развитием, что приводит к развитию сектора услуг в связи с нематериальной экономикой. Соответственно, уровень занятости в сфере услуг растет. Например, в Малайзии уровень занятости женщин в сфере услуг вырос с 53,3% до 75% за последние 20 лет, а в России - с 63,1% до 80,7%. По состоянию на 2020 год 95% женщин в ОАЭ и 90% в США и Канаде заняты в сфере услуг. По данным Всемирного банка, 58,7% женщин Узбекистана заняты в сфере услуг. Исходя из этих данных, видно, что еще есть большие возможности для развития сферы услуг в стране. В таблице ниже показано распределение количества рабочих мест по видам экономической деятельности в Узбекистане (Таблица 1). По данным за три года доля женщин, занятых в различных сферах экономической деятельности, существенно не изменилась.

⁴⁹ Составлено автором на основании данных официального сайта Всемирного банка. [Электронный ресурс] <https://databank.worldbank.org/reports.aspx?source=2&series=SL.TLF.CACT.FM.NE.ZS#> (дата обращения 18.05.2020)

Таблица 1.

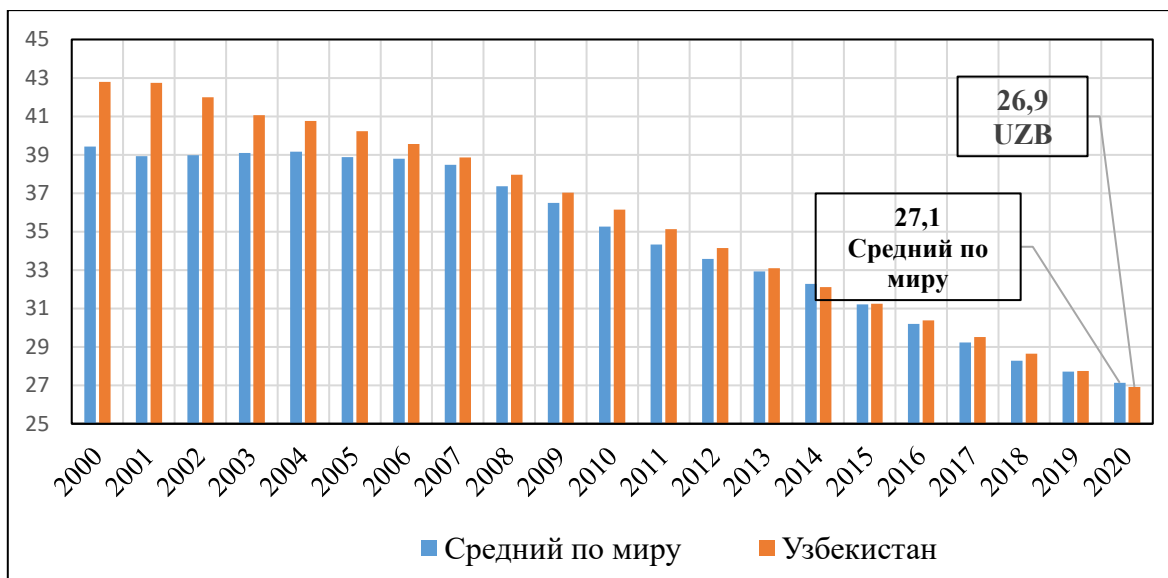
Распределение численности занятых по видам экономической деятельности по полу в среднем за 2019 год (в среднем за год)⁵⁰

	В % к итогу				Распределение по полу, %			
	Женщины		Мужчины		Женщины		Мужчины	
	2016	2019	2016	2019	2016	2019	2016	2019
Всего	100,0	100,0	100,0	100,0	45,7	41,6	54,3	58,4
Сельское, лесное и рыбное хозяйство	26,3	27,3	28,4	25,4	43,7	43,2	56,3	56,8
Промышленность	12,7	14,3	14,3	12,9	42,9	44,0	57,1	56,0
Строительство	1,2	1,5	16,5	15,7	5,8	6,2	94,2	93,8
Торговля	12,3	13,2	9,7	8,8	51,5	51,5	48,5	48,5
Перевозка и хранение	0,8	0,8	8,2	7,6	7,2	7,2	92,8	92,8
Услуги по проживанию и питанию	2,7	2,9	2,0	1,9	52,4	52,1	47,6	47,9
Информация и связь	0,3	0,4	0,6	0,5	32,7	32,3	67,3	67,7
Финансовая и страховая деятельность	0,4	0,5	0,6	0,6	37,3	34,8	62,7	65,2
Образование	13,8	15,3	3,7	3,5	75,6	75,7	24,4	24,3
Здравоохранение и предоставление социальных услуг	7,6	8,4	2,0	1,8	76,5	76,8	23,5	23,2
Искусство, развлечение и отдых	0,5	0,5	0,5	0,5	45,3	45,3	54,7	54,7
Прочие виды деятельности	21,4	14,9	13,5	20,8	57,1	33,4	42,9	66,6

Примечательно, что доля женщин, занятых в относительно высокооплачиваемом секторе - финансах и страховании - значительно снизилась по сравнению с другими видами деятельности.

⁵⁰ Составлено автором на основании данных официального сайта Госкомстата Республики Узбекистан по гендерной статистике Узбекистана [Электронный ресурс]. <https://gender.stat.uz/uz/osnovnye-pokazateli-uz/trud-uz/zanyatost-naseleniya-uz/1374-iqtisodiy-faoliyat-turlari-bo-yisha-bandlar-sonining-taqsimlanishi> (дата обращения 05.06.2020)



Рисунок 3. Количество безработных и уровень безработицы в Узбекистане в 2010-2019 гг.⁵¹

За анализируемые 2010-2019 годы уровень безработицы в стране также значительно вырос. Основная причина столь большой разницы в статистических показателях по годам является изменение методологии расчета безработицы. С 2018 года количество безработных в Узбекистане рассчитывается на основе методологии Международной организации труда. Это и является причиной резкого роста количества безработных в 2018 году и увеличения уровня безработицы с 5,8% до 9,3% соответственно по сравнению с 2017 годом. В период с 2011 по 2017 год уровень безработицы среди мужчин и женщин оставался почти одинаковым. Но к 2018 году уровень безработицы среди женщин был в 1,5 раза выше, чем среди мужчин, что есть 7,7% и 11,6% соответственно. К 2019 году разрыв увеличился более чем вдвое, а уровень безработицы среди женщин составил 12,8% и среди мужчин 6,0%. Также в 2018-2019 годах уровень безработицы среди женщин увеличился на 1,3%⁵².

Различия в уровне экономической активности женщин и мужчин в стране в основном объясняются взглядами, сформированными на основе национальных традиций, относительно большим количеством обязанностей женщин в домашнем хозяйстве и семье по воспитанию детей. В то же время относительно низкие показатели приема девушек в высшие учебные заведения в результате долгосрочных квот при поступлении в высшие учебные заведения значительно снижают их конкурентоспособность на рынке труда по сравнению с мужчинами.

⁵¹ Составлено автором на основании данных официального сайта Госкомстата Республики Узбекистан по гендерной статистике Узбекистана. [Электронный ресурс] <https://gender.stat.uz/uz/osnovnyye-pokazateli-uz/trud-uz/aktivnoe-naselenie-uz/1032-iqtisodiy-faol-aholi-soni> (дата обращения 05.06.2020)

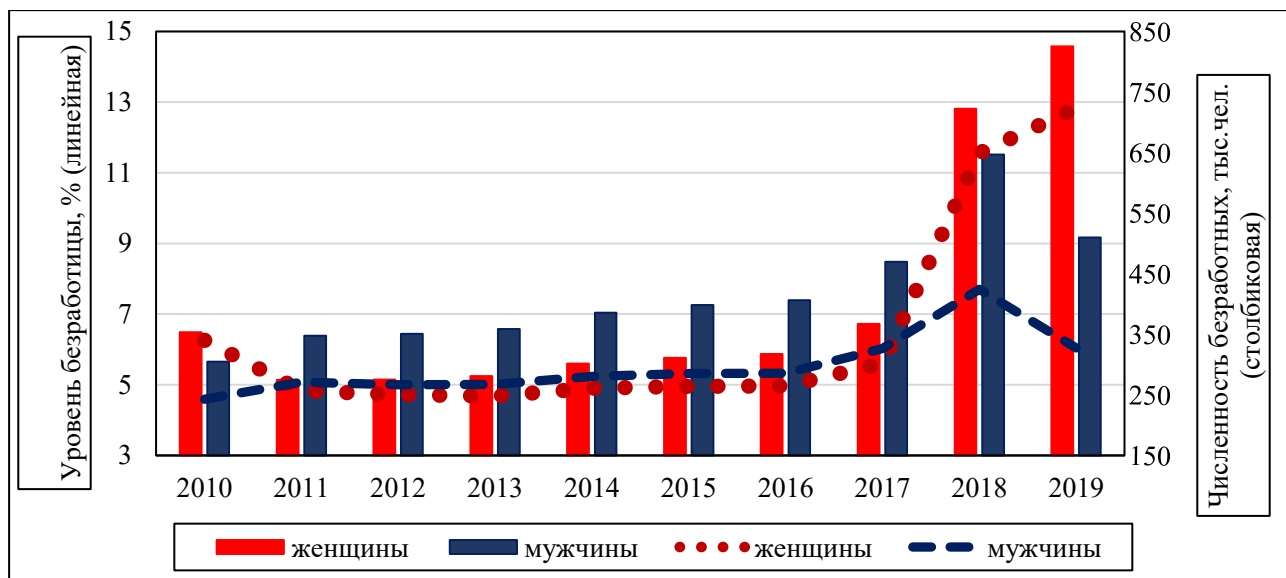
⁵² Государственный комитет по статистике Республики Узбекистан. Труд и занятость в Узбекистане 2016-2019. Статистический сборник. – Т., 2020. С.44.

Также наблюдается гендерная диспропорция в выборе профессии. В социально-гуманитарной сфере (педагогика, гуманитарные науки, искусство, журналистика) девушки составили 66,9%, в сфере здравоохранения и социальных услуг - 41,6%, в производственно-технической сфере - 17,8%.



Рисунок 4. Среднемесячная заработная плата в Узбекистане за 2010-2020 годы по видам экономической деятельности (в % к среднемесячной заработной плате)⁵³

Примечание. * Данные за 2020 год - среднемесячная заработная плата, рассчитанная за первое полугодие.

В то же время женщины работают в основном в таких сферах, как образование, здравоохранение, услуги по проживанию и общественное питание, где заработная плата является самой низкой. В сфере образования, где около 80% всей рабочей силы составляют женщины, среднемесячная заработная плата составляет около 80% от среднемесячной заработной платы, рассчитываемой на национальном уровне во всех сферах. Для сравнения: в этом году среднемесячная заработная плата в банковском деле, страховании и кредитовании составила 195,5% от среднемесячной заработной платы. Аналогичная ситуация наблюдалась в сфере

⁵³ Рассчитаны на основе данных официального сайта Госкомстата Республики Узбекистан. [Электронный ресурс] <https://stat.uz/uz/ochiq-ma-lumotlar> (дата обращения 05.06.2020)

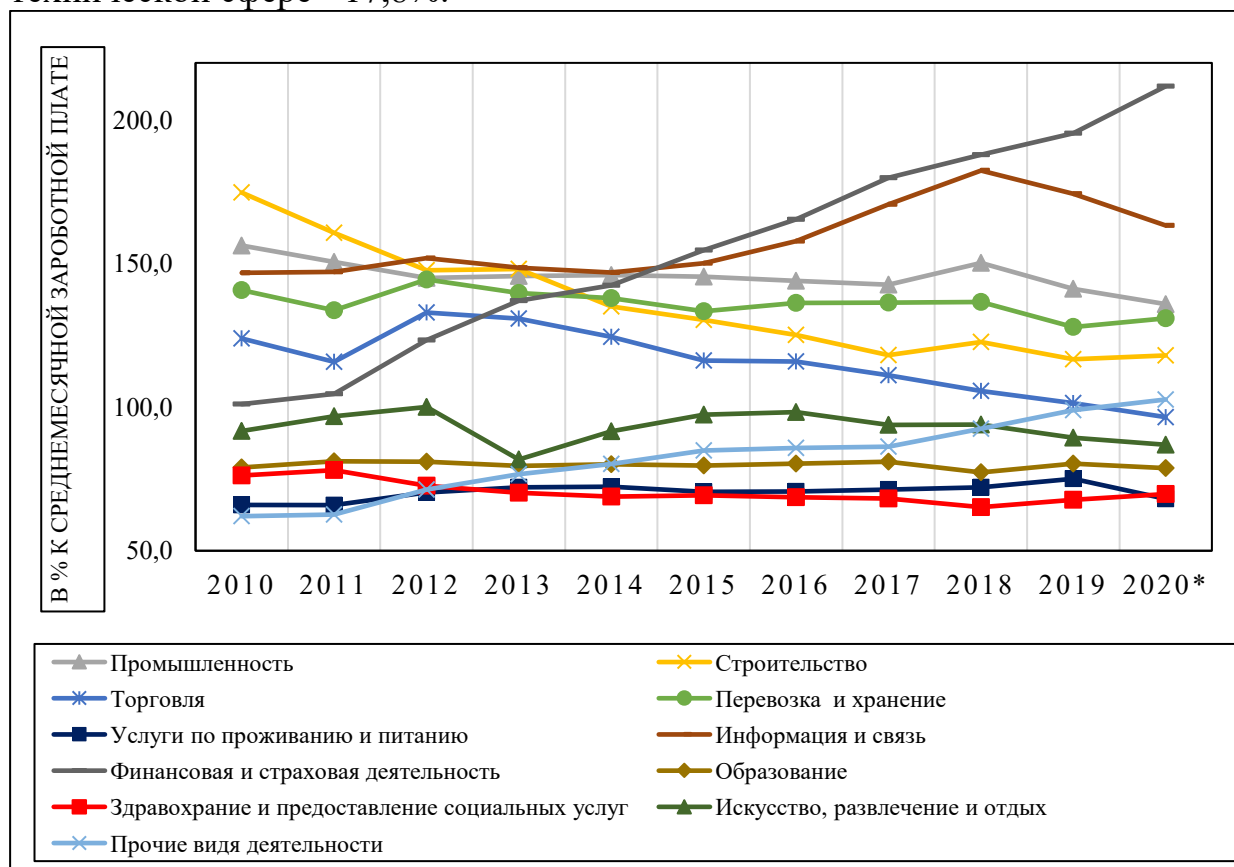
здравоохранения, где женщины составляли 76,8% от общей занятости при среднемесячной заработной плате 1 468 000 сумов, или 67,7% от среднемесячной заработной платы.

Реализация и расширение потенциала женщин, продвижение и обеспечение равенства с мужчинами во всех областях было одной из важнейших глобальных инициатив с середины прошлого века. В частности, пятая из целей в области устойчивого развития, которую в настоящее время поддерживают многие страны, напрямую направлена на обеспечение гендерного равенства и расширение прав и возможностей женщин. Цель состоит в том, чтобы решить проблемы ликвидации всех форм прямой и косвенной дискриминации в отношении женщин в глобальном масштабе, включая принятие и эффективное осуществление принципов, направленных на прекращение дискриминации в отношении женщин. Достижение гендерного равенства рассматривается как средство расширения свободы выбора женщин и мужчин и возможностей для личного развития. По всему миру проходят масштабные мероприятия.

В нашей стране тоже принимается много мер по реализации потенциала женщин. Узбекистан - первая страна Центральной Азии, подписавшая Конвенцию ООН о ликвидации всех форм дискриминации в отношении женщин (CEDAW) (31 августа 1995 г.). В республике ликвидация дискриминации в отношении женщин, обеспечение равенства между женщинами и мужчинами и расширение прав и возможностей всех женщин стали приоритетом государственной политики. Основным закон - Конституция Республики Узбекистан также включает отдельную статью о равенстве женщин и мужчин, предоставляющую женщинам равные правовые возможности для получения образования, профессиональной подготовки, стимулов для работы, занятости и продвижения по службе.

С целью поддержки женских инициатив и предотвращения всесторонней дискриминации впервые при Сенате Республики Узбекистан был создан специальный комитет по гендерному равенству. Среди основных задач которого установлены - реализация мер по профессиональной сегрегации, разрыву в заработной плате, увеличению доли женщин среди экономически активного населения и др.⁵⁴.

В последние годы в нашей стране приняты и усовершенствованы ряд нормативных правовых актов в этой сфере. В частности, Закон Республики Узбекистан «О защите женщин от притяжения и насилия», Закон Республики Узбекистан «О гарантиях равных прав и возможностей для женщин и мужчин». Данные законы стали важной правовой основой защиты прав женщин в республике. Они полностью описали все

⁵⁴ Постановление Президента Республики Узбекистан №ПП-4235 «О мерах по дальнейшему усилению гарантий трудовых прав и поддержке предпринимательской деятельности женщин». от 07.03.2019. [Электронный ресурс] Национальная база данных законодательства <https://lex.uz/docs/4230938> (дата обращения 20.07.2020)

ограничения и поведения, противоречащие гендерному равенству. Согласно нормативным правовым актам Республики Узбекистан различия в пенсионном возрасте мужчин и женщин, являющиеся особенностями охраны труда, не являются дискриминацией по признаку пола. Он также гарантирует равное участие женщин и мужчин в управлении общественными и государственными делами, избирательном процессе, здравоохранении, образовании, науке, культуре, труде и социальной защите, а также в других сферах государственной и общественной жизни.

В целях реализации равных прав и возможностей для женщин и мужчин в трудовых отношениях определено что работодатель обеспечивает⁵⁵:

- равные возможности для женщин и мужчин при найме на работу;
- равную заработную плату (вознаграждение) для женщин и мужчин, за равный труд и равный подход к оценке качества работы женщин и мужчин;
- равные возможности при продвижении по службе, переподготовке и повышении квалификации;
- равенство прав женщин и мужчин при прекращении трудового договора с работниками в связи с изменениями в технологии, организации производства и труда, сокращением объемов работ, повлекших изменение численности (штата) работников или изменение характера работ, либо ликвидацией предприятия, учреждения и организации с предоставлением преимущественных прав, установленных законом;
- внедрение и развитие практики социальной защиты и поддержки семьи, доступной для женщин и мужчин, имеющих детей, создание благоприятных условий труда для беременных и кормящих женщин;
- безопасные условия труда, обеспечивающие сохранение жизнедеятельности и здоровья женщин и мужчин, в том числе сохранение репродуктивной функции;
- недопущение неприемлемого обращения, приводящего к унижению достоинства лиц в трудовых отношениях, или созданию дискриминирующих условий труда;
- равные условия женщинам и мужчинам для совмещения трудовой деятельности, участия в общественной жизни с семейными обязанностями, в том числе посредством создания и расширения сети учреждений по уходу за детьми, предоставляющей возможности трудиться.

⁵⁵ Закон Республики Узбекистан № ЗРУ -562 «О гарантиях равных прав и возможностей для женщин и мужчин». от 02.09.2019 [Электронный ресурс] Национальная база данных законодательства, <https://lex.uz/ru/docs/4494873> (дата обращения 20.07.2020)

Пятая из пяти инициатив в области воспитания молодежи, выдвинутых президентом Ш.М.Мирзиёевым в стране, направлена на обеспечение занятости женщин. Обеспечение занятости женщин определено как один из приоритетов социально-экономического развития, важное условие повышения уровня и качества жизни населения. Только в 2018 году 245000 безработных женщин, выявленных в ходе посещений женскими комитетами и центрами занятости на дому, были трудоустроены на рабочие места, созданные на основе программ занятости. В микрорайонах сформированы адресные списки, около 10 тысяч женщин, живущих в тяжелых жилищных условиях, трудоустроены по специальной программе. По инициативе женских комитетов было создано более 2300 небольших мастерских за счет ремонта и ввода в эксплуатацию пустующих зданий, и около 16000 женщин были трудоустроены⁵⁶.

Отмечая важность принимаемых мер по повышению экономической активности женщин в республике, на наш взгляд, кроме того, было бы целесообразно реализовать следующие меры:

- Постоянное повышение месячной заработной платы в тех сферах, где работает большинство женщин, то есть в сфере образования и здравоохранения. Несмотря на повышения заработной платы в образовании, по данным Госкомстата о среднемесячной заработной плате в экономике в 2019 году и первом полугодии 2020 года, среднемесячная заработная плата в сфере образования составляет 78% от среднемесячной заработной платы по всем отраслям;

- углубление дальнейших мер по расширению возможностей женщин заниматься предпринимательской деятельностью, особенно в сельской местности;

- создание условий для расширения финансовых, региональных возможностей женщин для получения среднего специального и высшего образования с учетом реформ в системе образования, т.е. переходом на 11-летнее обязательное образование;

- организация в целях облегчения адаптации женщин к рынку труда после отпуска по уходу за ребенком в возрасте до 3 лет, а также создания условий для гармонизации образования и семейных обязанностей организация агентствами по трудоустройству программ профессионального обучения и дополнительного профессионального обучения, включая государственные дистанционные услуги;

- Восстановить систему ежемесячных пособий по уходу за детьми в возрасте до 2 лет всем матерям в целях социальной защиты и финансовой поддержки женщин, находящихся в декретном отпуске.

⁵⁶ 5-мақсад. Гендер тенгликни таъминлаш ва барча хотин-қизларнинг ҳуқуқ ва имкониятларини кенгайтириш [Электронный ресурс] <http://mineconomy.uz/uploads/5.pdf> (дата обращения 20.07.2020)

Использованные источники:

1. Закон Республики Узбекистан № ЗРУ -562 «О гарантиях равных прав и возможностей для женщин и мужчин». от 02.09.2019 [Электронный ресурс] Национальная база данных законодательства, <https://lex.uz/ru/docs/4494873> (дата обращения 20.07.2020)
2. Постановление Президента Республики Узбекистан №ПП-4235 «О мерах по дальнейшему усилению гарантий трудовых прав и поддержке предпринимательской деятельности женщин». от 07.03.2019. [Электронный ресурс] Национальная база данных законодательства <https://lex.uz/docs/4230938> (дата обращения 20.07.2020)
3. Официальный сайт Всемирного банка. [Электронный ресурс] <https://databank.worldbank.org/reports.aspx?source=2&series=SL.TLF.CACT.FM.NE.ZS#> (дата обращения 18.05.2020)
4. Официальный сайт Госкомстата Республики Узбекистан по гендерной статистике Узбекистана. [Электронный ресурс] <https://gender.stat.uz/uz/osnovnye-pokazateli-uz/> (дата обращения 05.06.2020)
5. Государственный комитет по статистике Республики Узбекистан. Труд и занятость в Узбекистане 2016-2019. Статистический сборник. – Т., 2020.
6. Официальный сайт Госкомстата Республики Узбекистан. [Электронный ресурс] <https://stat.uz/uz/ochiq-ma-lumotlar> (дата обращения 05.06.2020)
7. 5-мақсад. Гендер тенгликни таъминлаш ва барча хотин-қизларнинг ҳуқуқ ва имкониятларини кенгайтириш [Электронный ресурс] <http://mineconomy.uz/uploads/5.pdf> (дата обращения 20.07.2020)

*Алимова Д.
преподаватель*

Самаркандский государственный институт иностранных языков

АНАЛИЗ ПОНЯТИЯ "ВЕЖЛИВОСТЬ" В КОРЕЙСКОМ И РУССКИХ ЯЗЫКАХ

Аннотация: Данная статья посвящена понятию "Вежливость" в корейском и русских языках. В статье раскрываются виды вежливости. Данная статья ярко показывает культуру общения этих языков.

Ключевые слова: Вежливость, культура речи, речевой этикет, корейский язык, обращение.

*Alimova D.
teacher*

Samarkand State Institute of Foreign Languages

ANALYSIS OF THE CONCEPT OF "POLITENESS" IN KOREAN AND RUSSIAN LANGUAGES

Annotation: This article is devoted to the concept of "Politeness" in Korean and Russian. The article reveals the types of politeness. This article clearly shows the culture of communication between these languages.

Key words: Politeness, culture of speech, speech etiquette, Korean, address.

Вся наша жизнь, с момента рождения и до самой смерти, проходит среди таких же людей, как и мы сами. Личность любого из нас - это продукт общества, с которым мы взаимодействуем, и нашей собственной внутренней работы. Человек - это искаженное субъективным восприятием отражение окружающих его людей, у каждого из которых он невольно заимствуем какую-то черту, привычку или идею, и на их основе, в свою очередь, выстраивает свое поведение.

Представьте на миг, насколько велико ваше влияние на родных, друзей, коллег, которых вы видите каждый день, если даже случайные знакомые, встреча с которыми зачастую является для нас всего лишь кратким эпизодом, способны повлиять на наше настроение, а иногда и задать ритм целого дня[1].

Любому человеку приятно слышать добрые слова и видеть улыбки на лицах окружающих людей. Это ободряет, прибавляет уверенности. Человек всегда неосознанно хочет находиться рядом с теми, кто хорошо к нему относится. И в то же время никому не приятна грубость и агрессия по

отношению к нам. Ввиду этого, наш мир давно выработал систему норм и правил поведения в обществе для того, чтобы минимизировать отрицательное воздействие людей друг на друга.

Исходя из этого данная статья раскроит суть понятия "Вежливость" в двух совсем разных языках не только по звучанию, но и по своему происхождению вообще. Просмотрим речевой этикет корейского и русских языков[4].

Республика Корея является одной из стран Восточной Азии, в которой конфуцианство рассматривается как система моральных и этических ценностей, регулирующих в заимо отношения людей и побуждающая их быть последователями высшей мудрости, определяющей нормы справедливости, праведности и соответствия человека, какое бы место он не занимал в социально общественной иерархии.

Культура взаимоотношений корейцев выстроенная по вертикали - как совокупность высших норм мудрости и этики, в которой установлена иерархическая субординация ценностей и добродетелей, отражает, пять принципов отношений: императора и подданного, отца и сына, старшего брата и младшего брата, мужа и жены, двух друзей. А в русском же языке существует уважение обозначаемая словами Ты и Вы.

В настоящее время в корейском языке существуют:

1. Официально-вежливый стиль
2. Неофициально-вежливый стиль
3. Суффикс –시
4. Вежливые глаголы

1.Официально-вежливый стиль.

Используется в официальной обстановке, при обращении к вышестоящим людям. Начиная общение с корейцами, особенно если они старше по возрасту или выше по социальному положению, используется этот стиль.

В русском языке это считается обращением на вы. Если-же в русском языке меняется только интонация, то в корейском языке меняются окончания[5].

Для его образования используется окончание – ㅂ니다 (пишется ㅂ니다, в остальных окончаниях подобного рода последовательность ㅁㄴ записывается как ㅁㄴ) после гласных и - 습니다 после согласных[2:116].

Например:

가다 «идти» — 갑니다

적다 «записывать» — 적습니다

В вопросительных предложениях окончание меняется на -
ㅂ니까 после гласных и -습니까 после согласных. Например:

어디 갑니까? «Куда Вы идете?»

무엇을 읽습니까? «Что Вы читаете?»

В повелительных предложениях используются окончания -
십시오 после гласных и -으십시오 после согласных, например:

드십시오 «ешьте, пожалуйста».

앉으십시오 «садитесь, пожалуйста».

Для образования пригласительного наклонения используется
окончание -십시오 после гласных и -으십시오 после согласных. Например:

극장에 갑시다 «Давайте пойдем в театр».

그분에게 물어봅시다. «Давайте его спросим».

Обратите внимание, что при образовании этих форм у глаголов,
корень которых оканчивается на ㄹ, эта согласная исчезает (не только
фонетически, но и орфографически), например:

알다 «знать» — 압니다

살다 «жить» — 삽니다

2. Неофициально-вежливый стиль.

Также является вежливым, но звучит менее официально. Образуется
с помощью прибавления ко второй основе глагола окончания -요.
Например:

가다 «идти» — 가요

먹다 «есть» — 먹어요

В неофициально-вежливом стиле изменения глагола при вопросе,
повелении и приглашении не происходит. Например: 마셔요 «пью»,
«пейте?», «пейте», «давайте выпьем».

А здесь в русском языке считается на ты.

3. Суффикс -시.

Суффикс -시 употребляется в глаголах, относящихся к уважаемым
людям.

здесь - же мы можем привести пример, как в русском языке в конец
глагола добавляется окончание "-те" Например: 선생님은 신문을
보십니다 «Учитель читает газету». 가십니까? «Вы идете?»[3],

Этот суффикс также как и в русском языке говорящий не может использовать с глаголами, относящимися к себе.

В неофициально-вежливом стиле суффикс -시 сливается с окончанием -요 и образует окончание -세요. Например: 가세요. «Идите».

그분은 대사관에 가세요. «Он идет в посольство».

Использованные источники:

1. Балакай А.Г. Словарь русского речевого этикета. Проспект.Новокузнецк, 1993.
2. Рамстедт Г. Грамматика корейского языка Москва 1951
3. Мазур Ю.Н. Грамматика корейского языка (Морфология. Словообразование) 1960.
4. Богданов В. В. Речевое общение. Л., 1990.
5. Воробьев В.В. Лингвокультурология: Теория и методы. М.: Изд-во: РУДН, 2008.
6. Жукова И.Н. Словарь терминов межкультурной коммуникации / под ред. М.Г. Лебедько и З.Г. Прошиной. – М.: Флинта : Наука, 2013 г.

*Аманов О.А.
доцент кафедры инновационной экономики
Каршинский инженерно-экономический институт
Жонузиков Н.Б.
студент магистратуры
Каршинский инженерно-экономический институт*

ВЛИЯНИЕ ЦИФРОВОЙ ЭКОНОМИКИ НА РЫНОК ТРУДА

Аннотация: В статье рассматриваются основные показатели занятости на рынке труда, перспективы трансформации занятости населения в условиях перехода к цифровой экономике. Обозначены основные текущие проблемы на рынке труда и факторы, действие которых приведет к изменениям в будущем. Учёные и скептики, аналитики много говорят о том, что очень скоро человека можно будет заменить машиной, но работа для человека останется там, где он сможет работать лучше машины. Одновременно будет расти и число квалифицированных людей, которые не смогут самостоятельно приспособиться к изменениям.

Ключевые слова: цифровая экономика, цифровизация, рынок труда, занятость населения, уровень занятости и безработицы, производительность труда, информационно-коммуникационная сфера.

*Amanov O.A.
associate professor of the department of innovative economics
Karshi engineering economic institute
Jonuzokov N.B.
master's student
of the Karshi engineering economic institute*

IMPACT OF THE DIGITAL ECONOMY ON THE LABOR MARKET

Abstract: The article discusses the main indicators of employment in the labor market, the prospects for the transformation of employment in the context of the transition to the digital economy. The main current problems in the labor market and the factors that will lead to changes in the future are identified. Scientists and skeptics, analysts talk a lot about the fact that very soon a person can be replaced by a machine, but the work for a person will remain where he can work better than a machine. At the same time, the number of qualified people who will not be able to independently adapt to changes will also grow.

Key words: digital economy, digitalization, labor market, employment of the population, employment and unemployment rate, labor productivity, information and communication sphere.

Наш научный словарь в последние годы становится всё богаче новыми интернациональными словами, как например – интернет, электронное правительство, онлайн, ноу-хау, информационно-коммуникативные технологии, компьютерные технологии. На сегодняшний день особенно имеют большее значения для человечества новые словосочетания – цифровое телевидение, цифровая библиотека, цифровая экономика. В общем, если сказать это максимально упрощенно, то цифровизация и есть процесс внедрения компьютерных технологий и интернета во все сферы нашей жизни. Цифровизация продвигает к ближайшему пути развития стран в мире.

Если говорить об искусственном интеллекте или ноу-хау, электронных денежных переводах или технологических новинках, это очень современно и качественно. Но есть то, что беспокоит учёных, экономистов. Инновации внедрились в нашу жизнь сплошным потоком, и эти социальные последствия внедрения новых технологий иногда бывают тяжелыми. Например, раньше для потерявших рабочие места находилась новая работа, сейчас ситуация гораздо тяжелей.

Во-первых, новые технологии одновременно и очень быстро внедряются по многим сферам. К примеру, нас окружают роботизированные кассы во многих супермаркетах, в развитых странах автомобили с автопилотами уже ездят по обычным дорогам. Это означает, что очень скоро без работы останутся миллионы кассиров и шоферов. Уже сегодня регулярно в крупнейших банках развитых и развивающихся стран массово увольняют бухгалтеров, юристов, офисных работников, так как вместо них вполне могут работать роботы. Ещё один пример, бывший исполнительный директор McDonald's Эд Ренси в интервью американскому телеканалу Fox заявил: компании проще купить за \$35 тыс. робота, который будет делать гамбургеры и картошку фри, чем нанимать человека, обучать его, и платить ему \$15 в час. [1]

Во-вторых, проблема заключается в том, что исчезновение старых рабочих мест на сегодняшний день не сопровождается появлением новых – тысяча рабочих мест просто исчезают. Информационные технологии очень легко масштабируются.

К великому сожалению, массовая безработица здесь неизбежна. И накрыть общество развитых стран она может значительно раньше, чем предполагают сейчас скептики. Всем известно, как быстро распространялись мобильные телефоны, они потом быстро обрастали фотокамерами и полноценным доступом в интернет. Эксперты полагают, что роботизация начнёт массово уничтожать рабочие места уже

в ближайшие годы. А также, скорость технологических изменений возрастает так быстро, что многие из нас не успеваем идти параллельно со временем. Сегодня умные машины конкурируют с людьми, они побеждают в глазах работодателя.

Экономисты озабочены: станет ли искусственный интеллект причиной массовой безработицы? Здесь предстоит оценить влияние цифровой экономики на развитие трудовых ресурсов не только на уровне конкретных регионов или страны, а в целом на международном рынке с учётом миграционных процессов. Но стоит отметить, искусственный интеллект, не влияет на уровень массовой безработицы, но хотя в ближайшие годы. В нижеуказанной таблице мы можем это увидеть, стоит отметить «умные города» по уровню безработицы находятся в последних рядах.

Учёные и скептики, аналитики много говорят о том, что очень скоро человека можно будет заменить машиной, но работа для человека останется там, где он сможет работать лучше машины. Здесь мы согласны с тем, что главным всё-таки остаётся развитие человеческого капитала, но надо также отметить, что в этом случае ключевой проблемой станет – качество образования, изменение на рынке труда и т.д. Инновационное образование влияет на качество выпускников вузов, а инновационная экономика также грозит безработице, как и цифровая. Инновации не только сокращают потребность в тех или иных профессиях, они меняют целые рынки.

По нашим прогнозам, очень скоро (2021-2025) будет накапливаться критическая масса специалистов, не нужных рынку, но обладающих дипломами престижных вузов по модным на момент поступления специальностям. Одновременно будет расти и число квалифицированных людей, которые не смогут самостоятельно приспособиться к изменениям. Изменения на рынке труда – наглядный пример влияния цифровых технологий на нашу жизнь.

Преодоление кадрового голода и низкий уровень безработицы надо обеспечить двумя способами, во-первых, для новых кадров это радикальное изменение учебных планов, их максимальная адаптация под индивидуальные способности студента. Во-вторых, для людей, имеющих квалификацию, нужна система переподготовки для работы в цифровой экономике.

Задачи, которые предстоит нам решить, сформулированы достаточно чётко:

1. Надо сформировать адекватную систему профессиональных компетенций в части знаний и навыков по информационно-коммуникативным технологиям для всех типов профессий и специальностей;

2. С учётом постоянных изменений и развитием ИКТ эту систему надо сделать максимально гибкой, «самонастраивающейся»;

3. Нужно выстроить систему постоянного переобучения преподавательского состава.

Чтобы система заработала, новый подход к обучению должен поменяться на всех уровнях образовательного процесса. Базой должна стать общая цифровая грамотность, на ней – строиться система прикладных практических занятий. Нужна плотная интеграция с компаниями-лидерами рынка, которые должны формулировать потребности, определять набор компетенций, предоставлять возможности для стажировок, давать обратную связь по качеству подготовки специалистов[2].

Главное – это понять место человека, в экономике будущего, выработать действия игроков рынка труда по отношению к человеку, роль и место которого в процессе труда радикально меняется. И в первую очередь здесь потребуется совсем другое регулирование, появление более гибкого законодательства. Из-за внедрения цифровой экономики, необходимо вносить изменения не только в Трудовой кодекс, но и подзаконные акты по вопросам трудового права. Большим прорывом стали бы законодательные изменения, позволяющие автоматизировать кадровое делопроизводство, перевести в электронный вид трудовую книжку, трудовой договор и многие другие документы. В итоге освободилось бы много времени и у кадровиков, и у работников.

В нашей республике до внедрения цифровой экономики существуют некоторые проблемы, которые должны быть решены. На преобладающем пока начальном этапе структурной перестройки экономики преобладает локальный уровень рынка труда. Это связано с низкой территориальной мобильностью населения, низким уровнем жизни основной его части, высокой стоимостью транспортных расходов, отсутствием развитого рынка жилья. В этих условиях чрезвычайно трудно сбалансировать спрос и предложение на рабочую силу в пределах конкретных локалитетов, что приводит к достаточно резким различиям в уровне безработицы. Региональный уровень рынка труда в Узбекистане представлен, прежде всего, субъектами областей. Такие субъекты обладают не только территориальным хозяйственным характером, региональной системой расселения населения, но и соответствующими органами управления для осуществления собственной региональной политики в сфере рынка труда, в том числе и трудовой занятости населения. По сравнению с другими областями, этого экономического района она наиболее контрастна по специализации. А также по уровню развития хозяйства, особенностями его трансформации, расселения населения, обеспеченности кадрами [3].

В условиях растущей конкуренции на рынке труда в Узбекистане всё так же востребованы высококвалифицированные кадры. 2017 год стал значимым для рынка труда Узбекистана. Курс на эффективность затрат всё ещё продолжается. Компании стремились привлечь лучших кадров, а действующим поставили условие – развиваться, работать над собой или

просто уйти. При этом в некоторых сферах даже самых лучших заменили роботы-алгоритмы, для которых компании в ряде отраслей уже подготовили подходящие условия, а новые бизнес проекты предложили тысячи рабочих мест.

Исследования показали, что современный рынок труда имеет свои тенденции на сегодняшний день:

- смена работы. Многие специалисты неохотно меняют место работы, а поиск нового работодателя ведут пассивно.

- срок поиска работы вырос в 1,5 раза. Из-за жёсткой конкуренции и количества кандидатов компаниям сложнее сделать выбор, при этом количество этапов подбора при найме растёт.

- работодатели всё больше отдают предпочтение кандидатам с опытом работы, впоследствии, конкуренция среди соискателей выросла в 2 раза.

- компаниям сложно найти хороших специалистов. Профессионалов всё реже переманивают заоблачными зарплатами, и они неохотно меняют место работы, долго принимая решение о смене работодателя.

- на предприятиях выросла ценность отдельно взятого сотрудника. С учетом сложностей подбора, сегодня многие работодатели готовы обучать лучших работников для того, чтобы продвигать их внутри компании.

- время сокращений проходит. В 2015–2016 годах компании предпочитали сократить часть сотрудников, чтобы сохранить уровень зарплат. В 2017 году оптимизация трат на персонал значительно сократилась.

- под угрозой остались страховые агенты, кредитные специалисты и операционисты в банках. В связи с инфляцией упало количество покупок страховых продуктов, а вместе с ним и количество вакансий страховых агентов. За последние два года банковский сектор расширился незначительно, а количество молодых специалистов выросло в 1,5 раза, соответственно повысив конкуренцию на имеющиеся рабочие места [4].

Занятость характеризует различные формы участия трудоспособного населения в общественной деятельности с получением соответствующих доходов. Рынок труда складывается под влиянием факторов, определяющих спрос и предложение рабочей силы. Факторы предложения рабочей силы включают демографическую ситуацию, гендерно-возрастную структуру населения, динамику трудоспособного, занятого, безработного населения, внутреннюю и внешнюю миграцию, уровень образования и др. факторы спроса на труд обуславливаются динамикой экономического роста, ввода новых предприятий, отраслевого и территориального развития, мер фискальной, монетарной, инвестиционной политики и др.

Особенности переходного периода и демографической ситуации определили модель политики занятости в Узбекистане: модель оперативного реагирования на высокий уровень предложения рабочей

силы. Для снятия напряженности на рынке труда государство ежегодно разрабатывает и реализует Программы создания рабочих мест и обеспечения занятости. Однако административный характер их реализации, который выражается в создании «брутто» рабочих мест «любой ценой» без должного внимания их устойчивости, а также отсутствие конкретных механизмов предоставления льгот, субсидий, источников финансирования проектов по созданию рабочих мест, приводит к несистемному решению проблем занятости [5].

Таблица 1.
Вызовы в сфере занятости и последствия их влияния на экономику Узбекистана
[6]

<i>Риски и проблемы развития рынка труда в Узбекистане</i>	<i>Наиболее вероятные последствия для экономики и перспектив роста её конкурентоспособности</i>
Значительное превышение предложения рабочей силы над спросом	Рост безработицы (особенно молодежной и женской) и социальных проблем. Сохранение высокого уровня трудовой миграции (в том числе молодежи, имеющей высшее и среднее специальное образование)
Низкая эффективность новых рабочих мест создаваемых в секторе малого частного бизнеса	Консервация технологической отсталости, негативное влияние на налоговый потенциал и, соответственно, снижение финансовых возможностей государства по решению социальных проблем.
Высокая доля занятых в неформальном секторе экономики	Слабые перспективы устойчивого долгосрочного экономического роста, усиление макроэкономических дисбалансов (налично-денежное обращение, валютные операции и др.) консервация технологической отсталости, ухудшение криминогенной ситуации
Существенное отставание по уровню эффективности использования трудовых ресурсов по сравнению с передовыми развивающимися странами мира	Высокий уровень производительности труда ассоциируется с высокой конкурентоспособностью экономики и ее привлекательностью для иностранных инвесторов. Сохранение сложившегося разрыва ухудшит позиции Узбекистана в конкурентной борьбе за иностранные инвестиции.

<p>Запаздывающая динамика роста производительности труда по отношению к росту реальной заработной платы</p>	<p>Рост доходов населения является одним из главных факторов стимулирования совокупного спроса и, соответственно, темпов экономического роста. Однако устойчивый рост конкурентоспособности невозможен в условиях, когда темпы роста зарплаты превышают рост производительности труда. В такой ситуации одновременно с подрывом конкурентоспособности усиливаются инфляционные риски, т.к. спрос на товары и услуги начинает обгонять их предложение.</p>
<p>Дефицит финансовых средств (частных и государственных) для целей создания новых рабочих мест</p>	<p>В условиях отсутствия устойчивого спроса на рабочие места в несырьевом секторе экономики, государство распределяет имеющиеся инвестиции в сырьевой сектор (нефтегазовая сфера, первичная обработка минеральных ресурсов), которые привлекательны для иностранных инвесторов, но которые не решают проблемы эффективной занятости трудоспособного населения и роста конкурентоспособности национальной экономики.</p>

В Узбекистане в ближайшие годы настанет пора думать о внедрении цифровой экономики, так как волна инноваций доходит из стран мира, готовых внедрить инвестиции в виде инноваций. По этому делая вывод, мы должны очень быстро усвоить новшества, иметь инновационное мышление, учить и готовить с раннего возраста детей к новым профессиям, быть готовы к изменениям науки и техники.

Использованные источники:

1. Н.Дембинская. Вкалывают роботы: кто останется без работы через 5 лет // Риа Новости, 2017
2. Из доклада Д.Пескова по программе «Цифровая экономика», // 2017, июль
3. О.Ю.Сушкова. Рынок труда и занятости населения - Воронеж, 2008
4. Информационный бизнес портал Узбекистана. Тенденции рынка труда Узбекистана. 2017
5. О.В.Заяц. Занятость населения и её регулирование. –Владивосток, 2003
6. Занятость в Узбекистане: вызовы и перспективы. Центр экономических исследований. 2013-2015
7. Курбанов Алишер Бобокулович Роль малого бизнеса в инновационной деятельности // Economics. 2020. №1 (44). URL:

<https://cyberleninka.ru/article/n/rol-malogo-biznesa-v-innovatsionnoy-deyatelnosti> (дата обращения: 21.12.2020).

8. Курбанов Алишер Бобокулович Роль кооперации в формировании аграрной собственности // Economics. 2020. №4 (47). URL: <https://economic-theory.com/images/PDF/2020/47/the-role-of-cooperatio.pdf>

9. Kh, Abdurakhmanov K., et al. "Labor migration and its impact on employment of population." Международный научно-исследовательский журнал 4-2 (82) (2017). URL: <https://research-journal.org/economical/labor-migration-and-its-impact-on-employment-of-population/> doi:10.23670/IRJ.2017.82.4.028

10. Amanov O.A. Ways of regulation, condition and employment trends of the population of the republic of Uzbekistan. Journal of Management Value & Ethics. India. ISSN: 2249-9512 Vol 8, №2, 2018.–P.98-106. URL: https://www.jmveindia.com/journal/APRIL-JUNE_18.pdf

*Аманов О.А.
доцент кафедры инновационной экономики
Каршинский инженерно-экономический институт
Чуллиев Ж.К.
студент магистратуры
Каршинский инженерно-экономический институт*

ПОВЫШЕНИЕ ЭФФЕКТИВНОСТИ ИСПОЛЬЗОВАНИЯ ЧЕЛОВЕЧЕСКОГО КАПИТАЛА

Аннотация: в этой статье освещаются важные аспекты человеческого капитала для экономики. Источниками инвестиций в человеческий капитал являются семья, бизнес и государственные расходы. При этом учитываются расходы на воспитание и образование ребенка в семье, что он будет получать высокий доход в результате своей будущей продуктивной работы.

Компания также заинтересована в инвестициях в человеческий капитал. Потому что сотрудник с высокими знаниями, навыками и способностями вносит значительный вклад в увеличение доходов работодателя в результате эффективной работы на предприятии.

Ключевые слова: занятость, безработица, человеческий капитал, развитие человеческого капитала, неформальная занятость

*Amanov O.A.
associate Professor of the Department of Innovative Economics
Karshi Engineering Economic Institute
Chulliev J.K.
master's student
of the Karshi engineering economic institute*

INCREASING THE EFFICIENCY OF HUMAN CAPITAL USE

Abstract: This article highlights important aspects of human capital for the economy. Family, business and government spending are sources of investment in human capital. This takes into account the costs of raising and raising a child in a family, so that he will receive a high income as a result of his future productive work.

The company is also interested in investing in human capital. Because an employee with high knowledge, skills and abilities makes a significant contribution to increasing the employer's income as a result of effective work in the enterprise.

Key words: employment, unemployment, human capital, human capital development, informal employment

Человеческий капитал – это знания, навыки и здоровье, которые люди аккумулируют в течение своей жизни, что позволяет им реализовывать свой потенциал в качестве полезных членов общества. Инвестиции в людей на основе улучшения питания, здравоохранения, предоставления качественного образования, создания рабочих мест и обучения профессиональным навыкам способствуют развитию человеческого капитала, а это является основным условием, позволяющим покончить с крайней бедностью и сформировать более социально сплоченное общество.

Экономический рост и развитие зависят как от человеческого капитала, так и от материальных активов, а также от факторов, влияющих на производительность. Инвестиции в эти сферы дополняют и усиливают друг друга. Производительность людских ресурсов зависит от наличия материальных активов, таких как объекты инфраструктуры, оборудование и стабильная, эффективно управляемая экономика. В свою очередь, физически здоровые и образованные люди могут больше зарабатывать и больше инвестировать в материальные активы экономики.

По инициативе Президента Республики Узбекистан была разработана стратегия развития Республики Узбекистан в 2017-2021 годах в пяти направлениях.

В данной стратегии были рассмотрены планы разностороннего развития регионов с помощью осуществление более 25 инвестиционных проектов за счет которых образуется более 256,4 рабочих мест, и с её помощью обеспечить выполнение государственной программы по занятости населения. В истоках этих комплексных мер лежит глубоко обдуманная политика и точные цели государства. Разрабатывается планирование создания 46,8 новых рабочих мест в регионах где уровень безработицы самое высокое, обеспечение кредитами более 10 тысяч выпускников образовательных учреждений для занятия предпринимательством. Особенно эта политика касается и оказывает положительную значение для тех которые закончили профессиональные колледжы и не могут найти работу. [1]

Как подчеркивает Президент Республики Узбекистан Ш.М.Мирзияев: - “В нашей стране каждый год потребность на рабочие места составляет 1,5 миллионов человек, но при этом центры по оказание помощи занятости населения регистрируют 248 тысяч человек или 16,5 процентов человек обеспеченных рабочими местами”. [2]

В сегодняшний день в нашей стране в рамках выполнения государственной программы по “Образование рабочих мест и обеспечения занятости населения” были даны прогнозные параметры потребностей на рабочие места по отраслям и регионам страны, особенно были подчеркнуты

молодежь которые в первые приходят в рынок труда, учитывались кординальные экономические изменения и отрасли требующие много трудовых ресурсов которые были модернизированы и в итоге которого сотрудники остались без работы, а так же потребности на рабочую силу в отраслях как сервисное обслуживание, сельское хозяйство, промышленность, предпринимательство и бизнес.

В Узбекистане самой главной проблемой занятости считается скрытая занятость населения, которая в свою очередь становится главным фактором развития теневой экономики. Потому что:

- Неформальная занятость не имеет ни какой экономической основы;
- Неформальная занятость социально не защищена и не имеет гарантии долговечности доходов;
- Из-за принятий нормативно-правовых реформ, изменения социально-экономической среды и инфраструктуры производства занятые в этом секторе теряют рабочие места;
- Неформальная занятость имеет характер сезонности и временности, в случае изменения погоды, климата и сезона он остается без работы;
- В этой форме занятости ни какие налоги и платежи не выплачиваются в государственный бюджет;
- Возникнут проблемы связанные с внебюджетными организациями Пенсии и накопительным фондом . повышаются затраты относительно Пенсионного фонда.

По нашему мнению, надо принимать комплексные меры по социальной защите населения, учитывая уровень жизни населения и изменять обстановку на рынке труда. Если обеспечить мощную социальную защиту и гарантию стабильности то можно достичь эффективности разработанной программы, механизма работы и развития экономики. В наши дни становитя актуальным объективная разработка мощной комплексной меры по обеспечению социальной защиты населения в рыночной экономике. Мы должны понимать что кординальные изменения в экономике влияет на жизненный уровень населения , и из за них без условно возникают проблемы в жизни. Из за этого мы не должны забывать о сильной социальной защите. Мы должны разработать точные направления и средства социальной защиты.

Анализ опыта регулирования государством рынка труда сельской местности показывает что мы должны учитывать следующие результаты:

- проведение государственной политики и комплексных мер показателей по государственному спросу на трудовые ресурсы, их предложения, цены, количества и качества, а также в текущести в определенных целях;

- предоставление льготных условий для работодателей, с помощью налога, финансово-кредитных и инвестиционной политики образовать новые рабочие места и обеспечение жизнедеятельности эффективно работающих отраслей;

- разработать и совершенствовать альтернативные формы занятости и обеспечение программирования самозанятости населения;

- снижение уровня депрессивной безработицы и создать экономические условия социальной защиты безработного населения.

В Узбекистане создание новых рабочих мест, особенно в сельской местности является главным социально – экономической задачей государства. По расчетам экономистов, рост объема внутренней валовой продукции в 4,0 – 6,0 % дает возможность роста занятости населения в 2,7%. Развитие Малого бизнеса в этой степени дает рост занятости в 7,9%.

Малый бизнес и предпринимательство является показателем большого спроса на объем труда, определяется как отрасль образующий социальный труд и имеет большое значение в этой отрасли. В том числе:

- Малый бизнес и предпринимательство имея малый капиталоемкость владеет привилегией быстрого образования новых рабочих мест. То есть, в малых предприятиях расходы капитала на одно рабочее место гораздо меньше чем на крупных предприятиях;

- для экономически активного населения занятость в сфере малого бизнеса является выгодным. Оно дает возможность самовыражению, активности и творческому подходу к работе, и осуществления новых идей;

- в малых предприятиях занятость можно организовать в соответствии возможностей: не полная рабочая неделя или неполный рабочий день, по совместительству, скользящему графику и т.д.

В процессе проведения анализа мы пришли к выводам что особенностью трудового рынка сельской местности для фермерских хозяйств, семейного бизнеса, малых предприятий и минифирмам является постоянной и эффективной, а для дехканских хозяйств является сезонной и непостоянной .

Исходя из вышеуказанных фактов, в место заключения мы можем сказать, что политика государства обращенная на повышения уровня занятости населения рассматривает следующие направления:

- повышение спроса на рабочую силу за счет образования новых рабочих мест и удержания существующих эффективных рабочих мест;

- образования конкурентноспособного предложения рабочей силы на трудовом рынке за счет повышения профессиональной подготовки кадров;

- образование квот для неконкурентноспособного слоя населения на трудовом рынке (инвалиды, женщины, подростки и др.) ;

- повышение заинтересованности в создании новых рабочих мест работодателя ;

- заинтересованность в обеспечении собственной самозанятости населения;
- внедрение альтернативных вариантов создания занятости населения;
- регулирование процессов миграции рабочей силы;
- социальная защита безработных;
- в целях улаживания существующих проблем обеспечения рабочими местами выпускников ВУЗов, профессиональных колледжей , организовать информационно- консалтинговые услуги, открыть интернет страницы для интерактивного опроса и определять направления оказываемой помощи ;
- для выпускников учебных заведений создать электронную ярмарку рынка труда;

Эта трудовая ярмарка должна действовать постоянно и она должна своевременно и регулярно пополняться информацией о выпускниках учебных заведений страны.

Использованные источники:

1. Указ Президента Республики Узбекистан от 7 февраля 2017 года № ПФ-4947 «О Стратегии действий по дальнейшему развитию Республики Узбекистан».
2. Ш.М. Мирзиёев «2019 год - Год активных инвестиций и социального развития». Обращение к Олий Мажлису от 28 декабря 2018 г. - Т.: Народное выступление, 29 декабря 2018 г., № 271-272
3. Kh, Abdurakhmanov K., et al. "Labor migration and its impact on employment of population." *Международный научно-исследовательский журнал* 4-2 (82) (2017). URL: <https://research-journal.org/economical/labor-migration-and-its-impact-on-employment-of-population/> doi:10.23670/IRJ.2017.82.4.028
4. Курбанов Алишер Бобокулович РОЛЬ МАЛОГО БИЗНЕСА В ИННОВАЦИОННОЙ ДЕЯТЕЛЬНОСТИ // *Economics*. 2020. №1 (44). URL: <https://cyberleninka.ru/article/n/rol-malogo-biznesa-v-innovatsionnoy-deyatelnosti> (дата обращения: 14.12.2020).
5. Курбанов Алишер Бобокулович РОЛЬ КООПЕРАЦИИ В ФОРМИРОВАНИИ АГРАРНОЙ СОБСТВЕННОСТИ // *Economics*. 2020. №4 (47). URL: <https://economic-theory.com/images/PDF/2020/47/the-role-of-cooperatio.pdf>
6. Amanov O.A. Ways of regulation, condition and employment trends of the population of the republic of Uzbekistan. *Journal of Management Value & Ethics*. India. ISSN: 2249-9512 Vol 8, №2, 2018.–P.98-106. URL: https://www.jmveindia.com/journal/APRIL-JUNE_18.pdf

*Арутюнян Д.В.
студент
Брюханова Г.Д.
профессор
СГУ
г. Сочи*

ЭКОЛОГИЧЕСКИЙ ТУРИЗМ КАК ФАКТОР УСТОЙЧИВОГО РАЗВИТИЯ

Аннотация: Экотуризм — это устойчивый и природно-ориентированный туризм и рекреация. Устойчивость же в туризме подразумевает положительный общий баланс экологических, социально-культурных и экономических воздействий туризма, а также положительное воздействие посетителей друг на друга. Таким образом, те виды туристической деятельности, которые имеют наиболее высокий суммарный положительный эффект с точки зрения экологии, экономики и социального развития, являются более устойчивыми.

Ключевые слова: экотуризм, экотур, дестинация, национальные парки, особо охраняемые территории, устойчивый туризм

*Arutyunyan D.W.
student
Bryuhanova G.D.
professor
SSU
Russia, Sochi*

ECOTOURISM AS A FACTOR OF SUSTAINABLE DEVELOPMENT

Abstract: Ecotourism is sustainable and nature-oriented tourism and recreation. Sustainability in tourism implies a positive overall balance of environmental, socio-cultural and economic impacts of tourism, as well as the positive impact of visitors on each other. Thus, those types of tourism activities that have the highest overall positive effect in terms of ecology, economy and social development are more sustainable.

Keywords: ecotourism, ecotourism, destination, national parks, specially protected areas, sustainable tourism

Экологический туризм - относительно новое явление в мировой туристской деятельности.

Началом формирования концепции экотуризма следует считать 80-е годы, когда в печати появились исследования на эту тему, связанные с работами западно - германских и швейцарских ученых. Основная причина обращения к экологическому туризму коренится в неотрегулированности отношений в системе «туризм - экология».

Существуют два основных подхода к выделению экологического сектора туризма.

В первом случае экотуризмом называют туризм, главным объектом которого является дикая природа. При этом большинство авторов отмечают сложность проведения границы между природой и традиционной культурой и наряду с природой включают последнюю в объекты экотуризма. Но даже в этом случае емкость понятия "экотуризм" полностью не исчерпывается. Широкое распространение получает туризм с целью отдыха на природе на территориях, измененных человеком. Это особенно характерно для США и стран Западной Европы, где коренных ландшафтов практически не сохранилось, а высокая потребность общения с природой удовлетворяется населением на территориях со вторичной квазиприродой. Такой туризм часто причисляется к разряду экологического, а его значение для охраны и восстановления среды, народных традиций и экологизации экономического развития становится в некоторых регионах решающим. В качестве примера можно привести агротуризм (посещение ферм и деревень с целью окунуться в атмосферу сельского образа жизни).

Другой подход - рассматривать экологический туризм как пример (вид) устойчивого туризма - это более правильно, так как этот вид туризма основывается и успешно реализует на практике главные принципы концепции устойчивого развития, как-то природопользование, не приводящее к деградации ресурсов, поскольку для восстановления и охраны последних используется часть выгод от его развития. При этом подходе объекты туризма могут быть как природного, так и искусственного происхождения.

Важным вопросом является разграничение двух распространенных сейчас терминов о туризме: устойчивый и экологический. Однозначного понимания, как при многих спорных и широких по охвату вопросов, нет. Но преобладающей сейчас является другая точка зрения. Под экологическим туризмом понимается форма (вид) туризма с определенными свойствами (какими - приведено выше), есть определенные требования, прежде всего уникальность природного или природно-культурного явления, соблюдаться строгие правила по бережному отношению к окружающей среде. Устойчивый туризм - это не какой то вид, это направление развития основанное на принципах концепции устойчивого развития. Такой туризм, который удовлетворяет все существующие потребности, но при этом развивается таким образом, чтобы обеспечить такими же возможностями последующие поколения. Включает и ресурсосбережение, как бережное

отношение к биоразнообразию, так и сохранности всей окружающей среды, учитывает все культурные и социальные отношения.

Поэтому любой экотуризм можно назвать примером устойчивого туризма, устойчивый туризм может быть любого другого вида, не обязательно экологическим.

Главной движущей силой бурного развития экотуризма является быстро растущий спрос на рекреацию на природе, который определяется увеличением несоответствия среды обитания современного человека его физиологическим и психологическим потребностям. Удовлетворение этого спроса и, следовательно, успех развития экотуризма, как никакой другой отрасли, зависит от качества окружающей среды, поскольку туристами ценится именно ее первозданность. Поэтому экологический фактор естественным образом становится экономической категорией: поддержание качества и первозданное окружающей среды (признак устойчивости) экономически выгодно в отличие, например, от пляжного туризма, для организации которого не нужна дикая природа, а достаточно насыпных пляжей или даже бассейнов. Эта выгода проявляется на относительно небольших промежутках времени, тогда как в других отраслях отрицательный экономический эффект от деградации природной среды чаще всего наступает не так скоро, обычно уже по истечении срока окупаемости проектов.

Таким образом, **экологический туризм** - это природоориентированный устойчивый туризм. Обе его характеристики определяются объективными причинами: природная ориентация - особенностями туристского спроса, а устойчивость - экономической выгодой поддержания качества окружающей среды.

Экотуризм сегодня - это комплексное, междисциплинарное направление, обеспечивающее взаимосвязь интересов туризма, охраны природы и культуры.

Использованные источники:

1. Александрова А.Ю. Международный туризм. М., 2016
2. Гайдукевич Л.М., Хомич С.А., Аношко Я.И. География международного туризма: Страны СНГ и Балтии. - М, 2016. - С. 25.
3. Болотова Е.В. Рекреационное ресурсоведение: Учеб. пособие./Е.В. Колесникова -М.: РМАТ, 2012 – 156 с.
4. Дроздов А.В. Основы экологического туризма. - М.: «Гардарики», 2005. - С. 187.
5. Дроздов А.В., Басанец Л.П. Природопользование и устойчивое развитие. Мировые экосистемы и проблемы России. - М.: Товарищество научных изданий КМК, 2006. - С. 118.
6. Дроздов Н.В. Экологический императив и рекреационная география //Известия РАН. Серия географическая. 2008. №4. С. 91-97

7. Маринин М.И. О проблемах российского туризма // Экономика и жизнь. - 2005. № 31.
8. Официальный сайт федерального агентства по туризму Российской Федерации // www.russiatourism.ru/news/334.sm

*Асадуллаева Д.А., магистр
кафедры лесного хозяйства
Ташкентский государственный аграрный университет
Каландаров М.М.
профессор кафедры лесного хозяйства
Ташкентский государственный аграрный университет*

ИЗУЧЕНИЕ ИНТРОДУКЦИИ КИПАРИСА ВЕЧНОЗЕЛЕНОГО В УСЛОВИЯХ УЗБЕКИСТАНА

*Аннотация: Статья весьма актуальна на его изложена интродуцированные вечнозеленые растения в условиях Республики. *C. sempervirens*, особенно его пирамидальная форма, широко применяется и заслуживает еще большего распространения в аллеиных посадках, обсадах дорог, в группах, солитерных посадках; из него удаются прекраснейшие монументальные живые изгороди, стены и защитные полосы. Так как кипарис растет в густом стоянии он вынослив к подстрижке. А также при своём быстром росте перспективен и для лесного хозяйства на юге и Центральной части Узбекистана. Анализ и обобщение производственного опыта создания насаждений в условиях Республики, что кипарис вечнозеленый, в основном применяется в городских посадках вдоль улиц и каналов, автомобильных дорог, тротуаров и в некоторых случаях в виде рожи на небольших площадях.*

Ключевые слова: континентальность климата, комфортность, засухоустойчивость, долговечность, эфирные масла.

*Asadullaeva D.A., master
of the Department of Forestry
Tashkent State Agrarian Universitet
Qalandarov M.M.
Professor Head of the Department of Forestry
Tashkent State Agrarian Universitet*

STUDY OF INTRODUCTION OF CUPRESSUS SEMPERVIRENS IN CONDITION OF UZBEKISTAN

*Annotation: The article is actual as it outlines the introduced evergreens growth in the conditions present in the country. *C. sempervirens*, especially its pyramidal shape, is widely used and deserves to be even more widespread in alley plantings, road casing, group planting, specimen plantings; it produces the finest monumental hedges, walls, and protective strips. Since cypress grows in a dense, it is welcome to cut the branches. And, with its rapid growth, it is also promising*

for forestry in the south and central part of Uzbekistan. Analysis and generalization of production experience in the creation of plantations in the Republic, that evergreen cypress is mainly used in urban plantings along the sides of the street and canals, highways, sidewalks, and, in some cases, grown in small areas.

Key words: continental climate, comfort, drought tolerance, durability, essential oils.

Актуальность темы. Узбекистан отличается большим разнообразием природных условий. Для всей республики характерно резко выраженная континентальность климата, высокие летние и низкие зимние температуры, сухость воздуха, резкие колебания суточных температур, большая годовая сумма положительных температур (4000-6000°C), низкая сумма осадков за вегетационный период (20-130 мм) и огромная испаряемость на преобладающей части территории летом часто дуют горячие ветры, а зимой холодные. Все эти климатические факторы не очень благоприятны для зелёного строительства, и если не подойти к посадкам тщательно, то они отрицательно сказываются на росте и развитии деревьев, кустарников и цветов.

Зеленые насаждения играют огромную роль в формировании архитектурно - художественного облика любого населенного пункта, придавая ему индивидуальные своеобразные черты. Система озеленения выполняет очень важные санитарно-гигиенические и микроклиматические функции, а также повышают уровень комфортности окружающей среды.

Одной из актуальнейших задач в деле улучшения и охраны окружающей среды в городах и населенных пунктах Узбекистана является расширение работ по зеленому строительству. Однако, в связи с этим, необходимо учитывать, что в условиях резко континентального климата Узбекистана в частности, озеленительный ассортимент, помимо высоких декоративных качеств, должен обладать достаточной зимостойкостью (абсолютный минимум минус 29,9°C), жаростойкостью (абсолютный максимум+43 С) и быстрым ростом.

Из таких декоративных растений для Узбекистана является Кипарис вечнозелёный (*Cupressus sempervirens* L). Родина кипариса- Малая Азия, северный Иран, острова Крит, Кипр; на последнем поднимается до 1000 м абсолютная высоте, установление границ естественного ареала невозможно, так как *Cupressus sempervirens* введен в культуру с древнейших времен в западном Азии, южной Европе и северной Африке; культивируется в садах Афганистана, северно-восточной Индии, во всем Средиземноморском бассейне. В теплых местах южной Германии иногда повреждается морозом. На Южном берегу Крыма введен древне - греческими поселенцами, вновь интродуцирован здесь с 1778 г. в Алушке и с 1813 г. в Никитском ботаническом саду и отсюда распространился по Южному берегу Крыма от

Феодосии до Севастополя и до 300 м над уровнем моря, придав всему пространству специфический южный ландшафт; в Бахчисарае страдает от мороза. Крупнейшую роль особенно *Cupressus sempervirens* f. *pyramidalis* играет в ландшафте Черноморского побережья Кавказа. Дерево 25-30 м высоты со стволом 50-60 см в диаметре, с относительно тонкими, сближенными ветвями, образующими узкоцилиндрическую или пирамидальную крону. Ствол прямой, малосбежистый, покрыт тонкой, серовато - коричневой с поверхности и красновато - коричневой внутри, продольно - поверхностно растрескивающейся корой. Побеги округло - четырехгранные, направленные во все стороны. Листья мелкие, вытянуто ромбические, едва зубчатые по краю, с овальной, смоляной железкой на спинке, тёмно-зелёные, тусклые или несколько блестящие, на большом своем протяжении приросшие к побегам и плотно прижатые к нему шишке достигающие большей величины в первом году, еще до созревания открываются обычно на второй и третий год, сперва зеленые, затем блестяще-коричневые и более сереющие, округлые или несколько удлинённые, 2—3 см в диаметре, из 8—12 чешуй; последние неправильно 5—6-угольные, плотно прилегающие друг к другу, снаружи несколько вздутые или плоские, с коротким и притупленным острием в центре. Семена по 8—20 за каждой чешуей, 5—7 мм длины, красновато-бурые, блестящие, с узким крылом. Плодоношение наступает с 4 (3—6) лет и далее обильное ежегодно, полно зернистых семян около 37%. Всхожесть сохраняется до 10 лет.

Древесина кипариса употребляется для мебели и для мелких резных и токарных поделок; она является стойкой против насекомых. Из молодых ветвей можно добывать эфирное масло. Древесина заболонная, желтовато-розовая, с характерным резким запахом. Годичные слои хорошо видны на всех разрезах. На поперечном разрезе годичные слои волнистые. Поздняя древесина буровато - желтая, сравнительно узкая, ранняя древесина светлее и шире поздней. Сердцевинные лучи простым глазом незаметны ни на одном из разрезов. Смоляных ходов нет. Древесина мягкая и легкая, по механическим свойствам приближающая к сосне.

В Узбекистане первый раз завезён в Денауский дендрарий в 1946 году. Широко распространён по всей Сурхандарьинской и Кашкадарьинской областях. Характеризуется чрезвычайно быстрым ростом. В 50-летнем возрасте достигает в среднем 31,3 м, высоты и 43,2 см в диаметре.

Особенно быстро растёт в молодом возрасте. В 9-летнем возрасте достигает 7,5 м высоты. Текущий прирост после 5 лет превышает 1,2 м. Первые шишки появились на деревьях в 5-летнем возрасте. В условиях на юге Узбекистана регулярно образует семена хотя не обильно (2-4 балла).

Cupressus sempervirens в 1-2 летнем возрасте растут медленно. Ускорение роста начинается с 3-4 летнего возраста, а цветение наступает в 5 летнем возрасте.



Рис.1. Кипарис вечнозелёный растущий в Денауском дендрарии

В молодом возрасте кипарис переносит длительное время довольно сильное затенение, но прекрасно растёт и на полном свете. Засухоустойчив. Корневая система мощная, на рыхлых почвах стержневая. Долговечность 2000 лет.



Рис. 2. Кипарис вечнозелёный произрастающий в естественном виде

Возраст первого плодоношения интродуцентов в Республике

Вид	Жизненная форма	В Республике		Источник
		Первое цветение	Первое плодоношение	
<i>Cupressus arizonica</i>	Д	5	13	Т.И.Славкина, 1968 г.
<i>Cupressus sempervirens</i>	Д	5	6	Л.Х.Ёзиев, 2001 г.
<i>Chamaecyparis lawsoniana</i>	Д	8	8	Т.И.Славкина, 1968 г.

Размножают посевом, обычно прямо в гряды, которые с 2-3 лет идут в школу и в 3-4 летнем возрасте в посадку на место. Черенкование 5-6 см черенками в песок; укоренение следует через 30 дней. Возможно размножение прививкой, преимущественно садовых форм. *C. sempervirens*, особенно его пирамидальная форма, широко применяется и заслуживает еще большего распространения в аллеиных посадках, обсадках дорог, в группах, солитерных посадках; из него удаются прекраснейшие монументальные живые изгороди, стены и защитные полосы. Кипарис хорошо выносит и подстрижку; так как он выносит густое стояние, то при своем быстром росте перспективен и для лесного хозяйства, а также благоустройства города на юге и Центральной части Узбекистана.

Использованные источники:

1. Озеленительный ассортимент и уход за городскими насаждениями Узбекистана/ Л.А.Абдурахманов, Т.И. Славкина. –Т., 1980.
2. Опыт интродукции древесных растений в южный Узбекистан/ Л.Х. Ёзиев.- Т., 2001.
3. Культура озеленения/ В.П. Печеницын, А.А.Азамов.– Т., 2005
4. «Размножение и выращивание декоративных древесных пород». В. И. Климович - М.1987.
5. Декоративное садоводство / Т.И. Славкина, О.И. Подольская.– Т., 1987.

*Асронов Э.К.
старший преподаватель
Солиева М.Б.
старший преподаватель*

Андижанский институт сельского хозяйства и агротехнологий

ВЛИЯНИЕ ИЗМЕНЕНИЯ ТЕМПЕРАТУРЫ НА ПРОДУКТИВНОСТЬ И КАЧЕСТВО КОКОНОВ ВО ВРЕМЯ КОРМЛЕНИЯ ТУТОВОГО ШЕЛКОПРЯДА

Аннотация: Все жизненно важные процессы шелкопряда - рост, скорость развития, продолжительность жизни, плодовитость, продуктивность и т. д. - проявляются при нормальных температурах. Средняя температура тутового шелкопряда + 25-26⁰С. Эксперименты показали изменения урожайности и прорастания коконов в результате высоких или низких температур во время кормления гусениц и обертывания коконов, что отрицательно влияет на физиологию определенных органов в теле личинок, в том числе на активность желез внутренней секреции шелкопряда, вырабатывающего шёлковое волокно.

Ключевые слова: тутовый шелкопряд, пайкилотерм, температура, влажность, шёлкоотделительные железы, биологические показатели, урожай коконов, продуктивность, технологические показатели.

*Aronov E. K.
senior lecturer
Solieva M. B.
Senior lecturer*

Andijan Institute of Agriculture and Agricultural Technologies

INFLUENCE OF TEMPERATURE CHANGE ON PRODUCTIVITY AND QUALITY OF COCOONS DURING THE FEEDING OF WHITE SILKWINE

Abstract: All vital processes of the silkworm - growth, development rate, life span, fertility, productivity, etc. - are manifested at normal temperatures. The average temperature of the silkworm is + 25-26⁰C. Experiments have shown changes in the yield and germination of cocoons as a result of high or low temperatures during feeding of caterpillars and wrapping of cocoons, which negatively affects the physiology of certain organs in the larva's body, including the activity of the endocrine glands of the silkworm, which produces silk fiber.

Key words: silkworm, pikilotherm, temperature, humidity, silk glands, biological indicators, cocoon yield, productivity, technological indicators.

В течение жизненного цикла живых организмов для хорошего обмена веществ необходимо определенное количество тепла. Температура играет большую роль, особенно для насекомых, в том числе тутового шелкопряда. Потому что насекомые хладнокровные - *пайкилотерм*, то есть организм, у которого нет постоянной температуры тела. Поддержание относительной влажности воздуха при температуре играет важную роль в жизни тутового шелкопряда. Когда в червоводне много влаги, испарение затрудняется, температура тела червя повышается. И наоборот, при понижении влажности кормовой лист быстро сохнет, его поедаемость снижается, черви обвиваются вокруг небольшого кокона, и качество кокона ухудшается.[4]

Когда температура в червоводне умеренная, черви хорошо питаются, быстро растут и продуктивны. Температура ниже или выше нормы может привести к нарушению физиологических и биохимических процессов в организме червя, что, без хорошего пищеварения в свою очередь, может привести к заболеванию.

Каждый жизненный процесс тутового шелкопряда - рост, скорость развития, долговечность, плодовитость, продуктивность и т. д. - проявляется при нормальных температурах. Средняя температура тутового шелкопряда + 25-26⁰С. Когда температура у личинок ниже или выше этой нормы, клеточный состав тела личинок приводит в первую очередь к изменениям протоплазмы. Это может привести к повреждению белков в клетке и, как следствие, к негативным изменениям жизненно важных процессов в организме.[5]

Изменения температуры во время кормления гусениц шелкопряда и обертывания коконов отрицательно сказываются на физиологии определенных органов в теле личинки, включая активность желез внутренней секреции, вырабатывающего шелк, а также на урожайность и разнообразия видов коконов. Результаты этого исследования представлены в таблице №1 ниже.

Данные в таблице показывают, что железы тутового шелкопряда, которых кормили при температурах ниже или выше нормы, были немного меньше, и коконы, в которые они были завернуты, также были меньше. В результате урожай с одного коробочка таких гусениц (в среднем 62-64 кг.) был на 9-10 кг. меньше, чем у гусениц, выращенных в умеренных условиях (в среднем 72-73 кг).

То, как шелкопряды развиваются по возрасту, и количество шелка, которое они синтезируют, накапливая энергетические ресурсы во взрослом возрасте, проявляются во время обертывания кокона. Следовательно, количество коконов, обернутых гусеницами, которых кормили при низких или высоких температурах, было низким, и качество тоже было несколько ниже. [6]

Данные показывают, что при кормлении тутовых шелкопрядов при температурах ниже нормальной (+ 20-21⁰С) или высоких (+ 28-29⁰С)

производительность коконов составила 80-86%, что на 6–12% ниже производительности шелкопряда, кормленного при умеренной температуре (91-92%), а также наблюдается пропорциональное уменьшение количества сортовых коконов.

Влияние температуры и активности шелковых желез на урожай и качество коконов

Таблица №1

Варианты	Температура при кормлении °С	Объём шелковых желез, см ³	Урожай коконов, полученный из 1-коробки, кг.	Pd	Количество сортовых коконов, %.	Несортные коконы, %	Pd
порода Ипакчи-1							
B ₁	+25-26	1,47	72,0±0,57	-	91,0±0,58	9	-
B ₂	+20-21	1,30	66,0±0,48	0,990	85,0±0,56	15	0,994
B ₃	+28-29	1,20	62,0±0,46	0,998	80,0±0,55	20	0,996
порода Ипакчи-2							
B ₁	+25-26	1,52	73,0±0,59	-	92,0±0,59	8	-
B ₂	+20-21	1,35	68,0±0,50	0,998	86,0±0,57	14	0,995
B ₃	+28-29	1,25	64,0±0,47	0,992	81,0±0,55	19	0,997

В зависимости от температуры наблюдается обертывание кокона тутового шелкопряда, например при температуре + 20-21⁰С заворачивание волокна тутового шелкопряда длиной 5 мм происходит за 4,5 секунды, при температуре + 25-26⁰С за 3,4 секунды, при температуре + 28-29⁰С за 1,7 секунды. Поэтому в зависимости от температуры период окутывания кокона также варьируется, например, 5 дней при + 20-21⁰С, 3 дня при + 25-26⁰С, 2-2,5 дня при + 28-29⁰С. Все это влияет на урожайность кокона и его сортовые характеристики.

В результате, когда шелкопряд кормят при температуре ниже или выше нормы, метаболизм и физиологические процессы в организме нарушаются. В результате водный баланс организма, дыхание,

переваривание и усвоение питательных веществ, активность шёлкоотделительные желез замедляется, создавая условия для болезнетворных микроорганизмов, в результате чего, без хорошего развития уменьшается количество и качество коконов.

Использованные источники:

- [1]. Ахмедов Н, Муродов С – Основы шелководства, Ташкент, 1998г.
- [2]. Ахмедов Н, Муродов С- Экология и агротехника выращивания тутового шелкопряда, Ташкент, 2004
- [3]. Беккамов Ч.И., Данияров У.Т., Абдикаюмова Н.К., Ражабов Н.О. Шелководство и туководство. Учебник, 2017., 232 стр.
- [4]. Асронов Э.К., Солиева М.В. The importance of feeding silkworms under polyethylene. Журнал ACADEMICIA Vol. 10, Issue 10, October 2020. page no-1169-1174.
- [5]. Асронов Э.К., Зайробиддинов М. Размножение тутовника на открытой местности древесными черенками. Биоразнообразие и рациональное использование природных ресурсов. Материалы II Всероссийской научно-практической конференции с международным участием... 22-24, 2014 (Махачкала).
- [6]. T.S.Xudoyberdiev. B.R.Boltaboev. B.A.Razzakov. M.Sh.Kholdarov. "To The Fertilizer Knife Determination Of Resistance". //Asian Journal of Multidimensional Research (AJMR) // Vol 9, Issue 8, August, 2020. <https://www.indianjournals.com/ijor.aspx?target=ijor:ajmr&volume=9&issue=8&article=011>

УДК 66.023

*Ахунбаев А.А., кандидат технических наук
доцент кафедры «Технологические машины и оборудования»
Ферганский политехнический институт,
Республика Узбекистан, г. Фергана
Ражабова Н.Р.*

*ассистент кафедры «Технологические машины и оборудования»
Ферганский политехнический институт
Республика Узбекистан, г. Фергана
Вохидова Н.Х.*

*ассистент кафедры «Технологические машины и оборудования»
Ферганский политехнический институт
Республика Узбекистан, г. Фергана*

ИССЛЕДОВАНИЕ ГИДРОДИНАМИКИ РОТОРНОЙ СУШИЛКИ С БЫСТРОВРАЩАЮЩИМСЯ РОТОРОМ

Аннотация: В работе изучена гидродинамика роторной сушилки с быстровращающимся ротором при сушке тонкодисперсных материалов. Экспериментальным путём определены кривые отклика системы на возмущения и определены гидродинамические параметры роторной сушилки. Дано уравнение для расчёта роторной сушилки. Показана возможность организации непрерывного режима работы аппарата.

Ключевые слова: гидродинамический режим, тонкодисперсные материалы, возмущения, расчётные параметры, непрерывный режим.

*Axunbayev A.A., Candidate of Technical Sciences
Associate Professor of the Department of Technological Machines and
Equipment*

*Fergana Polytechnic Institute
Republic of Uzbekistan, Fergana city
Rajabova N.R.*

*Assistant Department of Technological Machines and Equipment
Fergana Polytechnic Institute
Uzbekistan*

*Vokhidova N.X.
Assistant Department of Technological Machines and Equipment
Fergana Polytechnic Institute
Uzbekistan*

STUDY HYDRODYNAMICS OF FAST-SPINNING ROTOR DRIER

Annotation: The paper studies the hydrodynamics of a rotary dryer with a fast-rotating rotor when drying fine materials. The curves of the system's response to disturbances were determined experimentally and the hydrodynamic parameters of the rotary dryer were determined. An equation for calculating a rotary dryer is given. The possibility of organizing a continuous mode of operation of the apparatus is shown.

Keywords: hydrodynamic regime, finely dispersed materials, disturbances, design parameters, continuous regime.

Применение роторной сушилки с быстровращающимся ротором для сушки тонкодисперсных материалов является перспективным по сравнению с другими типами сушилок. Это связано с тем, что при применении конвективных сушилок вследствие неэффективности пылеулавливающей аппаратуры происходит унос частиц части материала, что приводит к его потере и загрязнению окружающей среды [1].

Одним из методов интенсификации тепло- и массообмена в контактных аппаратах является увеличение скорости движения сушеного материала относительно греющей поверхности, которое может быть реализовано в контактной роторной сушилке с быстровращающимся ротором, что позволяет увеличить эффективный коэффициент теплоотдачи в 2-4 раза [2]. Вопросы тепло- и массообмена для периодических сушилок данного типа хорошо изучены многими исследователями [3].

При переходе на непрерывный режим работы аппарата появляются некоторые новые вопросы гидродинамики материала, такие как:

- вопросы устойчивости образующегося слоя дисперсного материала, при непрерывном режиме работы аппарата,
- продольное перемешивание дисперсного материала,
- время пребывания материала в аппарате или удерживающая способность аппарата,
- вопросы организации загрузки и выгрузки материала.

С целью выяснения устойчивого режима работы и определения параметров гидродинамической модели движения дисперсного материала были проведены соответствующие экспериментальные исследования.

Для определения экспериментальным путем среднего времени пребывания дисперсного материала в аппарате и коэффициента продольного перемешивания был применен метод внесения возмущения в непрерывный поток материала в определенном сечении потока (на входе в барабан) и фиксирования вызванных этим возмущением последствий (отклика системы) в другом сечении (на выходе из аппарата). При этом возмущающий сигнал носил импульсный характер. По функциям отклика на сигнал (С - кривым) определены гидродинамические параметры системы. Опыты проводились на диоксиде кремния со средним размером частиц 40

мкм. В качестве трассера использовалась кремневая кислота $\text{SiO}_2 \cdot \text{H}_2\text{O}$ того же дисперсного состава, что и диоксид кремния.

Кривые отклика (С - кривые) системы на импульсный ввод трассера определялась следующим образом: в определенный момент времени вместо непрерывно подаваемого в аппарат потока диоксида кремния импульсно подавалось фиксированное количество трассера. Продолжительность импульса подачи трассирующего материала не превышала двух секунд. На выходе из аппарата через определенные промежутки времени отбирались пробы дисперсного материала и весовым методом, путем термического обезвоживания отобранных проб при $t = 300^\circ\text{C}$ определялась кривая отклика аппарата- это концентрации H_2O в материале.

При проведении опытов изменялись следующие параметры:

расход материала в пределах $(1,2-4) \cdot 10^{-3}$ кг/с,
угловая скорость вращения ротора 20-100 рад/с,
высота выгрузного порога 0 – 35 мм.

Полученные экспериментальные кривые отклика по характеру совпадают с аналитической зависимостью, являющейся решением квазидиффузионной модели перемешивания материала [4].

Использование трассера для определения коэффициента продольного перемешивания в рамках двухпараметрической одномерной квазидиффузионной модели основана на уравнении

$$\frac{\partial c}{\partial \tau} + W \frac{\partial c}{\partial x} = D_T \frac{\partial^2 c}{\partial x^2} \quad (1)$$

Где c – концентрация трассера, кг/кг;

$W = L / \tau$ – средняя скорость движения материала в слое, м/с;

x – текущая координата, направленная вдоль оси барабана, м;

D_T – коэффициент продольного квазидиффузионного перемешивания материала, $\text{м}^2/\text{с}$.

В качестве граничных условий – к уравнению (1) используются традиционные условия Данквертса:

$$WC_0 = WC \Big|_{x=0} - D_T \frac{\partial c}{\partial x} \Big|_{x=0}; \quad (2)$$

$$\frac{\partial c}{\partial \tau} \Big|_{\tau=0} = 0; \quad (3)$$

$$\frac{\partial c}{\partial x} \Big|_{x=L} = 0 \quad (4)$$

При обработке экспериментальных кривых распределения материала по времени его пребывания в соответствии с решением диффузионного уравнения (1) число Пекле определялось таким образом, чтобы среднеквадратическое расхождение опытных и теоретических кривых было минимальным.

При обработке экспериментальных данных в опытах с меченым материалом среднее время пребывания определялось по уравнению

$$\tau = \sum_{i=1}^n \pi_i C_i / \sum_{i=1}^n C_i \quad (5)$$

Результаты обработки экспериментальных данных показали, что для исследованного аппарата при угловой скорости ротора менее 30 рад/сек продольное перемешивание незначительно. При этом режим движения материала в аппарате является устойчивым. Физически это соответствует картине, когда материал залегаёт на дне аппарата и только ворошится лопатками медленно вращающегося ротора. При увеличении угловой скорости выше 30 рад/с происходит увлечение коэффициента продольного перемешивания. При этом слой материала под действием центробежной силы распределяется по всей внутренней поверхности барабана.

При наличии порога на выгрузке материала дальнейшее увеличение угловой скорости ведёт к возрастанию коэффициента продольного перемешивания, так как увеличивается импульс силы, передаваемой лопаткой элементу слоя. Это увлечение происходит несколько в меньшей степени, чем линейно, поскольку действует фактор уплотнения слоя, препятствующий перемешиванию. Одновременно возрастает величина среднего времени пребывания, так как уплотнение слоя приводит к увеличению массы материала в аппарате.

При уменьшении уровня порога на выгрузке до 0 характер зависимости τ принципиально изменяется. Время пребывания материала в слое в 2-3 раза меньше, чем при наличии порога и это естественно, связано с более свободной выгрузкой материала. Это приводит к уменьшению плотности слоя частиц, сформированного в зазоре. При этом импульс, передаваемый лопатками элементу слоя, приводит к слабому рассеянию частиц в продольном направлении, что и отражает эксперимент. Дальнейшее увеличение высоты порога более 30 мм приводит к нарушению устойчивости выгрузки материала из аппарата, видимо, вследствие больших центробежных сил и увеличения массы слоя.

Данные экспериментов дают возможность утверждать, что при наличии на выгрузке из аппарата порога большего, чем размер зазора между лопатками ротора и стенкой барабана, в аппарате формируется устойчивый движущийся слой материала. Скорость продольного перемешивания в таком слое зависит, в основном, от числа оборотов ротора, незначительно увеличивается с увеличением производительности аппарата V и практически не зависит от массы слоя. При этом слой может рассматриваться как сжимаемая среда с практически постоянными гидромеханическими свойствами. При определенной высоте порога происходит резкое уменьшение скорости перемешивания и нарушение устойчивости движения материала в аппарате.

Экспериментально установлено, что устойчивая работа аппарата в непрерывном режиме движения материала имеет место, если $K_3 < 1$, при этом механизм движения слоя тонкодисперсного материала является квазидиффузионным. Измерения показали, что распределение концентрации материала в продольном направлении является практически равномерным и изменяется не более чем на 10% на метр длины аппарата. При $K_3 \approx 1$ происходит уплотнение слоя и структурообразование материала в объеме зазора, что приводит к значительному снижению интенсивности квазидиффузионного перемешивания материала и к нарушению устойчивости работы аппарата.

Экспериментальные данные обрабатывались методом наименьших квадратов, что привело к следующим корреляционным зависимостям:

$$D_T = 2,2 \cdot 10^{-3} \left(\frac{h}{R} \right)^{0,84} \left(\frac{\omega}{\omega_{kp}} \right)^{0,86} (V)^{0,40}, \text{ м}^2 / \text{с} \quad (7)$$

$$\tau = 30 \left(\frac{h}{R} \right)^{0,36} \left(\frac{\omega}{\omega_{kp}} \right)^{0,43} (V)^{0,41}, \text{ с} \quad (8)$$

Зависимости (7) и (8) получены в следующих интервалах изменения параметров:

$$\omega = 40 - 100 \text{ рад/с};$$

$$V = (1,2 - 4,0) 10^{-3} \text{ кг/с};$$

$$h = 0 - 15 \text{ мм}.$$

Проведенные эксперименты показали возможность организации непрерывного режима работы аппарата. Полученные уравнения [7] и [8] позволяют определить гидродинамические параметры указанного режима, что необходимо при расчёте процесса сушки в данном аппарате.

Использованные источники:

1. Фролов В.Ф., Круковский О.Н., Ахунбаев А. А. Сушка высоковлажных тонкодисперсных материалов // Минский международный форум «Тепломассообмен в химико-технологических устройствах» Тез. докл. – Минск, 1992. – С. 83.
2. Schliinder E.V. Fortschritte in den wissenschaftlichen Grundlagen zur Auslegung von Kontaktroknern fiir grob – und feinriselfahiges Trocknungsgut // Chem. Ing. Tech. – 2003. – Т. 75. №. r 12. – s. 940 – 949.
3. Сомов А.М. Термобработка дисперсных материалов в барабанно-центробежной сушилке: Дис.... Канд. Техн. Наук / ЛТИ им. Ленсовета. – Л., 1980, - 190 с.
4. Кафаров В.В., Перов В.Л., Мешалкин В.П. Принципы математического моделирования химико-технологических систем. – М.: Химия, 1974. – 344 с.

*Базаров А.А.
старший преподаватель
Ферганский политехнический институт
Узбекистан, г. Фергана*

РТУТЬ В ПОДЗЕМНЫХ И ПОВЕРХНОСТНЫХ ВОДАХ БУХАРО-КАРШИНСКОЙ НЕФТЕГАЗОНОСНОЙ ОБЛАСТИ

Аннотация: В статье приводятся результаты анализа и сопоставления подземных вод отложений Бухаро-Каршинского артезианского бассейна нефтегазоносной области.

Ключевые слова: месторождение, геохимия ртути, подземные воды, бассейн, концентрация.

*Bazarov A. A.
senior lecturer
Ferghana Polytechnic Institute
Uzbekistan, Ferghana*

MERCURY IN UNDERGROUND AND LAND WATER OF THE PETROLEUM AND GAS REGIONS OF BUKHARO-KARSHI

Abstract: The article presents the results of analysis and comparison of groundwater deposits of the Bukhara-Karshi artesian basin and deposits of the oil and gas region.

Keywords: deposit, geochemistry of mercury, groundwater, basin, concentration.

Основные особенности геохимии ртути выявлены главным образом при изучении геологии, геохимии и гидрогеохимии рудных месторождений. В настоящее время накоплен большой материал о распределении этого элемента в различных природных объектах, обобщенный в работах А.А.Саукова, Н.А.Озеровой, Н.Х. Айдиньян, А.А. Оболенского, В.И.Смирнова, Д.С.Мукимовой, В.А.Кузнецова, Д.Уайта, В.П.Федорчука, В.З.Фурсова, И.Л.Ходаковского, Н.Д.Шикина, З.А.Яночкиной и многих других исследователей[2].

Анализы подземных вод производились в институте ГИДРОИНГЕО атомно-абсорбционным методом на спектрофотометре С-302 и сведены в каталог химических анализов поверхностных и подземных вод Бухаро-Каршинского артезианского бассейна опробованных на ртуть за 2005-2007 гг.[8].

Всего отобрано и проанализировано более 300 проб воды из них 30 проб отобрано колодцев, большинство из которых используются местным населением для питья и водопоя скота. Пробы подземных вод отобраны из четвертичных, неогеновых, палеогеновых, меловых, юрских (терригенных, подрифовых, рифовых, и надрифовых) отложений Бухаро-Каршинского артезианского бассейна.

В 80% отобранных пробах подземных и поверхностных вод отмечены значимые концентрации ртути. Максимальные концентрации ртути 13,4 мкг/л (скв.171^а), 12,5 мкг/л(скв.2), 10,08мкг/л(скв11); минимальные концентрации ртути 0,8 мкг/л к-ц Учмулла. Ниже в таблице № 1 приводится концентрация ртути в подземных водах Бухарской и Кашкадарьинской областей [8].

Результаты определения ртути в пробах подземных вод.

Таблица №1

№ пробы	Лабораторный номер	Номер скважины	глубина отбора, м	Концентрация ртути мкг/л
1	2640	47	350-370	6,95
2	3040	14	10	0,56
3	3041	10	6,3	0,2
4	3044	5	8,45	0,16
5	3046	1	0,6	0,28
6	3051	колодец Хайдар	20,4	0,38
7	3057	скв.Деволкак	21,1	0,38
8	3055	колодец 288	3,6	1,04
9	3054	озеро Дюкерь	2,5	0,21
10	3050	скв. Писта	6,7	0,16
11	3404	44	1,32	15,0
12	3402	РШ-70	4,5	6,1
13	3405	1114	45,1	3,3
14	3406	Т-500	3,5	15,0
15	3407	51	4,9	36,3
16	2634	35	0,5	5,8
17	2605	30	22	6,4
18	2604	к-ц Шоркудук	10	27,8
19	2602	к-ц Улан деке	63	7,8
20	2615	к-ц Гуур	28	4,2
21	2620	РШ-30	5	5,8
22	2635	53	35	20,9
23	2611	7 ^А	3,1	7,4
24	2603	коллектор Т-4	2,7	7,6
25	2612	к-ц Янгикурулак-2	18,5	7,8
26	3593	163	8,6	-
27	3587	142 ^В	10,1	-
28	2610	к-ц Шокирака	6-7	3,5

Результаты определения ртути в подземных водах Бухаро-Каршинского артезианского бассейна [8].

Таблица 2

номер пробы	номер скважины	Глубина отбора пробы(м)	Геологический возраст опробованного горизонта.	Концентрация Ртуты в мкг/л	Превышение ПДК, раз.(при ПДК =0,5мкг/л)
1	2	3	4	5	6
98	55	34-49	N ₂	не обнаруж.	-
102	31	469-502	P	2,8	5,6
77	3	40-45	N ₂	2,9	5,8
67	3	40-45	N ₂	не обнаруж.	-
54	Буровая Галакпая	40-45	N ₂	5,4	10,8
82	38	39-44	N ₂	не обнаруж.	-
97	2	40-45	N ₂	не обнаруж.	-
61	5	40-45	N ₂	30,0	60,0
75	Колодец Абдумажид	36,0	N ₂	0,41	ПДК
44	33	23,0	N ₂	не обнаруж.	-
72	11	350,0-360,0	N ₂	не обнаруж.	-
81	Колодец Полевой(откачка)	42,1	N ₂	12,1	24,2
78	Колодец Алачава	12,2	N ₂	2,5	4,3
66	2	23-28	N ₂	2,9	5,8
91	58	350-370	N ₂	10,2	20,4
69	10. -		N ₂	6,2	12,2
1	Сюзьма (самоизлив.скв-на)	34-39	N ₂	1,5	3,0
2	Сюзьма (самоизлив.скв-на)	34-39	N ₂	1,5	3,0
3	Учкыр (самоизлив.скв-на, стар. посёлок)	34-39	N ₂	2,7	5,4
Нефтегазоразведочные скважины					
12	Зап.Крук скв.7	2452-2446	J ₃ XV-P	не обнаруж.	
18	Сев. Сарыташ, скв.1	1521-1511	J ₁₊₂ XVIII	2,45	4,9
20	Сев. Сарыташ, скв.1	1499-1491	J ₁₊₂ XVIII	3,0	6,0
21	Сев. Сарыташ, скв.1	1336-1327	J ₃ XV	11,8	23,6
22	Сев. Сарыташ, скв.1	1111-1101	K ₂ пе-apt	4,2	8,4
23	Сев. Сарыташ, скв.	1053-1049	K ₂ пе-apt	10,5	21,0

24	Сев. Сарыташ, скв.1	1039-1032	K ₂ пе-арт	3,0	6,0
30	Сев. Сарыташ, скв.1	3189-3175	J ₃ XV-пр	не обнаруж.	-
5	Кокдумалак	3106-3102	J ₃ XV-пр	10	20
11	Кокдумалак	3084-3081	J ₃ XV-пр	10	20

Следует отметить, что максимальные концентрации ртути в водах соответствовать к зонам пересечения разломов и участкам повышенной тектонической активизации (район Денгизкульского поднятия, Газлийское поднятие).

Отмеченное выше подтверждается результатам лабораторных исследований по взаимодействию водных растворов ртути с нефтью. После 10-дневного термостатирования (60⁰ С) с попеременным встряхиванием водных растворов ртути с концентрацией 50 мкг/л с нефтью (соотношение вода-нефть равно 5:1) содержание ртути в воде снизилось до 5 мкг/л.

В водах газовых и газоконденсатных месторождений Бухара-Каршинской нефтегазоносной области ртуть обнаружена во всех проанализированных пробах воды. Среднее ее содержание является относительно высоким, а максимальные концентрации, достигающие 60мкг/л, приурочены к контурной зоне газовых залежей. Таким образом, здесь в противоположность нефтяным месторождениям проявляются водные ореолы ртути положительного знака, указывающие на переход ртути из залежи в подпирающие их подземные воды.

Факт переноса ртути с углеводородными газами может указывать на то, что основным источником ртути в газах и водах служат те же осадочные породы, в которых в результате катагенных процессов генерируются жидкие и газообразные углеводороды.[7].

Однако определенная часть ртути в водах имеет и ювенильную природу, например, Шаимском районе. Здесь вдоль осевой части Шаимского вала установлен разлом, к которому приурочены тепловая и газовая аномалии (подземные воды газируют углекислотой). На всем протяжении этого разлома в подземных водах обнаруживаются исключительно высокие концентрации ртути (100-180мкг/л) (В.М. Матусевич, 1974).[1].

Использованные источники:

1. Хасанов А.С. Изучение закономерностей распространения ртутных аномалий в Бухаро - Каршинской нефтегазоносной области". Отчет по теме 037 за 1988-1990 гг. Ташкент .1990 гг.
2. Озерова Н.А. Ртуть и эндогенное рудообразование «Наука» Москва 1986.
3. Головин А.А.Гусев Г.С.и др. Ртутметрические методы при геологических исследованиях Москва. Геокарт-Геос. 2006.

4. Бакиев С.А. “Изучение закономерностей распространение ртутных аномалий Мезазойская отложение в Бухаро - Каршинской артезианская бассейна”. Отчет по темае 302 за 2005-2007 гг. Ташкент.2007 гг.

*Базилян М.А.
студент магистратуры
Уральский институт управления - филиал
ФГБОУ ВО «Российская академия народного хозяйства и
государственной службы при президенте Российской Федерации»
Российская Федерация, г. Екатеринбург*

АКТУАЛЬНЫЕ ВОПРОСЫ ЭКОНОМИКИ ПРИ ГРАДОСТРОИТЕЛЬСТВЕ

Аннотация: В статье рассмотрены вопросы, касающиеся современного подхода к градостроительству и проблемы, которые встречаются в этой сфере. Экономический аспект данных вопросов также был изучен в данной работе.

Ключевые слова: ландшафтный дизайн, территориальное планирование, градостроительное зонирование, институт страхования ответственности, система саморегулирования.

*Bazikyan M.A.
master's student
Ural Institute of management-branch of Ranepa
Russia, Yekaterinburg*

ACTUAL ISSUES OF ECONOMY IN URBAN PLANNING

Annotation: The article deals with issues related to the modern approach to urban planning and problems that occur in this area. The economic aspect of these issues has also been studied in this paper.

Keywords: landscape design, territorial planning, urban planning, liability insurance Institute, self-regulation system.

Экономика градостроительства — важнейшая составная часть градостроительной деятельности. В наиболее широкой интерпретации предметом ее изучения являются экономические аспекты любых процессов и проблем, связанных с развитием городских поселений, включая причины появления и развития городов, стабилизации городского роста, появления кризисных городов, экономические проблемы, возникающие в процессе развития городских поселений.

Современные проблемы градостроительства в РФ связаны с двуединой задачей — сохранение лучших традиций отечественного градостроительства и поиск новых форм управления сферой

градостроительства в условиях возрастающей глобализации при возбуждении процессов самоорганизации активной части населения.

Инженерно-экономические основы планировки городов и районов были определены доктором эконом, наук В. Г. Давидовичем в книге «Планировка городов и районов. Инженерно-экономические основы» (М.: Стройиздат, 1964). Существенный вклад в развитие отечественной экономики градостроительства внесли исследования экономического подразделения ЦНИИП градостроительства, в составе которого работали известные экономисты-градостроители: Я. П. Левченко (экономика использования городских территорий), £ Я. Вольфензон (нормативы развития социально-культурной подсистемы города), Г. А. Каплан (экономические основы районной планировки, экономическая база городских поселений), М. С. Вайнберг (выбор эффективной этажности жилой застройки), А. В. Кочетков (эффективность градостроительных решений). Более 25 лет проработала в отделе А. К. Иванова, которая плодотворно занималась проблемами эффективной этажности, использования городских территорий.

Отдельная градостроительная проблема для российских городов – управление сферой городского и ландшафтного дизайна для поднятия уровня благоустройства и улучшения облика российских городов и поселений.

Одна из главных проблем градостроительной деятельности заключается в отсутствии качественной документации территориального планирования и градостроительного зонирования. Сегодня практически на 100% утверждены схемы территориального планирования субъектов Российской Федерации, свыше 90% схем территориального планирования муниципальных районов и генеральных планов городских округов и городских поселений утверждены или находятся на стадии согласования и утверждения. Однако качество исполнения этих документов крайне низкое. А ведь именно на основе документов территориального планирования, правил землепользования и застройки и документации по планировке территории осуществляется строительство. Отсутствие ясного понимания, какой именно объект можно строить на конкретном земельном участке, существенным образом тормозит развитие строительной отрасли.

Важной проблемой является также развитие института страхования ответственности в строительстве, так как это действенный способ обеспечения безопасности. Страховщики обладают своим собственным интересом, чтобы не допустить возникновения страховых случаев. Сегодня, когда не решена проблема строительных фирм-однодневок и "коммерческих СРО", когда отсутствуют четкие критерии понятия "страхового случая в строительстве", остаются актуальными вопросы применения франшизы, институт страхования ответственности не работает должным образом и лишь в некоторых случаях смягчает уже случившиеся

негативные последствия. Введение негосударственного строительного надзора также требует дополнительного обсуждения с учетом мнения профессионального сообщества, соблюдения баланса как частных, так и общественных интересов.

Требует совершенствования и система саморегулирования, пришедшая на смену лицензированию. Главная цель саморегулирования – это создание объединения ответственных участников строительного процесса.

Проблематика изучения инфраструктуры рынка городских земель остается одной из ведущих в отделе и в настоящее время. За последние пять лет было выполнено крупное исследование по анализу рынка земель и определению рыночной стоимости земли для различных категорий землепользователей в 11 городах Самарской обл. Общепринятые в странах с рыночной экономикой методы оценки рыночной стоимости земли были адаптированы к условиям России. В результате определены показатели нормативной стоимости земли, утвержденные Самарской областной думой. Аналогичная работа выполнена по г. Краснослободску Волгоградской обл. По заказу Краснодаргражданпроекта в рамках разработки генерального плана г. Геленджика проведен анализ земельного рынка, с его учетом разработаны экономические механизмы реализации проектных предложений. По заказу администрации Самарской обл. выполнено исследование, результатом которого явилась разработка экономических механизмов регулирования городского землепользования.

Новая социально-экономическая ситуация диктует и новые направления исследований в этой сфере. Среди них, например, оценка инвестиционной привлекательности городских территорий и определение путей ее повышения; анализ экономических и градостроительных последствий проведения земельной реформы в городах и наиболее эффективные направления устранения негативных явлений, оценка состояния инфраструктуры рынка городских земель и разработка рекомендаций по его совершенствованию.

Любой рынок, особенно земельный, в целях его цивилизованного развития нуждается в государственном регулировании, один из основных элементов которого — градостроительное регулирование. Вместе с тем основная часть городских поселений не имеет обновленной градостроительной документации, но даже там, где она выполняется, используются устаревшие методы и принципы. Попытка заменить отсутствие генеральных планов городов разработкой экспресс-методом нормативно-правового зонирования городских территорий представляется малоэффективной.

Использованные источники:

1. Ершов М. Актуальные проблемы рынка недвижимости в России/ М. Ершов - М.: ЮНИТИ. - 115 с.

2. Балабанов И.Т. Экономика недвижимости / И.Т. Балабанов - Спб.: Питер, 2002. - 208 с.
3. Бойко И.П. Основы бизнеса на рынке недвижимости / И.П. Бойко - М.: Экономика, 2002. - 183 с.
4. Федеральная служба государственной статистики [Электронный ресурс]- Режим доступа: <http://www.gks.ru/>.

*Баязитова Р.Н.
студент
ФГБОУ ВО «Башкирский государственный университет»
г. Уфа*

РАЗВИТИЕ НЕФТЕГАЗОВОГО СЕКТОРА РЕСПУБЛИКИ БАШКОРТОСТАН

Аннотация. Одной из основных стратегических целей государства является повышение качества и уровня жизни населения. Развитие экономики региона зависит от деятельности нефтегазового комплекса. В статье представлен стратегическое развитие нефтедобычи и нефтепереработки Республики Башкортостан.

Ключевые слова: нефтедобыча и нефтепереработка Республики Башкортостан, социально-экономическое развитие региона.

*Bayazitova R.N.
student
FSBEI of HE «Bashkir State University»
Ufa*

DEVELOPMENT OF THE OIL AND GAS SECTOR OF THE REPUBLIC OF BASHKORTOSTAN

Annotation. One of the main strategic goals of the state is to improve the quality and standard of living of the population. The development of the regional economy depends on the activities of the oil and gas complex. The article presents the strategic development of oil production and oil refining in the Republic of Bashkortostan.

Key words: oil production and refining of the Republic of Bashkortostan, socio-economic development of the region.

Основу экономического развития Республики Башкортостан (РБ) составляют нефтедобыча, нефтепереработка и нефтехимия. В валовом региональном продукте республики на эти подотрасли приходится значительный удельный вес.

Крупнейшей нефтедобывающей и нефтеперерабатывающей компанией в Республике Башкортостан является ПАО «АНК «Башнефть», объединяющая такие дочерние предприятия как⁵⁷ ООО «Башнефть-

⁵⁷ Годовые отчеты компании «Башнефть» за 2014, 2015, 2016, 2017, 2018, 2019 годы // Официальный сайт ПАО АНК Башнефть. – URL: <http://www.bashneft.ru/disclosure/annual/> (дата обращения 11.11.2020 г.)

Добыча», ООО «Башнефть-Полюс», ООО «ВОСТОК-НАО», «Башнефть-Уфанефтехим», филиал «Башнефть-УНПЗ», филиал «Башнефть-Новойл», ПАО «Уфаоргсинтез», ООО «Башнефть-Розница», ТОО «Башнефть-Азия» и др.

Безусловно, развитие нефтяного комплекса будет способствовать на развитие экономики региона в целом. Также, для более интенсивного развития необходимы стратегии развития нефтедобычи и нефтепереработки Республики Башкортостан на долгосрочную перспективу. Стратегия развития НПЗ Республики Башкортостан предполагает углубление глубины нефтепереработки, а также модернизацию производства, что будет способствовать к росту объемов проектирования, а также к росту спроса на услуги организаций. Кроме этого, в связи с дефицитом сырья, а также с целью увеличения добавленной стоимости за счет углубления нефтепереработки необходимо строительство новых мощностей в нефтяной отрасли, что, в свою очередь, будет способствовать к росту спроса на услуги НИПИ.

Рост спроса на нефтепродукты в дальнейшем будет стимулировать нефтяную компанию ПАО АНК «Башнефть» к соответствующему изменению ассортимента продукции, а также способствовать строительству гидрокрекинговых мощностей не только в Республики Башкортостан, но и в России. Для того, чтобы увеличить долю высококачественных нефтепродуктов в экспортируемой товарной продукции необходимо реализовать модернизацию действующих нефтеперерабатывающих заводов и дать возможность малым предприятиям заняться повторной добычей остатков сырья.

Ключевыми направлениями развития видов деятельности в области нефтепереработки являются: повышение глубины переработки нефти; необходимость модернизации и строительства новых мощностей по переработке; повышение требований к качеству выпускаемой продукции. С учетом проанализированных направлений развития компании ПАО АНК «Башнефть» позволили выявить следующие основные направления деятельности: технологии нефтепереработки; разработка собственных катализаторов; разработка новых продуктов нефтепереработки; переработка тяжелых нефтяных остатков. Для реализации данных направлений необходимо: развитие научно-технических разработок, которые будут способствовать углублению переработки нефти, а также создание новых технологий по каталитическому реформированию бензинов, гидроочистке топлив для реактивных двигателей и дизельных топлив, изомеризации и др.

Разработка целей и стратегии в области развития объектов нефтепереработки в дальнейшем необходимо достичь следующие три главные стратегические цели:

1) достижение нового уровня конкурентоспособности производственной базы, при котором отечественные предприятия имели бы конкурентные преимущества как на внутреннем, так и на внешнем рынках, благодаря созданию новых эффективных мощностей;

2) решение проблемы возрастающего избытка легкого углеводородного сырья путем переработки на нефтяных мощностях. Достижение данной цели означает рациональное использование имеющегося сырья и значительной части его новых объемов на нужды нефти с учетом экономической эффективности.

В связи с поставленными выше целями и существующими вызовами стратегическими приоритетами деятельности отрасли в области проектирования объектов нефтедобычи и нефтепереработки являются:

1) разработка масштабной программы модернизации нефтеперерабатывающих предприятий;

2) достижение технологического лидерства в области нефтедобычи и нефтепереработки;

3) обеспечение качества товарной продукции в соответствии с техническим регламентом, что позволит защитить маржу каналов сбыта на внутреннем рынке, обеспечить достаточный объем продуктов для каналов сбыта на внутреннем рынке;

4) развиваться до уровня лучших проектных институтов, в том числе за счет повышения уровня квалификации исследовательского и инженерного потенциала. Безусловным приоритетом при реализации стратегии в области нефтедобычи и нефтепереработки является выполнение обязательств нефтяных компаний.

Таким образом, для того чтобы увеличить темпы роста не только компании ПАО АНК «Башнефть», но и экономики Республики Башкортостан в целом необходимы не только планирование, но и стратегические цели и задачи. Важной и главной целью нефтяного комплекса, в первую очередь, является спрос на такой уникальный продукт как нефть, а также нефтепродукты. Как известно, спрос и предложение формируют значительную часть ВРП, пополняют бюджет и т.д. Именно поэтому необходимо улучшение нефтедобычи и нефтепереработки, для более глубокой и качественной переработки нефти, для дальнейшего распределения продукта на рынке.

Использованные источники:

1. Янгиров А.В. Воспроизводственный потенциал в системе управления региональной экономикой: диссертация на соискание ученой степени доктора экономических наук: 08.00.05 [Место защиты: Самарский государственный экономический университет]. – Уфа, 2008. – 398 с.

2. Годовые отчеты компании «Башнефть» за 2014, 2015, 2016, 2017, 2018, 2019 годы // Официальный сайт ПАО АНК Башнефть. – URL: <http://www.bashneft.ru/disclosure/annual/> (дата обращения 11.11.2020 г.)

3. Токтамышева Ю.С., Юсупов К.Н., Ахунов Р.Р. Рейтинговая оценка инновационного развития регионов // European Social Science Journal. 2013. № 8-2 (35). С. 423-431.
4. Янгиров А.В., Юсупов К.Н., Ахунов Р.Р., Уразаев Р.А., Рафиков Р.И., Якупова С.В. Проблемы развития регионов приволжского федерального округа: государственная собственность, диспропорции, накопление капитала: монография / ответственный редактор: А. В. Янгиров. Уфа, 2013.
5. Регионы России. Социально-экономические показатели. 2018: Стат. сб. / Росстат. – М., 2018. – 1326 с.

*Бичурина И.Р.
ФГБОУ ВО «Саратовская государственная
юридическая академия»
Россия, Саратов*

ПРОБЛЕМА ПАССИВНОЙ ЗАЩИТЫ В УГОЛОВНОМ ПРОЦЕССЕ

Аннотация: В статье рассматривается нарушение одного из конституционных прав – право подозреваемого (обвиняемого) на защиту. Нарушения могут проявляться и в оказании пассивной защиты адвокатами. В исследовании предложены пути решения поставленной проблеме.

Ключевые слова: защитник, адвокат, защита, подозреваемый, обвиняемый, конституционные права, пассивная защита.

*Bichurina I.R.
«Saratov State
Law Academy
Russia, Saratov»*

THE PROBLEM OF PASSIVE DEFENSE IN CRIMINAL PROCEEDINGS

The article deals with the violation of one of the constitutional rights – the right of the suspect (accused) to defense. Violations may also occur in the provision of passive protection by lawyers. The study suggests ways to solve the problem.

Keywords: defender, lawyer, defense, suspect, accused, constitutional rights, passive defense.

В ст. 1 ФЗ «Об адвокатской деятельности и адвокатуре в Российской Федерации»⁵⁸ закреплено, что адвокатская деятельность – это квалифицированная юридическая помощь, которая оказывается на профессиональной основе лицами, получившими статус адвоката в порядке, установленном ФЗ «Об адвокатской деятельности и адвокатуре в Российской Федерации», физическими и юридическими лицами для защиты их прав, свобод и интересов, а также обеспечения конституционного принципа – доступа к правосудию.

Как существенное нарушение уголовно-процессуального законодательства Верховным Судом РФ признан факт необеспечения

⁵⁸ Федеральный закон от 31.05.2020 № 63-ФЗ (ред. от 31.07.2020) «Об адвокатской деятельности и адвокатуре в Российской Федерации» // СЗ РФ. 2020. № 23. ст. 2102; 2020. № 31 (часть I). ст. 5027.

подозреваемому (обвиняемому) права на приглашения по своему усмотрению защитника.

Однако, даже когда в уголовном судопроизводстве участвует защитник, это не исключает того факта, что им может быть оказана пассивная защита. Пассивная защита – это процессуальное бездействие, выраженное в полном либо частичном неиспользовании предоставленных ст. 53 УПК РФ⁵⁹ и ст. 6 ФЗ «Об адвокатской деятельности и адвокатуре в Российской Федерации» полномочия защитником, в виду чего нарушается право гражданина на защиту.

Исходя из анализа судебной практики, уголовное дела не возвращаются на дополнительное расследование, а доказательства не исключаются, если выявляется факт пассивной защиты, а, следовательно, нарушается и ст. 48 Конституции РФ.

Пассивная защита является разновидностью нарушения конституционных прав, а значит и последствия должны быть этому равносильны. Доказательством некачественного оказания адвокатских услуг может послужить заключение квалификационной комиссии адвокатской палаты либо решение Совета, в котором будут отмечены нарушения в действиях или бездействии защитника. Такие нарушения должны противоречить нормам ФЗ «Об адвокатской деятельности и адвокатуре в Российской Федерации» и Кодекса профессиональной этики адвоката.

Таким образом считаем, что в ст. 237 УПК РФ следует указать одним из оснований возвращения уголовного дела на дополнительное расследование – нарушение права подозреваемого (обвиняемого) на защиту, в частности и ненадлежащего оказания услуг защитником.

Считаем, что недоработкой законодателя является факт отсутствия основания для отвода защитника от участия в уголовном деле при ситуации, когда между защитником и его подзащитным разные взгляды на выбор линии защиты. Исходя из этого, считаем необходимым дополнить п. 3 ч. 4 ст. 46, а также п. 8 ч. 4 ст. 47 УПК РФ следующим текстом: «Подозреваемый и обвиняемый вправе в любой момент отказаться от выбранного либо назначенного защитника, заменить его на другого или наряду с ним пригласить несколько защитников».

Использованные источники:

Нормативные правовые акты:

1. Конституция Российской Федерации (принята всенародным голосованием 12.12.1993 с изменениями. Одобренными в ходе общероссийского голосования 01.07.2020) // на Официальном интернет-портале правовой информации <http://www.pravo.gov.ru>, 04.07.2020.

⁵⁹ Уголовно-процессуальный кодекс Российской Федерации от 18.12.2001 № 174-ФЗ (ред. от 31.07.2020) // СЗ РФ. 2001. № 52 (ч.1). ст. 4921; 2020. № 31 (часть I). ст. 5002

2. Уголовно-процессуальный кодекс Российской Федерации от 18.12.2001 № 174-ФЗ (ред. от 31.07.2020) // СЗ РФ. 2001. № 52 (ч. I). ст. 4921; 2020. № 31 (часть I). ст. 5002.
3. Федеральный закон от 31.05.2020 № 63-ФЗ (ред. от 31.07.2020) «Об адвокатской деятельности и адвокатуре в Российской Федерации» // СЗ РФ. 2002. № 23. ст. 2102; 2020. № 31 (часть I). ст. 5027.

*Богомазова В.А.
студент магистратуры 3 курса
ФГБОУ ВО «Курский государственный университет»
Россия, г. Курск*

СИСТЕМА ОРГАНИЗАЦИИ ИННОВАЦИОННОЙ ДЕЯТЕЛЬНОСТИ В КОМПАНИЯХ КОРПОРАТИВНОГО ТИПА

Аннотация: Проблема инновационной деятельности предприятий и корпораций в настоящее время активно обсуждается. Внедрение различного рода инноваций побуждает руководство предприятия к логичным и необходимым изменениям в структуре управления компании. Также подобные изменения должны быть отражены в методах организации управления всем предприятием.

Ключевые слова: финансы корпораций, стратегия развития, система управления, инновационная деятельность, принципы развития инновационной деятельности

*Bogomazova V. A.
master's student 3rd year
Kursk state University*

SYSTEM OF ORGANIZATION OF INNOVATIVE ACTIVITY IN CORPORATE COMPANIES

Abstract: the problem of innovative activity of enterprises and corporations is currently being actively discussed. The introduction of various types of innovations encourages the company's management to make logical and necessary changes in the company's management structure. Also, such changes should be reflected in the methods of organizing the management of the entire enterprise.

Keywords: corporate finance, development strategy, management system, innovation activity, principles of innovation development

Одним из основных условий формирования конкурентоспособной стратегической перспективы корпорации является ее инновационная активность.

Бизнес уже давно пришел к пониманию необходимости осуществления инновационной деятельности. Внедрение инноваций все больше рассматривается им как единственный способ повышения конкурентоспособности производимых товаров, поддержания высоких

темпов развития и уровня доходности. Интерес руководителей компаний к изучению стратегии и организации управления инновациями растет.

Предприятиям стоит особое внимание обратить на ключевые объекты инновации, в особенности на средства производства и технологические процессы; выпускаемую предприятием продукцию и уровень качества; потенциал всех сотрудников, задействованных в производстве. Предприятие так же должно заниматься развитием творческой и активной деятельности всего коллектива; решать вопросы не только связанные с производством продукции, но и соответствующим образом реагировать на все изменения в поведении сотрудников организации [2, с.74].

Инновационная — это та деятельность, при которой главной задачей является получение значимых результатов, используя экспериментальные разработки и различные научные исследования. В конечном итоге результатом должен стать новый или улучшенный продукт, который будет интересен потребителю на рынке. Так же в качестве результата можно рассматривать усовершенствование или оптимизацию технологического процесса, который в дальнейшем будут использоваться на предприятии.

Важно отметить, что внедрение различного рода инноваций, побуждает руководство предприятия к вполне логичным и необходимым изменениям в структуре организации, а так же к изменениям в методах организации управления всем предприятием. Ведь инновации должны быть присущи не только в технологиях производства, но и в управленческой культуре начальников предприятия, так как это способствует к повышению эффективности всего предприятия [3, с.393].

В современных условиях российской экономики особенностью инновационной деятельности является:

- активный обмен между предприятиями достижениями в научной и технической деятельности, что способствует распространению опыта в производстве по всей территории Российской Федерации, включая обмен с иностранными предприятиями;

- двойственность субъектов инновационного рынка, заключается в том, что почти все предприятия, которые создают инновационный продукт, являются его продавцами, представляя свою продукцию на рынке.

Конкуренция на рынке инноваций побуждает руководителей предприятий к активным действиям по улучшению уровня производства продукции, и, соответственно повышению качества производимой продукции, снижать, либо быстро покрывать издержки, тем самым стремясь всячески повысить эффективность инновационной деятельности. Конкуренция — это хороший стимул для любого предприятия, именно конкуренция мотивирует руководителей предприятий более активно заниматься инновационной деятельностью.

Механизмом прогресса инноваций является выбранная приоритетная организационно-экономическая форма реализации предложенных

инноваций и стимулирование ее проведения, формирование инновационной политики, приоритетов ее развития и направлений. Регулирование инновационной деятельности может осуществляться на трех основных уровнях: федеральном, региональном и микроуровне (уровне предприятия) [3, с.394].

В механизме должны быть заложены важные принципы, отвечающие современным условиям ведения инновационной деятельности. Одним из главных условий является участие предприятия в постоянном обучении кадров, а так же переподготовке уже задействованных сотрудников. То есть инновационное предприятие не должно быть простым потребителем трудовых ресурсов, оно должно «выращивать» своих высококвалифицированных кадров.

В основе развития механизма инновационной деятельности предприятия лежат три связанных между собой принципа (рисунок 1).



Рисунок 1 – Принципы развития механизма инновационной деятельности предприятия

К данным факторам относятся нормативно-правовая база, которая является неотъемлемой частью постоянно меняющегося механизма становления инновационной деятельности, правильное и грамотное управление ею, наличие необходимых ресурсов, умение руководства предприятия без особых колебаний интегрировать в науку, производство, внутренний рынок.

Предприятие, нацеленное на инновационную деятельность, обязательно должно трансформировать все компоненты хозяйственной деятельности своей системы. В связи со сложившимися обстоятельствами должно определить свои дальнейшие приоритеты в развитии, выбрать подходящую стратегию. Эволюцией предприятия должно стать взаимодействие стратегической и инновационной деятельности в условиях, когда необходимо быстро принимать важные решения, и реагировать на изменения во внешней среде [1, с.18].

Дальновидный руководитель всегда должен учитывать, что при принятии решений о внедрении инноваций следует учитывать такие стратегические факторы, как анализ внешней среды, наличие финансовых и трудовых ресурсов, и в целом стратегию предприятия. Необходимо учитывать тот фактор, что в ходе принятия важных управленческих решений, внедрение новых технологий могут являться одним из сложных шагов, и проходить для предприятия очень болезненно. Это связано с тем, что реализация инновационной стратегии, обычно ведет к трансформациям по всей структуре и деятельности предприятия, а любые изменения, связанные с совершенствованием какого-либо процесса, являются инновациями.

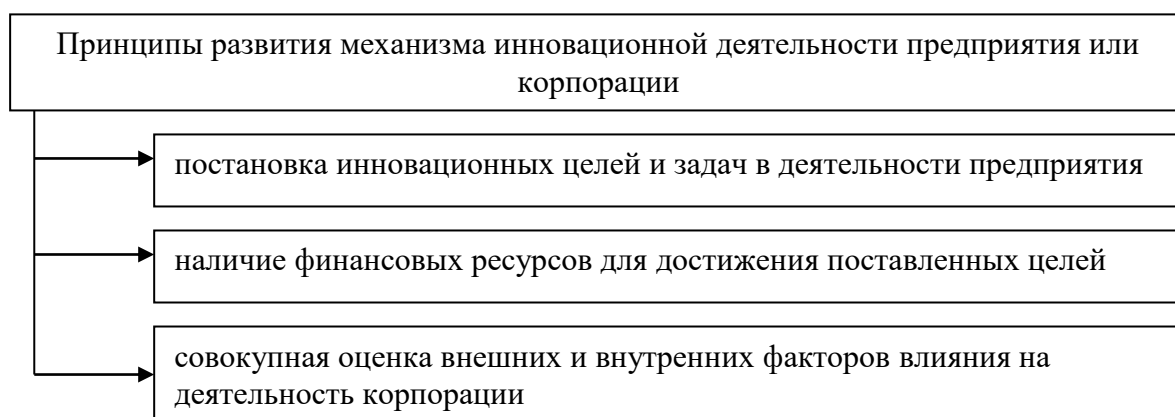
В настоящее время инновации являются шагом вперед для любого предприятия, нацеленного на перспективное развитие, а, это означает, что инновационная и стратегическая деятельности предприятия с развитием рынка полностью объединяются.

Использованные источники:

1. Доржиева Э. Л., Кириллова Т. К. Стратегия социальной ответственности инновационной деятельности корпорации // Вестник Бурятского государственного университета. Экономика и менеджмент. – 2019. – № 2. – С. 17–23.
2. Емельянова О.В., Канищева Е.М. Современное состояние инновационной деятельности российских предприятий // Вестник Алтайской академии экономики и права. – 2019. – №11. – С.72-78.
3. Питилимов Ф.М., Шарышов А.С. Инновационная деятельность предприятия // Young Scientist. – 2016. – №20(124). – С.361-363.

*Борисов А.В.
студент
Вахрамеев Ю.В.
студент
Житков Д.С.
студент*
*Российский государственный университет правосудия
научный руководитель: Власова Е.Л.
Россия, Иркутск*

ОТЛИЧИЯ ПОРЯДКА ОБРАЗОВАНИЯ, ОРГАНИЗАЦИИ И КОМПЕТЕНЦИИ ЗАТО И МО

Аннотация: В ст.1 Закона РФ от 14.07.1992 N 3297-1 (ред. от 29.06.2018)"О закрытом административно-территориальном образовании" (далее Закон РФN 3297-1) дано определение ЗАТО.

ЗАТО — признается имеющие органы местного самоуправления административно-территориальное образование, созданное в порядке, предусмотренном статьей 2 настоящего Закона, в целях обеспечения безопасного функционирования находящихся на его территории организаций, осуществляющих разработку, изготовление, хранение и утилизацию оружия массового поражения, переработку радиоактивных и других представляющих повышенную опасность техногенного характера материалов, военных и иных объектов, для которых в целях обеспечения обороны страны и безопасности государства устанавливается особый режим безопасного функционирования и охраны государственной тайны, включающий специальные условия проживания граждан.

Ключевые слова: Городской округ - тип муниципальных образований; один или несколько объединённых общей территорией населённых пунктов, не являющихся муниципальными образованиями, в которых местное самоуправление осуществляется населением непосредственно или через выборные и иные органы местного самоуправления.

Референдум - форма непосредственного волеизъявления граждан, выражающаяся в голосовании по наиболее значимым вопросам общегосударственного, регионального или местного значения.

Устав — свод правил, регулирующих деятельность организаций, учреждений, обществ, граждан, их взаимоотношения с другими организациями и гражданами, права и обязанности в разных сферах государственного управления, хозяйственной или иной деятельности.

Комиссия — группа лиц или орган, формируемый в составе группы лиц для выполнения каких-либо определённых функций или проведения специальных мероприятий.

Полномочия — ограниченное право использовать ресурсы организации и направлять усилия некоторых сотрудников на выполнение определенных задач.

Чтобы лучше разобраться в данном вопросе стоит сначала выявить отличия нужно дать определение закрытого административно-территориального образования (далее - ЗАТО).

***Borisov A.V.**
student*

***Vahrameev Y.V.**
student*

***Zhitkov D.S.**
student*

*of Russian State University of Justice
Scientific adviser: Vlasova E.L.
Russia, Irkutsk*

DIFFERENCES IN THE ORDER OF EDUCATION, ORGANIZATION AND COMPETENCE OF ZATO AND MO

Annotation: In article 1 of the Law of the Russian Federation of 14.07.1992 N 3297-1 (ed. of 29.06.2018)"About the closed administrative-territorial education" (hereinafter the Law 3297-1 of the Russian Federation) of this definition BUT.

BUT — an administrative-territorial entity that has local self-government bodies and is established in accordance with the procedure provided for in article 2 of this Law in order to ensure the safe functioning of organizations located on its territory that develop, manufacture, store and dispose of weapons of mass destruction, process radioactive and other materials of an increased technogenic nature, military and other objects, for which, in order to ensure the country's defense and state security, a special regime for the safe operation and protection of state secrets is established, including special living conditions for citizens.

Keyword: Urban district - a type of municipalities; one or more settlements united by a common territory, which are not municipalities, in which local self-government is exercised by the population directly or through elected and other local self-government bodies.

A referendum is a form of direct expression of the will of citizens, expressed in voting on the most significant issues of national, regional or local importance.

Charter - a set of rules governing the activities of organizations, institutions, societies, citizens, their relationship with other organizations and citizens, rights and obligations in various areas of government, economic or other activities.

Commission - a group of persons or a body formed as part of a group of persons to perform any specific functions or conduct special events.

Authority - a limited right to use the resources of the organization and direct the efforts of some employees to perform certain tasks.

To better understand this issue, it is worth first identifying the differences, it is necessary to define a closed administrative-territorial entity (hereinafter - ZATO).

В данный момент на территории ЗАТО живет примерно 1.5 млн. человек, это 1 процент от всего населения РФ.

Также стоит отметить, что вся территория закрытого административно-территориального образования является территорией муниципального образования со статусом городского округа. К примеру, на территории Иркутской области расположено 474 муниципальных образований: 32 муниципальных района, 10 городских округов, 67 городских поселений и 365 сельских поселений. Что касается ЗАТО то информация о них засекречена. Нам известно о двух находящихся на территории Иркутской области: Иркутск-45 и Тайшет-24.

Территориально ЗАТО расположены в 22 субъектах РФ всего их 42. Наибольшее число ЗАТО в Московской области и Мурманской. Особенности осуществления местного самоуправления в закрытых административно-территориальных образованиях (ЗАТО) установлены Законом РФ от 14 июля 1992 г. № 3297-1 «О закрытом административно-территориальном образовании».

В соответствии с указанным Законом ЗАТО признается имеющее органы местного самоуправления административно-территориальное образование, созданное в целях обеспечения безопасного функционирования находящихся на его территории организаций, осуществляющих разработку, изготовление, хранение и утилизацию оружия массового поражения, переработку радиоактивных и других представляющих повышенную опасность техногенного характера материалов, военных и иных объектов, для которых в целях обеспечения обороны страны и безопасности государства устанавливается особый режим безопасного функционирования и охраны государственной тайны, включающий специальные условия проживания граждан.

Законом РФ «О закрытом административно-территориальном образовании» установлены следующие особенности правового режима ЗАТО.

Решение о создании, преобразовании или об упразднении ЗАТО принимается Президентом РФ. Предложение о создании, преобразовании или об упразднении ЗАТО вносится Правительством РФ. Предложение об установлении административной подчиненности, об установлении и (или) изменении границ создаваемого или преобразуемого ЗАТО вносится

Правительством РФ по согласованию с органами государственной власти субъектов РФ, в ведении которых находятся соответствующие территории. При отсутствии в административно-территориальном образовании и (или) на соответствующей территории органов местного самоуправления указанные органы формируются в соответствии с законодательством РФ о местном самоуправлении и Федеральным законом «О закрытом административно-территориальном образовании» в течение двух лет со дня создания ЗАТО.

Органы местного самоуправления ЗАТО согласовывают с федеральными органами исполнительной власти, в ведении которых находятся организации и (или) объекты, по роду деятельности которых созданы ЗАТО:

- — планы и программы комплексного социально-экономического развития ЗАТО;
- — генеральный план ЗАТО;
- — подготовленные на основе генерального плана ЗАТО проекты планировки территории;
- — резервирование земель в границах ЗАТО для муниципальных нужд.

Главой местной администрации ЗАТО является лицо, назначаемое на должность главы местной администрации по контракту, заключаемому по результатам конкурса на замещение указанной должности на срок полномочий, определяемый уставом ЗАТО. Структура органов местного самоуправления в ЗАТО – такая же как во всех иных МО.

Общее число членов конкурсной комиссии в ЗАТО устанавливается представительным органом ЗАТО. При формировании конкурсной комиссии в ЗАТО одна треть ее членов назначается представительным органом ЗАТО, одна треть — законодательным (представительным) органом государственной власти субъекта РФ по представлению высшего должностного лица субъекта РФ (руководителя высшего исполнительного органа государственной власти субъекта РФ), одна треть — федеральными органами исполнительной власти, в ведении которых находятся организации и (или) объекты, по роду деятельности которых созданы ЗАТО.

Создание муниципального образования (далее МО) – это процесс образования нового поселения на межселенных территориях.

Субъектами инициативы являются - Граждане, проживающего в населённом пункте, расположенном на межселенной территории (в форме решения входа); Органы МСУ (в форме решения органа); Органы госвласти субъектов РФ (в форме решения органа); Федеральные органы государственной власти (в форме решения органа).

Необходимо согласие населения муниципального района, на территории которого создается поселение, выраженное ПОМО данного Муниципального района. В результате принимается закон субъекта РФ о

создании на межселенной территории вновь образованного поселения. То есть при создании МО учитывается мнение населения в отличии от порядка образования ЗАТО.

Упразднение МО – ликвидация МО на территориях с низкой плотностью сельского населения и в труднодоступных местностях, если численность сельского поселения составляет не более 100 человек и решение будет принято на сходе граждан поселения.

Территория упраздняемого поселения входит в состав муниципального района в качестве межселенного.

Субъекты инициативы упразднения МО

1. Граждане населенного пункта, расположенных на межселенных территориях (в форме решения схода)
2. ОМСУ в форме решения
3. Органы гос. власти субъекта РФ. в форме решения органа
4. Федеральные органы государственной власти. В форме решения органа.

Преобразование МО – объединение, разделение, изменение статуса городского поселения в связи с наделением его статусом городского округа или лишением его статуса городского округа.

Субъектами выступают те же лица, что и при создании МО.

Объединение МО- это процесс слияния 2х или более МО в одно новое МО, в результате которого прекращаются, а их территория права, обязанности, имущество, переходит к новому МО.

Из выше сказанного мы можем сделать вывод что раз предложение о со-здании ЗАТО вносится Правительством РФ, а решение о создании принимает Президент РФ. Также предложение об изменении границ или преобразовании ЗАТО вносится Правительством РФ. В случае же МО инициатива о создании исходит от граждан проживающих в населенном пункте расположенном на межселенной территории после чего создается закон субъекта РФ о создании муниципального образования, в этом и заключается отличие в образовании ЗАТО от МО.

Использованные источники:

1. Федеральный закон от 06.10.2003 № 131-ФЗ «Об общих принципах организации местного самоуправления в Российской Федерации» (ред. от 18.04.2018) // Справочно-информационная система «Гарант».
2. Закон Российской Федерации от 14 июля 1992 г. № 3297-1 "О закрытом административно-территориальном образовании" (ред. от 30.10.2017)// Справочно-информационная система «Гарант».
3. Рекомендации совещания на тему «Практика решения вопросов местного значения органами местного самоуправления в закрытых административных территориальных образованиях», утвержденные решением Комитета Государственной Думы по федеративному устройству и вопросам местного самоуправления от 17.09.2015г. №119/20 //

Информация с официального сайта Комитета государственной Думы по федеративному устройству и вопросам местного самоуправления [//http://komitet4.km.duma.gov.ru/](http://komitet4.km.duma.gov.ru/).

4. Статья о структуре и полномочии органов местного самоуправления в закрытых административно территориальных образованиях <https://cyberleninka.ru/article/n/1-10-struktura-i-polnomochiya-organov-mestnogo-samoupravleniya-v-zakrytyh-administrativno-territorialnyh-obrazovaniyah-zato/viewer>

*Боташева А.Д.
студент магистратуры 3 курса
факультет «ГМУ и политологии»
Бадахова И.Т., к.и.н.
доцент кафедры ГМУ и политологии
ГМУ ОЗО Карачаево-Черкесский государственный университет
имени У.Д. Алиева
Россия, г. Карачаевск*

ВЛИЯНИЕ ПАНДЕМИИ COVID-19 НА СМЕЩЕНИЕ ПОЗИЦИИ МАЛОГО ПРЕДПРИНИМАТЕЛЬСТВА НА ВНУТРЕННЕМ РЫНКЕ РОССИЙСКОЙ ФЕДЕРАЦИИ

Аннотация: В данной статье рассматривается существенная степень влияния текущей пандемии коронавируса COVID-19 на изменение в функционировании сегмента малого предпринимательства на внутреннем рынке страны. Рассмотрены применяемые в рамках государственной поддержки малого предпринимательства меры и оценена степень их эффективности.

Ключевые слова: малое предпринимательство, пандемия, COVID-19, государственная поддержка, коронавирус, экономика, бизнес.

*Botasheva A.D.
3rd year Master's student
Faculty of «GMU and Political Science»
Budagova I.T., Ph. D.
associate Professor of the Department of public and municipal
administration and political science
Karachay-Cherkess State University
named after U. D. Aliyev
Russia, Karachayevsk*

THE IMPACT OF THE COVID-19 PANDEMIC ON THE SHIFT IN THE POSITION OF SMALL BUSINESSES IN THE DOMESTIC MARKET OF THE RUSSIAN FEDERATION

Annotation: This article examines the significant impact of the current coronavirus pandemic COVID-19 on the change in the functioning of the small business segment in the domestic market of the country. The measures applied in the framework of state support for small business are considered and the degree of their effectiveness is evaluated.

Keywords: small business, pandemic, COVID-19, government support, coronavirus, economy, business.

Малое предпринимательство приобрело значительное значение в экономике страны. Экономическая и социальная роль малого предпринимательства заключается в праве граждан свободно использовать свои способности и имущество для осуществления предпринимательской деятельности.

Во всех экономически благополучных странах доля малого бизнеса в производстве ВВП составляет не менее 50 %. В России ситуация иная. Цель этой работы-найти возможности для выживания малого бизнеса в условиях пандемии коронавируса COVID-19.

Деловая активность почти всегда сопряжена с риском, поскольку нет гарантий надлежащего уровня реализации товаров или реализации услуг. Предприниматель в России сталкивается со многими проблемами:

- недостатки и упущения в налоговом законодательстве,
- периодическое отсутствие необходимых экономических ресурсов,
- недобросовестность со стороны крупного бизнеса, например, мощный демпинг, который становится все более заметным из-за сложной ситуации на внутреннем рынке.
- неграмотность самих предпринимателей и высокая кредитная ставка.⁶⁰

Решение этих проблем, по сути, на данный момент является важнейшей задачей государства. Положение малого и среднего бизнеса в России незавидно. С одной стороны, экономика действительно не создала качественного фундамента для развития предпринимательства по историческим причинам.

С другой стороны, развитие бизнеса требует достаточно длительного периода экономической стабильности, в течение которого были бы стабильны правила ведения бизнеса. А в России не было ни одного десятилетия, в котором не было бы какого-то кризиса или существенных изменений в законодательстве

Государство заинтересовано в развитии малого бизнеса и поощряет его, предоставляя налоговые льготы, субсидируемые кредиты, приоритетный доступ к госзаказам и другие преференции. Действующее законодательство предусматривает ряд льгот для малого и среднего бизнеса.⁶¹

Однако нынешнее положение дел и возможности развития были остановлены вспышкой коронавируса в декабре 2019 года. Число

⁶⁰ Влияние Covid-19 на экономику России, Калякина И. М., Аванесян Э.А., Сайфуллин А. С., Московский экономический журнал №6 2020

⁶¹ Федеральный закон от 24 июля 2007 г. N 209-ФЗ "О развитии малого и среднего предпринимательства в Российской Федерации" (с изменениями и дополнениями) [Электронный ресурс]. Режим доступа: <http://base.garant.ru/12154854>

заболевших растет день ото дня. ВОЗ в марте 2020 года объявила всемирную пандемию: зараженные коронавирусом выявляются повсеместно. Китай принял беспрецедентные меры безопасности, изолировав ряд населенных пунктов-сейчас заболеваемость там снизилась.

Но в других странах-особенно в Италии, Иране, Франции, Германии и США-ситуация ухудшается. С приходом второй волны инфекции количество заболеваний резко возросло. Каждый день в России выявляются новые случаи заболевания. Еще до того, как российские регионы начали переходить в режим тотальной самоизоляции вслед за Москвой, основной финансовый удар пандемии несли на себе представители малого и среднего бизнеса: парикмахерские, маникюрные салоны, студии квестовых игр и другие представители сферы услуг.

Несмотря на то, что российское правительство придумывает компенсационные схемы для смягчения последствий пандемии, бизнесмены не скрывают своего подавленного настроения.

Основные проблемы малого и среднего бизнеса в настоящее время (по данным Росстата):

- Падение спроса-39,43 %;
- Невозможность вести бизнес из-за ограничений-36,77 %;
- Дополнительные расходы, связанные с ростом курса валюты-3,67 %;
- Необходимость выплаты заработной платы и арендные обязательства-19,92 %.⁶²

Президент России Владимир Путин в рамках своего послания по коронавирусу пообещал налоговые и кредитные каникулы для малого и среднего бизнеса, который в первую очередь пострадает от пандемии COVID-19. Правительство России определило 22 отрасли, которые в первую очередь могут рассчитывать на господдержку. В список, как ожидается, войдут компании туристического сектора - от агентств до гостиниц, авиаперевозчиков и аэропортов, автоперевозчиков, а также сферы культуры, развлечений и спорта.

Также в списке тех, кто может рассчитывать на "скорую помощь", предприятия общественного питания, организации дополнительного образования и негосударственные образовательные учреждения, организаторы конференций и выставок, а также все те, кто оказывает бытовые услуги населению, от химчисток до парикмахерских и салонов красоты .

В условиях эпидемии коронавируса сегодня страдают практически все отрасли промышленности, в том числе и строительство. Пожалуй, единственными исключениями станут фармацевтическая, логистическая и

⁶² Статистическая информация по малому предпринимательству России (по субъектам Российской Федерации) Ресурсный центр малого предпринимательства. [Электронный ресурс]. Режим доступа: <http://www.rcsme.ru/>.

пищевая отрасли, а также онлайн-торговля. Что делать остальным компаниям в отраслях, которые не считаются затронутыми, пока неясно.

Малый и средний бизнес воспринял объявленные правительством меры поддержки предпринимателей неоднозначно, так как прекрасно понимает трудности взаимодействия с государственной бюрократией. Опрос предпринимателей (по данным Росстата) показал, что:

- Уже воспользовались поддержкой или находятся в процессе ее получения-2.72 %

- Я планирую обратиться за поддержкой – 11.93 %;

- Планирую, но не знаю, куда обратиться за поддержкой -31.39 %;

- Есть проблемы с получением поддержки – 26.10 %;

- Я не планирую просить поддержки – 26.85 %;

В то же время причины отказа в поддержке свидетельствуют о явном пессимизме предпринимателей к государственной заботе:

- Среди мер, предложенных правительством, моя компания не нужна-63,67 %;

- Я не верю, что поддержка будет оказана, будет потрачено только время – 21.64 %;⁶³

- Поддержка не нужна – 14,79 %. Объявленные меры - это позитивный сигнал, но надо дождаться появления регламентов. Кроме того, отсрочка была объявлена довольно короткой, и бизнесу уже нечем платить зарплату. Но правительство пока решило выделить "живые" деньги только в отношении туристической отрасли-туроператорам было выделено 3,5 млрд рублей на компенсацию потерь, связанных с невозвратными тарифами на авиаперевозки и стоимостью вывоза туристов из стран с неблагоприятной эпидемией коронавируса.

Объявленные меры поддержки не являются ни спасительными, ни ключевыми для малого и среднего бизнеса, оказавшегося на передовой в этой борьбе с вирусом. Правительство приняло много положений и мер, чтобы показать, что работа идет, но они мало полезны на практике. Среди основных мер поддержки бизнеса можно назвать льготные кредиты на заработную плату работников, временную отсрочку и рассрочку налоговых платежей, кредитные каникулы, временную отмену арендной платы за муниципальное имущество, снижение страховых взносов с 30 до 15% в ФСС.

Однако трудно выделить хотя бы одну из них, которая действительно помогла бы бизнесу в этой ситуации. Отсрочка и рассрочка платежей не являются отменой, а это значит, что к концу сложного экономического периода компаниям все равно придется искать резервы для выплаты денег. А если учесть, что теперь бизнес должен, по требованию государства, проявлять социальную позицию и выплачивать всем работникам зарплату,

⁶³ Официальный сайт Федеральной службы государственной статистики [электронный ресурс]. Режим доступа: <https://rosstat.gov.ru/>

то получается, что еще предпринимателям нужно будет где-то искать деньги для этого.

Несмотря на то, что предпринимателям нужно думать о текущих расходах. Фактически такие меры господдержки приведут к тому, что наиболее чувствительные сектора МСБ просто не смогут открыться после снятия карантина – не будет оборотных средств. Сюда, прежде всего, следует отнести сферу услуг и развлечений, предприятия общественного питания, рестораны, туристические агентства, торговые точки на арендной основе.⁶⁴

Таким образом, пока вопросов к поддержке властей больше, чем положительных ответов. Фактически получается, что системно значимые предприятия, которые уже пользовались преференциями, будут поддержаны, а бизнес в общей массе останется с трудностями один на один.

Пример решительных действий во всем мире дает нам шанс сделать все правильно сразу, так как это необходимо для развития экономики на долгие годы вперед. А именно, повернуть вспять поток денег в этой "пирамиде" в нужной пропорции: обратно вниз, чтобы оставить деньги бизнесу, сначала для его спасения, потом для развития, и в пользу доходов граждан, позволяя бизнесу сохранить, а потом и приумножить их.

И тогда население сможет выделять на потребление не просто такую же сумму, а скорее увеличит расходы, и деньги успеют работать в более открытой для экономики конкурентной среде, и сами распределятся в пользу наиболее эффективных предприятий, а потом вернутся в казну стократно.

Тратить на бизнес и создаваемые им рабочие места - значит тратить деньги на сохранение доходов семей, которые будут поддерживать все сферы бизнеса, потому что каждый работник частного сектора, нефтяной промышленности и остального государственного сектора является потребителем всех других товаров и услуг в экономике, поэтому без денег для всех в этой цепочке вся экономика окажется под угрозой банкротства.

Использованные источники:

1. Федеральный закон от 24 июля 2007 г. N 209-ФЗ "О развитии малого и среднего предпринимательства в Российской Федерации" (с изменениями и дополнениями) [Электронный ресурс]. Режим доступа: <http://base.garant.ru/12154854>
2. Центр Правовой Поддержки Малого и Среднего бизнеса [Электронный ресурс]. Режим доступа: ek-biz.ru»centr_pravovojj_podderzhki_malogo
3. Влияние Covid-19 на экономику России, Калякина И. М., Аванесян Э.А., Сайфуллин А. С., Московский экономический журнал №6 2020
4. Официальный сайт Федеральной службы государственной статистики [электронный ресурс]. Режим доступа: <https://rosstat.gov.ru/>

⁶⁴ Центр Правовой Поддержки Малого и Среднего бизнеса [Электронный ресурс]. Режим доступа: ek-biz.ru»centr_pravovojj_podderzhki_malogo

5. Статистическая информация по малому предпринимательству России (по субъектам Российской Федерации) Ресурсный центр малого предпринимательства. [Электронный ресурс]. Режим доступа: <http://www.rcsme.ru/>.

*Бочков П.В., кандидат экономических наук
доцент
ФГБОУ ВО Уральский институт ГПС МЧС России
Россия, Екатеринбург
Первушин К.В.
студент магистратуры
ФГБОУ ВО Уральский институт ГПС МЧС России
Россия, Екатеринбург*

ОСНОВНЫЕ ПРОБЛЕМЫ БЕЗОПАСНОСТИ МУНИЦИПАЛЬНЫХ ГОРОДСКИХ ОКРУГОВ

Аннотация: В данной статье рассмотрены основные проблемы развития муниципальных городских округов в части предупреждения и ликвидации чрезвычайных ситуаций природного и техногенного характера.

Ключевые слова: чрезвычайные ситуации, техногенный характер, безопасность, обстановка, муниципальная программа.

*Bochkov P.V., candidate of economic sciences
associate professor
FGBOU VO Ural Institute of State Fire Service of EMERCOM of Russia
Russia, Ekaterinburg
Pervushin K.V.
master student
FGBOU VO Ural Institute of State Fire Service of EMERCOM of Russia
Russia, Ekaterinburg*

MAIN SECURITY PROBLEMS OF MUNICIPAL CITY DISTRICTS

Annotation: This article discusses the main problems of the development of municipal urban districts in terms of the prevention and liquidation of natural and man-made emergencies.

Keywords: emergency situations, technogenic character, security, situation, municipal program.

Проблемы предупреждения и ликвидации чрезвычайных ситуаций природного и техногенного характера приобретают все более острый и актуальный характер. Не только в России, но и во всем мире нарастает озабоченность в связи с возрастающим количеством ежегодно возникающих чрезвычайных ситуаций природного и техногенного характера, увеличением их масштабов, ростом потерь и ущерба.

Складывающаяся обстановка требует принятия мер по совершенствованию управления безопасностью. Сегодня исключить чрезвычайные ситуации нельзя, но существенно снизить число, уменьшить масштабы и смягчить последствия чрезвычайных ситуаций возможно.

Муниципальная программа «Безопасность жизнедеятельности населения в муниципальном образовании «город Екатеринбург» направлена на дальнейшее развитие и совершенствование системы защиты населения и территории городского округа от опасностей, возникающих при ведении военных действий или вследствие этих действий, а также при возникновении чрезвычайных ситуаций природного и техногенного характера [3].

В соответствии со ст. 16 Федерального закона от 06.10.2003 № 131-ФЗ «Об общих принципах организации местного самоуправления в Российской Федерации» определены вопросы местного значения городского округа в сфере безопасности:

- участие в профилактике терроризма и экстремизма, а также в минимизации и (или) ликвидации последствий проявлений терроризма и экстремизма в границах городского округа;
- участие в предупреждении и ликвидации последствий чрезвычайных ситуаций в границах городского округа;
- обеспечение первичных мер пожарной безопасности в границах городского округа;
- организация и осуществление мероприятий по территориальной обороне и гражданской обороне, защите населения и территории городского округа от ЧС природного и техногенного характера, включая поддержку в состоянии постоянной готовности к использованию систем оповещения населения об опасности, объектов гражданской обороны, создание и содержание в целях гражданской обороны запасов материально-технических, продовольственных, медицинских и иных средств;
- создание, содержание и организация деятельности аварийно-спасательных служб и (или) аварийно-спасательных формирований на территории городского округа;
- осуществление мероприятий по обеспечению безопасности людей на водных объектах, охране их жизни и здоровья;
- организация и осуществление мероприятий по мобилизационной подготовке муниципальных предприятий и учреждений, находящихся на территории городского округа [1].

Пунктом 2 ст. 8 Федерального закона от 12.02.1998 № 28-ФЗ «О гражданской обороне» определены полномочия органов местного самоуправления по решению вопросов ГО.

Органы местного самоуправления самостоятельно в пределах границ муниципальных образований:

-проводят мероприятия по гражданской обороне, разрабатывают и реализовывают планы гражданской обороны и защиты населения;

- проводят подготовку населения в области гражданской обороны;

- создают и поддерживают в состоянии постоянной готовности к использованию муниципальные системы оповещения населения об опасностях, возникающих при военных конфликтах или вследствие этих конфликтов, а также при чрезвычайных ситуациях природного и техногенного характера, защитные сооружения и другие объекты гражданской обороны;

- проводят мероприятия по подготовке к эвакуации населения, материальных и культурных ценностей в безопасные районы;

- проводят первоочередные мероприятия по поддержанию устойчивого функционирования организаций в военное время;

- создают и содержат в целях гражданской обороны запасы продовольствия, медицинских средств индивидуальной защиты и иных средств;

- обеспечивают своевременное оповещение населения, в том числе экстренное оповещение населения, об опасностях, возникающих при военных конфликтах или вследствие этих конфликтов, а также при чрезвычайных ситуациях природного и техногенного характера;

- в пределах своих полномочий создают и поддерживают в состоянии готовности силы и средства гражданской обороны, необходимые для решения вопросов местного значения;

- определяют перечень организаций, обеспечивающих выполнение мероприятий местного уровня по гражданской обороне.

Выделяют следующие проблемы сферы реализации муниципальной программы:

- вопросы организации и проведения эвакуации и рассредоточения населения. Это касается вопросов безопасных районов, способов эвакуации и согласования маршрутов эвакуации с органами военного командования.

- требования оснащения учебно-консультационных пунктов для обучения неработающего населения по ГО и защите от ЧС.

- не соответствуют требованиям объемы работы по накоплению и хранению запасов материально-технических, продовольственных, медицинских и иных средств, используемых в интересах ГО и создания резервов материальных ресурсов для ликвидации ЧС, отсутствует соответствующая инфраструктура.

-вопросы обеспечения водно-спасательного отряда капитальными строениями для размещения работников и хранения техники и имущества[2].

Для дальнейшего развития систем мониторинга и прогнозирования ЧС и информационного обеспечения требуется приобретение современного программного обеспечения.

Дефицит специалистов в области ГО, защиты населения и территорий от ЧС, увеличение нагрузки и высокие требования к профессиональной подготовке с одной стороны и проблемы в стимулировании работников с другой стороны, приводят к тому, что у значительной части кадрового состава органов управления отсутствует профильное образование. Растет текучесть кадров, что приводит к снижению эффективности работы учреждений в этой области.

Таким образом осуществление основных мероприятий должно способствовать реализации полномочий органов местного самоуправления в области гражданской обороны, защиты населения и территории от чрезвычайных ситуаций пожарной безопасности и безопасности на водных объектах и совершенствование взаимодействия федеральных органов исполнительной власти и органов местного самоуправления по вопросам комплексного обеспечения безопасности населения и объектов на территории городского округа.

Использованные источники:

1. Федеральный закон от 21 декабря 1994 г. № 68-ФЗ (ред. от 01 апреля 2020 г.) «О защите населения и территорий от чрезвычайных ситуаций природного и техногенного характера»
2. Приказ МЧС России от 28 февраля 2003 г. № 105 «Об утверждении требований по предупреждению чрезвычайных ситуаций на потенциально опасных объектах и объектах жизнеобеспечения»
3. Об утверждении Муниципальной программы «Безопасность жизнедеятельности населения в муниципальном образовании «город Екатеринбург» на 2017–2020 годы»

*Буркут А.
студент магистратуры 3 курса
кафедры Бухгалтерского учета
«РГЭУ (РИНХ)»
Россия, г. Ростов-на-Дону*

ОСОБЕННОСТИ ОТРАЖЕНИЯ В БУХГАЛТЕРСКОМ УЧЕТЕ ОПЕРАЦИЙ ПО ОПЛАТЕ ТРУДА

Аннотация: В статье рассмотрены особенности бухгалтерского учета операций с работниками по оплате труда. Освещен синтетический учет по отражению таких операций. Представлены требования к документальному оформлению бухгалтерского учета операций.

Ключевые слова: бухгалтерский учет, расчеты с персоналом по оплате труда, первичные документы.

*Burkut A.
third year student of magistracy
accounting department
RSUE (RINE)
Russia, c. Rostov-on-Don*

FEATURES OF REFLECTION IN ACCOUNTING OF PAYMENT OPERATIONS

Abstract: The article discusses the features of accounting for transactions with employees on remuneration. Synthetic accounting for reflecting such transactions is highlighted. Requirements for documentary registration of accounting operations are presented.

Keywords: accounting, settlements with staff on remuneration, primary documents.

Учет рабочих и заработной платы ведется в соответствии с действующим законодательством и формами и системами, разработанными в организации. В зависимости от назначения и выполняемых функций, труд может оцениваться в целом за отработанное время, за выполненные заказы/произведенные детали, за выполнение плана, а также за начисление премий за выполнение работ сверх плана и др. Главнейшими задачами бухгалтерского учета труда и платы за него можно определить следующие:

— своевременная и текущая оплата за работу персоналу организации. Расчеты включают расчет заработной платы и других выплат, начисление сумм, подлежащих удержанию и перечислению или наличной выдаче. При

этом важно убедиться в том, что работник знает и согласен, как работодатель собирается заплатить ему деньги, в случае несогласия работник может указать способ, который ему больше нравится: указать выплату наличными, либо предоставить реквизиты своей банковской карты и написать заявление о таком желании. При этом работодатель не может отказать работнику в таком желании либо может получить штраф;

— своевременное и правильное распределение стоимости продукции (работ, услуг), размера заработной платы и отчислений, направляемых в соответствующие фонды. В зависимости от того, в каком отделе трудится работник, основное ли производство, а может, он административный служащий, либо менеджер по продажам, распределяются на финансовые результаты суммы расходов на оплату труда и взносов. По работникам основного производства сумма зарплаты и взносов будет относиться на себестоимость продаж, зарплата служащих будет учитываться в составе управленческих расходов, зарплата работников, связанных с реализацией товаров и услуг, будет относиться на коммерческие расходы. То же самое касается и учета будущих отпусков — они будут включаться в затраты того объекта, что и основная заработная плата;

- группировка показателей по труду и заработной плате для расчетов с органами социального страхования, пенсионными фондами и фондами занятости населения и др. Так, например, при расчетах с внебюджетными фондами отдельно друг от друга учитываются суммы пенсионных взносов работников, трудящихся во вредных и тяжелых условиях труда, и всех остальных.

Дебетуется счет 70 «Расчеты с персоналом по оплате труда»⁶⁵ в корреспонденции со счетами учета денежных средств - наличных и безналичных, в зависимости от того, в какой форме производятся расчеты с работниками.

В случае выплаты работникам зарплаты наличными средствами может возникнуть такая ситуация, что он вовремя не явился за деньгами ввиду болезни, отпуска или командировки. В таком случае бухгалтер «депонирует» не выданную сумму заработной платы, то есть замораживает до фактического получения ее работником в составе кредиторской задолженности на счете 76.04 «Расчеты по депонированным суммам».

В бухгалтерском учете необходимо организовать такой учет работников, чтобы можно было определить конкретную сумму по любому из них на любой момент времени по нужде бухгалтера, обособленно от других работников, с возможностью проследить все виды выплат, удержаний и начислений.

⁶⁵ Приказ Минфина РФ от 31.10.2000 № 94н (ред. от 08.11.2010) [Электронный ресурс]: «Об утверждении Плана счетов бухгалтерского учета финансово-хозяйственной деятельности организаций и Инструкции по его применению». Доступ из справ.-правовой системы «Консультант-Плюс».

В соответствии со ст. 137 ТК РФ⁶⁶ удержания из заработной платы могут производиться только в случаях, предусмотренных законодательством. При этом по распоряжению администрации организации могут производиться следующие удержания (см. рис. 1).



Рис. 1 — Удержания из заработной платы работника

В первом случае рассчитывать на возврат денежных средств от работника можно только в случае его согласия. Если работник добровольно деньги не вернет, тогда удержать можно только через суд. Если ошибка случилась ввиду действий бухгалтера по расчетам вследствие человеческого фактора, то в целях возмещения убытка организация может удержать только с бухгалтера.⁶⁷

Во втором случае удержание допускается, если работником были получены деньги на определенные цели, однако он их не подтвердил и не отработал, сроки предоставления расходных документов и авансового отчета прошли, работник не оспаривает такую ситуацию.

⁶⁶ «Трудовой кодекс Российской Федерации» от 30.12.2001 № 197-ФЗ [Электронный ресурс]: (ред. от 31.07.2020) (с изм. и доп., вступ. в силу с 13.08.2020). Доступ из справ.-правовой системы «Консультант-Плюс».

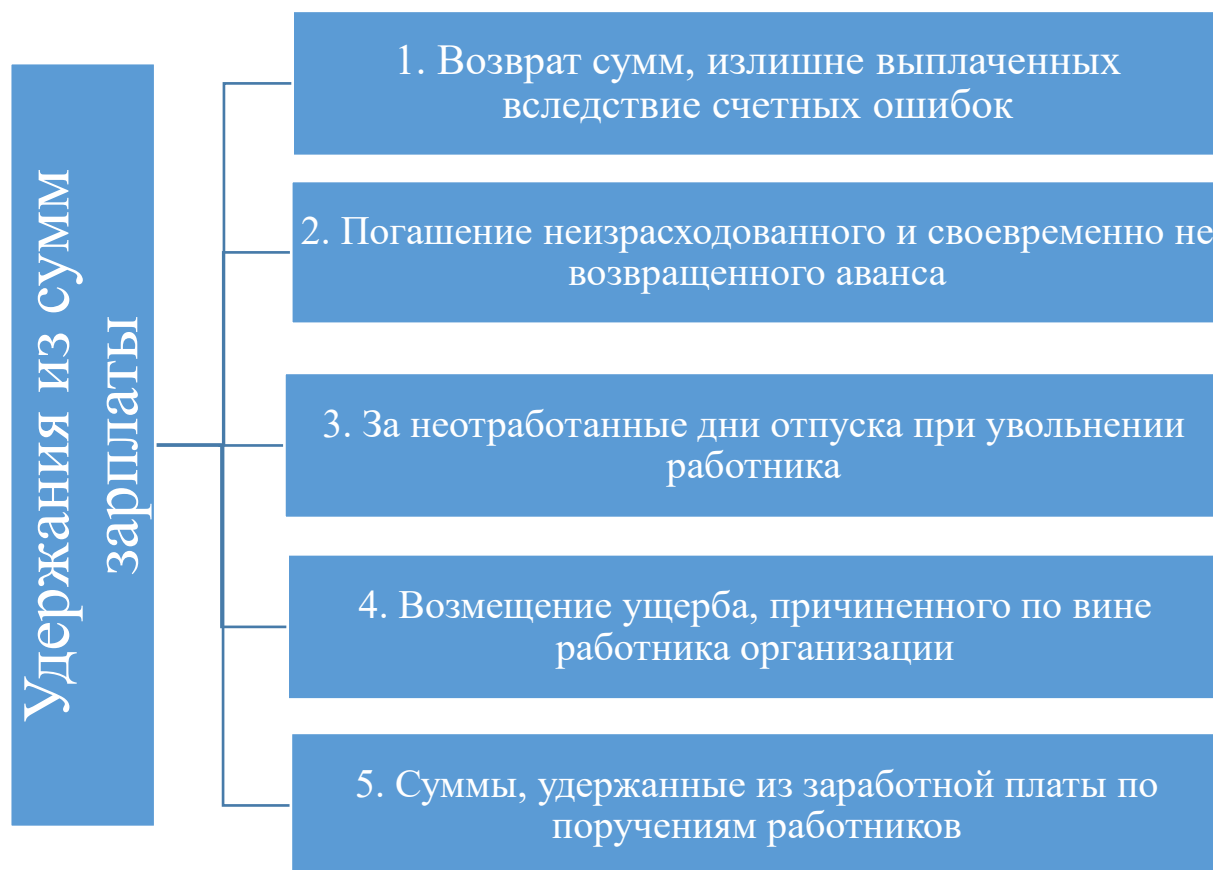
⁶⁷ Ефремова Е.М. Что вычитают из зарплаты / Е.М. Ефремова // Бухгалтер-профессионал автосалона, № 10, — 2010 г.

В третьем случае возможна ситуация, что работник берет отпуск авансом, то есть определенное количество дней еще не накопилось, они не отработаны, однако руководитель идет навстречу, отпускает работника на большее количество дней. Затем работник принимает решение уволиться, не отработав дни отпуска, которые получил ранее. В таком случае при окончательном расчете работодатель имеет право удержать сумму отпускных по такому отпуску в пределах среднего месячного заработка работника, даже если такая сумма не покрывает полностью сумму отпуска.

В последнем случае работник может написать заявление с просьбой удерживать определенную сумму и направления ее адресно — это могут быть выплаты по добровольному страхованию работника, алименты, а также расчеты с банками по ипотечным и другим кредитам.

В соответствии со ст. 136 ТК РФ заработная плата должна выплачиваться работникам не реже чем каждые полмесяца в день, установленный правилами внутреннего трудового распорядка, коллективным договором, трудовым договором.

Начисление заработной платы происходит на основании первичных документов, сформированных начальниками отдельных участков, руководителями бригад и т.д. Начальники также могут принять решение о премировании отдельных эффективных работников, сформировать соответствующее распоряжение и вместе с учетными документами направить в бухгалтерию для принятия в работу. Бухгалтерия, в свою очередь, классифицирует полученные документы, на их основании производит бухгалтерские записи по счетам учета затрат, формирует платежные документы к дате выплаты зарплаты.

Для учета рабочего времени установлены следующие унифицированные формы первичной учетной документации⁶⁸:

- табель учета рабочего времени и расчета оплаты труда (Т-12);
- табель учета рабочего времени (Т-13).

Табели учета рабочего времени применяются во всех организациях, где трудятся наемные работники. С помощью табеля можно фиксировать рабочее время сотрудника, нахождение его в отпуске, на больничном, а также на ночной смене и в др. случаях. Табель оформляет ответственный, уполномоченный на то сотрудник с отражением всех фактов наличия на рабочем месте сотрудников с последующей передачей в бухгалтерию для цели начисления заработной платы.

Для учета расчетов с персоналом по оплате труда установлены следующие унифицированные формы первичной учетной документации (см. рис. 2).

⁶⁸ Постановление Госкомстата РФ от 05.01.2004 № 1 [Электронный ресурс]: «Об утверждении унифицированных форм первичной учетной документации по учету труда и его оплаты». Доступ из справ.-правовой системы «Консультант-Плюс».



Рис. 2 — Первичные документы по учету заработной платы

Для расчета и выплаты заработной платы работникам организации применяются расчетно-платежная ведомость, расчетная ведомость и платежная ведомость.

Выдача наличных денежных средств из кассы организации может производиться по оформленным надлежащим образом платежным и расчетно-платежным ведомостям без составления расходного кассового ордера на каждого работника. Ведомости всех трех видов составляются в одном экземпляре в бухгалтерии. Разрешение на выплату заработной платы подписывается руководителем организации или уполномоченным им на это лицом.

В конце ведомости указываются суммы выплаченной и депонированной заработной платы. На выданную сумму заработной платы

составляется расходный кассовый ордер (КО-2)⁶⁹, номер и дата которого проставляются на последней странице ведомости. Все ведомости на выплату зарплаты заполняются за определенный месяц и затем хранятся вместе с другими учетными документами. Ведомости являются основанием для перечисления или выдачи наличных денег и могут также быть предоставлены по запросам контролирующих органов или аудиторов.

Для расчета причитающейся работнику заработной платы и других выплат при предоставлении ему ежегодного оплачиваемого или иного отпуска применяется унифицированная форма № Т-60 «Записка-расчет о предоставлении отпуска работнику».

Для учета и расчета причитающейся работнику заработной платы и других выплат при прекращении действия трудового договора (контракта) применяется форма № Т-61 «Записка-расчет при прекращении (расторжении) трудового договора с работником (увольнении)». Форма составляется работником кадровой службы или уполномоченным лицом, а расчет причитающейся заработной платы и других выплат производится работником бухгалтерии. При увольнении работника необходимо учесть и отразить все причитающиеся ему выплаты по настоящее время, перепроверить, не выдавался ли ему отпуск авансом и соблюдены ли другие заявления и сроки. Необходимо также убедиться в выдаче на руки работнику всех документов, таких как трудовая книжка, копия приказа на увольнение и справка по форме 2-НДФЛ.

Таким образом, отношения, складывающиеся между работниками и предприятием по поводу выплаты заработной платы, составляют важнейшую часть всего комплекса трудовых правоотношений. Трудовые отношения в нашей стране урегулированы Трудовым Кодексом, и поэтому, именно данный нормативный акт должен служить бухгалтеру главным правовым ориентиром при отражении и учете операций с работниками. На сегодняшний день законодательство постоянно совершенствуется, появляются новые документы и инструкции, имеющие отношение к расчетам по оплате труда на предприятиях всех форм собственности.⁷⁰

Работодатель должен обладать выдающимися профессиональными качествами при работе с сотрудниками предприятия, своевременно учитывать в работе все изменения законодательства, использовать при начислениях и удержаниях актуальную информацию и совершать как можно меньше ошибок при работе с учетными данными.

⁶⁹ Постановление Госкомстата РФ от 18.08.1998 № 88 (ред. от 03.05.2000) [Электронный ресурс]: «Об утверждении унифицированных форм первичной учетной документации по учету кассовых операций, по учету результатов инвентаризации». Доступ из справ.-правовой системы «Консультант-Плюс».

⁷⁰ Ахалкаци Ольга Васильевна. Организация и методика аудита соблюдения трудового законодательства и расчетов по оплате труда. Дис...к.э.н: 08.00.12, 2000 г. — 146 с.

Использованные источники:

1. «Трудовой кодекс Российской Федерации» от 30.12.2001 № 197-ФЗ [Электронный ресурс]: (ред. от 31.07.2020) (с изм. и доп., вступ. в силу с 13.08.2020). Доступ из справ.-правовой системы «Консультант-Плюс».
2. Постановление Госкомстата РФ от 05.01.2004 № 1 [Электронный ресурс]: «Об утверждении унифицированных форм первичной учетной документации по учету труда и его оплаты». Доступ из справ.-правовой системы «Консультант-Плюс».
3. Постановление Госкомстата РФ от 18.08.1998 № 88 (ред. от 03.05.2000) [Электронный ресурс]: «Об утверждении унифицированных форм первичной учетной документации по учету кассовых операций, по учету результатов инвентаризации». Доступ из справ.-правовой системы «Консультант-Плюс».
4. Приказ Минфина РФ от 31.10.2000 № 94н (ред. от 08.11.2010) [Электронный ресурс]: «Об утверждении Плана счетов бухгалтерского учета финансово-хозяйственной деятельности организаций и Инструкции по его применению». Доступ из справ.-правовой системы «Консультант-Плюс».
5. Ахалкаци Ольга Васильевна. Организация и методика аудита соблюдения трудового законодательства и расчетов по оплате труда. Дис...к.э.н: 08.00.12, 2000 г. — 146 с.
6. Ефремова Е.М. Что вычитают из зарплаты / Е.М. Ефремова // Бухгалтер-профессионал автосалона, № 10, — 2010 г.

*Васильева Т.И.
преподаватель кафедры 44
ВИ(ВД)ВУМО РФ
Москва*

КРАТКИЕ ЗАМЕТКИ ОБ ОРКЕСТРОВОЙ ДРАМАТУРГИИ В «РЕКВИЕМЕ» ВЯЧЕСЛАВА АРТЁМОВА

Аннотация: Представлены аргументы, обосновывающие тезис о том, что оркестровые средства выразительности играют важную роль в драматургии «Реквиема» В. Артёмов. Рассмотрено их многообразие и значение в произведении.

Ключевые слова: Артёмов, «Реквием», оркестр, тембры, драматургия.

*Vasilyeva T.I.
Lecturer at the Department 44
of VI (VD)VU MO RF
Moscow*

SHORT NOTES ON THE ORCHESTRAL DRAMATURGY IN “REQUIEM” OF VYACHESLAV ARTYOMOV

Abstract: The article presents arguments that substantiate the thesis that the means of orchestral expressiveness play an important role in dramaturgy of Artyomov's «Requiem». Their diversity and significance are considered.

Keywords: Artyomov, «Requiem», orchestra, timbre, dramaturgy.

Предисловие

Выдающийся российский композитор Вячеслав Петрович Артёмов (1940 г. рожд.) окончил музыкальное училище при Московской консерватории в 1962г. по классу композиции А. И. Пирумова, в 1968г. – Московскую консерваторию по классу композиции Н. Н. Сидельникова.

В совершенстве владея техникой современного музыкального языка, Артёмов первостепенным в музыке считает её духовность. «Музыка - это посредник между Богом и человеком. Музыка – это сгусток духовной энергии, призванный пробудить в человеке нравственное сознание, очистить душу». Композитор говорит, что Болеслав Яворский считал музыкальный романтизм началом психологической эпохи в музыке. «В этом смысле я могу назвать себя романтиком, или точнее – романтическим экспрессионистом: для меня важно экстатическое углубление в тайны духовного мира... Откровение – это изумление перед тайной творения».

В числе сочинений В. Артёмова: «Симфония пути» (тетралогия), симфонии: «Путь к Олимпу», «На пороге светлого мира», «Тихое веянье», «Денница воссияет»; «Реквием»(1985-1988), «Звезда исхода: In Memoriam» (симфония с солирующей скрипкой), «In Spe» (симфония с солирующими скрипкой и виолончелью), «Гурийский гимн», «Симфония элегий», «Гирлянда речитаций», «Tristia 1», Латинские гимны («Pieta», «Tristia II», «Звёздный ветер»), «Гимны внезапных дуновений», «Заклинания», «Moon light Dreams», балет, камерные сочинения, обработки народных песен, музыка к спектаклям и др.

«Реквием» написан для двух сопрано, тенора, баритона, дисканта, двух хоров: смешанного (с двумя солистами: сопрано и басом), хора мальчиков, симфонического оркестра и органа. «Реквием» написан на канонический латинский текст, композитор посвятил его «мученикам многострадальной России». Премьера этого грандиозного монументального произведения состоялась в Москве, в зале им. П. И. Чайковского в ноябре 1988г., дирижировал Дмитрий Китаенко. Это было событие в музыкальной жизни нашей страны, имевшее большой резонанс в мире, благодаря выдающейся художественной ценности музыки. Оно произвело огромное впечатление на слушателей, было записано на грампластинки, транслировалось по телевидению и радио.

«Мой «Реквием» – это музыкальный памятник трагической истории России. Я старался написать музыку величественную, как дух нашего народа, и трагическую, как его судьба», – говорил композитор.

Дирижёр Дмитрий Китаенко был «под невероятным впечатлением, которое граничит с потрясением», от всего того, что он увидел в «совершенно бездонных (по диапазону тех проблем, которые не могут, не имеют права проходить мимо человеческого сердца) партитурах... В. Артёмова».

Некоторые черты драматургии оркестрового письма

Монументальная архитектура «Реквиема» строится на традиционной последовательности частей этого цикла. Драматургия связана с приёмами сопоставления характера частей в связи с текстом и чередованием больших хоровых и оркестровых частей с сольными и ансамблевыми разделами. Используя полифонические приёмы старых мастеров в построении частей, композитор сочетает с ними симфонизм и театральную сценичность, привнесённую композиторами XIX в. трактовку жанра. Сопоставление разных стилистических традиций в частях формы, обогащённых и объединённых приёмами музыкального языка XX века, составляет основную особенность драматургии этого произведения.

Сопоставление является одним из основных приёмов построения формы. Здесь сопоставляются тончайшие оркестровые краски и мощные динамические оркестровые пласты разрастания звука, болезненно напряжённая экспрессия интонаций и сдержанность, суровый аскетизм и

мягкие ариозные эпизоды. Противопоставление образов является основным источником развития. Вечная тема осознания смысла присутствия в этом мире, торжество сил добра или зла, света и тьмы, библейские сцены страшного суда, человеческие радости и страдания, осознание счастья бытия и благодарность. Если мелодическое развитие каждой части композитор строит на развитии одной интонации или мотива, то оркестровое развитие построено на драматургии тембровых пластов. Они редко объединены в одной функции, а чаще имеют свою смысловую роль в фактуре. Композитор широко применяет приём сонорного звучания оркестровых групп, пользуясь выписанными построениями в партиях инструментов, и мыслит крупными масштабами.

Характеризуя формообразующую роль оркестровых приёмов композитора, уместно здесь привести слова Цтирада Когоутека о музыке тембров. «В музыке тембров эмоциональной стороне снова отводится заслуженное, достойное место... развёрнутые звуковые построения и «пласты»... несут в себе динамический, кинетический заряд, обуславливают большую выразительность контрастов, ясность структуры, а тем самым и идейной драматургии, повышают содержательность композиционного процесса».

Вопрос оркестровой драматургии этого произведения интересен в связи с тем, что наряду с великолепными достижениями в области мелодики, гармонии, впечатляющих приёмов драматургии развития и сопоставления хоровых сцен и сольных оазисов, трактовка оркестра играет очень важную роль во всём целом. Оркестр составляет неотъемлемую часть его и так же, как и остальные компоненты музыкального языка, сочетает в себе традиции прошлого и достижения нововенской школы, польского авангарда и выдающихся композиторов XX века.

Рассматривая технологию «Реквиема», можно отметить несколько главных особенностей: сопоставление разных стилистических традиций в частях формы, обогащённых и объединённых приёмами современного языка, наличие основного интонационного ядра произведения, заключающегося в интонации из четырех звуков. Создание развитых мелодических построений, основанных на этой интонации (es, d, c, des), впоследствии включает выразительные и напряжённые ходы на увеличенную кварту и другие интервалы. Основным же интервалом, объединяющим интонационную сферу произведения, является малая секунда. Секвенционность развития и большая насыщенность музыки задержаниями – всё это способствует созданию атмосферы скорби и вместе с тем ритуального объединения чувств скорбящих.

Появление частей, построенных на интонации малой терции или малой сексты, а также на попевах из кварт и больших секунд, связано с образами надежды и веры.

Следуя традиции трактовки жанра и в соответствии с содержанием текста, композитор чередует статичные эпизоды с динамичными, грандиозные и мощные хоровые и оркестровые построения с камерными вокальными ансамблями. В плане тембровой драматургии использует сопоставление частей с нежными детскими голосами и частей драматичных, напряжённых, экспрессивных, использующих солирующие голоса в крайне высоких регистрах. Этот приём, как уже отмечено, является одним из основных в драматургии произведения.

Важное значение имеет также использование приёмов полифонии в построении и развитии музыкального материала. Это касается и вокальных партий, и оркестровых эпизодов. Полифонические приёмы трактованы на современном уровне и включают не только имитационную и контрастную полифонию, но и микрополифонию, а также полифонию оркестровых пластов самостоятельного значения. Композитор отмечал, что полифония для него является «соединением различных фактур, характеров, образов, которые противоречат и дополняют друг друга».

Много лет он работал над поисками выразительной гармонии. В «Реквиеме» В.Артёмов достиг необычайной её красоты и совершенства. Созвучия построены как на традиционной последовательности аккордовых комплексов, так и включают в себя современные кластерные звучания, их параллельные движения, а также аккордовые последовательности, обогащённые диссонансным звучанием. Получается сплав традиционной гармонии, её тяготениями и устоями с современными диссонансными звучаниями кластеров. Но главное – в результате создаётся необыкновенная одухотворённость, накал, откровение звучания музыки.

Остановимся на трактовке оркестра и проанализируем технологию его применения в отдельных частях. Оркестр наряду с хором и солистами является равноправным участником. У него есть и самостоятельные эпизоды – обычно вступления к частям, иногда расширенные до равноправного раздела формы, и сопутствующая роль с остальными участниками действия. Вступления создают атмосферу будущей части, они разные по выбору оркестровых тембров в соответствии с образным содержанием. Они включают использование оркестровых средств для достижения яркой обрисовки образов, их контрастного сопоставления, огромных волн нарастания общего звукового фона, постепенных спадов звучания, необычайной красоты и выразительности звучания в тихих частях и напряжённости накала в кульминациях. Артёмов проявляет огромное мастерство и фантазию во владении оркестровыми средствами.

В произведении использован большой состав симфонического оркестра. Композитору понадобились 4 флейты, 4 кларнета, 4 трубы, орган, большой набор ударных инструментов.

Артёмов сохраняет концепцию традиционной последовательности частей в траурной мессе и канонический латинский текст.

Рассматривая их поближе с точки зрения оркестровых приёмов, использованных автором для создания звукового космоса этого произведения, мы видим, что это сочинение впитало в себя много традиций. Сочетание их и авторское претворение является уникальным в своём роде. Здесь и «психологическая программность позднего романтизма», и экспрессионизм польского авангарда, особенно проявившийся в сочинениях Пендерецкого, и мистицизм Мессиана. В структуре формы и её драматургии прослеживаются традиции многих предшественников от Баха, Моцарта, Бетховена до композиторов XX века. Художник создал крупное полотно, посвящённое трагическим событиям нашей страны. Оно написано вдохновенно, сочетает в себе страшные картины народных бедствий, муки ада и совсем другие образы: материнской любви, детской чистоты, пейзажей природы, веры в добро и справедливость, в разумный смысл бытия.

Эмоциональная насыщенность музыки и драматургия её развития достигается в большой мере и оркестровыми средствами. Композитор следует принципу наслоения звуковых тембровых пластов, имеющих самостоятельную роль, часто в свою очередь состоящих из имитаций одной фигурации или вариантов темы. Полифоническими средствами достигается фоновое оркестровое звучание, его сонорность. Благодаря этому приёму достигаются и огромные разрастания объёмной многослойности звучания, и постепенное достижение кульминационных вершин, хотя *tutti* встречается довольно редко. Всё внимание уделено тембрам групп. Они сочетаются с соответствующими по регистрам группами хора. Для экспрессивного звучания драматических эпизодов Артёмов часто пользуется в оркестровых пассажах методом утолщения. Получается уже единое движение параллельными многозвучными кластерными созвучиями («*Dies irae*») или аккордами.

Сопоставление огромных звуковых комплексов многочисленных *divisi* оркестра в драматических частях с ограниченным применением инструментов оркестра в камерных, лирических частях служат средством создания контрастных образов с помощью тембра. Кроме того, это прозрачность инструментровки создаёт и звуковой противовес накалу напряжённого звучания окружающих частей. Поэтому здесь композитор часто использует красочность тембров инструментов.

В одном примере с помощью сочетания трёх тембров (струнных, фортепиано и вибратона) образуется аккордовый фон сопровождения с жалобной интонацией в верхнем голосе. Она распределяется между двумя инструментами: фортепиано и вибратоном, каждый из которых останавливается на педали, создавая необычный тонкий и выразительный колорит.

Поражает свежесть и тонкость применения оркестровых красок в тихих ансамблевых разделах. В таких местах композитор использует

обычно нежно звучащие струнные, вибрафон, колокольчики, арфы. Вообще вибрафон своего рода лейттемир всего чистого и возвышенного. Обращает на себя внимание и появление новых инструментов с вступлением новых исполнителей – сольных вокалистов или хора, т.е. момент обозначен оркестровыми тембровыми средствами. Тем более новыми группами инструментов и своим оркестровым решением отличается каждая часть. Важны и оркестровые переходы между частями, т.к. многие части следуют без перерыва, благодаря новому звучанию и чередованию статичности и динамичности их.

Как было уже сказано, в формировании оркестровой фактуры большую роль играет принцип полифонии. Благодаря ему композитор может поручить хору очень сложные диссонантные аккорды с секундовым заполнением, кластеры и т.п. В таких местах *divisi* хоровых групп дублируется *divisi* соответствующих по регистру группами оркестра (часто струнными как ближайшими по тембру человеческому голосу).

Большие оркестровые эпизоды, вступления и заключения служат смысловым задачам драматургии, а также вносят разнообразие в тембровую сферу произведения, тем самым создавая формы крупного масштаба и симфонизируя произведение. Использование соответствующих тембров, оркестровых фактур делает их одинаково значимыми, что и хоровые и сольные разделы.

В роли сопровождения оркестр не только рельефно и выразительно дополняет вокальные голоса, тембровыми и фактурными средствами передаёт тот или иной характер музыки, но и значительно увеличивает его выразительность, выделяя ими контрастные хору линии движения, созвучия, реплики или даже стилистически иные диалоговые фразы.

Укажем ещё на продуманность использования и экономию оркестровых тембров, на приёмы создания тембровых педалей, на изобразительные приёмы (голоса птиц в одной части, хлестание бича в «*Dies irae*», переключки трубных сигналов духовых инструментов в «*Tuba mirum*»), вносящие разнообразие в музыкальную драматургию произведения и имеющие смысловое значение.

Основная идейная направленность мессы (от тьмы к свету) передана также средствами использования ударных и клавишных инструментов, арф и органа. Если в начале ударные без определённой высоты звучания используются в музыке для создания драматических сцен, фортепиано применяется в роли ударного инструмента, а орган для создания объёма и величественного звучания в соответствующих эпизодах или на кульминациях, то, начиная от «*Sanctus*», использование вибрана, колокольчиков, челесты и арф, фортепиано (в новой роли, для создания красочных звучностей), органа (тоже в большой степени для создания музыки сфер, отрешённости от земной суеты) становится преобладающим.

Оркестровая педаль используется разными инструментами и в виде дублировки, и вариантно: в виде ритмической, гармонической и мелодической фигурации.

Колеблющаяся, дышащая педаль образуется и полифоническими средствами (с одной стороны- проведение одной ладовой попежки в увеличении и других ритмических вариантах создают ладовый фон, с другой стороны – новый вид ладового фона, созданный канонически проводимой гармонической фигурацией).

Технология создания тембровых слоёв, наряду с интонационным ядром или мотивами и попевками частей, на которых строятся вертикаль и горизонталь этих многоголосных пластов, является также стилистически объединяющим приёмом формы в целом.

Использованные источники:

1. Булез П. Идея, реализация, ремесло. *Nomo musicus: Альманах музыкальной психологии.* М. 1994.
2. Денисов Э. Ударные инструменты в современном оркестре. М. 1982.
3. Денисов Э. Современная музыка и проблемы эволюции композиторской техники. М. 1986.
4. Дмитриев Г. О драматургической выразительности оркестрового письма. М. 1981.
5. Ивашкин А. Кшиштоф Пендерецкий. Музыкальная жизнь. М. 1983.
6. Когоутек Ц. Техника композиции в музыке XX века. М. 1976.
7. Ксенакис Я. Беседы. *Nomo musicus: Альманах музыкальной психологии.* М. 1994.
8. Мессиа́н О. О звуке и цвете (Из бесед с Клодом Самюэлем). *Nomo musicus: Альманах музыкальной психологии.* М. 1994.

Винокуров А.О.
студент магистратуры
ФГБОУ ВО «Сочинский государственный университет»
Российская Федерация, г. Сочи

КУРОРТНЫЙ СБОР

Аннотация: Согласно ст. 1 федерального закона от 29 июля 2017 года № 214-ФЗ «о проведении эксперимента по развитию курортной инфраструктуры в республике Крым, Алтайском крае, Краснодарском крае и Ставропольском крае» в Краснодарском крае будет проводиться «эксперимент по развитию курортной инфраструктуры в целях сохранения, восстановления и развития курортов, формирования единого туристского пространства, создания благоприятных условий для устойчивого развития сферы туризма (далее - эксперимент)».

Эксперимент проводится посредством введения в муниципальных образованиях, территории которых включены в территорию эксперимента, платы за пользование курортной инфраструктурой (далее - курортный сбор) для финансового обеспечения работ по проектированию, строительству, реконструкции, содержанию, благоустройству и ремонту объектов курортной инфраструктуры.

Ключевые слова: курортный сбор, государственная политика, оператор курортного сбора, законодательство по ведению курортного сбора, правовые проблемы, туризм, оператор курортного сбора.

Vinokurov A. O.
graduate student
FSBEI of Higher Education "Sochi State University"
Russian Federation, Sochi

RESORT FEE

Annotation: According to Art. 1 of the federal law of July 29, 2017 No. 214-FZ "on conducting an experiment on the development of resort infrastructure in the Republic of Crimea, Altai Territory, Krasnodar Territory and Stavropol Territory" in the Krasnodar Territory, an "experiment on the development of resort infrastructure in order to preserve, restore and the development of resorts, the formation of a single tourist space, the creation of favorable conditions for the sustainable development of the tourism sector (hereinafter - the experiment)."

The experiment is carried out by introducing in municipalities, the territories of which are included in the experiment territory, fees for the use of resort infrastructure (hereinafter referred to as the resort fee) for financial

support of design, construction, reconstruction, maintenance, improvement and repair of resort infrastructure facilities.

Key words: resort tax, state policy, resort tax operator, legislation on resort tax administration, legal problems, tourism, resort tax operator.

Введение курортного сбора было неоднозначно воспринято российским обществом. И в этом нет ничего удивительного. Ведь сама по себе идея - достаточно спорная. Закон о введении курортного сбора в Алтайском крае, Краснодарском и Ставропольском краях, Республике Крым был подписан президентом России Владимиром Путиным 30 июля 2017 года. Предполагается, что закон вступил в силу уже в 2018 году, а до 2022 года государство будет наблюдать за его реализацией на практике, определяя плюсы и минусы. С 2018 году размер сбора не превышает 50 рублей с человека. В Сочи он составляет всего 10 рублей. На минимальной ставке настояли власти города и региона. К слову, в других регионах, участвующих в экспериментальном проекте, эта сумма выше: на Алтае – 30 рублей, а на Ставрополье – 50. В Краснодарском крае наряду с Сочи курортный сбор ввели на территории Анапы, Геленджика, Горячего ключа, Шепси, Небуга, Джубги и Новомихайловки, а также в 2020 году добавились ряд новых поселений (Тенгинское сельское поселение, Должанское сельское поселение и Ейское городское поселение) От оплаты этого сбора освобождены дети до 18 лет, учащиеся очной формы в возрасте до 24 лет, льготные категории граждан (см. статью 7 Федерального закона №214), а также жители края.⁷¹

Всего за 2020 год в городе Сочи планировалось собрать порядка 98 миллионов рублей. Но в связи с эпидемиологической обстановкой в стране было решено вести мораторий на взимание курортного сбора до конца 2020 года. Сумма курортного сбора после принятия мер составил 0 рублей.

Собранная сумма, согласно плановому показателю, будет направлена на установку объектов курортной инфраструктуры на территории курорта. На набережных города Сочи в 2021 году появятся новые сквер, фото-зоны.

Разберём некоторые проблемы в сфере развития эксперимента по курортному сбору и регулированию объектов средств размещения по включению в реестр операторов курортного сбора:

1. Оператор курортного сбора – это юридическое лицо или индивидуальный предприниматель, осуществляющие в соответствии с законодательством Российской Федерации деятельность по предоставлению гостиничных услуг и (или) услуг по временному коллективному или индивидуальному размещению и (или) деятельность по

⁷¹ Федеральный закон от 29 июля 2017 года № 214-ФЗ "О проведении эксперимента по развитию курортной инфраструктуры в Республике Крым, Алтайском крае, Краснодарском крае и Ставропольском крае"

обеспечению временного проживания (включая деятельность по предоставлению в пользование жилых помещений), в том числе в жилых помещениях.⁷² Оператор курортного сбора, обязан взимать 10 р. в сутки с физических лиц, а именно со своих «гостей», но как показывает практика, многие руководители малых средств размещения платят из «своего кармана», что приводит к тому, что некоторые туристы становятся не в курсе проведения курортного сбора на территории Краснодарского края, а некоторые пользуются «добротой» принимающей стороны.

2. Плательщики курортного сбора – это физические лица, достигшие 18 лет, планирующие проживать в объектах размещения более 24 часов, обязаны уплачивать курортный сбор при поселении в объект размещения.⁷³ Как показывает практика, есть те кто отказываются платить курортный сбор. Таких не много, но по информации Администрации города Сочи, была проведена работа по выявлению и составлению протоколов на физических лиц, которые отказались платить курортный сбор при заселении в средства размещения, таких оказалось более 260 человек. В соответствии со ст. 9.1.1 Закона Краснодарского края от 23 июля № 608 – КЗ «Об административных правонарушениях», неисполнение плательщиками курортного сбора обязанности по уплате курортного сбора – влечет наложение административного штрафа на граждан в размере от 500 до 2000 рублей. На что так и хочется прокомментировать: «дорогие гости нашего прекрасного города, заплатите 10-20-500 руб. курортного сбора, сделаете не только благое дело для города Сочи, в котором вы же провели прекрасные дни отпуска, но и избежите никому не нужной административной ответственности».

Рассмотрим на что же пойдут средства от курортного сбора. За счет средств Фонда развития курортной инфраструктуры подлежат проектированию, строительству, реконструкции, содержанию, благоустройству и ремонту объекты лечебно-оздоровительного, социально-культурного, физкультурно-спортивного и рекреационного назначения, в том числе парки, скверы, городские леса, бульвары, терренкуры, пляжи, набережные, пешеходные зоны, элементы благоустройства, а также иные объекты, способные удовлетворить духовные и иные потребности туристов, содействовать поддержанию их жизнедеятельности, восстановлению и развитию их физических сил, расположенные на территории города Сочи, что позволит благоустроить город в соответствии с требованиями международного стандарта.

⁷² Закон Краснодарского края от 27 ноября 2017 года № 3690-КЗ "О введении курортного сбора на территории Краснодарского края и внесении изменений в Закон Краснодарского края "Об административных правонарушениях"

⁷³ Закон Краснодарского края от 27 ноября 2017 года № 3690-КЗ "О введении курортного сбора на территории Краснодарского края и внесении изменений в Закон Краснодарского края "Об административных правонарушениях"

Работы по благоустройству объектов курортной инфраструктуры будут реализованы в 2021 году.

Использованные источники:

1. Федеральный закон от 29.07.2017 № 214-ФЗ «О проведении эксперимента по развитию курортной инфраструктуры в Республике Крым, Алтайском крае, Краснодарском крае и Ставропольском крае»;
2. Закон Краснодарского края от 27 ноября 2017 года № 3690-КЗ "О введении курортного сбора на территории Краснодарского края и внесении изменений в Закон Краснодарского края "Об административных правонарушениях".

*Гадоев А.
Шарипова Б.
Гадоева Г.
Комилова Х.*

Ферганский государственный университет

ЗАРАЖЕННОСТЬ ДОМАШНИХ ЖИВОТНЫХ САРКОСПОРИДИЯМИ В ЗАВИСИМОСТИ ОТ ВОЗРАСТА

Аннотация: В статье приводятся результаты исследования зараженности некоторых домашних, обитающих в различных экологических условиях Республики Узбекистан, саркоспоридиями в зависимости от возраста.

Ключевые слова: саркоспоридий, паразит, саркоспоридиоз, экстенсивность, интенсивность, внутриутробно, микропрепарат.

*Gadoev A.
Sharipova B.
Gadoyeva G.
Komilova X.
Fergana State University*

INFECTION OF DOMESTIC ANIMALS WITH SARCOSPORIDIA DEPENDING ON AGE

Annotation: The article presents the results of a study of the infection of some domestic animals living in various ecological conditions of the Republic of Uzbekistan with sarcosporidia, depending on age.

Key words and terms: sarcosporidium, parasite, sarcosporidiosis, extensiveness, intensity, in utero, micropreparation.

Саркоспоридий встречается в мышечных клетках внутренних органов у различных видов диких и домашних животных разного возраста.

Литературные сведения о возрастных особенностях заражения животных саркоспоридиями разноречивы. Например: А.С. Степанян (1948) считает, что процент заражения животных с возрастом повышается. Но С.А. Лубянецкий (1956) сообщает о том, что телята часто заражаются саркоспоридиями. Он также отмечает, что саркоспоридиями преимущественно поражается молодняк трёхмесячного возраста: крупный рогатый скот с 7 месяцев до 2-х лет, овцы – от 2 до 6 месяцев. Саркоспоридиозное поражение с возрастом повышается только у свиней.

Исходя из выше приведенных литературных данных нами в 1978 году были исследованы зараженность домашних животных, обитающих в различных экологических условиях Республики Узбекистан. Результаты наших исследований показали что, разница в экстенсивности и интенсивности инвазии характерны только для свиней разного возраста: от 6 до 11 месяцев на 36,06 и 19-28 паразитов соответственно. Результаты исследований крупного рогатого скота и овец показали, что все животные от 6 месяцев до 8 лет и старше оказались на 100% заражёнными саркоспоридиями. Отмечены лишь различия в интенсивности инвазии. Так у крупного рогатого скота в возрасте от 6 до 11 месяцев интенсивность инвазии колеблется от 50 до 60 паразитов, в возрасте 1-2 года – от 156 до 166, в возрасте 2-5 лет – от 130 до 150, в возрасте 5-8 лет и старше – от 175 до 185 паразитов. Таким образом, интенсивность инвазии саркоспоридиями повышается с возрастом животных. Наибольшая интенсивность заражения у крупного рогатого скота наблюдается с 5 лет и старше. Постепенное возрастание процента поражения саркоспоридиями животных с возрастом видимо, зависит от расширения контакта их с очагами инвазии в природе.

Исследованные нами козы, лошади, верблюды и овцы были почти одинакового возраста: козы от 1 до 2 лет, лошади от 5 до 8 лет, верблюды от 8 лет и старше и овцы от 4 до 7 лет. Поэтому выявить разницу в зараженности саркоспоридиями в зависимости от возраста этих видов животных нам не удалось.

Кроме этого, нами было исследовано возможность внутриутробной передачи саркоспоридий и получили отрицательный результат, что подтверждают и литературные данные (Scott, 1918). Однако С.Н. Никольский (1931) наблюдал саркоцисты (*S.hiruta*) в мышцах из лёгких и селезёнок плода коровы. *S.lindemane* (Gertis, 1934) и *S.fusiformis* (Лубянецкий, 1956) передаются трансплацентарным путём. М.Говен (1925) считает, что овцы заражаются саркоцистами внутриутробно.

Н.Г. Левченко и Б.Токбергенов (1962) не обнаружили саркоцисты в мышцах у ягнят, начиная с абортированных плодов и до полуторамесячного возраста, в том числе у 10 ягнят, исследованных вместе с матерями.

Мы, исследовали, 18 экземпляров сердец эмбрионов крупного рогатого скота, 15 экземпляров сердец овец, 12 экземпляров сердец эмбрионов свиней и 15 экземпляров сердец эмбрионов лошадей в возрасте от 4 до 9 месяцев. Ни в одном из препаратов, приготовленных из эмбрионов, саркоцисты не выявлены.

Таким образом, возраст животных влияет лишь на интенсивность инвазии саркоцистами крупного рогатого скота и овец, а экстенсивность их с возрастом повышается только у отдельных видов животных – у свиней.

Использованные источники:

1. Богуш А.А. Саркоцистоз свиней в зависимости от возраста и технологии содержания животных. // Материалы II Всесоюзного съезда протозоологов // ч.3. Киев. 1976.
2. Гадоев А. Саркоцисты крупного рогатого скота в Узбекистане. // Материалы II Всесоюзного съезда протозоологов // ч.3. Киев. 1976.
3. Левченко Н.Г., О внутриутробном заражении овец саркоспоридиями. В кн. «Паразиты сельскохозяйственных животных». Казахстан, Алма-Ата. Изд. АН КазССР. 1962.
4. Токбергенов Б. О внутриутробном заражении овец саркоспоридиями. В кн. «Паразиты сельскохозяйственных животных». Казахстан, Алма-Ата. Изд. АН КазССР. 1962.
5. Лубянецкий С.А. К эпизоотологии саркоспоридиоза. Труды Ульяновского сельскохозяйственного института. Т.4. 1956.
6. Никольский Н.И., Попов А.В. Восприимчивость овец к саркоцистозу. Ветеринария №5. 1985.
7. Степанян А.С. Ветеринарно-санитарная экспертиза мяса буйволов, овец и коз при поражении саркоспоридиозом. Тезисы докладов на конференции патанатомов, ветсанэкспертов и токсикологов сельскохозяйственных вузов и зооветвузов СССР. Казань. 1948.
8. Хан Н.Г. Экспериментальный саркоцистоз овец. Автореферат диссертации кан. вет. наук. Алма-Ата. 1986.
9. Gertis A.T. Sarcosporidia in the niocanilus of the prenatura unfant. J. Pathology. 1934.
10. Scott J.W. Notes and experimenta on Sarcocystis tenella Raullet. Sessonal infection. J.Parasit. 1918.

*Гадоев А.
Туркистанова М.
Гадоева Г.
Комилова Х.*

Ферганский государственный университет

ЗАРАЖЕННОСТЬ ДОМАШНИХ ЖИВОТНЫХ САРКОСПОРИДИЯМИ В ЗАВИСИМОСТИ ОТ ПОЛА

Аннотация: В статье приводятся результаты исследования зараженности домашних животных, обитающих в различных экологических условиях Республики Узбекистан, саркоспоридиями в зависимости от пола исследуемых животных.

Ключевые слова и термины: саркоспоридий, саркоспоридиоз, самки, самец, экстенсивность, интенсивность инвазии, спороцист, ооцист, рефлекс, паразит, поражён.

*Gadoeva A.
Turkistanova M.
Gadoyeva G.
Komilova X.
Fergana State University*

INFECTION OF PETS WITH SARCOSPORIDIA DEPENDING ON SEX

Annotation: The article presents the results of a study of the contamination of domestic animals living in various environmental conditions of the Republic of Uzbekistan with sarcosporidia, depending on the sex of the animals under study.

Key words: sarcosporidium, sarcosporidiosis, females, male, extensiveness, intensity of invasion, sporocysts, oocysts, reflex, parasite, affected.

Саркоспоридий являются внутриклеточными паразитами, они локализуясь в скелетных мышцах, в мышцах и тканях различных внутренних органов оказывают патогенное действие на клетки и ткани этих органов и в целом на организм животного. При саркоспоридиозе молодняк отстает в развитии, взрослые животные теряют продуктивность на 30-40%. Качество мясной продукции резко снижается и при сильной инвазии туши целиком утилизируются (Панасюк Д.Н. и др. 1971).

Надо отметить, что возраст, степень упитанности и пол животного играет известную роль в заражении хозяина различными паразитами, в том числе саркоцистами и развитии у него мышечных цист. Так, С.Н. Мачульский (1947) наблюдал у диких животных в Бурят-Монголии более

частое поражение саркоспоридиями самцов. Саркоспоридиями инвазируются преимущественно самки (Степанян А.С. 1948), особенно у мелкого рогатого скота и свиней (Лубянецкий С.А. 1956): самки овец – 65,58%, самцы – на 32,7%, козы – на 52,8 и 35,6%, свиньи – на 26,7 и 14,3% и крупный рогатый скот – на 56,2 и 48,9% соответственно.

Физиологические особенности самок благоприятствуют распространению указанной инвазии. Мышечная ткань женских особей, устойчивость которой нарушается в период беременности, особенно в условиях неполноценного кормления и неудовлетворительного содержания животных, способствует развитию саркоспоридии в организме хозяина.

Экстенсивность инвазии, обследованных нами сердец самок и самцов крупного рогатого скота и овец в 2014 году в различных ландшафтных зонах Центральной Ферганы Ферганской области Республики Узбекистан составляет 100%. В отношении интенсивности инвазии у указанных видов животных выявлена значительная разница (таблица).

Зараженность саркоспоридиями домашних животных в зависимости от пола.

№	Вид животного	самки				самцы				P ₁ -P ₂ , %
		обследовано	заражено	% заражения	интенсивность инвазии (M±m)	обследовано	заражено	% заражения	интенсивность инвазии (M±m)	
1	Крупный рогатый скот	104	104	100	170±16,0	426	426	100	55±8,0	99,8
2	Овцы	166	166	100	100±11,0	289	289	100	20±3,7	99,9
3	Свиньи	141	52	36,9	17±2,4	165	40	24,0	9±2,0	98,8
4	Козы	40	32	80,0	16±3,0	67	48	71,6	8±1,2	99,5

Экстенсивность и интенсивность инвазии свиней, коз, лошадей, верблюдов, ослов, собак и кур, также сильно различаются: сердца самок свиней заражены на 36,9%, интенсивность инвазии 17±2,4 паразита, у самцов на 24% и 9±2,0, у самок коз на 80% и 16±3,0, у самцов 71,6% и 8±1,2 паразита соответственно. Самки лошадей заражены на 30%, интенсивность инвазии – от 2 до 6 паразитов. Из 50 лошадей инвазирован один самец или 2% с интенсивностью 1-4 паразита.

В сердцах двух самок верблюдов саркоспоридии не обнаружены, но в указанном органе у 7 самцов (из 21) выявлены саркоспоридии или 33,3%, интенсивность инвазии 2-60 паразитов.

У пяти из 12 сердец самок ослов найдены саркоспоридии, что составляет 41,7%, интенсивность инвазии 5-7 паразитов, из восьми самцов ослов саркоспоридии выявлены у трех, интенсивность 2-4 паразита.

Таким образом, можно полагать, что основной причиной более высокой интенсивности заражения самок коз, лошадей, верблюдов, ослов

является необходимость облизывания новорожденных, которые могли быть заражены спороцистами саркоспоридий с пола. У самцов этот рефлекс отсутствует. Низкая зараженность лошадей, верблюдов и ослов по сравнению с зараженностью крупного рогатого скота и овец, объясняется особенностями их питания. Указанные животные, как правило, поедают верхнюю часть растений, тогда как крупный рогатый скот и овцы поедают стебли до основания, касаясь губами и языком почвы.

Из пяти самок собак одна заражена саркоспоридиями, интенсивность 2-4 паразита, из 15 самцов – один, что составляет 6,0%, интенсивность инвазии 1-2 паразита.

Из 124 сердец кур – два или 1,6% поражены саркоспоридиями, интенсивность инвазии 1-3 паразита. Все обследованные петухи (81 экземпляр) оказались свободными от саркоспоридий.

Следовательно, можно сказать, что пол животных играет определенную роль в поражении животных саркоспоридиозом мышечных цист. Вероятно и особенность организма самок способствует распространению среди них саркоспоридиозной инвазии.

Использованные источники:

1. Бейер Т.В. Саркоспоридиоз. «Практик» №5. 2000.
2. Гадоев А., Туркистанова М. Саркоспоридий домашних животных Центральной Ферганы. Научный вестник. ФерГУ. 2014.
3. Мачульский С.Н. Саркоспоридиоз диких животных в Бурят-Монголии. Тр.Бурят-Монгольского зовет.института, вып.3. Улан-Удэ, 1947.
4. Лубянецкий С.А. К эпизоотологии саркоспоридиоза. Труды Ульяновского сельскохозяйственного института. Т.4. 1956.
5. Панасюк Д.Н. и др. К видовой специфичности саркоспоридий. Ветеринария №4. 1971.
6. Степанян А.С. Ветеринарно-санитарная экспертиза мяса буйволов, овец и коз при поражении саркоспоридиозом. Тезисы докладов на конференции патанатомов, ветсанэкспертов и токсикологов сельскохозяйственных вузов и зооветвузов СССР. Казань. 1948.

*Гойинов А.Р.
магистранти
Тошкент кимё-технология институти
Нормуродов И.Ў.
ассистенти
Тошкент кимё-технология институти Шахрисабз филиали
Таджиходжаева У.Б.
доценти
Тошкент кимё-технология институти*

**МОДИФИЦИРЛАНГАН ФЕНОЛ-ФОРМАЛЬДЕГИД
ОЛИГОМЕРЛАРИНИ ТИКИЛИШ ШАРОИТЛАРИНИ
ФЕНОЛОСПИРТ ТАРКИБИГА БОҒЛИҚЛИГИНИ ЎРГАНИШ**

Аннотация: Кейинги вақтларда фенол-формальдегид олигомерларини турли соҳаларда, жумладан, композицион материаллар олишида боғловчи сифатида, қоплама, пластмасса буюмлар ишлаб чиқаришида ва бошқа соҳаларда турли хил моддалар билан модификациялаб ишлатилиб келинмоқда [1]. Аввалги изланишларимиз мобайнида, формальдегиднинг фенолга нисбатан турлича моляр нисбатларида синтез қилинган фенолоспирт ва гидроксил сақловчи полиэфир-полиол асосида модифицирланган фенол формальдегид олигомерини синтез қилган эдик [2].

Калит сўзлар: Модифицирланган фенол-формальдегид олигомерлари; юқори молекула массали фенол-формальдегид олигомерлари; тикилиш шароитлари; фенол спирти; Уббелоде усулида томчи тушиши ҳарорати; гель фракцияси; терморреактивлик ҳоссалари; гидроксил сақловчи полиэфир-полиол (ГСП).

*Гайинов А.Р., магистр
Ташкентский химико-технологический институт
Нормурадов И.У.
ассистент
Шахрисабзский филиал
Ташкентский химико-технологический институт
Таджиходжаева У.Б.
доцент
Ташкентский химико-технологический институт*

**ИЗУЧЕНИЕ ВЛИЯНИЕ СОСТАВА ФЕНОЛА СПИРТА НА
ПРОЦЕСС ВШИВАНИЕ МОДИФИЦИРОВАННЫХ ФЕНОЛ-
ФОРМАЛЬДЕГИННЫХ ОЛИГОМЕРОВ**

Аннотация: В последнее время фенолформальдегидные олигомеры используются в различных областях, в том числе в качестве связующего при производстве композиционных материалов, при производстве покрытий, пластмассовых изделий и других областях с различными веществами [1]. В наших предыдущих исследованиях мы синтезировали фенолформальдегидный олигомер, модифицированный на основе фенол-спирта и гидроксилсодержащего полиэфир-полиола, синтезированных в различных мольных соотношениях формальдегида и фенола [2].

Ключевые слова: модифицированные фенолформальдегидные олигомеры; фенолоформальдегидные олигомеры с высокой молекулярной массой; Условия пошива; фенольные спирты; капля падение температуры методом Уббелоде; фракционный гель; оболочка для терморепактивного агента; гидроксил содержащий полиэфир-полиол (ГСП).

*Gayipov A.R., master
of Tashkent Institute of Chemical Technology
Normuradov I.U.
teaching assistant*

*of Shakhrisabz branch of the Tashkent Institute of Chemical Technology
Tadjikhodjayeva U.B., candidate of technical sciences
docent
Tashkent Institute of Chemical Technology*

STUDY OF THE STRUCTURE CONDITIONS OF MODIFIED PHENOL-FORMALIDID OLIGOMERS ON THE PENOLOGICAL COMPOSITION

Abstract: Recently, phenol-formaldehyde oligomers have been used in various fields, including as a binder in the production of composite materials, in the production of coatings, plastic products and other fields with various substances [1]. In our previous studies, we synthesized phenol formaldehyde oligomer modified on the basis of phenol-alcohol and hydroxyl-containing polyester-polyol synthesized in different molar ratios of formaldehyde to phenol [2].

Keywords: Modified phenol-formaldehyde oligomers; High molecular weight phenol-formaldehyde oligomers; sewing conditions; phenol alcohol; Ubbelode method drop temperature; gel fraction; thermosetting properties; hydroxyl retaining polyester-polyol.

Ушбу ишимизнинг тажриба қисмида эса, формальдегиднинг фенолга нисбатан 1:1 ҳамда 1:1,5 моль/моль нисбатларида синтез қилинган фенолоспирт (ФеС)лар асосида, 1:60 моль/моль нисбатларда

модифицирланган фенол-формальдегид олигомерлари (МФФО)нинг тикилиш шароитларини ўрганишга бағишладик.

Тажриба ишимизнинг дастлабки қисмида, мазкур иккала олигомерларнинг тикилиш жараёнлари ҳамда уларнинг терморреактивлик хоссаларини ўрганишга қаратмоқчимиз.

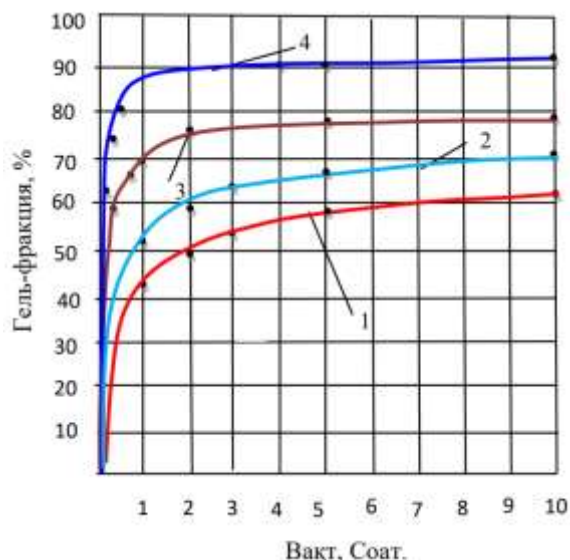

4-график. ГСП÷ФеС(1:1) нинг ўзаро 1:60 моляр нисбатларида синтез қилинган МФФО нинг 1-130°C; 2-150°C; 3-180°C; 4-200°C хароратдаги гель-фракциянинг вақтга боғлиқлигини умумий графиги.

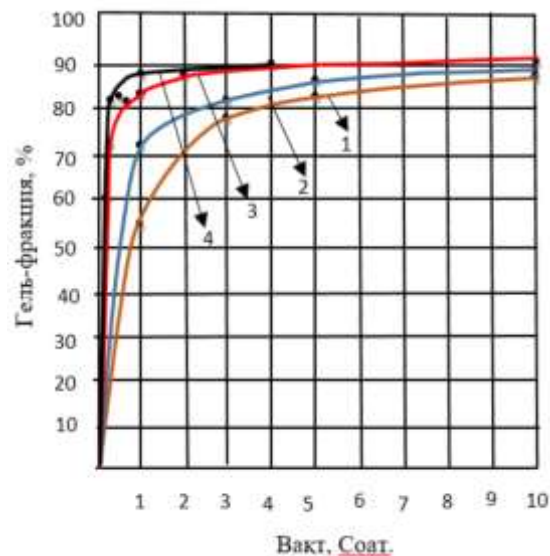

5-график. ГСП÷ФеС(1:1,5) нинг ўзаро 1:60 моляр нисбатларида синтез қилинган МФФО нинг 1-130°C; 2-150°C; 3-180°C; 4-200°C хароратдаги гель-фракциянинг вақтга боғлиқлигини умумий графиги.

Юқоридаги 1-график маълумотлардан кўришиб турибдики, гель фракциялари ҳам олигомерларнинг тикилиши ҳароратига боғлиқ равишда ортиб бормоқда. ГСП÷ФеС (1:1 моль/моль) нинг ўзаро 1:60 моляр нисбатларида синтез қилинган модификацияланган фенол-формальдегид олигомерларидан 130°C ҳароратда гель фракция чиқиши, 1 соатда 43% га тенг бўлса, 200°C да 1 соатда 83% олигомер тикилган ҳолга ўтмоқда.

Фенол-формальдегиднинг 1:1.5 моль/моль нисбатларидан олинган ГСП÷ФеС нинг айна 1:60 моляр нисбатларида олинган МФФО да эса (5-график), 130°C ҳароратда гель фракция чиқиши 1 соатда 55% га тенг бўлса, 200°C да 88% олигомер тикилган ҳолга ўтиши кузатилди.

Демак олигомернинг тикилишида температурадан ташқари унинг молекуляр массаси ҳам катта аҳамиятга эга деб қарайдиган бўлсак, у ҳолда фенол спирти таркибидаги формальдегид микдорининг 1:1 дан 1:1.5 моль/моль нисбатгача ортиши, ГСП ва ФeС асосида модифицирланган фенол-формальдегид олигомерларида нафақат молекуляр масса балки, олигомернинг тикилиш ҳароратининг ҳам ортишига имкон бериши маълум бўлди.

Юқоридаги фикрлани тасдиқлаш мақсадида, айти шу модифицирланган фенол-формальдегид олигомерларини Уббелоде усули бўйича томчи тушиш ҳарорати ўрганилди. Олинган натижалар куйида, график тарзида келтирилган: (3-график).

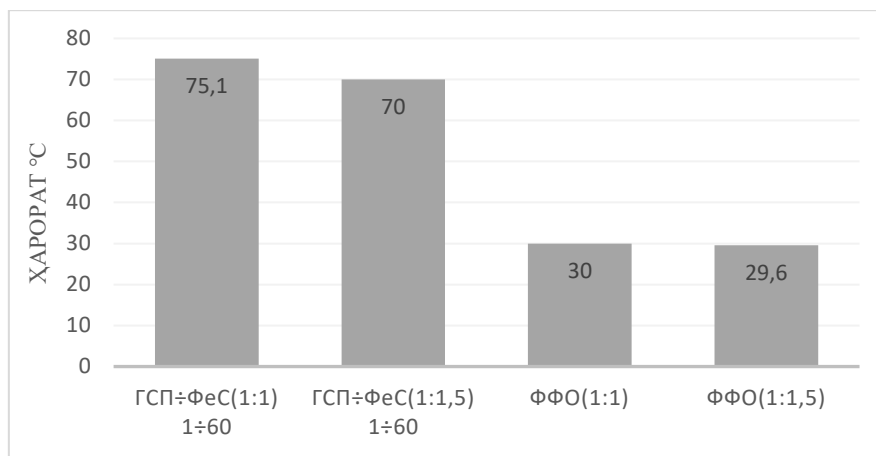

2-график. 1:1 ҳамда 1:1,5 моляр нисбатлардаги ФФО ва ГСП÷ФеС 1:60 олигомерларини Уббелоде усулида томчи тушиш ҳарорати

Келтирилган маълумотлардан кўриниб турибдики, фенолоспирт таркибининг ўзгариши билан, улар асосида модифицирланган фенол-формальдегид олигомерларининг томчи тушиш ҳароратининг ҳам ўзгаришини кўришимиз мумкин. 1:1 моляр нисбатдаги фенолоспиртдан олинган ГСП÷ФеСнинг ўзаро 1:60 моль/моль нисбатларидаги олигомернинг томчи тушиш ҳарорати, иккинчисига нисбатан юқорирок экани намоён бўлди.

Бу эса ўз навбатида 1:1 моль/моль нисбатдаги фенол-формальдегид асосида олинган ГСП÷ФеС 1:60 моль/моль нисбатида олинган олигомернинг молекуляр массаси, 1:1,5 моляр нисбатдаги фенолоспиртдан олинган ЮММФФОнмнг айти нисбатдагисига қараганда юқорирок деган умумий хулосага олиб келиши мумкин. Лекин, 1:1,5 моль/моль нисбатдаги фенолоспиртнинг тармоқланган эканини инобатга олсак, юқоридаги хулосанинг бир мунча ноўрин деб қараш мумкин.

Хулоса ўрнида шуни айтиш мумкинки, ЮММФФО олишда, яъни, ГСП ва ФеС олигомерларини ўзаро модификациялашда фенол спирти таркибдаги формальдегид миқдорининг маълум нисбатгача ортиши, мос равишда олинган МФФО нинг ҳам маълум даражада тармоқланишига сабаб бўлмоқда. Бу эса ўз навбатида, модифицирланган фенол-формальдегид олигомерларининг молекуляр массаси ва айти олигомернинг тикилиш ҳароратининг ортишига олиб келса, унинг Уббелоде усули бўйича томчи тушиш ҳамда желатинланиш ҳароратларининг камайишига сабаб

бўлиши кузатилди. Бундан ташқари ҳароратнинг ортиши билан олигомерларнинг тикилиш даражаси ҳам ортиб бориши аниқланди.

Фойдаланилган адабиётлар:

1. Sushkova S.V., Levanova S. V. Интенсификация производства фенолформальдегидных смоль. Intensification of phenol-formaldehyde resins producing. 15 International Scientific Conference High-Tech in Chemical Engineering – 2014», Zvenigorod, Sept. 22-26, 2014: Abstracts.-М.,2014.-С.314.
2. Ғойипов А.Р., Тохиров М.И., Алимухамедов М.Г., Магрупов Ф.А. Модифицирланган фенол формалдегид олигомерлари компонентларини алоҳида эрувчанлигини ўрганиш.// Кимё, нефт-газни қайта ишлаш ҳамда озиқ-овқат саноатлари инновацион технологияларини долзарб муаммолари илмий-техника анжуманининг материаллари. – Тошкент, 2020.
3. Вахобова А.А, “Исследование влияния молярного соотношения полиэфирполиолов и фурфуролового спирта на термореактивность олигомеров”, Дисс.на соиск.акад.степени магистра 2014,78 с.(ТХТИ)

Гайсина А.В.

студент

научный руководитель: Бухарбаева Л.Я., д.э.н.

профессор

ФГБОУ ВО «Уфимский государственный авиационный технический университет»

СТРАТЕГИЯ РАЗВИТИЯ ЭКОНОМИЧЕСКОЙ ДЕЯТЕЛЬНОСТИ ПРЕДПРИЯТИЯ ТОО «ОМАС ИНТЕГРЕЙТЕД»

Аннотация: Целью данной работы является разработка стратегии развития компании ТОО «Омас Интегрейтед». Оценка деятельности и рынка предприятия, в результате которого компания получает необходимую информацию для разработки долгосрочной конкурентоспособной стратегии.

Ключевые слова: экономика; стратегия; социально-экономическая система эффективности компании; рентабельность.

Gaisina A.V.

Supervisor: Buharbaeva L.Y., d.e.s.

professor

Department of business Economics

FGBOU VO "Ufa state aviation technical University»

STRATEGY OF DEVELOPMENT OF ECONOMIC ACTIVITY OF THE ENTERPRISE "OMAS INTEGRATED" LLP

Abstract: The purpose of this work is to develop a strategy for the development of the company "Omas integrated"LLP. Assessment of the company's activity and market, as a result of which the company receives the necessary information to develop a long-term competitive strategy.

Keywords: Economics; strategy; socio-economic system of the effectiveness of the company's profitability.

ТОО «Омас Интегрейтед» является крупным поставщиком полного комплекса услуг по буровым растворам, растворам заканчивания и ремонта скважин для нефтегазовой отрасли стран СНГ. Компания была основана в Казахстане в 2003 году. Центральный офис компании расположен в г. Актобе, Республика Казахстан. Имеется обширная филиальная сеть на территории стран СНГ, одна из которых находится в Республике Башкортостан.

Стратегическое видение компании ТОО «Омас Интегрейтед» предполагает: концентрацию усилий на сохранении и увеличении доли рынка на традиционных рынках присутствия, переход от региональной структуры рынка к общероссийскому рынку, добавление в портфель заказов новых услуг; внедрение современных технологий производства услуг; поддержание высокого качества услуг; развитие персонала и повышение производительности труда, открытие филиалов в других регионах.[1]

Определим потребности окружающей среды, то есть требования потребителей – заказчиков:

1. Качественное выполнение услуг.
2. Своевременное выполнение услуг.
3. Соблюдение требований норм и стандартов.[2]

Соответственно компания должна стремиться к максимальному удовлетворению потребностей внешней среды. Добиться этого она может за счет своих основных преимуществ, к которым относятся:

1. Комплексный подход к обслуживанию клиентов.
2. Профессионализм, как основного, так и управленческого персонала;
3. Увеличение рентабельности активов и собственного капитала компании. [3]

Следует учитывать интересы и потребности внутренней среды компании.

Персонал компании требует удовлетворения следующих потребностей:

1. Отлаженная система управления и координирования.
2. Возможности карьерного роста.
3. Оплата труда в соответствии с выполняемыми обязанностями
4. Наличие системы мотивации (материальной и моральной).
5. Реализация программ по обучению и повышению квалификации.[4]

Так же отметим роль информационных ресурсов. Это полное оснащение необходимой компьютерной техникой и специализированными программными продуктами. Сотрудники компании обладают достаточным уровнем компьютерной грамотности.

Немаловажную роль играют материальные ресурсы. Сильной стороной предприятия ТОО «Омас Интегрейтед» является достаточность помещений для текущей деятельности, оснащенность рабочих мест, а также наличие всего необходимого для увеличения объемов продаж.

К высокоценным активам компании по регламентам и корпоративному управлению можно отнести лидерство генерального директора, наличие системы стратегического управления, правильно выстроенную организационную структуру управления.[5]

Стратегия организации ТОО «Омас Интегрейтед» - появление новых заказчиков и выход на новые рынки. Они и были положены в основу разработанной деловой стратегии. Появление новых заказчиков и выход на новые рынки благоприятно скажутся на продуктивности организации. Поэтому в дальнейшем указанные возможности объединим в одну общую и разработаем альтернативные варианты ее реализации.

Итак, для увеличения числа клиентской базы рассмотрим следующие альтернативные пути реализации:

1. Создание собственной рекламной программы по продвижению услуг компании;
2. Продвижение услуг с помощью рекламного агентства;
3. Создание сети филиалов в российских регионах.[3]

В основу разработанной деловой стратегии была также положена стратегия создания высококвалифицированного и опытного штата сотрудников, поскольку именно опытные специалисты и инженеры являются основным капиталом компании.

А так же для создания высококвалифицированного и опытного штата сотрудников, состоящего на 60% из опытных работников возможны следующие альтернативные пути реализации:

1. Поиск нужных сотрудников отделом кадров, переманивание специалистов.
2. Поиск нужных сотрудников с помощью рекрутинговых агентств.
3. Инвестирование в развитие имеющихся специалистов.

Предложенные выше альтернативы, как возможные пути достижения стратегических целей, теоретически могут претендовать на свое существование. Однако, воплощение каждого альтернативного решения «в жизнь» требует таких затрат, как материальные, финансовые, человеческие, информационные и временные. Причем сумма затрат по каждой альтернативе будет различной. Поэтому необходимо оценить альтернативы качественно и условно-количественно, чтобы выбрать наименее затратный вариант, соответствующей цели.[1]

Использованные источники:

1. Bell D. The coming of post-industrial society. Venture in social forecasting. – N.Y.: Collman Publ., 1973. – P. 92.
2. Гасанов Э.А., Гасанов М.А. Интеллектуализация инновационной экономики и формирование непрерывного благополучия в России: монография. – Томск: Изд-во ТПУ, 2014. – 264 с.
3. Фролов Д., Рыжкин В. Как построить наноиндустрию? (диалог с Ричардом Коннолли) // Эконо-мист. – 2015. – № 4. – С. 42–51
4. Кац И. На пути к социально-рыночной экономике // Экономист. – 2015. – № 1. – С. 22–26.

5. Гасанов М.А. Структурные сдвиги в условиях трансформации экономики России и становления инновационного типа развития: дис. ... д-ра экон. наук. – Томск, 2012. – С. 298.

*Гильманова Р.Р.
студент 4 курса
Институт права
Башкирский государственный университет
Россия, г. Уфа
научный руководитель: Низамова Г. Х.
преподаватель кафедры гражданского права
Институт права
Башкирский государственный университет
Россия, г. Уфа*

ОСОБЕННОСТИ НАЛОГООБЛОЖЕНИЯ ИНДИВИДУАЛЬНОГО ПРЕДПРИНИМАТЕЛЯ

Аннотация: В данной статье анализируется опыт налогообложения в зарубежных странах, обоснована правильность частичного его использования в отечественной системе налогообложения. Также в статье определяется роль налогообложения индивидуальных предпринимателей на современном этапе развития экономики России.

Ключевые слова: налог, налогообложение, индивидуальный предприниматель.

*Gilmanova R.R.
student
of the Institute of law
Bashkir state University
Russia, Ufa
Scientific supervisor: Nizamova G.Kh.
Lecturer at the Department of Civil Law
Institute of law
of Bashkir State University
Russia, Ufa*

FEATURES OF TAXATION OF AN INDIVIDUAL ENTREPRENEUR

Abstract: This article analyzes the experience of taxation in foreign countries, substantiates the correctness of its partial use in the domestic taxation system. The article also defines the role of taxation of individual entrepreneurs at the present stage of development of the Russian economy.

Key words: tax, taxation, individual entrepreneur.

В Толковом словаре русского языка С. И. Ожегова под налогом понимается установленный обязательный платеж, взимаемый с граждан и юридических лиц⁷⁴. Законодательное определение понятия «налог» представлено в статье 8 Налогового кодекса Российской Федерации. Согласно данной статье: «налог - это обязательный, индивидуально безвозмездный платеж, взимаемый с организаций и физических лиц в форме отчуждения принадлежащих им на праве собственности, хозяйственного ведения или оперативного управления денежных средств в целях финансового обеспечения деятельности государства и (или) муниципальных образований»⁷⁵.

В конце прошлого столетия отношение к предпринимательству в передовых странах приобрело новый оборот развития, который связан с переносом акцента на культивирование налоговой и гражданской дисциплины.

Исходя из анализа последних показателей, которые отражают положение субъектов малого предпринимательства в нашей стране⁷⁶, можно увидеть тенденцию возрастания числа индивидуальных предпринимателей.

В соответствии со статьей 4 Федерального закона «О развитии среднего и малого предпринимательства в Российской Федерации» от 24.07.2007 № 209: «к субъектам малого и среднего предпринимательства относятся зарегистрированные в соответствии с законодательством Российской Федерации хозяйственные общества, товарищества, партнерства, производственные и потребительские кооперативы, крестьянские (фермерские) хозяйства и индивидуальные предприниматели»⁷⁷.

Осуществление деятельности в статусе индивидуального предпринимателя предоставляет ряд преимуществ, если сравнить с осуществлением деятельности юридическими лицами. Так, первые наделены правом пользоваться упрощенной процедурой регистрации, представления отчетности и т. д.

Нынешний зарубежный опыт налогообложения доходов от предпринимательской деятельности характеризуется разделением в развитых экономических странах организационно-правовых форм бизнеса на 2 основные категории – некорпоративную и корпоративную.

⁷⁴ Ожегов С. И. Толковый словарь русского языка : 100 000 слов, терминов и выражений. М. : Оникс, 2018. С. 283.

⁷⁵ Налоговый кодекс Российской Федерации от 31 июля 1998 г. № 146-ФЗ (с послед. изм., внесенными ФЗ № 219-ФЗ от 20.07.2020). [Электронный ресурс]. URL: http://www.consultant.ru/document/cons_doc_LAW_19671/ (дата обращения: 05.11.2020).

⁷⁶ Федеральная служба информации: сайт. URL: <https://xn--h1ari.xn--p1ai/Main/StatisticalInformation> (дата обращения: 05.11.2020).

⁷⁷ Федеральный закон от 24 июля 2007 г. № 209-ФЗ (с послед. изм., внесенными ФЗ № 169-ФЗ от 08.06.2020). [Электронный ресурс]. URL: http://www.consultant.ru/document/cons_doc_LAW_52144/ (дата обращения: 05.11.2020).

Предприниматели, физические лица, товарищества входят в число участников некорпоративной категории и платят индивидуальный подоходный налог. Налогообложение доходов предпринимателей в данном экономическом секторе осуществляется у конечного получателя - физического лица на основе включения их в совокупный доход налогоплательщика.

Исходя из опыта налогообложения участников некорпоративного экономического сектора зарубежных стран, в нашей стране, в целях стимулирования малого предпринимательства, а именно уменьшения конкуренции, на взгляд автора, необходимо устранить юридические лица из числа субъектов малого предпринимательства. И в связи с этим, независимо от того, как предприниматель будет осуществлять свою деятельность (самостоятельно или кооперативно с другими субъектами) налогообложение доходов должно производиться персонально у каждого партнера на основе включения в индивидуальную декларацию о совокупном годовом доходе.

Также необходимо отметить, что анализ норм действующего законодательства показывает, что индивидуальный предприниматель в качестве налогоплательщика имеет двойное правовое положение.

С одной стороны, он подпадает под действие норм законов, которые устанавливают налоговые обязанности для юридических лиц. Так, они обязаны уплачивать следующие налоги:

- транспортный налог,
- акцизы и иные налоги и платежи.

С другой же стороны, рассматриваемый субъект должен платить налоги, которые обязательны для физических лиц. Сюда относятся:

- налог на доходы физических лиц,
- налоги на недвижимость и др.

Мы полагаем, что в России перечень налогов, которые должен уплачивать индивидуальный предприниматель, является довольно большим. По этой причине, в субъектах РФ предпочтительно отменить целевые налоги и сборы, поскольку такое количество налогов препятствует развитию малого предпринимательства.

Исходя из этого, видится, что передача субъектам РФ права в пределах своих полномочий регулировать вопросы, связанные с налогообложением, является правильной. Так, к примеру, одним из первых данное право было реализовано в Краснодарском крае, где, например, сборы за право торговли, за парковку и другие, заменены региональным налогом с продаж.

Таким образом, в нашей стране число налогов, которые должен уплачивать индивидуальный предприниматель, является большим, что замедляет развитие предпринимательства. Индивидуальные предприниматели нуждаются в реальной поддержке со стороны

государства. Мы предполагаем, что для стимулирования субъектов малого и среднего предпринимательства необходимо снизить налоговую нагрузку, например, с момента регистрации, можно использовать режим освобождения от уплаты налогов в той части, которая поступает в федеральный бюджет на первые три года с момента начала осуществления индивидуальной предпринимательской деятельности. На наш взгляд, данное мероприятие повысит степень добросовестности налогоплательщиков, а также будет способствовать увеличению числа индивидуальных предпринимателей.

Использованные источники:

1. Налоговый кодекс Российской Федерации от 31 июля 1998 г. № 146-ФЗ (с послед. изм., внесенными ФЗ № 219-ФЗ от 20.07.2020). [Электронный ресурс]. URL: http://www.consultant.ru/document/cons_doc_LAW_19671/ (дата обращения: 05.11.2020).
2. Федеральный закон от 24 июля 2007 г. № 209-ФЗ «О развитии среднего и малого предпринимательства в Российской Федерации» (с послед. изм., внесенными ФЗ № 169-ФЗ от 08.06.2020). [Электронный ресурс]. URL: http://www.consultant.ru/document/cons_doc_LAW_52144/ (дата обращения: 05.11.2020).
3. Федеральная служба информации: сайт. URL: <https://xn--h1ari.xn--p1ai/Main/StatisticalInformation> (дата обращения: 05.11.2020).
4. Ожегов С. И. Толковый словарь русского языка : 100 000 слов, терминов и выражений. М. : Оникс, 2018. 1376 с.

*Гильманова Р.Р.
студент 4 курса
Институт права
Башкирский государственный университет
Россия, г. Уфа*
*научный руководитель: Файзуллина А.А., к.ю.н.
доцент кафедры криминалистики
Институт права
Башкирский государственный университет
Россия, г. Уфа*

ПРЕДЪЯВЛЕНИЕ ДЛЯ ОПОЗНАНИЯ

Аннотация: В данной статье рассматриваются различные точки зрения определения цели предъявления для опознания, анализируются соотношения категорий «задачи» и «цели» предъявления для опознания. А также предлагается законодательно закрепить цель рассматриваемого следственного действия.

Ключевые слова: предъявление для опознания, следственное действие, цель, задачи.

*Gilmanova R.R.
student
of the Institute of law
Bashkir state University
Russia, Ufa*
*Scientific supervisor: Faizullina A.A.
Associate Professor at the Department of Criminology
Institute of law
of Bashkir State University
Russia, Ufa*

PRESENTATION FOR IDENTIFICATION

Abstract: This article discusses various points of view of determining the purpose of presentation for identification, analyzes the relationship between the categories of "task" and "purpose" of presentation for identification. It is also proposed to legislate the purpose of the investigative action under consideration.

Key words: presentation for identification, investigative action, purpose, objectives.

Предъявление для опознания представляет собой процессуальное действие, которое состоит в предъявлении следователем или судом свидетелю, потерпевшему, подозреваемому или обвиняемому похожих объектов для решения вопроса о наличии или отсутствии тождества либо родовой принадлежности с объектом, которое ранее было предметом восприятия опознающего⁷⁸.

Цели производства многих следственных действий определяются в самом Уголовно-процессуальном кодексе Российской Федерации⁷⁹ (далее – УПК РФ). Однако в статье 193 УПК РФ не только не раскрывается сущность предъявления для опознания, но и не называется цель данного следственного действия, что привело к наличию многих различных суждений по данному вопросу. Хотелось бы проанализировать некоторые из них. Так, А. Г. Филиппов придерживается точки зрения, что цель предъявления для опознания заключается в том, чтобы опознающий ответил: является ли предъявляемый объект тем самым, который он видел прежде в связи с какими-либо фактами, которые имеют отношение к расследуемому событию⁸⁰. А. А. Топорков считает, что целью и задачей предъявления для опознания является установление тождества предъявляемого объекта по его мысленному образу, который запечатлен в памяти опознающего. Однако анализ существующих определений цели и задач предъявления для опознания позволяет сделать вывод, что в уголовно-процессуальной теории происходит смешение категорий «цель» и «задача».

По нашему мнению, утверждение, что цель предъявления для опознания - это установление тождества, является не совсем верным. Поскольку цель предъявления для опознания заключается в установлении тождества или различия ранее воспринимавшегося объекта свидетелем, потерпевшим, подозреваемым или же обвиняемым. Еще одним дискуссионным положением в теории является утверждение, что целью предъявления для опознания выступает не только установление тождества или различия предъявленного объекта, но и их групповой принадлежности. Проанализировав различные точки зрения, можно прийти к выводу, что установление групповой принадлежности возможно в рамках других следственных действий, например, в рамках допроса, следственного эксперимента, осмотра предметов.

Целью предъявления для опознания, на наш взгляд, является установление тождества или различия опознаваемого объекта с мысленным образом, сохранившимся в процессе восприятия ранее и которое имеет отношение к событию преступления.

⁷⁸ Ищенко Е.П., Топорков А.А. Криминалистика: Учебник. — 2-е издание. — М.: ИНФРА, 2016. С. 125

⁷⁹ «Уголовно-процессуальный кодекс Российской Федерации» от 18 декабря 2001 г. № 174-ФЗ (с посл. изм. и доп. от 24 марта 2020 г. № 6-П) // Официальный интернет-портал правовой информации [Электронный ресурс]. URL: <http://www.pravo.gov.ru> (дата обращения: 05.12.2020).

⁸⁰ Филиппов А. Г. Криминалистика: учебник для прикладного бакалавриата. 3-е изд., перераб. и доп. Москва: Издательство Юрайт, 2019. С. 208.

Мы предполагаем, что необходимо закрепить данное определение цели предъявления для опознания законодательно, изложив в следующей редакции пункт 1 статьи 193 УПК РФ: «Следователь может предъявить для опознания лицо или предмет с целью установления тождества или различия опознаваемого объекта с мысленным образом, сохранившимся в процессе восприятия ранее и которое имеет отношение к событию преступления, свидетелю, потерпевшему, обвиняемому, подозреваемому. Для опознания может быть предъявлен труп».

Исходя из всего вышесказанного, можно сделать вывод: основание представляет собой информацию, которая дает возможность полагать, что цель опознания, заключаемая в установлении тождества или различия опознаваемого объекта с мысленным образом, сохранившимся в процессе восприятия ранее, и, которая имеет отношение к событию преступления, будет достигнута, и на основе этого будут сформированы доказательства.

Использованные источники:

1. «Уголовно-процессуальный кодекс Российской Федерации» от 18 декабря 2001 г. № 174-ФЗ (с посл. изм. и доп. от 24 марта 2020 г. № 6-П) // Официальный интернет-портал правовой информации [Электронный ресурс]. URL: <http://www.pravo.gov.ru> (дата обращения: 05.12.2020).
2. Ищенко Е. П., Топорков А. А. Криминалистика: Учебник. - 2-е издание. М.: ИНФРА, 2016. 306 с.
3. Филиппов А. Г. Криминалистика: учебник для прикладного бакалавриата. 3-е изд., перераб. и доп. Москва: Издательство Юрайт, 2019. 466 с.

*Головин А.А., д.э.н.
доцент
Скиба М.С.
студент*

*ФГБОУ ВО «Юго-Западный государственный университет»
научный руководитель: Пархомчук М.А., д.э.н.
доцент
ФГБОУ ВО «Юго-Западный государственный университет»*

КАЧЕСТВО ОКАЗАНИЯ МУНИЦИПАЛЬНЫХ УСЛУГ НАСЕЛЕНИЮ И ПУТИ ЕГО СОВЕРШЕНСТВОВАНИЯ

Аннотация: В данной статье затрагивается вопрос оценки качества оказания муниципальных услуг в электронной форме. Получение обратной связи от заявителя является стимул для дальнейшего совершенствования данной системы.

Ключевые слова: муниципальные услуги, оказание, оценка качества, электронная форма.

*Golovin A.A., Doctor of Economics
Associate Professor
Skiba M.S.
student*

*South-Western State University
Research Supervisor: Parkhomchuk M.A., Doctor of Economics
Associate Professor
South-Western State University*

QUALITY OF MUNICIPAL SERVICES TO THE POPULATION AND WAYS TO IMPROVE IT

Abstract: This article addresses the issue of evaluating the quality of municipal services rendered in electronic form. Receiving feedback from the applicant is an incentive for further improvement of this system.

Keywords: Municipal services, rendering, quality assessment, electronic form.

Доступность и качество государственных и муниципальных услуг являются важнейшими критериями оценки эффективности их предоставления органами государственного и муниципального управления в рамках административной реформы. При этом, на законодательном уровне крайне нечетко установлено само определение данных понятий. Нет

единообразной позиции и среди исследователей. Поэтому актуальным представляется осуществление анализа теоретических подходов к исследованию понятий качества и доступности государственных и муниципальных услуг, а также нормативно-правовых основ оценки качества и доступности предоставления государственных и муниципальных услуг как важнейших направлений деятельности органов государственного и муниципального управления.

В настоящее время совершенствование системы оказания государственных и муниципальных услуг в электронной форме является приоритетным направлением административной реформы в Российской Федерации. Система оказания муниципальных и государственных услуг в электронной форме является одной из составных частей электронного правительства. Мировой опыт показывает, что внедрение информационных технологий в систему взаимодействия власти и общества имеет как положительные, так и отрицательные стороны. Информационное взаимодействие граждан и власти требует постоянного контроля и совершенствования данного процесса. Получение положительной «обратной связи» от граждан должно являться основным критерием работоспособности указанного процесса. То есть оценка качества процесса оказания государственных и муниципальных услуг в электронном виде одним из основных моментов на который, поставщик услуг должен обращать внимание.

Федеральный закон от 27.07.2010 г. № 210-ФЗ «Об организации предоставления государственных и муниципальных услуг» является одним из главных, который регулирует сферу оказания государственных и муниципальных услуг в электронном виде. «В нем нашли отражения основные требования, предъявляемые к процессу оказания услуг, но то же время необходимо отметить, что вопросы его качества остались практически не раскрытыми. Только в одной статье 210-ФЗ, относящейся к стандарту оказания услуги, мы находим упоминание показателей ее доступности и качества» [1].

Анализ применяемых методик оценки качества предоставляемых государственных услуг показал, что в большинстве анализируемых субъектах Российской Федерации для этого используются методы анкетного мониторинга организаций, оказывающих услуги и социологические опросы.

К параметрам, используемым для оценки качества предоставления государственной услуги относятся:

- структурированные параметры, закрепленные регламентами или полученные по факту оказания услуги (время получения услуги, плановое время исполнения, возможность обжалования действий персонала, соблюдение норм потребления товаров и услуг при оказании государственных услуг т.п.);

- результаты анкетирования как поставщиков, так и потребителей услуг (доступность услуги для потребителя, компетентность персонала, степень удовлетворенности качеством оказания услуги, условия обслуживания (удобство, вежливость, время оказания государственной услуги, полнота выполнения процедур, необходимых для оказания государственных услуг и т.п.)» [2].

Также к критериям оценки качества предоставления государственных и муниципальных услуг может осуществляться по следующим критериям:

- время предоставления государственных и муниципальных услуг;
- время ожидания в очереди при получении государственных и муниципальных услуг;
- вежливость и компетентность сотрудника, взаимодействующего с заявителем при предоставлении государственных и муниципальных услуг;
- комфортность условий в помещении, в котором предоставлены государственные и муниципальные услуги;
- доступность информации о порядке предоставления государственных и муниципальных услуг.

Если рассматривать оценку качества оказания муниципальных и государственных услуг в электронной форме, то как правило обратная связь с потребителем услуги сводится к заполнению им анкеты об удовлетворенности процессом получения услуги. Нежелание потребителей государственных и муниципальных услуг заполнять всевозможные анкеты и опросники для получения их мнения об использовании информационного ресурса. Данный процесс занимает время и утомляет, так как зачастую указанные анкеты состоят из однотипных вопросов.

Анкетирование граждан с целью выявления уровня их удовлетворенности процессом и результатом получения государственной или муниципальной услуги является субъективным показателем качества. Данный показатель основан исключительно на оценочных суждениях и мнениях потребителей услуг и представителей общественных организаций, этот показатель качества также является сложносоставным и дробным. Также следует учитывать и объективный показатель качества эффективности системы оказания государственных и муниципальных услуг в электронном виде. К объективным показателям следует отнести внедрения регламентов и исполнения порядка предоставления государственных и муниципальных услуг в соответствии с регламентами. Это сложный собирательный показатель, состоящий из набора более дробных индикаторов и индексов, отражающих соответствие процесса предоставления государственных и муниципальных услуг принятым административным регламентам [3].

Таким образом, можно сделать вывод о том, что государственные и муниципальные услуги в наше время играют роль «моста» между физическими/юридическими лицами и государством по вопросам решения

различных ситуаций, сопровождающиеся документальными процедурами. Меры по предоставлению государственных и муниципальных услуг четко регламентированы, и направлены в текущий момент времени на снижение временных, административных, материальных издержек на их реализацию. Первоначально идея сокращения издержек и повышения доступности граждан к перечню государственных и муниципальных услуг была заложена в создании единых многофункциональных центров и Концепции формирования электронного правительства. Индивидуальный подход, стремление помочь в решении различных ситуаций, грамотная документальная концепция - вот к чему стремится сама идея создания многофункциональных центров.

Использованные источники:

1. Погодина Е. А., Мингачев Р. М. Организация и оценка качества предоставления государственных и муниципальных услуг в электронном виде // УЭКС. 2017. №6 (42). URL: <https://cyberleninka.ru/article/n/organizatsiya-i-otsenka-kachestva-predostavleniya-gosudarstvennyh-i-munitsipalnyh-uslug-v-elektronnom-vidе> (дата обращения: 18.11.2020).
2. Воронина Л.И., Костина С.Н., Томильцев А.В. / под общ. ред. проф. Т. М. Резер *Функции и услуги в системе государственного и муниципального управления: монография* /; М-во образования и науки Рос. Федерации, Урал. федерал. ун-т. — Екатеринбург : Изд-во Урал. ун-та, 2017. — 139 с.
3. Родионов М.Г. Методики оценки качества предоставления государственных и муниципальных услуг // Вестник СИБИТа. 2018. №1 (25). С. 62 - 66.

*Горбачева Н.А.
студент кафедры «Экономическая информатика,
учет и коммерция»
Гомельский государственный университет
имени Франциска Скорины
Республика Беларусь, г. Гомель
Родионова Т.С.
старший преподаватель
Гомельский государственный университет
имени Франциска Скорины
Республика Беларусь, г. Гомель*

СОВЕРШЕНСТВОВАНИЕ СИСТЕМЫ БЕЗНАЛИЧНЫХ БАНКОВСКИХ РАСЧЁТОВ

Аннотация: в статье приведены основные направления развития системы безналичных банковских расчетов. Предложено расширение использования платежных гаджетов, а также введение в организацию бухгалтерского учета ежедневных балансов по безналичным расчетам. Разработан новый порядок проведения мгновенных платежей в банках.

Ключевые слова: банк, безналичные расчеты, ежедневный баланс, система мгновенных платежей.

*Gorbacheva N.A.
student of the department «Economic informatics,
accounting and commerce»
Gomel State University of Francisk Skorina
Republic of Belarus, Gomel
Rodionova T.S.
senior lecturer
Gomel State University of Francisk Skorina
Republic of Belarus, Gomel*

IMPROVEMENT OF THE CASHLESS PAYMENT SYSTEM IN THE BANK

Abstract: The article presents the main directions of development of the cashless payment system in the bank. The article proposes expanding the use of payment gadgets, as well as introducing daily balances for cashless payments into the organization of accounting. A new procedure for making instant payments in banks has been developed.

Keywords: bank, cashless payments, daily balance, instant payment system.

Важное место в проводимой работе по совершенствованию системы безналичных расчетов занимают выработка и осуществление мер по развитию системы безналичных расчетов физических лиц за товары (работы, услуги), то есть системы розничных платежей. Стратегическим направлением для банков является расширение использования банковских платежных карточек различных модификаций как наиболее перспективного платежного инструмента, а также развитие возможностей проведения расчетов с использованием смартфонов и других платежных гаджетов (браслеты, кольца и т. п.), что позволит в целом обеспечить достижение экономического эффекта и выгод для всех участников расчетов.

Также для банков целесообразно ввести в организацию бухгалтерского учета ежедневные балансы по расчетам платежными поручениями и требованиями, что позволит более быстро отслеживать суммы поступлений и расходов по счетам клиентов, облегчит аналитический учет движения средств и, тем самым, обеспечит повышение качества и оперативности получения аналитической информации о состоянии и тенденциях развития расчетов. Организация ежедневных балансов позволит осуществлять более быстрый и качественный анализ по квартальным отчетам, а также позволит отслеживать поступления расчетов по инкассо и аккредитиву.

В случае грамотно смоделированной группировки и распределении сумм поступлений на счета клиентов, организация ежедневного учета по платежным поручениям и требованиям не составит труда, но значительно облегчит ведение других квартальных и годовых отчетов.

Еще одним направлением развития организации безналичных расчетов в банках Республики Беларусь может стать совершенствование системы мгновенных платежей, являющейся современной формой решения вопросов по ускорению процессов совершения платежей, позволяющей максимально быстро (в режиме времени, приближенном к реальному) выполнить расчеты между конечными пользователями. «Мгновенный платеж» определяется как платеж, в котором передача платежного сообщения и переводимых средств получателю происходит в режиме реального времени или почти в режиме реального времени на основе 24/7 с соблюдением безотзывности платежа и обеспечением окончательности расчета.

С учетом Концепции создания сервиса по мгновенным платежам, разработанной Национальным банком Республики Беларусь [1], для банков рекомендуется усовершенствовать систему мгновенных платежей по следующей схеме, представленной на рисунке 1.



Рисунок 1 – Механизм усовершенствованной организации системы мгновенных платежей по схеме 24/7/365

Порядок организации предложенной системы мгновенных платежей представлен в таблице 1.

Таблица 1 – Усовершенствованный порядок проведения мгновенных платежей для клиентов банка

Параметры системы	Платеж «Клиент банка – клиенту банка»	Платеж «Клиент банка – клиенту другого банка»
Обеспечение платежа	Депозит в банке на оговоренную сумму	
Ограничения платежа	Оговоренный список получателей платежей	
Дополнительное обеспечение	—	Страховой депозит (предварительное финансирование) банка в Национальном банке Республики Беларусь
Механизм расчета	Автоматическая блокировка средств на депозите и мгновенный перевод средств с последующим их переводом и пополнением на следующий операционный день	

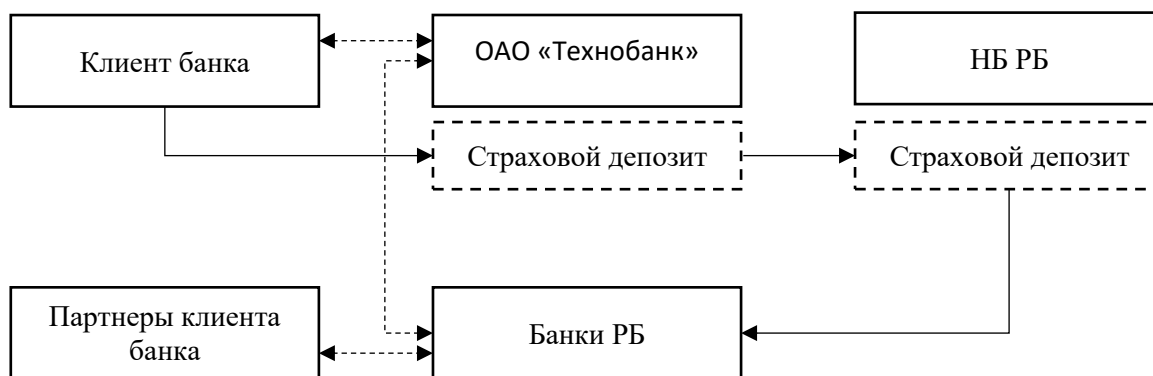
На сегодняшний день система платежей 24/7/365 внедрена с ограничением – необходимость обязательного наличия средств у клиента на текущем расчетном счете. Предлагается усовершенствовать данную систему путем создания «страхового депозита», который, помимо классических условий депозита, предлагаемого банком юридическим лицам, будет поддерживать также и функцию возможности его использования банком для обеспечения мгновенного платежа с последующим возвратом извлеченных из депозита средств на следующий операционный день, когда клиенту на расчетный счет поступят ожидаемые средства.

Обеспечение для своих клиентов возможности совершения платежа за счет создания страховых депозитов (по принципу предварительного

финансирования) на счетах в банке обеспечит не только повышение лояльности уже существующих клиентов и приток депозитных ресурсов в банк, но и за счет пока еще низкого уровня развития данной услуги обеспечит приток новых клиентов, так как данная услуга в корпоративном сегменте на сегодняшний день в силу стандартного окончания операционного дня в 15:00-16:00 является крайне востребованной и ожидаемой.

В целях совершенствования системы безналичных расчетов банкам рекомендовано:

– расширение использования банковских платежных карточек различных модификаций как наиболее перспективного платежного инструмента, а также развитие возможностей проведения расчетов с использованием смартфонов и других платежных гаджетов (браслеты, кольца и т.п.);

– ввести в организацию бухгалтерского учета ежедневные балансы по расчетам платежными поручениями и требованиями;

– совершенствование системы мгновенных платежей, являющейся современной формой решения вопросов по ускорению процессов совершения платежей, позволяющей максимально быстро (в режиме времени, приближенном к реальному) выполнять расчеты между конечными пользователями.

Использованные источники:

1 Концепция создания сервиса по мгновенным платежам, доступного в режиме 24/7/365: протокол заседания Правл. Нац. банка Респуб. Беларусь от 13.12.2017 №47/П [Электронный ресурс]. – Минск, 2020. – Режим доступа: <https://www.nbrb.by/payment/concept-instant-payment-service.pdf>. – Дата доступа: 05.12.2020.

*Горбулинская А.П.
студент магистратуры
научный руководитель: Гребнев Г.Д., к.э.н.
доцент
Оренбургский государственный университет*

СУЩНОСТЬ ПОНЯТИЯ ФИНАНСОВОЕ СОСТОЯНИЕ ОРГАНИЗАЦИИ

Аннотация: В статье рассмотрены определения понятия финансовое состояние организации. Представленные определения оценены с точки зрения полноты отражения в них основных характеристик финансов. Выявлено наиболее точное определение финансового состояния.

Ключевые слова: финансовое состояния, финансы.

*Gorbulinskaya A.P.
master student
Academic adviser: Grebnev G.D., PhD in Economics
Associate professor
Orenburg State University*

ESSENCE OF THE FINANCIAL STATE OF THE ORGANIZATION

Abstract: The article deals with the definitions of the concept of the financial condition of the organization. The presented definitions are assessed from the point of view of completeness of reflecting the main characteristics of finance. The most accurate definition of financial condition is revealed.

Key words: financial condition, finances.

В современной экономике оценка финансового состояния является одним из важнейших направлений экономического анализа деятельности хозяйствующих субъектов. Методики оценки достаточно подробно рассмотрены в экономической литературе, однако понятийный аппарат, которым оперируют авторы, имеет разночтения. В частности, само понятие финансовое состояние по-разному определяется учеными-экономистами, что вносит неясность в изучение теоретических аспектов применения методик. В связи с этим исследование сущности финансового состояния и выведения единого определения данного понятия является актуальной задачей.

Начиная исследование понятие финансовое состояние, необходимо обратиться к определению понятий «финансы» и «состояние», так как, по

сути, финансовое состояние организации – это состояние, в котором находятся ее финансы.

Финансы, согласно общепринятому определению, представляют собой систему экономических отношений, которые возникают в процессе формирования, распределения и использования фондов денежных средств. Следовательно, в определении финансового состояния должны быть отражены перечисленные выше характеристики финансов.

«Состояние – совокупность основных параметров и характеристик какого-либо объекта, явления или процесса в определенный момент (или интервал) времени» [7]. Значит, финансовое состояние должно быть определено как совокупность показателей.

Рассмотрим определения финансового состояния, предлагаемые авторами в своих работах (таблица 1).

Таблица 1 – Определения понятия финансовое состояние

Автор	Определения и особенности в трактовке автора
1	2
Абдукаримов И.Т.	«Финансовое состояние предприятия – это комплекс показателей, характеризующих наличие финансовых ресурсов по видам, уровень конкурентоспособности, финансовой устойчивости, способности выполнения обязательств перед государством и другими хозяйствующими субъектами» [1]
Гарнов А. П.	«Финансовое состояние – это совокупность показателей, отражающих наличие, размещение и использование его финансовых ресурсов, а также источников их формирования, которые определяют рыночную и финансовую устойчивость предприятия, его платежеспособность и ликвидность, деловую активность и эффективность» [2]
Герасименко Г. П., Маркарян Е. А.	«Финансовое состояние — совокупность показателей, отражающих способность предприятия погасить свои долговые обязательства» [3]
Ионова Ю. Г.	«Под финансовым состоянием понимается способность предприятия финансировать свою деятельность» [10]
Клишевич Н. Б.	«Под финансовым состоянием предприятия в аналитической теории и практике понимается степень его обеспеченности денежными средствами для осуществления текущей хозяйственной деятельности, а также дальнейшего производственного и социального развития» [9]
Ковалев В. В.	«Финансовое состояние – это совокупность показателей, отражающих наличие, размещение и использование финансовых ресурсов» [4]

Куприянова Л. М.	«Финансовое состояние коммерческой организации характеризуется обеспеченностью денежными средствами для ведения хозяйственной деятельности в условиях конкурентной среды» [5]
Любушин Н. П.	«Под финансовым состоянием понимается способность организации финансировать свою деятельность» [6]
Савицкая Г. В.	«Финансовое состояние – способность субъекта хозяйствования финансировать свою деятельность, постоянно поддерживать платежеспособность и инвестиционную привлекательность в границах допустимого риска» [8]

Рассмотрение представленных определений подтверждает, что между авторами нет единомыслия. Однако на основе сходства некоторых определений можно выделить основные подходы к пониманию сущности финансового состояния.

В рамках первого подхода финансовое состояние рассматривается как способность организации финансировать свою деятельность, что означает обеспечение целей функционирования организации источниками финансирования. Следовательно, в определении учитывается только одна составляющая финансов – формирование финансовых ресурсов, которая не раскрывает в полной мере сущность финансового состояния.

Второй подход – определение финансового состояния как степени обеспеченности организации денежными средствами. В данном определении также не учитываются все составляющие финансов, оно неполно и неточно отражает сущность финансового состояния.

Третий подход – определение финансового состояния как способности организации погасить долговые обязательства. Данное определение слишком узко, оно не отражает сущность финансового состояния в полной мере, не включает характеристики финансов.

В рамках четвертого подхода финансового состояния определяется как совокупность показателей, характеризующих различные его стороны. Из всех определений данного подхода наиболее точным и кратким является определение, сформулированной В. В. Ковалевым: «финансовое состояние – это совокупность показателей, отражающих наличие, размещение и использование финансовых ресурсов» [4].

Таким образом, на основе рассмотрения авторских определений понятия финансовое состояние и их оценки с точки зрения отражения основных характеристик финансов можно сделать вывод: финансовое состояние – это экономическое состояние организации, которое характеризуется системой показателей, позволяющих сделать вывод о результатах формирования, распределения и использования финансовых ресурсов. Понимание сущности финансового состояния позволит

обоснованно определять направления его исследования и делать корректные выводы по результатам анализа.

Использованные источники:

1. Абдукаримов И. Т., Беспалов М. В. Анализ финансового состояния и финансовых результатов предпринимательских структур: учеб. пособие. М.: ИНФРА-М, 2019. 214 с.
2. Анализ и диагностика финансово-хозяйственной деятельности предприятия: учебник / А. П. Гарнов [и др.]. М.: ИНФРА-М, 2018. 366 с.
3. Герасименко Г. П., Маркарьян Е. А. Финансовый анализ. М.: КноРус, 2011. 272 с.
4. Ковалев В. В. Анализ финансового состояния и прогнозирование банкротства. СПб.: Аудит Ажур, 1994. 163 с.
5. Куприянова Л. М. Финансовый анализ: учеб. пособие. М.: ИНФРА-М, 2020. 157 с.
6. Любушин Н. П. Экономический анализ: учебник. М. : ЮНИТИ-ДАНА, 2017. 575 с.
7. Новая философская энциклопедия в 4-х томах / В. С. Стёпин [и др.]. М.: Мысль, 2000. 2659 с.
8. Савицкая Г. В. Анализ хозяйственной деятельности: учеб. пособие. М.: ИНФРА-М, 2019. 284 с.
9. Экономический анализ: учеб. пособие / Н.Б. Клишевич [и др.]. М.: НИЦ ИНФРА-М, 2013. 192 с.
10. Экономический анализ: учебник / Ю. Г. Ионова [и др.]. М.: Московская финансово-промышленная академия, 2012. 432 с.

ПРИМЕНЕНИЕ CRM-МАРКЕТИНГА ДЛЯ ПРОДВИЖЕНИЯ БИЗНЕСА В СТОМАТОЛОГИИ

Аннотация: Опытный руководитель имеет представление о CRM-маркетинге, но далеко не все понимают пользу CRM-маркетинга. В связи с чем внедрение CRM-маркетинга в малый и средний бизнес не частое явление, хотя это сделает бизнес более выгодным и менее финансово-затратным. Владея огромным объемом информации о клиенте компании может построить стратегию для более высокой работы, которая относится к маркетингу, торговле и предоставлению услуг, повышению прибыли, но только тогда, когда руководитель понимает принцип работы CRM-маркетинга и пользуется всеми его преимуществами.

Ключевые слова: CRM, Маркетинг, UTM-метка, IDENT, колтрекинг

Grigoryan A.R.
student

Moscow University of finance and industry

APPLICATION OF CRM MARKETING FOR BUSINESS PROMOTION IN DENTISTRY

Abstract: An experienced manager has an idea about CRM marketing, but not everyone understands the benefits of CRM marketing. In this regard, the introduction of CRM marketing in small and medium-sized businesses is not a frequent phenomenon, although it will make the business more profitable and less financially costly. Having a huge amount of information about the client, the company can build a strategy for higher performance, which relates to marketing, trading and providing services, increasing profits, but only when the manager understands the principle of CRM marketing and enjoys all its advantages.

Keywords: CRM, Marketing, UTM-mark, IDENT, call-tracking.

В статье рассмотрено CRM-внедрение в стоматологический бизнес, новизна и актуальность работы в том, что подобных работ, рассматривающих столь узкий профиль, как стоматологический бизнес нет, хотя на сегодняшний день — это один из самых перспективных и ведущих бизнесов. В связи с этим много бизнесменов скупают клиники и потом остаются в больших убытках.

В чем же причина? Многие не понимают, что такой специфический и конкурентный бизнес, как стоматология, включает в себя не только наличие денег, но и подбор высококвалифицированных кадров, налаженная работа с пациентами, адаптированная бизнес-стратегия, и самое главное стабильность в отделе кадров. В связи с этим, в статье описан такой CRM-инструмент, как IDENT-программное обеспечение работы стоматологической клиники. Он направлен на: -оценивание эффективности вашей рекламы и ее контроль; -контроль качества общения административного персонала с пациентами (таким образом можно удержать пациентов, чтобы они не отсеялись), сюда входят смс-оповещения, обращения, заявки и звонки; -автоматическая работа с агрегаторами, лэндингами; -обнаружение большего количества общих точек соприкосновения с клиентами (управление базой данных); -работа с документацией; -интеграция с IP-телефонией, колл-центром.

Функционал у IDENT-маркетинга достаточно широкий, поэтому данная система удобна не только администраторам, но и руководителю. Как же потенциальные пациенты могут узнать о стоматологии? В 21 веке многие просто ищут клиники или услуг через социальные сети, по статистическим данным сегодня уже в Москве и Санкт-Петербурге заявки из социальных сетей составляют до 10% всего первичного трафика, и в регионах эти показатели тоже растут. Сам процесс привлечения пациентов с помощью разных рекламных каналов описывается по типу воронки. Человек размещает информацию о клинике на различных источниках, после чего у людей появляется спрос к вашим услугам и происходит поток звонков и сообщений с вопросами.

Во время общения с администратором клиники некоторая часть людей отсеивается. Из-за чего пациенты отсеиваются? Потенциальному клиенту может показаться, что у вас дорого, ему далеко ехать или у ваших конкурентов более выгодные условия. Важно, чтобы на факторы, на которые вы заранее не можете повлиять, не появлялись ошибки: неправильный текст рекламы, неполное предоставление информации администраторам, nepозволительное поведения врача во время первого приема и тд.

Руководителю, чтобы понять эффективность своих вложений в рекламу, необходимо знать от каких каналов продвижения лучше отказаться, а в какие больше вкладывать, для этого необходимо анализировать все-звонки, заявки с сайта и лендингов, сообщения из онлайн-чатов и социальных сетей. Это даст возможность определить:

- целевые ли пациенты приходят к вам из разных рекламных каналов;
- что больше интересует пациентов;
- предоставляете ли вы заинтересованным в лечении всю необходимую информацию.

Сделав выводы, можно скорректировать рекламную стратегию, выработать готовые скрипты разговора с клиентами для администраторов и по итогу, можно получить довольных клиентов и существенный рост прибыли. Программа IDENT отчасти решает эту проблему тоже, что может сократить время работы и повысить эффективность, в программе есть понятие «Обращение». В течении суток человек может написать на различные социальные сети, далее позвонить и записаться на прием. Или же сначала позвонить и не записаться, а потом зайти в клинику по пути домой с работы и тогда уже, назначат прием, а возможно, уходит, при этом не получив ответа на свои вопросы. В каждом из примеров, все коммуникации клиента с клиникой в рамках одного дня можно объединить-в IDENT называют «обращение».

С функционалом IDENT можно получить много уникальных обращений и не просто увидеть откуда приходят люди, но и понять-пациент, пришел из какого рекламного канала и что приносит больше денег каналу. Можно проследить «путь» пациентов: обращение-запись на прием-посещение врача-дальнейшее лечение.

Инструменты, которые помогают собирать информацию, чтобы определить из какого рекламного канала к вам в клинику пришел клиент. Использование статического коллтрекинга (call-tracking, отслеживание звонков): - на каждом ресурсе, на котором размещена информация о вас показывает свой уникальный номер; -руководитель может определить самые важные для вас рекламные каналы (вконтакте, Яндексдирект, сервисы, баннеры и т.д.). Использование динамического коллтрекинга (актуально для тех, кто активно использует контекстную рекламу). Этот способ позволяют получить у звонков UTM-метки с точностью до конкретного баннера, ролика, статьи определить, откуда человек совершает звонок.

Сайты-агрегаторы. Размещение информации о своей компании на подобных сайтах-тренд, который невозможно игнорировать, особенно если у вас нет громкого и уникального имени. Конкуренция на рынке стоматологических услуг огромная. В условиях, когда огромная часть трафика забирает на себя сайт-агрегатор. IDENT интегрирует со значимыми агрегаторами по медицинской тематике: Продокторов, Сберздоровье (ранее DocDoc, Напоправку). На все сервисы выгружается расписание из IDENT, человек ищет какую-то услугу-попадает на один из этих сайтов-находит там вас-видит, что вы ему подходите. Дальнейший процесс: потенциальный клиент в специальной форме оставляет свое имя и контрактные данные-администратору в IDENT приходит уведомление с именем и телефоном оставившего заявку, а также с указанием времени, в которое человек хотел бы прийти, и фамилии врача-нужно обработать эту заявку и записать пациента на прием.

Благодаря CRM-маркетингу появилась возможность оценить эффективность рекламы и контролировать качество общения администраторов с пациентами-звонки, заявки, обращения в социальных сетях. Основные плюсы использования CRM-маркетинга внутри стоматологии: -повышение объема прибыли; -увеличение лояльности пациентов; -масштабирование клиентской базы; -повышение доли рынка; -уменьшение времени, которое затрачивается на проведение операций, связанных с обслуживанием пациентов; -снижение расходов.

Внедрение таких систем и в другие учреждения сильно снизит затраты и время на обработку данных, а также подготовку различных документаций, даст возможность учреждению обеспечить оперативность обработки информации, следовательно сможет решить важную задачу, которая ведет к основной цели-повышение прибыли и улучшению собственного бизнеса, так как CRM-отличный помощник в деле удержания и повышения лояльности существующих пациентов стоматологических клиник.

Использованные источники:

1. Гринберг Пол CRM со скоростью света. Привлечение и удержание клиентов в реальном времени через Интернет; Символ-Плюс - , 2006. - 530
2. Кинзябулатов Р.Х. CRM. Подробно и по делу.1-ая редакция.2016г.,170
3. Хойер Джо Война за клиента. Лояльность раз и навсегда; Попурри - Москва, 2010. – 112 С

*Гусев А.В., к.т.н.
начальник сектора
АО НИИ ТП
Россия, Москва*

АЛГОРИТМЫ ИНДЕКСИРОВАНИЯ ГЕОПРОСТРАНСТВЕННЫХ ДАННЫХ В СИСТЕМАХ КОНТРОЛЯ ЗА МОБИЛЬНЫМИ СРЕДСТВАМИ

Аннотация: Рассмотрено применение методов статистического анализа в алгоритмах построения структур индексирования геопространственных данных. Приведены результаты численных экспериментов.

Ключевые слова: база данных, ГИС, системы мониторинга

*Gusev AV., Ph. D.
Head of the Sector
JSC NII TP
Russia, Moscow*

ALGORITHMS FOR INDEXING GEOSPATIAL DATA IN MOBILE VEHICLE MONITORING SYSTEMS

Abstract: The application of statistical analysis methods in algorithms for constructing geospatial data indexing structures is considered. The results of numerical experiments are presented.

Keywords: Database, GIS, monitoring systems

Введение. Данные о местоположении объектов реального мира играют важную роль во многих областях, например таких, как системы контроля и управления общественным транспортом.

Во многих городах России используется спутниковая система контроля за транспортом, обеспечивающая безопасность и четкость движения общественного транспорта. Информация о местоположении мобильных средств в реальном времени может быть получена с помощью различных программно-аппаратных комплексов, основанных на использовании географических информационных систем (ГИС). Эти системы обеспечивают доступ к данным глобального позиционирования, выполняется обработка, визуализация и индексирование такого вида информации. В исследовании не рассматриваются показатели скорости и направления движения.

На мобильном объекте устанавливается приемо-передающее устройство, которое обеспечивает передачу координат о местоположении на сервер, в том числе и сервер базы данных.

По степени распределённости информационная система может быть:

- ✓ настольной, или локальной, в которой все компоненты (БД, СУБД, клиентские приложения) находятся на одном компьютере;
- ✓ распределённой, в которых компоненты распределены по нескольким компьютерам.

Распределённые, в свою очередь, разделяют:

- ✓ на файл-серверные (системы с архитектурой «файл-сервер»);
- ✓ клиент-серверные (системы с архитектурой «клиент-сервер»).

В файл-серверных системах база данных находится на файловом сервере, а СУБД и клиентские приложения находятся на рабочих станциях.

В клиент-серверных системах база данных и СУБД находятся на сервере, а на рабочих станциях находятся клиентские приложения.

Применение алгоритмов индексирования не зависит от распределённости и позволяет снизить время доступа к накапливаемым данным. Типовыми запросами могут быть:

- ✓ определение положения мобильного объекта в заданный момент времени
- ✓ предоставить хронологию передвижения мобильных средства
- ✓ определение времени через которое транспортное средство достигнет заданные координаты.

Представлен метод индексирования, основан на использовании робастного метода статистического анализа.

Теоретический анализ. Эффективный доступ к данным является одной из важнейших задач, решаемых СУБД. Обычно это достигается использованием вспомогательной структуры, сокращающей число обращений к вторичной памяти.

Индекс позволяет уменьшить число дисковых операций, необходимых для считывания данных с диска. Методами доступа называют структуру индексного файла и способы работы с ней. Обычные способы индексирования записей в таблице строятся по статическим полям или по полям, которые редко изменяются. Изменяются такие структуры не часто, и поэтому скорость изменения не критична.

Поскольку в нашем случае характеристики пространственных объектов не являются статическими, а часто изменяются с течением времени, то для поддержания эффективности структуры индексов должны изменяться также часто и быстро.

Наиболее известными способами индексирования географических объектов являются R- и R*-деревья. В этих сбалансированных по высоте деревьях листовые узлы содержат ссылки на записи таблицы. Узлы

соответствуют дисковым страницам, если индексная структура находится на жёстком диске.

Описанный выше способ индексирования пространственных объектов – R-дерево – является популярным методом для индексирования прямоугольников. Он основан на эвристической оптимизации площади охватывающих прямоугольников в каждом узле. В классическом R-дереве вся оптимизация сводится к уменьшению площади охватывающих прямоугольников. После проведения экспериментов на стандартизированной испытательной модели с большим количеством данных, запросов и операций было спроектировано R*-дерево. С этой структурой индексирования был внедрён комбинированный метод оптимизации, зависящий от площади, периметра и пересечения прямоугольника. Подвижность индексируемых объектов требует частого изменения индексной структуры. Для добавления новой записи в уже заполненный элемент R-дерева, содержащий N записей, необходимо разделить группу из $(N+1)$ записи на два элемента R-дерева. Такой алгоритм применяется при удалении ненужной записи, обновлении структуры. Этот алгоритм особенно важен, так как может сильно замедлить работу алгоритмов поиска. Формирование элемента без учёта критериев оптимальности построения структуры приводит прежде всего к увеличению времени работы алгоритма поиска, а следовательно, к медленному выполнению остальных алгоритмов. Тесная связь между геометрией и статистикой обусловлена тем, что многомерные статистические данные можно рассматривать как точки в евклидовом пространстве. В некоторых задачах статистики построение выпуклой оболочки является основным моментом. Так как среднее значение выборки является несмещённой оценкой для среднего значения, то оно очень чувствительно к выбросам – наблюдениям, существенно выпадающим из основной массы. Желательно уменьшить влияние, оказываемое такими выбросами, так как они часто предоставляют неверные данные, которые могут внести ошибки. Соответствующее свойство, которому должна удовлетворять хорошая оценка, называется робастностью (устойчивостью), что означает нечувствительность к отклонениям от предполагаемого распределения. Сравнение различных методов и алгоритмов индексирования позволило выделить наиболее предпочтительные алгоритмы, которые были реализованы в slR -дереве, т.е. пространственного индекса, основанного на методах, приведённых в данной работе. На одинаковых исходных данных вычислительная сложность алгоритмов slR -дерева содержит меньше операций чем в алгоритмах R-дерева. Таким образом, для парка общественного транспорта составляющего 7500 автомобилей, точность определения местоположения составит 10 м вместо 20 м при движении со скоростью 30 км/ч. Качество структур можно определить с помощью геометрических свойств листовых элементов. Для транспортной сети

рассматриваемая структура имеет больший суммарный периметр листовых элементов.

Заключение. Результаты экспериментов свидетельствуют о возможности применения робастных методов в эвристических алгоритмах построения индексных структур. На тестовых данных было показано превосходство разработанного комбинированного метода классификации над методом классификации k -средних при использовании сравниваемых в алгоритмах построения структуры R -дерева.

Использованные источники:

1. Айвазян С.А., Бухштабер В.М., Енюков И.С., Мешалкин Л.Д. Прикладная статистика: Классификация и снижение размерности. Справочное издание. -М. : Финансы и статистика, 1989. - С. 18-46.
2. Препарата Ф., Шеймос М. Вычислительная геометрия: Введение. М.: Мир, 1989.
3. Гусев А.В. Использование эвристических методов кластеризации в пространственных методах доступа. Информационные технологии. 2006. № 12.

*Джаксымуратов К., к-г.м.н.
преподаватель
НФ НГГИ
Ембергенов Н., к.г.н.
преподаватель
КГУ
Айтмуратов А., магистр
НГПИ*

ИССЛЕДОВАНИЯ КЛИМАТО - МЕЛИОРАТИВНЫХ УСЛОВИИ ПРИАРАЛЬЯ

Аннотация. Формирования климата в Приаралье происходит в основном под влиянием континентальных сибирских и арктических воздушных масс с неустойчивыми климатическими показателями во времени. Изменение условий грунтовых вод Приаралья зависит также и от степени мелиорации земель. Для ликвидации причин засоления почв, кроме вышеизложенных, необходим дренаж грунтовых вод с обязательным отводом за пределы орошаемой территории (в Аральское море, Сарыкамышскую впадину).

Ключевые слова. Климат, воздушная масса, температуры воздуха, грунтовые воды, Приаралья, минерализация, орошения, р.Амударья, мелиорация, почво-грунты, засоления почвы, растительный покров.

*Djaksimuratov K., PhD
Lecturer
Nukus branch of Navoiy State Mining Institute
Embergenov N., PhD
Lecturer
Karakalpak State University
Aytmuratov A., master
of Nukus State Pedagogical Institute*

RESEARCH OF CLIMATE - MELIORATION CONDITIONS OF THE ARAL REGION

Abstract. The formation of the climate in the Aral Sea region occurs mainly under the influence of continental Siberian and Arctic air masses with unstable climatic indicators over time. Changes in the conditions of groundwater in the Aral Sea region also depend on the degree of land melioration. To eliminate the causes of soil salinization, in addition to the above, groundwater drainage is

required with the obligatory drainage outside the irrigated territory (into the Aral Sea, Sarikamish depression).

Key words. Climate, air mass, air temperatures, ground waters, Aral Sea region, mineralization, irrigation, Amudarya river, reclamation, soil-grounds, soil salinization, vegetation cover.

Климат Приаралья, формирующийся под влиянием континентальных сибирских и арктических воздушных масс, резко континентальный, с большими годовыми и суточными амплитудами температуры воздуха, неустойчивыми климатическими показателями во времени [1]. В регионе осадки сократились в несколько раз и их величина в среднем составляет 150-200 мм со значительной неравномерностью по сезонам. Отмечается высокая испаряемость (до 1700 мм в год) при уменьшении влажности воздуха на 10% [4].

В связи с этим, учитывая важную роль климата в развитии процессов современного переувлажнения и засоления почв, а также появление в последнее время большого количества работ, касающихся существенных климатических изменений, инициирующих изменения в динамике уровня грунтовых вод и в преобразовании почвенного и растительного покровов провести исследования с целью установления наличие возможных климатических изменений в регионе Приаралья [5].

Изменение условий грунтовых вод Приаралья зависит также и от степени мелиорации. Орошаемая площадь в низовье р.Амударьи в последние годы составляет 498,76 тыс.га, а водоподача на поля около 5556,30 млн. м³. Объектом мелиорации являются аллювиальные почво-грунты и подстилающие их мелкозернистые пески четвертичного возраста мощностью 50 м, до регионального водоупора сложенного глинами верхнего мела и верхне-среднего эоцена. [3].

В результате мелиоративных работ минерализация воды в р.Амударья (период промывных поливов) достигает до 3,7 г/л, которая в свою очередь влияет на состояние подземных вод. На массивах хлопкового комплекса, максимальный уровень грунтовых вод отмечается в июле-августе месяце на 0,95-2,3 м от поверхности земли в период вегетационных поливов хлопчатника. На промывочные поливы подается вода с минерализацией 1,2-2,7 г/л, эти поливы не дают ожидаемого промывочного эффекта. Интенсивность соленакоплений на 1996 год составляет 240 тыс.тн/год, что на 9,9 тыс.тн меньше по сравнению с 1990 годом. Почво-грунты зоны аэрации до глубины 3,2 м чрезвычайно сильно засолены, на глубине 2,3 м сильно засолены, ниже залегают грунты слабо засоленные.

На массивах рисосеяния изменение режима грунтовых вод имеет определенную периодичность и стабильность. Начиная с 1990 г. среднегодовые уровни грунтовых вод имеют тенденцию повышения со средней скоростью 0,05 м /год [2].

Минерализация грунтовых вод на массивах рисосеяния составляет 1,5-2,5 г/л. В многолетнем разрезе влияние орошения происходило до глубины 7-8 м, но за последние годы увеличение минерализации отмечается до 20 м.

Существующая сеть коллекторов не обеспечивает полного отвода соленых дренажных вод, сбрасываемых в понижения рельефа за пределы освоенной зоны, способствуя заболачиванию и засолению площадей.

Анализируя материалы комплексных гидрогеологических и инженерно-геологических съемок по влиянию орошения на состояние грунтовых вод можно говорить, что:

1. Необходимо усилить работы по улучшению технического состояния существующей коллекторно-дренажной сети. По почвенно-гидрогеологическим условиям отдельных земель требуется проводить агротехнические мероприятия по борьбе с засолением почв. Соблюдать плановый режим орошения, а также перенести большую часть промывных поливов с весны на осень.

2. Мелиорация засоленных и заболоченных земель должна заключаться в снижении уровня грунтовых вод, рассолении грунтов. Дальнейшие исследования необходимо провести для выбора оптимальной конструкции вертикальных и горизонтальных дренажей. Рекомендуется глубина дренажных скважин 30-35 м и горизонтальный дренаж.

3. Для ликвидации причин засоления почв, кроме вышеизложенных, необходим дренаж грунтовых вод с обязательным отводом за пределы орошаемой территории (в Аральское море, Сарыкамышскую впадину). Для обоснования выбора дренажных систем необходима постановка соответствующих гидрогеологических исследований. Часть дренажных вод (с минерализацией до 5 г/л) можно использовать для орошения с предварительным смешиванием с пресными грунтовыми водами.

Использованные источники:

1. Жапарханов С.Ж., Джаксымуратов К.М. Гидрогеоэкология Приаралья. Межвузовский сб. научных трудов "Рациональное использование подземных вод Казахстана и их охрана", А-А, 1994. С.76-88.
2. Крылов м.М. Основы мелиоративной гидрогеологии Узбекистана. Ташкент, 1977. 248 с.
3. Лебедев А.Ф. Почвенные и грунтовые воды. М: Изд. АН СССР, 1936. 316 с.
4. Sultashova O., Khudaybergenov Ya., Oteuliev M., Reimov M. Modeling of Temperature Mode of the Soil. International Journal of Psychosocial Rehabilitation. ISSN:1475-7192. Vol. 24, Iss. 4, April 2020, Pp. 6057-6068. DOI: [10.37200/IJPR/V24I4/PR2020416](https://doi.org/10.37200/IJPR/V24I4/PR2020416)
5. Nauruzbaeva, G. T.; Embergenov, N. J.; and Oteuliev, M. O. (2018) "Study of the contemporary state of the environment and the status of population health in the conditions of Southern Aral Region," Karakalpak Scientific Journal: Vol. 2,

Iss. 1, Article 11. DOI: ISSN 2181-9203 Available:
<https://uzjournals.edu.uz/karsu/vol2/iss1/11>

*Джаксымуратов К., к-г.м.н.
преподаватель
НФ НГГИ
Узбекистан, Нукус
Отеулиев М.
докторант
КГУ
Узбекистан, Нукус
Айтмуратов А.
студент магистратуры
НГПИ
Узбекистан, Нукус
Бекмуратов А.
студент магистратуры
ТГТУ
Узбекистан, Ташкент*

**ИССЛЕДОВАНИЕ РЕЖИМА, РЕСУРСОВ И ИСПОЛЬЗОВАНИЕ
ПОДЗЕМНЫХ ВОД ЮЖНОГО ПРИАРАЛЬЯ (РЕСПУБЛИКА
КАРАКАЛПАКСТАН)**

Аннотация. В статье представлены результаты полевых и научных исследований по режиму, ресурсы и использование подземных вод Южного Приаралья (Республика Каракалпакстан). Гидрогеологические условия водоносных горизонтов и комплексов изменяется от геологических и инженерно-геологической деятельности человека (поливы, дренаж, сброс избыточных ирригационных вод в местные понижения рельефа и т.д.), придающая специфические черты развитию современных гидрогеологических процессов в пределах всего Приаралья.

Ключевые слова: уровень подземных вод, пресные линзы, режимные наблюдения, запасы подземных вод, ресурсы подземных вод, гидрогеологические исследования, солоноватые воды, водозабор.

*Djaksimuratov K., PhD.
Nukus branch of Navoiy State Mining Institute
Uzbekistan, Nukus
Oteuliev M.O.
Doctoral Candidate
Karakalpak State University
Uzbekistan, Nukus
Aytmuratov A.*

*master student
of Nukus State Pedagogical Institute
Uzbekistan, Nukus
Bekmuratov A.
master student
of Tashkent State Technical University
Uzbekistan, Nukus*

**RESEARCH OF REGIME, RESOURCES AND USE OF
UNDERGROUND WATER OF THE SOUTHERN ARAL SEA REGION
(REPUBLIC OF KARAKALPAKSTAN)**

Annotation. The article presents the results of field and scientific research on the regime, resources and use of groundwater in the Southern Aral Sea region (Republic of Karakalpakstan). The hydrogeological conditions of aquifers and complexes change from the geological and engineering-geological human activity (irrigation, drainage, discharge of excess irrigation water into local relief depressions, etc.), which gives specific features to the development of modern hydrogeological processes in the entire range of Southern Aral Sea Region.

Key words: groundwater level, fresh lenses, routine observations, groundwater reserves, groundwater resources, hydrogeological research, brackish waters, water intake.

Формирование запасов подземных вод Южного Приаралья, развитых в осадочной толще мезо-кайнозойских отложений и их солевого состава сложный процесс. Вода, будучи самым распространенным, подвижным и активным компонентом природной среды участвует во всех геологических процессах и зависит от геохимической и гидродинамической обстановки. Геологическая история развития предопределяет гидрогеологические условия региона, тем самым режим и ресурсы подземных вод [4].

Громадное влияние на гидрогеологические условия этих водоносных горизонтов и комплексов накладывает и инженерно-геологическая деятельность человека (поливы, дренаж, сброс избыточных ирригационных вод в местные понижения рельефа и т.д.), придающая специфические черты развитию современных гидрогеологических процессов в пределах всего Приаралья [1].

В Южном Приаралье запасы пресных подземных вод ограничены и наблюдается острая нехватка качественной питьевой воды. Единственным источником водоснабжения региона служат приканальные линзы грунтовых вод, приуроченные к песчаным отложениям вдоль р.Амударьи и оросительных каналов (таблица 1.). В данное время на действующих водозаборах изучаемой территории, возникла необходимость защиты

эксплуатируемых горизонтов от истощения и загрязнения путем искусственного вмешательства, применив метод магазинирования и опреснения линз грунтовых вод.

Таблица 1. Запасы подземных вод

Категория запасов	Количество, м ³ /сут			Разведанность запасов	Метод расчета граничных условий
	Паводок	Межень	Среднег одовой		
Водозабор Акмангит					
А	3974,4	2073,6	2707,2	Запасы установлены опытным путем	Совместное применение гидравлического и гидродинамических методов
В	3456	2073,6	2534,4	Запасы установлены расчетным путем	
С ₁	3110,4	2073,6	1036,8		
А+В+С ₁	10540,8	4145,2	6278,4		

Метод искусственного восполнения запасов подземных вод (ИВЗПВ) применяется на действующих водозаборах в случаях, когда пресные емкостные запасы водоносного горизонта в процессе эксплуатации истощены и не удовлетворяют заявленной потребности.

В аридных условиях - это единственный метод сохранения пресных водоносных горизонтов (линз), увеличения их емкостных запасов с расширением полезной площади, при естественном самоочищении воды от загрязнителей, и, тем самым, позволит обеспечить потребности населения круглогодично в питьевой воде. На основных действующих водозаборах, приуроченных к русловым и аллювиальным пескам, развитых вдоль р.Амударья, каналов Октябрь-Арна, Кегейли и Куванышджарма, применен метод искусственного восполнения и опреснения грунтовых вод и подсчитаны запасы [3,5].

Вдоль магистральных каналов и древних русел протоков (Шортанбай, Саманбай) р.Амударьи, пески содержат пресные и слабосоленоватые воды (с расходом потока 216 л/с), которые могут быть использованы на орошение, для технических целей и, частично, для водоснабжения населенных пунктов. По данным Каракалпакской режимной станции, 20-30% оросительных вод идет на пополнение первого от поверхности водоносного горизонта (грунтовые воды), и обуславливает низкую минерализацию. Ежегодные фильтрационные потери с орошаемых площадей в среднем составляют 10 м³ воды с 1 км², а на остальные статьи баланса: инфильтрация атмосферных осадков 3-7% годовой суммы (при среднемноголетней величине атмосферных осадков равной 100 мм), приток из регионального потока около 1% из приходной статьи баланса.

В связи с загрязнением вод поверхностных водотоков в Приаралье, одним из перспективных источников питьевого водоснабжения как сказано выше, могут служить только линзы пресных грунтовых вод. Они приурочены к серым мелкозернистым пескам Амударьинского и Сарыкамышского циклов и расположены вдоль крупных каналов: Кызкеткен, Куванышджарма, Кегейли, Казакьяб и др., и лишь Нукуская линза пресных вод приурочена к пескам современного, пескам и песчаникам туронского возрастов. Формирование линз происходит за счет фильтрационных потерь каналов и р.Амударьи на участках, где поверхностные водотоки вскрывают русловые пески четвертичных отложений. Фильтрационные потери поверхностных водотоков составляют 46-47 л/с на 1 м² его длины.

Средняя мощность пресных приканальных линз 25-30 м, ширина от 1000 до 3000 м. В последние годы минерализация воды в р.Амударья, а, соответственно, и в каналах, на протяжении паводкового периода превышает 1,0 г/л. Вследствие этого меняется гидрохимическая обстановка в зоне влияния этих водотоков. В настоящее время на основе гидрогеологических исследований выяснены влияния этих процессов на гидрогеологические условия территорий, прилегающей к р.Амударье и оросительным каналам, выявлены перспективные приканальные линзы пресных вод для применения метода магазинирования и опреснения подземных вод по централизованному водоснабжению населенных пунктов. [2].

Суммарная длина всех выявленных и детально разведанных участков линз пресных грунтовых и вод, пригодных для питьевого водоснабжения по республике Каракалпакстан, составляет около 30 км. С каждого километра длины линзы по аналогии разведанных запасов категории А+В+С₁, можно получить около 12 л/с пресной воды.

Напорные, самоизливающиеся воды турон-нижнесенонского водоносного комплекса используются для водопоя скота. Но вследствие того, что многие скважины не оборудованы крановыми устройствами, часть этих вод теряется бесполезно, вызывая при этом заболачивание прилегающих понижений рельефа. [1].

В целом же, учитывая постоянный рост минерализации и степень загрязнения поверхностных водотоков, наиболее перспективным источником водоснабжения следует считать искусственное магазинирование поверхностного стока в те периоды, когда поверхностные воды соответствуют требованиям ГОСТа, предъявленным к питьевой воде. В периоды же, когда вода в поверхностных водотоках имеет минерализацию более 1,0 г/л, искусственно сформированные линзы должны ограждаться от возможности подпитывания последней.

Использованные источники:

1. Акрамов А.А. Искусственное формирование и пополнение запасов прирусловых линз пресных вод. ФАН: 1988, Ташкент. 195 с.
2. Ахмедсафин У.М., Сыдыков Ж.С., Шапиро С.М и др. Подземный водный и солевой сток в бассейне Аральского моря, "Наука": Каз, А-А. 1983. 159 с.
3. Жапарханов С.Ж., Джаксымуратов К.М. Искусственное опреснение линз солоноватых подземных вод в Приаралье. Материалы научной и учебно-методической конференции посвященной 60-летию кафедры гидрогеологии и инженерной геологии КазПТИ, А-А, 1992. С.133-134.
4. Nauruzbaeva, G. T., Embergenov, N. J, Oteuliev, M. O. (2018) "Study Of The Contemporary State Of The Environment And The Status Of Population Health In The Conditions Of Southern Aral Region, Karakalpak Scientific Journal. Vol. 2, Iss. 1. 2018, -С. 29-31
5. Embergenov N.J., Oteuliev M.O., Karimbaev K., Madaminov X.R. The Importance Of Mineral Raw Material Resources In The Organization And Placement Of Industrial Sectors In The Republic Of Karakalpakstan. "Экономика и социум" №10(77) 2020, -С. 59-62.

*Дружинина А.А.
студент
Ермаков Б.А., к.м.н.
доцент
СГУ
Сочи*

СОВРЕМЕННЫЕ МЕТОДЫ И ТЕХНОЛОГИИ ПРОДВИЖЕНИЯ ТУРИСТИЧЕСКИХ УСЛУГ В ИНТЕРНЕТ-ПРОСТРАНСТВЕ

Аннотация: В статье говорится о развитии туристской индустрии. Она требует от участников рынка соответствующего уровня развития, способствующего сохранению конкурентоспособности участников. В данной работе хотелось бы затронуть такой важный момент, как продвижение туристских услуг. Без рассмотрения данного вопроса трудно выявить, что такое туристский продукт, каковы непосредственно его особенности, а также особенности продвижения на рынке.

Ключевые слова: туристская индустрия, развитие, интернет-технологии, продвижение.

*Druzhinin A.A.
student
Ermakov B.A., Candidate of Medical Sciences
Associate Professor
SSU
Sochi*

MODERN METHODS AND TECHNOLOGIES OF PROMOTION OF TOURIST SERVICES IN THE INTERNET SPACE

Abstract: The article talks about the development of the tourism industry. It requires market participants to have an appropriate level of development that will help maintain the competitiveness of participants. In this work, I would like to touch upon such an important point as the promotion of tourist services. Without considering this issue, it is difficult to identify what a tourist product is, what are its features, as well as the features of promotion on the market.

Keywords: tourism industry, development, internet technologies, promotion.

На данный момент туризм является показателем становления цивилизации, методом познания окружающей действительности, способом повышения культурного значения и восстановления здоровья людей.

Важно знать, что на сегодняшний день туризм является неотъемлемой частью нашей жизни. Туризм это одно из развивающихся направлений нашей страны. В данном разделе, при изучении современных методов и технологий продвижения экскурсионных услуг, термин «туристический продукт» будем применять равноценно термину «экскурсионные услуги».

Туристический продукт — это любая услуга входящая в тур и удовлетворяющая потребность туриста во время путешествий и подлежащая оплате со стороны потребителя.

Продвижение туристического продукта - является самой главной задачей на рынке туризма, а целью является спрос на турпродукт. Стоимость на продвижение увеличивается, и автоматически становится одним из центральных пунктов стратегии. Из этого следует, что рынок рекламы развивается и помогает привлекать клиентов, а также заинтересовывать их.

Крупные туристические компании, как правило, осуществляют регулярное продвижение своих товаров на рынок, а также рекомендации по наиболее эффективным методам рекламы.

К не рекламным методам продвижения туристского продукта относятся:

- 1) личные (персональные) продажи, которые осуществляются через агента
- 2) прямая рассылка информации (поддерживание устойчивой клиентуры, до которой доводится информация о конкретном туре и прочее)
- 3) прямой маркетинг (телефонные продажи, напоминание по смс, почтовая рассылка)
- 4) стимулирование сбыта – (скидки, конкурсы и розыгрыши призов для покупателей туров, бонусы, а также небольшие подарки от турфирмы, это может быть ручка, блокнот, кружка)
- 5) пропаганда или организация паблик рилейшнз – является косвенным предложением (организация культурных мероприятий, где распространяется расширенная информация о турах компании, куда приглашаются представители средств массовой информации).

Важной ролью в продвижении туристского продукта является стимулирование потребителей. Основными задачами стимулирования потребителей являются: поощрение большего потребления предлагаемых туров или отдельных услуг, причина для туристов к покупке услуг, которыми они не пользовались ранее.

В программе продвижения должны быть различные методы. Важна эффективность каждого из методов.

1. Реклама в СМИ: ТВ, радио, газеты, журналы. Она дает нам возможность сообщить информацию большой аудитории. Газета по сравнению с другими средствами рекламы менее затратная и часто обновляется, имея широкую аудиторию.

2. Каталоги, брошюры, проспекты.

В каталогах путешествий есть важная и нужна информация для туристов. Они могут применяться как справочные пособия и описания туристских товаров и услуг, иллюстрации, программы туров, отели, гостиницы, мероприятия и экскурсии, транспортные услуги и т. п.

Брошюры и проспекты будут менее обширны, чем каталоги, но их производство менее трудно и дешево. Обычно брошюра или проспект посвящаются только одной поездке, при этом там будет много рассказано о данном маршруте или услуге.

3. Уличная реклама: стационарная и транзитная (плакаты, щиты, реклама на транспорте). Как и для любой рекламы больше всего важно месторасположения, важно знать проходимость людей в этом месте, желательно, чтобы это был центр города. Конечно же, чаще всего эта реклама передается через картинки и является дополнением к рекламе в СМИ. Суть такой рекламы является напоминание.

4. Письма-продажи: у туристической фирмы имеется в наличии список постоянных клиентов, которым и отправляются письма, которые информируют о новых турах, услугах, скидках.

5. Реклама в торговой точке: реклама на витрине павильона или на стенах, сувениры и плакаты в офисе турфирмы. Клиент сталкивается с такой рекламой, когда он находится еще в процессе принятия решения. И задачей такой рекламы является – напомнить клиентам о том, что они уже сталкивались с этой рекламой раньше в средствах массовой информации.

Таким образом, каждый метод рекламы имеет свои преимущества и недостатки. Реклама должна быть правильно направлена на определенный сегмент рынка, ведь каждая турфирма заранее выбирает форму отношений со своим потребителем.

Использованные источники:

1. Веткин В.А. Технология создания туристского продукта: учебное пособие – М.: Гросс-Медиа, Росбук, 2016. – 200 с.
2. Дурович А.П. Организация туризма. Учебное пособие. – СПб: Питер. 2016. – 300с.
3. Ильина Е.Н. Туроперейтинг: организация деятельности: Учебник. – М.: Финансы и статистика, сайт. [Электронный документ] URL <https://eknigi.org/biznes/3304-ilina-e-n-turoperejting-organizaciya-deyatelnosti.html> (дата обращения 22.02.2020).
4. Популярные видеохостинги: топ-10 // Санкт-Петербургская школа телевидения. [Электронный ресурс] URL <http://videoforme.ru/wiki/reklama-ipr-info/obzor-populjarnyh-videohostingov> (дата обращения 22.02.2020).
5. Соколова Н. Социальные сети в России: Цифры и тренды, осень 2018. [Электронный ресурс] URL <https://br-analytics.ru/blog/socseti-v-rossii-osen-2018/> (дата обращения 22.02.2020).

*Дустярова С.Н.
преподаватель кафедры «Национальная идея и основы
духовности»
Каршинский государственный университет*

ПОНЯТИЕ “ДУХОВНОСТЬ” В СЛОВАРЯХ И В СОВРЕМЕННОЙ НАУЧНОЙ ЛИТЕРАТУРЕ

Аннотация: После становления Узбекистана независимой страной, «духовность» стали анализировать и изучать как научное понятие. С 1997 года во всех вузах нашей страны стали преподавать предмет «Основы духовности». Специалисты, подготовленные в этой области в высших учебных заведениях, особенно магистры, должны в достаточной мере знать существующие взгляды, их различия и сходства. Тогда у них будет более полное и глубокое понимание сути духовности. Важно, чтобы этот факт не остался незамеченным в будущих программах и учебниках вузов.

Ключевые слова: духовность, интеллект, развивающееся явление духовности, наука, общество, философское, правовое, научное, художественное, религиозное, моральное.

*Dustyarova S.N.
lecturer of the Department "National idea and the basics
spirituality"
Karshi state University*

THE CONCEPT OF "SPIRITUALITY" IN DICTIONARIES AND IN MODERN SCIENTIFIC LITERATURE

Annotation: After Uzbekistan became an independent country, "spirituality" began to be analyzed and studied as a scientific concept. Since 1997, all universities in our country have begun to teach the subject "Fundamentals of Spirituality." Then they will have a fuller and deeper understanding of the essence of spirituality. It is important that this fact does not go unnoticed in future programs and textbooks of universities.

Keywords: spirituality, intellect, the evolving phenomenon of spirituality, science, society, philosophical, legal, scientific, artistic, religious, moral.

Надо отметить, что в изданном в советские времена «Словаре философии» этому понятию не было и места. Несмотря на то, что сфера применения понятий «духовность» и лежащий в ее основе «духовный», резко расширяется, их лексическое и терминологическое содержание становится настолько богатым, что это позволяет изучать «духовность» как

отдельное научное понятие, его связь с культурой, сознанием, мышлением, мировоззрением, психикой, художественными, политическими, нравственными ценностями и т. д.к. он требует определения своего места в системе понятий, анализа их взаимодействия с ними”⁸¹ .

В словаре "Фарханги забони таджики", изданном в 1969 году, «духовность» интерпретируется как мысль и душа, то есть внутренний духовный и мыслительный мир человека, и в качестве примера приводятся отрывки из

«Ахлоки Насири»(Мораль Насири):

“Ma’naviyati inson mabdai surati vujudi na’viyati o’st”⁸². (Содержание: духовный человек -это обновление содержания его жизни (рост образа жизни). Первое содержание прилагательного “духовный” в словаре относится к смыслу, второе содержание дается как альтернатива человеческой мысли и духа, то есть внутреннего духовного мира и материальности.) В “Толковом словаре узбекского языка”, изданном в 1981 году, нет термина “духовность”. Но в его основе лежат слова «Маъни», «Маъно», а также прилагательные «ma’naviy, ma’nan», то есть «духовный».

Первое значение слова "духовный" выражалось как относящееся к внутренней и духовной жизни человека, а второе содержание-как нравственный (духовный образ человека). В словаре слово "Маъни" дается в двух значениях: первое значение слова - это «маъно», то есть «значение» слова (например: «Gapda ham bir ma’ni bo’lishi kerak» , то есть «в предложении также должно быть значение», - сказала Гульшан (Абдулла Кадыри из «Скорпион из Михраба» (*ниша во внутренней стене мечети, указывающая направление к Мекке*)). Второе значение выражалось как разум, сознание. Например, (falonchi juda bama’ni inson, то есть некий очень бессмысленный(неразумный) человек). Понятие «значение»(маъно) -это выраженное словом понятие или действие, предложение, письмо, произведение и т.д. интерпретируется на основе значения (правильное значение слова, переносное значение слова)⁸³. В “толковом словаре узбекского языка”, изданный в годы независимости, “духовность” был включен как термин и прокомментирован следующим образом: «Духовность»– (араб. - нравственное состояние, все нравственные вещи, свойства) философский, правовой, научный, художественный, религиозный, нравственный и т.п. комплекс представлений и понятий человечества. Хотя слова “маъни” (разум) и “маъно” (значение) в словаре даны отдельно, по содержанию разницы практически нет. Содержание первого слова «значение» (Значение слова). Сторона содержания слова, понятие выраженное словом. Второе значение «содержание» (Рустам

⁸¹ Эркакев А. «Маънавият ва тараққийт» Ташкент, “Маънавият”, 2009. 7-стр.

⁸² Фарханги забони тожики. 1-том, Москва. 1969. 665-б.

⁸³ Толковый словарь узбекского языка . Москва, 1981. 1-том, 454-455 стр.

образумел, читая книги он стал понимать содержание каждого предложения).

Третье значение «разум». (Человек без разума. - У вас есть разум, безразумные). М.Кориев, «Лунные ночи»); Четвертое содержание-это причина, сущность чего либо то; выражается для обозначения сущности⁸⁴. В словаре «*Фарханги забони тожики*» значение слова «маъни»(разум) дано в «маъно» (значение) и можно увидеть в пяти значениях:

1. «мазмунни калом»- значение слова;
2. Идея, мнение;
3. Сущность, содержание (философское понятие);
4. В сознании- душа, психическое состояние человека\$
5. Причина;

Четвертое значение слова, то есть содержание, выражающее внутренний духовный мир человека, не встречается в других словарях⁸⁵. «Независимость» в толковом научно-публицистическом словаре дано описание «духовность» (от арабского «духовность» содержание значения)- совокупность философских, правовых, научных, художественных, нравственных, религиозных представлений и понятий людей. Духовность близка понятиям идеологии, мышления, и они дополняют друг друга⁸⁶. Описание хоть и краткое по объему, но достаточно обширное по содержанию.

Духовность-это не только все представления и понятия людей, но и понятия, нормы, социальные цели, идеалы всего общества и нации. В «Кратком толковом словаре философии» мы встречаем именно это описание данное выше.⁸⁷

В «Национальной энциклопедии Узбекистана» дается более широкое описание «духовности»; «духовность» – понятие, представляющее духовный и ментальный мир человека. Оно включает в себя философское, правовое, научное, художественное, нравственное, религиозное воображение людей. В основе термина «духовность» лежит слово "смысл". Как известно, существует внешний и внутренний мир человека.

Его внешний мир включает в себя его рост, внешний вид, одежду и поведение и т. д. входит. А внутренний мир включает в себя его цель жизни, мысли, желания, чувства...” . Во внешний мир входит цель жизни, мышление, мечты и желания, а также чувства...”⁸⁸.

⁸⁴Толковый словарь узбекского языка. Tashkent, 2006. 2-том, 565-566-стр.

⁸⁵«Фарханги забони тожики». 1-том, Москва, 1969. 665-стр.

⁸⁶«Мустакиллик» толковый научно-публицистический словарь. Ташкент: «Шарк» главная редакция издательско-полиграфического концерна, 1998. 114-стр.

⁸⁷Национальная энциклопедия Узбекистана. 5-том, Т.: государственное научное издательство. 2003. 540-стр.

⁸⁸Ўзбекистон миллий энциклопедияси. 5-сон, Т.: “Ўзбекистон миллий энциклопедияси” Давлат илмий нашриёти, 2003. 540-бет.

В толковом словаре «Духовность: Основные понятия» понятию «духовность» дается следующее описание: «духовность» (араб. Значение, комплекс значений)-социальное явление, всегда идущее бок о бок с материальной жизнью, являющееся неотъемлемой частью жизни человека, народа и общества⁸⁹.

За прошедший период, помимо словарей, в результате исследований ученых, а также специалистов социально-гуманитарной сферы, было издано множество книг, монографий, брошюр и статей, посвященных духовности. Каждый из них подходит к освещению понятия и сущности духовности исходя из своего научного потенциала, мировоззрения и сферы деятельности и проведения исследований.

В первую очередь, сам глава государства тех времён осветил суть духовности. Учитывая значение духовности в развитии независимого Узбекистана и в воспитании гармонично развитого поколения, Ислам Каримов в своих многочисленных работах и лекциях размышляет о духовности. Ислам Каримов в своём произведении «Высокая духовность – непобедимая сила» рассматривал духовность как внутреннюю силу: «Духовность – это внутренний мир человека, непреодолимая сила, которая побуждает человека к духовному очищению, к духовному росту, делает его волевым, целеустремленным, пробуждает его совесть, является критерием всех его взглядов».⁹⁰ Мнения Ислама Каримова о духовности, ее роли в развитии общества и национальном возрождении, об особенностях и формах проявления духовности, ее содержании и сущности с первых лет независимости были поддержаны научной общественностью и интеллигенцией. Большое количество исследований, научно-популярных и публицистических работ появилось в контексте содержания духовности как понятия, ее социальных функций и значения в развитии общества. Однако история происхождения и формирования понятия «духовность» еще полностью не изучена. В научных трактатах и статьях, учебных пособиях и учебниках, написанных различными авторами, направленных на изучение, анализ вопроса духовности, освещение ее места в жизни человека и общества, а также связей с другими сферами, прослеживаются некоторые запутанные, не совпадающие между собой точки зрения. Подходы разных исследователей порой сводятся к тому, что одно отрицает другое, а наличие взаимоисключающих мнений приводит к возникновению путаницы в преподавании.

А.Эркаев выдвигает гипотезу о том, что понятие «духовность», по своему происхождению, имеет два далеких начала. Согласно его первому предположению, это понятие произошло от арабского «Маъни». Первые исламские богословы и философы – мутазилиты-Восил ибн АТО и Амр ибн

⁸⁹ Толковый словарь «Духовность: Основные понятия» Т.: издательско-полиграфический творческий дом имени Г.Гуляма, 2009. 333-стр.

⁹⁰ И.А.Каримов «Юксак маънавият- энгилмас куч». Т.: издательство «Маънавият», 2008. 19-стр.

Убайд основали науку («илм Ат-тафсир») толкования Корана и назвали науку о сущности «Маъни». Учение о сущности вещей и явлений, процессов, природы, общества и Бога они назвали «Маъна», тем самым положив начало понятию духовности в ее основе – «Маъна» как термину⁹¹.

Вторая гипотеза: ни духовность, ни ее корень «Маъна» не были свободны от влияния одного из основных понятий древнеиндийской философии-понятия «Маънас». «Маънас» на санскрите означает пространство разума. Он считался местом расположения разума, этикета, эмоций, чувств, ощущений и воли т. д. в человеческом теле⁹². Продолжая идею, А. Эркаев подчеркивает: между Ближним Востоком, Ираном, Центральной Азией и Индией всегда были хорошо налажены экономические, политические и культурные связи. Наши предки также опирались на индийскую философию при создании исламского религиозно-философского учения. Как мы уже упоминали выше, маънас использовался в суфийском учении в Центральной Азии и Иране в той же форме, что и индусы.

В словаре «Фарханги забони таджики» «маънас» интерпретируется как «махалли унсу улфат» – место друзей и товарищей, и в качестве примера приводится следующий байт Руми:

«Касрхо худ мар – шохонро маънасаст,
Мурдаро хону макон гоъре баст аст».

Содержание: если для королей замки-это место друзей, то для мертвых-это царская могила .

Здесь "маънас" - место, где живет Бог. Употребляется в значении души, выражающей присутствие Бога в душе каждого человека. Под значением король имеется в виду совершенные люди, живущие по пути истины и правды. Под мертвыми подразумеваются люди, ставшие жертвой собственной жадности, без всякого стимула, безразличные, равнодушные, чьи души сравниваются с могилой. В этом байте и замок, и могила являются значением души⁹³. Кстати, А. Эркаев в своей книге «Духовность – знак нации» рассказывает, что «маънас» на санскрите означает разум⁹⁴. Но в словаре «Фарханги забони таджики» "маънас" дается как арабское слово. В других словарях, в частности в вышедшем на русском языке словаре «Философский энциклопедический словарь», отмечается, что "маънас" принадлежит к санскриту⁹⁵.

Таким образом, по нашему мнению, хотя термин «маънас» происходит из санскрита, можно прийти к выводу, что он широко распространен во всем мусульманском мире через арабский язык. Возможно, «маънас» напрямую перешел на персидский язык с санскрита.

⁹¹Эркаев А. «Маънавият – миллат нишони». Т.: Издательство «Маънавият», 1999. 12-стр.

⁹²Эркаев А. Тот же ресурс, 13-стр.

⁹³Эркаев А. «Маънавият – миллат нишони». Т.: «Маънавият» нашриёти, 1999.16-17 стр.

⁹⁴Эркаев А. Ўша манбаа, 16 стр.

⁹⁵Философский энциклопедический словарь. М.: 1983, 337-стр.

Потому что, помимо того, что Иран граничит с Индией, персидский язык и санскрит, языки принадлежащие к одной семье. Следует также отметить, что ранние исламские верующие также изучали индийские религиозно – философские взгляды, и, возможно, таким образом, термин ”маънас”, вошел в арабский язык и был присвоен.

Профессор М. Имамназаров исследует духовность как божественное явление: «духовность-это божественный свет в душе человека. Свет высшей истины, по этой причине наши предки называли человеческую душу «Сокровище века истины». А тайна истины -это такой волшебный талисман, что у него просто не хватит сил, чтобы всего его решить»⁹⁶. По этому мнению можно прийти к выводу, что духовность-это качество, данное человеку Аллахом. Не смотря на то, что взгляды автора становятся некоторой причиной критики, он в своей другой книге – в учебном пособии «Основы нашей национальной духовности», интерпретируя на научном языке свое образное описание, вносит некоторую ясность к этому вопросу: «Духовность – гармония с истинным существованием души человека»⁹⁷. Автор подчеркивает, что описание, которое он дал изначально, является суфийским, символическим описанием и истолкует, что духовность дана человеческому разуму Аллахом, – его сущность снова связывает с религиозностью⁹⁸. Однако нельзя сказать, что данное рассуждение полностью раскрывает сущность понятия «духовность». Причина в том, что религия не является основой духовности, но является её важной составной частью. Это научное понятие нельзя осветить с помощью религиозно-мистических взглядов. Наука опирается только на конкретные факты и логические рассуждения. Тогда он приобретает объективность и правдивость. Духовность- это развивающееся самостоятельное социальное явление. Здесь мы хотели бы отметить, что это учебное пособие (Основы нашей национальной духовности. 2006 г.) М. Имамназарова предназначен для использования в качестве учебника для студентов бакалавриата высших учебных заведений социально-гуманитарного направления. В учебнике содержание тем должны освещены с помощью точных и понятных научных терминов и выражений. В учебнике автор описывает и рассуждает о «духовности» религиозным, художественным и образным смыслом. К. Куронбаев и В. Кучкаров говорят о том, что духовность человека формируется и развивается с момента его осознания себя как личности и до конца жизни, и что возможности и потребности человека в этом отношении безграничны⁹⁹. Авторы указывают, что духовность-это развивающееся явление. Но они недостаточно раскрывают структуру, форму, содержание

⁹⁶Имамназаров М. «Миллий маънавиятимизнинг такомил босқичлари». Тошкент, 1996. 6 стр.

⁹⁷Имамназаров М. Миллий маънавиятимиз асослари. Ўқув кўлланма. Т.: Ўзбекистон файласуфлари миллий жамияти нашриёти, 2006. 33-стр.

⁹⁸Имамназаров М. Миллий маънавиятимиз асослари. Ўқув кўлланма. Т.: Ўзбекистон файласуфлари миллий жамияти нашриёти, 2006. 30-31-стр.

⁹⁹ Куронбоев К., Кучкаров В. “Миллий ғоя ва маънавий хаёт” Т.: “Ma’naviyat” nashriyoti, 2014. 8-стр.

духовности. Кроме этого, в описании духовность присуща только человеку и перестает принадлежать обществу и его структурам и уровням. В отличие от них М. Хамдамова рассматривает духовность как «понятие, воплощающее внутренний мир, духовные переживания, умственные способности, с восприятием общества, нации или отдельного человека». Она даёт описание, что «Духовность имеет широкий смысл и включает в себя такие понятия, как просвещение и культура»¹⁰⁰. В данном описании вопрос о признании духовности не только присущей человеку, но и принадлежащей обществу и нации более подробно освещен, чем данным описанием выше. Но описание осталось односторонним. Во-первых, в описании Хамдамовой духовность ограничивается только внутренним миром. Духовность человека проявляется не только в его внутренних переживаниях, мыслях, желаниях, но и в его поведении, творчестве и в отношении с людьми. Во-вторых, способность-это возможность, одаренная природой, а не духовность. Потому что среди способных, образованных людей встречаются и эгоистичные, корыстные, взяточные, жадные люди, и наоборот, среди людей со средними способностями не так уж и мало добрых, доброжелательных, добрых, веселых, щедрых, то есть людей с высокой духовностью. А.Эркаев рассматривает духовность как социальное явление и дает ей более широкое описание: «Духовность присуща только человеку. Но это не божественное или сверхъестественное природное явление, а социальное явление, связанное с деятельностью человека. В природе нет духовности, человек своей духовностью отличается от животного, а общество-от природы»¹⁰¹. Автор подчеркивает, что духовность-это сущность человека как социо-культурного существа, называя ее целостным комплексом многих оригинальных человеческих качеств, таких как доброта, справедливость, чистота, совесть, непорочность, патриотизм, любовь к красоте, удовольствие, ненависть ко злу, воля, материнство и тому подобное.¹⁰² Сагдулла Отамуратов и Сарвар Отамуратов провели научный анализ описаний о духовности нескольких исследователей: «В прессе и в научной литературе, по нашему мнению в описаниях, данные понятию духовности, остаётся не раскрытой одна лишь важная грань. В частности, духовность-это совокупность духовного и ментального мира человека... Если считать, что понятие, которое воплощает внутренний мир, душевные переживания, умственные способности и восприятие общества, нации или отдельного человека (А. Ибрагимов, Х. Султанов, Н. Джураев), признак рода человека, неотъемлемая составная часть его деятельности, продукт его сознания и интеллекта (А. Жалолов), сущность человека как социо-культурное

¹⁰⁰ М.Хамдамова «Основы духовности.» Т.: Изд. «Наука и технология», 2008. 99-стр.

¹⁰¹ А.Эркаев. «Маънавият – миллат нишони.» Т.: Издательство «Маънавият», 1999. 23-стр.

¹⁰² А.Эркаев Маънавият – миллат нишони. Т.: Издательство «Маънавият», 1999. 23-стр.

существо (А. Эркаев), то “продуктом” деятельности или его “воплощением” остается само понятие”¹⁰³.

Сагдулла Отамуратов и Сарвар Отамуратов также высказали свое отношение к понятию “духовность”: “Духовность-это не только внутренняя психика человека, данное ему “благословение” или существующие позитивные показатели, но вместе с тем и процессы его последовательного развития и существование процессов использования в развитии человека, нации и общества. Он не только развивает человека, нацию и общество, но и развивается сам”¹⁰⁴. В этом описании понятие “духовность” раскрывается ещё шире. Конечно, в приведенных выше описаниях те или иные стороны духовности нашли свое выражение. Исследователи подошли к этому понятию с их исследовательской точки зрения. А совершенное описание формируется в результате обобщения и научного обоснования различных точек зрения. Вот поэтому очень важно их научно проанализировать и выражать в обсуждениях. Поскольку проблема духовности гораздо более сложна и многогранна, данные ей описания также разнообразны. Ислам Каримов пишет о духовности, воплощая все ее стороны, следующее: “Понятие “духовность” в полной мере воплощает в себе идейные, идеологические, культурные, религиозные и нравственные взгляды встречающиеся в жизни общества. Поэтому, размышляя на эту тему, все эти данные взгляды можно обобщить и через понятие “духовность ” выразить в широком смысле”¹⁰⁵.

По этой причине А. Эркаев исходя из различных аспектов духовности, дает несколько описаний и, в заключении стараясь их обобщить, отмечает следующее: “Духовность – это общественное сознание возвышенное до степени религии и традиций, стойкие страсти, понятия, нормы, социальные цели, идеалы, отражённые в культурном наследии и обычаях , национальная воля, помогающая нации достигать определенных целей, а также установленная в обществе умственная и эмоциональная, духовная и идеологическая среда,”¹⁰⁶.

Из вышесказанного становится ясно, что “духовность” - достаточно сложное и противоречивое понятие. В высших учебных заведениях, специалисты, которые обучаются по этой области, особенно магистры, должны на достаточном уровне знать существующие взгляды, их различия и сходства. Только тогда они всесторонне и глубже постигнут всё содержание и смысл духовности. Желательно, чтобы это ситуация не осталась незамеченным в будущих программах и учебниках высших учебных заведений.

¹⁰³ Отамуратов Сагдулла, Отамуратов Сарвар «Духовное возрождение в Узбекистане». Т.:Издательство «Янги аср авлоди», 2003. 177-стр.

¹⁰⁴Отамуратов Сагдулла, Отамуратов Сарвар «Духовное возрождение в Узбекистане». Т.:Издательство «Янги аср авлоди», 2003. 178-стр.

¹⁰⁵И.А. Каримов “Юксак маънавият –енгилмас куч” Т.: Издательство “Маънавият”, 2008. 20-стр.

¹⁰⁶А.Эркаев “Маънавият ва тараққиёт.” Т.: Издательство “Маънавият”, 2009. 50-51-стр.

Использованные источники:

- 1.Эркаев А. Маънавият ва тараққиёт. Т.: “Маънавият” нашриёти, 2009.
- 2.Фарҳанги забони тожики. 1-жилд, Москва. 1969.
- 3.Мустақиллик изохли илмий-оммабоп луғат. Т.: ”Шарқ” нашриёт-матбаа концерни бош таҳририяти, 1998.
- 5.Falsafa qisqacha izohli lug’at. Т.:”Sharq” nashriyot-matbaa konserni bosh tahririyati, 2004.
- 6.Ўзбекистон миллий энциклопедияси. 5-сон, Т.: “Ўзбекистон миллий энциклопедияси” Давлат илмий нашриёти, 2003.
- 7.Ма’naviyat asosiy tushunchalar izohli lug’ati. Т.: G’afur G’ulom nomidagi nashriyot-matbaa ijodiy uyi, 2009.
8. Karimov I.A. Yuksak ma’naviyat – yengilmas kuch. Т.: “Ма’naviyat” nashriyoti, 2008.
- 9.Эркаев А. Маънавият – миллат нишони. Т.: “Маънавият” нашриёти, 1999.
- 10.Эркаев А. Маънавият – миллат нишони. Т.: “Маънавият” нашриёти, 1999.
11. Философский энциклопедический словарь. М.: 1983-yil
- 12.Имомназаров М. Миллий маънавият имизнинг такомил босқичлари. Тошкент
- 15.Имомназаров М. Миллий маънавий таълим асослари. Ўқув қўлланма. Т.: Ўзбекистон файласуфлари миллий жамияти нашриёти, 2006.
- 16.Quronboev Q, Qo’chqorov V. Milliy g’oya va ma’naviy hayot. Т.: “Ма’naviyat” nashriyoti, 2014..
- 17.Hamdanova M. Ma’naviyat asoslari. Т.: “Fan va texnologiya” nashriyoti, 2008.
- 18.Эркаев А. Маънавият – миллат нишони. Т.: “Маънавият” нашриёти, 1999.
- 19.Otamuratov Sadulla, Otamuratov Sarvar. O’zbekistonda ma’naviy-ruhiy tiklanish. Т.:“Yangi asr avlodi”nashriyoti, “O’AJBNT” Markazi, 2003. 177-b.
- 20.Otamuratov Sadulla, Otamuratov Sarvar. O’sha manba, 178-b.
- 21.Karimov I.A. Yuksak ma’naviyat – yengilmas kuch. Т.: “Ма’naviyat” nashriyoti, 2008. 20-b.

Дышекова В.Ф.
студент аспирантуры 1 курса
по направлению подготовки
36.06.01 – Ветеринария и зоотехния
ФГБОУ ВО Кабардино - Балкарский ГАУ
Россия, г. Нальчик
Дадашев А.А., доктор философских наук
профессор
ФГБОУ ВО Кабардино-Балкарский ГАУ

БИОЛОГИЯ В КОНТЕКСТЕ ФИЛОСОФИИ И МЕТОДОЛОГИИ НАУКИ XX ВЕКА

Аннотация: Работа посвящена осмыслению трансформаций предмета и метода биологических наук в контексте философии и методологии XX века. Прослеживая тенденции меж- и трансдисциплинарного тренда в современной науке в целом, особое внимание на гуманитаризацию биологических наук. Изменение традиционной манеры философского анализа становится неизбежным при рассмотрении таких острых проблем, как развитие и возможности генной инженерии, инженерии биогеоценозов, взаимодействия биосферы и человека. Необходимость решения этих задач привела к становлению нового кластера наук: экоэтика, биоэтика, социобиология, биосемиотика.

Ключевые слова: аксиология, праксиология, биологический объект, номотехника, естественный отбор.

Dyshekova V.F.
1st year postgraduate student
in the field of training
36.06.01 – veterinary and animal science
Of the Kabardino - Balkar state agricultural university
Russia, Nalchik
Dadashev A.A., Ph. D.
professor
of the Kabardino-Balkar state university

BIOLOGY IN THE CONTEXT OF TWENTIETH-CENTURY PHILOSOPHY AND METHODOLOGY OF SCIENCE

Annotation: The work is devoted to understanding the transformations of the subject and method of biological Sciences in the context of philosophy and methodology of the XX century. Tracing the trends of inter-and transdisciplinary trends in modern science in General, special attention is paid to the humanitarization of biological Sciences. A change in the traditional manner of philosophical analysis becomes inevitable when considering such acute problems as the development and possibilities of genetic engineering, biogeocenosis engineering, and the interaction of the biosphere and humans. The need to solve these problems led to the formation of a new cluster of Sciences: ecoethics, bioethics, sociobiology, and biosemiotics.

Keywords: axiology, praxiology, biological object, home engineering, natural selection.

В сегодняшней границе своего развития биология требует философского переосмысления классических конфигураций организации познания, создания новейшего вида развития общепризнанных мерок, эталонов также баз академического изучения, новейшего манеры мышления. Формирование биологии в наши время приступает давать все без исключения наиболее конструктивных идей с целью областей равно как био познания, таким образом, обладающих обширные выходы за границы биологии — в науку и цивилизацию в мире. Естествоведение XX в., обладает большим количеством независимых, также в то же время духовно взаимозависимых направленностях: онтологическом, методологическом, аксиологическом и праксиологическом.

Базой нынешнего осмысления общества, считается правило формирования. В нынешней биологии четко обнаруживаются 3 вида законов: первое - эволюционно-генетические, второе - причинные и системно-структурные.

В биологии XIX века и первых десятков лет XX столетия основным был вторичное правило. В минувшие десятилетия XX столетия характеризуются базовым смыслом скелетных концепций. С целью биологии и медицины XIX столетия свойственны разрозненность скелетного также вторичного расклада. Представление их целостности формируется со временем, включая с окончания XIX столетия. Формирование конкретных целых закономерностей значительную значимость сразилась организмическая теория Л. Бергаланфи. Устремляясь, осознать многозначительные возможности формирования биологии Л. Бергаланфи пришел к выводу, то что «организмическое представление считается посылом с целью перехода биологии с природной ситуацией, полиадельфит. Трансформация к целым концепциям в биологии формировался одновременно с подобным в раскладе физике. Совместно с квантами подошли новейшие убеждения в вопрос антагонистичности субъекта также предмета. Они никак не считаются индивидуальными, равно

как древнейшие также рыцарские теории, целиком беспристрастными, равно как после ньютоновской философии» [6,8]. Из биологических вопросов происходили сравнительно нашего осмысления природы людского постижения, представление действительности, что регулярно меняется и формируется. Индивидуальность постижения заключается в этом, то что, отображая действительность, наше изучение высказывает целенаправленность также динамичность субъекта, активного создания, также вследствие того оно неминуемо урезано. Такого Рода аспект предполагает собою в философии познания логичного эмпиризма. Закономерное наблюдение абсолютизирует экспериментальное изучение, что наступает с чувствами. Условная устойчивость данных конфигураций познания обуславливают в беспристрастной истинности чувств, восприятий и взглядов. То, что относится абстрактного познания, в таком случае оно в мощь его огромной удаленности с действительности рассматривается равно как меньше подлинное либо в том числе и трактуется только равно как концепция внешних теоретических построений с целью полнее упорядочивания исключительно вероятной действительности, эмоционального навыка.

Сущность био познания предполагает собою всю концепцию уроков, о закономерностях ее жизни и формирования. Необходимо четко подразумевать, то что более авторитетным методологическим механизмом прояснения природы био в истоке XX в. существовали средние учебные заведения неокантианства, предусматривавший конкретное, высококачественное разделение уроков номотетических и идеографических, основной мишенью таковых считалось определение единых законов и возведения настоящих академических концепций (эталонном такого рода урока создалась агрофизика) [3,5,8]. Они измерили, в том числе и в собственных более единых построениях, традиционная биология остается в степени исключительно схематичной, идеографической знания. Формирование биологии равно как урок номотетической мыслилось непосредственно как цель последующего шага в ее многозначительном и логичном формировании. Обнаружилось, что физикализм и системность (дисциплинированность) – никак не неповторимые варианты. Концепция историзма уже давно знаменитый признак активный природы. В 1-ое десятков обсуждения трудности линий возведения абстрактной биологии, отталкивающегося с мысли схематичной природы традиционной биологии, существовали 3 способы: 1) физикализм, 2) системность и 3) принцип. Правило дополнительности интерпретации взаимоотношений, пребывают к товарищу физикалистское, целое и многозначительное тенденции теоретизации в биологии. Присутствие в первоначальные 2-3 десятилетия XX в. начали этапом серьезнейших тестирований с целью концепции природного отбора. Главным преткновением существовала все без исключения эта ведь основной вопрос целой философии биологии – вопрос

базисной необходимости, в особенности проблема о происхождении трудных организмов также их координированных концепций в рамках активного организма равно как общего целого[1, 2].

С 1940-х гг., совершается активное накапливание данных об биохимических почвах существования, действия, проходили в организме в молекулярной степени. Многочисленные арифметики, физики также химики обращаются к главным био вопросам. Огромный интерес спровоцировало возникновение книжки 1-го с разработчиков фотонной механики Э. Шредингера «Что подобное жизнедеятельность с места зрения физики?» (1943 г.)

В стыке биологии, физики также химии появляются новейшие сферы урока – биохимия, биофизика, биология. Перемещения субстанции выступает общей, никак не точечной, однако мировой, в каком месте единичные большие отделения (общество бактерий также микробов, растений и животных) – компоненты общего единого (биосферы). Подобным компонентом биосферы считается, общество с абсолютно всеми достижениями нынешней культуры. Общество во XX столетии обернулось в условие переустройства и формирования не только лишь биосферы, но и безжизненной природы.

Особенная роль в концепции академического постижения биологии не попросту «естественная наука», но напрямую спланируется с «науками о человеке» (врачебная феногенетика, палеоантропология, нейрофизиология также др.). В соответствии с аспектам, любая академическая сфера познания, рассчитывающая в «зрелость» также умозрительность, обязана исполнять равно как минимум последующим условиям: 1) демонстрировать собою гипотетико - дедуктивное создание, 2) являться верифицируемой также включать во для себя вероятность формулирования обстоятельств собственной своей (возможной) фальсификации также 3) включать в собственном составе согласно последней грани один установление, аргументированно притязующее в значимость многоцелевого закона природы. С данных позиций окончания 1960-х гг. возникла деятельность согласно напряженному глубокому рассмотрению истинной природы сформировавшегося био познания. В линии трудов существовало наглядно представлено, то, что ранее имеющиеся концепции в биологии, в особенности связанные в общее супертеоретическое создание около наименованием «синтетическая концепция эволюции», целиком удовлетворяют приобретенным в логике также методологии урока аспектам «теоретичности» [4,9]. Установка проблемы об потребности формирования «теоретической биологии» никак не совершенно корректна, так как возлюбленная ранее сформирована также имеется равно как минимум в фигуре законов также основ единой также популяционной генетики также во созданных в их точных модификациях микро - и макроэволюции.

В 1970-1980-е гг., когда на просцениум выдвинулись и быстро завоевали популярность различные постпозитивистские концепции и модели науки (концепция «парадигм» Т. Куна, «исследовательских программ» И. Лакатоса и др.), тема линий и способов возведения абстрактной биологии снова существовала кардинальное переформулированная и переосмысленная в мире новейшего методологического агрегата [5,9].

В 1990-е гг. дали большое количество новейшего в формирование наиболее био урока также методологической идеи в рамках философских знаний. Явление существования, ее сути и возникновения снова демонстрирует особенную важность определения данных, информативного расклада присутствие их интерпретации (толкование био строений, обязует наблюдать, макромолекулы клеточки (ДНК, РНК, белки и др.)), требовала наведения мостов с исключительно гуманитарными областями – языкознание, семиология также экзегетика. Создание эволюционно-генетических модификаций трудного действия в обществе активных организмов (в том числе также лица), вызвала социобиологию, вторичную - психологию, этику и др. Все сплетается и преобразовывается в определенный и сознательно, новейший учено-философско-эпистемологическую совокупность. Соответствующее понимание закономерной природы – проблема предстоящего. Нынешняя идеология анализирует собственный предмет никак не отдельно с определенных конфигураций постижения, однако равно как его итог, результат взаимодействия субъекта также предмета природы. Увеличение объекта био урока проходит также во обратном течении – в глубину организма. Подобным способом, новейшее виденье био действительности повергли к изменению в представлении объекта биологии равно как урока. Данная перемена воплотилось во введении в объект биологии абсолютно всех степеней компании существования. При этом развитие разных дисциплин в любом с данных степеней, отражающее новейшие пределе в представлении объекта биологии, обуславливалось никак не только лишь когнитивными, изнутри академическими условиями формирования био познания, однако также включенностью биологии в целую концепцию функционирования урока изнутри сообщества. Значимым фактором в расширении объекта биологии сделалось заявление био урока к вопросу лица. Увеличивается медико-био нацеленность трудов согласно уяснению глубоких био факторов заболеваний, розыску новейших способов излечения также медикаментов.

Сегодняшний промежуток формирования биологии свойственен нарастанием непосредственных взаимосвязей биологии с опытным путем, если микробиология делается орудием никак не только лишь исследования, однако также воздействия в общество активного. Способы разных течений биоинженерии могут помочь биологу преобразоваться, согласно сущности

процесса, в конструктора новейших организмов либо новейших взаимоотношений среди них. Новейшие сферы био исследований призывают переоценки также переосмысления функционировавших в биологии концепций, формирования новейших, их осознания с методологическими, мировоззренческими и ценностными позиций.

Использованные источники:

1. Бауэр Э. Теоретическая биология. М.; Л., 1935.
2. Беклемишев В.Н. Методология систематики. М., 1994.
3. Берталанфи Л. Общая теория систем: критический обзор // Исследования по общей теории систем. М., 1969. С. 28.
4. Борзенков В.Г. Биофилософия в преодолении раскола культуры // Биология и культура. М., 2004.
5. Борзенков В.Г., Северцов А.С. Теоретическая биология: размышления о предмете. М., 1980.
6. Борн М. Физика в жизни моего поколения. М., 1965. С. 230
7. Голубинцев В.О., Данцев А.А., Любченко В.С. Философия для технических вузов. Ростов на Дону: Изд-во «Феникс», 2012.
8. Кашин В.В. Философия наук о живой природе. Оренбург: ГОУ ОГУ, 2006., 109 с.
9. Рьюз М. Философия биологии. М., 1977.

АНАЛИЗ И ОПТИМИЗАЦИЯ ДЕНЕЖНЫХ ПОТОКОВ ОРГАНИЗАЦИИ

Аннотация: научная статья посвящена исследовательскому анализу характеристики анализа и оптимизации денежных потоков организации. Актуальность исследования обусловлена высокой практической ролью управления денежными потоками при обеспечении финансовой устойчивости предприятия. В заключении работы, автором установлено, что процесс управления денежными потоками организации формируется из первоначального анализа самих денежных потоков, а далее из принятия механизмов, направленных на ее оптимизацию.

Ключевые слова: денежные потоки; денежные средства; анализ денежных потоков; оптимизация денежных потоков; управление денежных потоков.

*Evstifeeva U.S.
student of 3 years of study 23-ME
Nakonechnaya T.V.*

ANALYSIS AND OPTIMIZATION OF CASH FLOWS OF THE ORGANIZATION

Abstract: The scientific article is devoted to the research analysis of the characteristics of the analysis and optimization of the organization's cash flows. The relevance of the study is due to the high practical role of cash flow management in ensuring the financial stability of the enterprise. In the conclusion of the work, the author found that the process of managing the organization's cash flows is formed from the initial analysis of the cash flows themselves, and then from the adoption of mechanisms aimed at its optimization.

Key words: cash flows; cash; cash flow analysis; optimization of cash flows; cash flow management.

Совершенствование механизма управления денежными потоками предприятия является одним из главных факторов повышения экономической эффективности производства на современном этапе развития экономики.

Актуальность научного исследования на тематику «анализ и оптимизация денежных потоков организации» обусловлена высокой

практической ролью управления денежными потоками при обеспечении финансовой устойчивости предприятия.

Денежным потоком выступает совокупность распределенных во времени объемов поступления и выбытия денежных средств в процессе хозяйственной деятельности организации. Поступление/приток денежных средств называется положительным денежным потоком, выбытие/отток денежных средств – отрицательным денежным потоком [2].

Важнейшими процедурами управления денежными потоками в системе финансового менеджмента компании выступает их анализ и оптимизация.

Задачами проведения анализа денежных потоков предприятия являются [1]:

- оценка динамики изменения денежных потоков в общем и от каждого вида деятельности по отдельности;
- оценка состава и структуры формирования денежных потоков;
- определение и расчет степени влияния факторов на формирование денежных потоков;
- определение и оценка резервов возможного повышения положительного притока денежных потоков;
- разработка мероприятий по оптимизации денежных потоков предприятия.

При оптимизации денежных потоков организации, руководству необходимо провести изначально анализ, а также оценку степени влияния внутренних и внешних факторов на финансовую деятельность компании.

На рисунке 1 изображены факторы, которые воздействуют на процесс формирования денежных потоков предприятия.

Внешние факторы	Внутренние факторы
<ul style="list-style-type: none"> • Конъюнктура экономики • Конъюнктура финансовых рынков • Система налогообложения предприятий • Система кредитования • Доступность заемного финансирования 	<ul style="list-style-type: none"> • Жизненный цикл предприятия • Амортизационная политика • Финансовые коэффициенты • Финансовый менталитет владельцев • Продолжительность операционного цикла • Неотложенность инвестиционных программ • Уровень обеспечения собственных средств

Рисунок 1 – Факторы, которые влияют на формирование денежного потока организации [3; 4].

Исходя из классификации данных факторов, руководство предприятия приобретает возможность провести оптимизацию денежных потоков путем воздействия на их влияние.

Среди основных методов оптимизации денежных потоков предприятия можно назвать:

- повышение эффективности управления дебиторской задолженностью и увеличение скорости ее взыскания;
- снижение срока хранения на складах предприятия товарно-материальных ценностей;
- проведение мероприятия по оптимизации расходов производственной и управленческой деятельности;
- оптимизация налогообложения и снижение налоговой нагрузки на бизнес;
- применение механизмов бюджетирования при финансовом управлении.

Таким образом, процесс управления денежными потоками организации формируется из первоначального анализа самих денежных потоков, а далее из принятия механизмов, направленных на ее оптимизацию, что позволяет обеспечивать финансовую устойчивость бизнеса.

Использованные источники:

1. Ильиных А.А. Анализ движения потоков денежных средств организации // Молодой ученый. 2019. № 14 (252). С. 101-103.

2. Рыбалко О.А. Понятие денежных потоков и их роль в системе управления // Экономика, управление, финансы: материалы IV Междунар. науч. конф. (г. Пермь, апрель 2015 г.). – Пермь: Зебра, 2015. – С. 192-194.
3. Коваленко О.Г., Полтева Т.В. Управление денежными потоками предприятия // КНЖ. 2016. №4 (17).
4. Золотарева И.В. Управление денежными потоками строительной компании // Вестник евразийской науки. 2012. №4 (13).

Ермоленко А.Л.
начальник кафедры инструментовки и чтения партитур
Военный университет
Ляшенко В.В.
доцент кафедры инструментовки и чтения партитур
Военный университет

О ПРЕДОРКЕСТРОВОМ ПЕРИОДЕ ОТЕЧЕСТВЕННОЙ ДУХОВОЙ МУЗЫКИ

Аннотация: статья посвящена истории отечественной духовой музыки в период, предшествующий формированию духового оркестра. Авторы приводят свидетельства использования различных типов ансамблей духовых инструментов, дают краткую характеристику музыкальных сочинений этого периода.

Ключевые слова: духовая музыка, ансамбль духовых инструментов, Д. Паизиелло, К. Каноббио, Д. Зорин, В. Пашкевич, Д. Бортнянский.

Ermolenko A.L.
Head of the Department of Instrumentation and Score Reading
Military University
Lyashenko V.V.
Docent of the Department of Instrumentation and Score Reading
Military University

PRE-ORCHESTRA PERIOD OF RUSSIAN BRASS MUSIC

Resume: the article is devoted to the period of Russian brass music in the preceding formation of the brass band. The authors lead to the use of various types of ensembles of wind instruments, give a brief description of the musical compositions of this period.

Keywords: wind music, wind instrument ensemble, Paisiello, Canobbio, Zorin, Pashkevich, Bortnyansky.

Духовой оркестр, как коллектив, обладающий определенными признаками (стабильный состав, большой диапазон, уравновешенность регистров, многообразие тембров, «хоровой» принцип дублирования партий в основной группе и т.п.) [1, 10] сформировался в нашей стране на рубеже XVIII-XIX веков. Созданию духового оркестра предшествовал длительный «предоркестровый» период, связанный с формированием и развитием различных видов ансамблей духовых инструментов.

Первые упоминания об отечественной духовой музыке относятся ко второй половине X века. «Повесть временных лет» описывает осаду Киева печенегами в 968 году, в ходе которой воины воеводы Притича уселись в насады и «вструбиша вельми, и людье во граде кликнуша». Трубный звук в сочетании с воинственными возгласами обратил печенегов в бегство [4, 65].

К XVI веку относится один из первых отзывов иностранцев об использовании ансамбля трубачей в нашей стране – это опубликованный Т. Ливановой фрагмент из записок немецкого дипломата и путешественника Сигизмунда Герберштейна, посещавшего Россию в 1517 и 1526 годах. «У них много трубачей: когда они затрубят по отечественному обычаю все вместе, – пишет он, – тогда услышишь чудные и необыкновенные созвучия» [3, 316].

Сохранилось немало свидетельств бытования различных музыкальных духовых коллективов в XVII веке. Н. Финдейзен приводит любопытный фрагмент о праздновании свадьбы царя Михаила Федоровича, состоявшемся в начале февраля 1626 года: «Второй день свадьбы начался музыкой. Когда царь вышел из сенника в мыльню, начали играть в сурны и трубы и бить по накрам» [5, 310]. Автор «Очерков» предполагает, что под музыку совершались и другие «незамысловатые потехи» при царском дворе, для чего в середине XVII века был установлен значительный по численности штат придворных музыкантов. «На царском дворе, – свидетельствует извлечение из трактата Г. Котошихина «О России», – играют в трубки и в суренки и бьют в литавры... А будет трубников и литаврщиков и суренщиков в царском доме всех человек сто» [2, 19]. Далее там же сообщается, что не только при дворе, но и на свадьбах у бояр «в трубки трубят и бьют в литавры».

В 1672 году состоялось первое представление театра при царском дворе. Наряду с вокальной, в представлении звучала и инструментальная музыка, которая, по предположению Н. Финдейзена, «требовала преимущественно трубных фанфар» [5, 321].

К 90-м годам XVII века относятся первые известия о появлении в России ансамбля гобоев. В приведенном Т. Ливановой отрывке из «Дневника путешествия в Московию» И. Корба сообщается, что «бранденбургский посол привез с собой семь мальчиков музыкантов (их называли гобоистами), которых царь купил у их учителя за 1200 золотых» [3, 328]. Н. Финдейзен в «Очерках» пишет о том, что послу Андрею Измайлову поручается купить в Берлине «робят маленьких с габои... каких он купил наперед тому в Королевцу». Посол поручение выполнил, приобрел в 1702 году за 1400 золотых «из знатных музыкантов шесть человек робят...» [5, 346].

19 февраля 1711 года были утверждены «Штаты кавалерийских и пехотных полков с показанием оных по губерниям», в которых было указано обязательное число военных музыкантов. Устанавливался

следующий состав музыкантов: в 33 кавалерийских полках – 33 иноземных гобоиста (по одному на полк), 330 русских гобоиста, 66 трубачей, 660 барабанщиков; в 42 пехотных полках – 42 иноземных гобоиста, 672 русских барабанщика; в каждом гарнизонном полку – 1 гобоист иностранец, 8 русских гобоистов и 16 барабанщиков.

Вторая половина XVIII века стала временем широкого распространения музыки в самых обширных слоях русского общества. Особенно способствовали этому так называемые помещичьи оркестры, состоявшие, как правило, из крепостных музыкантов. Основным типом подобных коллективов был ансамбль из восьми человек, включавший 2 флейты, 2 кларнета, 2 фагота и 2 валторны. Иногда такой состав исполнителей использовался в двойном замещении, что, очевидно, было связано с исполнением музыки на открытом воздухе. Основу репертуара подобных коллективов составляли переложения фрагментов из популярных произведений оперно-симфонической музыки.

Сохранившийся нотный материал ансамблевого периода отечественной духовой музыки невелик по количеству – это сочинения Д. Паизиелло, К. Каноббио, Д. Зорина, В. Пашкевича и Д. Бортнянского.

Дивертисменты Джованни Паизиелло созданы в 70-е годы XVIII века. Произведения сгруппированы в два сборника. Первый состоит из четырех номеров пасторального характера: Диана, Полдень, Заход солнца, Отход ко сну. Все дивертисменты этого сборника написаны в одной тональности (Es) и предназначены для исполнения септетом духовых инструментов – 2 флейты, 2 кларнета, 2 валторны и фагот. Второй сборник более разнообразен по тональности, характеру пьес и составу ансамбля – количество исполнителей варьируется от трех до семи.

Д. Зорин в опере «Перерождение», созданной в 1777 году, впервые вводит в обиход ансамбль духовых для сопровождения оперных вокальных партий.

Примеры употребления группы духовых инструментов в качестве оркестрового сопровождения в творчестве В. Пашкевича содержат партитуры опер «Февей» (1786) и «Санкт-петербургский гостиный двор» (1792).

В 1786 году для любительского театра при «малом» дворе наследника Павла Петровича и его жены, великой княгини Марии Федоровны, Д. Бортнянским была сочинена опера «Сокол». К одному из сохранившихся экземпляров партитуры присоединены на вкладных листах переложения восьми номеров оперы, предназначенные для исполнения ансамблем духовых инструментов (2 кларнета, 2 валторны, 2 фагота).

Марш К. Каноббио, сочинен в 1790 году для музыкально-драматического представления «Начальное управление Олега». Партитура марша включает четыре трубы (строй «С»), два тромбона, два серпента и треугольник.

Партитуры представляют возможность проанализировать инструментовку, характерные черты трактовки духовых инструментов, проследить истоки возникновения приемов построения вертикали и особенности сочетания тембров.

Таким образом, наиболее употребительными типами духовых исполнительских коллективов предоркестрового периода были: ансамбли трубачей, ансамбли медных духовых и ударных инструментов, ансамбли гобоев и смешанные ансамбли, состоящий из флейт, кларнетов, фаготов и валторн.

Ансамбли духовых инструментов сформировались и развились в армейской среде, а затем получили широкое распространение в бытовой и театральной музыке.

Сохранившиеся нотные образцы произведений для ансамблей духовых инструментов относятся к последней четверти XVIII века и содержат ценный материал для исследователей в области духовой инструментовки.

Использованные источники:

1. Аксенов Е. Оркестр и партитура. Москва: Композитор, 2006. 104 с.
2. Котошихин Г. О России в царствование Михайловича. Санкт-Петербург: СПб. Типография И. Глазунова, 1913. 56 с.
3. Ливанова Т. Очерки и материалы по истории русской музыкальной культуры. Москва: Искусство, 1938. 360 с.
4. Повесть временных лет. Москва: Родная страна, 2016. 544 с.
5. Финдейзен Н. Очерки по истории музыки в России. Т.1. М.-Л.: Музсектор Госиздата 1928. 364 с.

Есинова Э.Б.

студент

научный руководитель: Баирова Н.И., к.э.н.

доцент

ФГБОУ ВО «Калмыцкий государственный университет

им. Б.Б. Городовикова»

г. Элиста

**ГОСУДАРСТВЕННЫЙ КОНТРОЛЬ И НАДЗОР В СИСТЕМЕ
ГОСУДАРСТВЕННОГО УПРАВЛЕНИЯ НА ПРИМЕРЕ
ФЕДЕРАЛЬНОЙ СЛУЖБЫ ПО НАДЗОРУ В СФЕРЕ
ЗДРАВООХРАНЕНИЯ ПО РЕСПУБЛИКЕ КАЛМЫКИЯ**

Аннотация: В статье анализируется деятельность Федеральной службы по надзору в сфере здравоохранения по Республике Калмыкия, осуществляющего контрольно-надзорные функции в сфере здравоохранения. Выявлены проблемы контрольно-надзорной деятельности учреждения и представлены пути их решения.

Ключевые слова: контроль, надзор, Росздравнадзор, проблемы контрольно-надзорной деятельности, пути решения.

Esinova E.B.

student

supervisor: Bairova N.I., Ph. D.

Associate Professor

B. B. Gorodovikov Kalmyk State University

Russia, Elista

**STATE CONTROL AND SUPERVISION IN THE PUBLIC
ADMINISTRATION SYSTEM ON THE EXAMPLE OF THE FEDERAL
SERVICE FOR SUPERVISION OF HEALTHCARE
FOR THE REPUBLIC OF KALMYKIA**

Abstract: the article analyzes the activities of the Federal service for supervision of healthcare in the Republic of Kalmykia, which performs control and Supervisory functions in the field of healthcare. The problems of control and Supervisory activities of the institution are identified and ways to solve them are presented.

Keywords: control, supervision, Roszdravnadzor, problems of control and supervision, solutions.

Федеральная служба по надзору в сфере здравоохранения (Росздравнадзор) образована в соответствии с Указом Президента Российской Федерации от 9 марта 2004 г. № 314 «О системе и структуре федеральных органов исполнительной власти» и является федеральным органом исполнительной власти, осуществляющим функции по контролю и надзору в сфере здравоохранения.

Служба осуществляет свою деятельность непосредственно и через свои территориальные органы во взаимодействии с другими федеральными органами исполнительной власти, органами исполнительной власти субъектов Российской Федерации, органами местного самоуправления, общественными объединениями и иными организациями.

Анализ контрольно–надзорной деятельности Росздравнадзора по Республике Калмыкия показал, что за отчетный период сотрудниками ТО Росздравнадзора по Республике Калмыкия проведены 234 комплексных и тематических проверок по государственному контролю в сфере здравоохранения.



Рисунок 1. Динамика проверок в период с 2017–2019 гг.

За отчетный год проводились все виды государственного контроля в сфере здравоохранения, возложенные на Росздравнадзор по Республике Калмыкия:

- по контролю качества и безопасности медицинской деятельности;
- по федеральному государственному надзору в сфере обращения лекарственных средств;
- государственному контролю за обращением медицинских изделий.

В результате проведенных Росздравнадзором мероприятий за 2019 г. всего было изъято из обращения 738 серий лекарственных средств, качество

которых не отвечает установленным требованиям. Динамика показателей за последние четыре года показывает, что количество изъятых серий лекарственных средств существенно снизилась с 1938 серий в 2016 году до 738 серий в отчетном году.

Показатели несоответствия, выявленные при предварительном контроле для препаратов отечественного и зарубежного производства, практически одинаковы:

1. Лекарственные формы для внутривенного и внутримышечного введения - механические включения, остаточные органические растворители, цветность, стабильность.

2. Твердые нестерильные лекарственные формы — посторонние примеси, количественное определение, растворение, маркировка.

3. Жидкие нестерильные лекарственные формы — описание, количественное определение.

На этапе предварительного контроля готовых лекарственных средств бракуются также фармацевтические субстанции, которые используются в их производстве, в том числе по таким критическим показателям, как: «Подлинность», «Остаточные органические растворители», «Цветность», «Температура плавления», «Удельное вращение», «Прозрачность».

Рассматривая данные выявления фальсифицированных лекарственных препаратов можно сделать вывод о том что за последние три года динамика показателей увеличивается, что говорит о недостаточном контроле за обращением лекарственных средств со стороны Росздравнадзора (рис. 2).



Рисунок 2. Динамика выявления фальсифицированных лекарственных препаратов за период 2013 г. – 2019 г.

В целом рассматривая контрольно–надзорную деятельность Росздравнадзора можно сделать вывод о том, что для достижения наилучших результатов надзорной деятельности, необходимо, чтобы работа

Управления Росздравнадзора по Республике Калмыкия проводилась в тесном взаимодействии с органами исполнительной власти республики и институтами гражданского общества. Это позволит более действенно устранять выявленные нарушения и предупреждать новые.

Что касается анализа нормативных правовых актов, регламентирующих деятельность Росздравнадзора и его должностных лиц, определяющих обязательные требования, выявлено наличие ограничения возможности применения мер административного воздействия на юридических лиц и должностных лиц, допустивших нарушения качества и безопасности медицинской деятельности.

В целях систематизации, сокращения количества и актуализации обязательных требований по контролируемым видам деятельности в сфере здравоохранения Росздравнадзору необходимо:

– пересмотреть и актуализировать (включая отмену неэффективных и избыточных обязательных требований) перечень нормативных правовых актов, устанавливающих обязательные требования, соблюдение которых оценивается при проведении мероприятий по контролю (надзору) юридических лиц и индивидуальных предпринимателей, осуществляющих деятельность в сфере здравоохранения (медицинская деятельность, оборот лекарственных препаратов, оборот медицинских изделий), а также по видам предпринимательской деятельности, осуществляемым в уведомительном порядке, которые поддерживаются в актуальном состоянии;

- рассмотреть предложения об исключении отдельных правовых актов из перечней правовых актов СССР и РСФСР, подлежащих признанию утратившими силу или недействующими на территории Российской Федерации с 01.02.2020;

– применять проверочные листы, содержащие исчерпывающий перечень вопросов по всем видам контроля (надзора), в ходе проведения плановых проверок.

Использованные источники:

1. Сведения о результатах проверок, проведенных Территориальным органом Росздравнадзора по Республике Калмыкия за 2019 год URL\\ <https://08reg.roszdravnadzor.gov.ru/control/results>
2. Информация о результатах государственного контроля (надзора) в сфере обращения лекарственных средств за 9 месяцев 2020 года URL\\ <https://08reg.roszdravnadzor.gov.ru/drugs/qualitycontrol>
3. Официальный сайт Территориального органа Росздравнадзора по Республике Калмыкия <https://08reg.roszdravnadzor.gov.ru/> (дата обращения 12.10.2020)
4. Официальный сайт «Консультант плюс»/ электрон. путеводитель/URL:http://www.consultant.ru/document/cons_doc_LAW_12097_1/ (дата обращения: 12.10.2020)

*Ешимбетов У.
ассистент-преподаватель
кафедры методики преподавания географии
Нукусский государственный институт имени Аженияз
Наурузбаева Г.
старший преподаватель
кафедры экономической и социальной географии
Каракалпакский государственный университет имени Бердаха
Дальжанов К.
ассистент-преподаватель
кафедры экономической и социальной географии
Каракалпакский государственный университет имени Бердаха*

**МЕТОДИЧЕСКИЕ ВОПРОСЫ АНАЛИЗА И ПРОГНОЗИРОВАНИЯ
ИНДУСТРИАЛЬНОГО РАЗВИТИЯ РЕГИОНА С УЧЕТОМ
РАЦИОНАЛЬНОГО ИСПОЛЬЗОВАНИЯ МИНЕРАЛЬНЫХ
РЕСУРСОВ**

Аннотация. В статье рассматриваются методические вопросы анализа и прогнозирования индустриального развития региона с учетом использования минеральных ресурсов. Выявление ресурсного потенциала региона для дальнейшего развития промышленности.

Ключевые слова: минеральные ресурсы, прогнозирование, ресурсный потенциал, комплексное освоение, экологические результаты.

*Eshimbetov U.
Assistant Teacher of the Department of Methods of Teaching
Geography
Nukus state Institute of the names of Ujeneza
Nauruzbayeva G.
Senior lecturer of the Department of Economic and Social Geography
Karakalpak State University named after Berdakh
Dolganov K.
accident-lecturer of the Department of economic and social geography
Karakalpak State University named after Berdakh*

**METHODOLOGICAL ISSUES OF ANALYSIS AND FORECASTING OF
INDUSTRIAL DEVELOPMENT OF THE REGION, TAKING INTO
ACCOUNT THE RATIONAL USE OF MINERAL RESOURCES**

Abstract. The article deals with the methodological issues of analysis and forecasting of the industrial development of the region, taking into account the use of mineral resources. Revealing the resource potential of the region for further industrial development.

Keywords: mineral resources, forecasting, resource potential, comprehensive development, environmental results.

Применение стратегического планирования к индустриальному развитию региона обусловлено усложнением условий производства и добычи исходного сырья, а также эволюцией теоретико-методического инструментария к управлению на территориальном и отраслевом уровне.

Существовавшие методы экономического прогнозирования, долгосрочного и текущего планирования, базирующиеся на разработке экономико-математических моделей, на основе которых пытались установить тенденции развития производства, были эффективны лишь в условиях относительно стабильных производственных стратегических целей, заключавшихся главным образом наращивании производства и насыщении рынка продукцией переработки минерально-сырьевых ресурсов.

В процессе стратегического планирования спроса и производства минерально-сырьевых ресурсов можно условно выделить две основные стадии: разработка стратегии функционирования предприятий промышленности (прогнозирование и долгосрочное планирование) и определение тактики ее реализации (текущее планирование). Следовательно, разработка стратегии представляет собой процесс выявления общих направлений деятельности предприятий по разведке, добыче и переработке минерально-сырьевых ресурсов, причем не абстрактных, а реальных. Таким образом, стратегия выражает собой реакцию предприятия на объективные внешние и внутренние факторы, влияющие на его деятельность.

Предлагается схема стратегического планирования производства минерально-сырьевых ресурсов, включающая в себя ряд последовательных этапов[1].



Схема. 1.3.1. Стратегическое планирование добычи и переработки минерально-сырьевых ресурсов

На первом этапе промышленные предприятия проводят маркетинговые исследования внешней и внутренней среды. В их ходе определяются основные элементы, составляющие процесс добычи и переработки минерально-сырьевых ресурсов, разрабатываются прогнозы перспективного состояния внешней среды, дается оценка текущего положения деятельности [1].

В ходе второго этапа определяются цели и перспективные направления деятельности.

На третьем этапе, используя инструментарий стратегического анализа и сопоставляя цели с результатами исследований факторов внешней и внутренней среды, которые зачастую выступают в качестве ограничивающих факторов достижения желаемых показателей, определяют разрыв между ними. Затем формируются различные альтернативы стратегии[2].

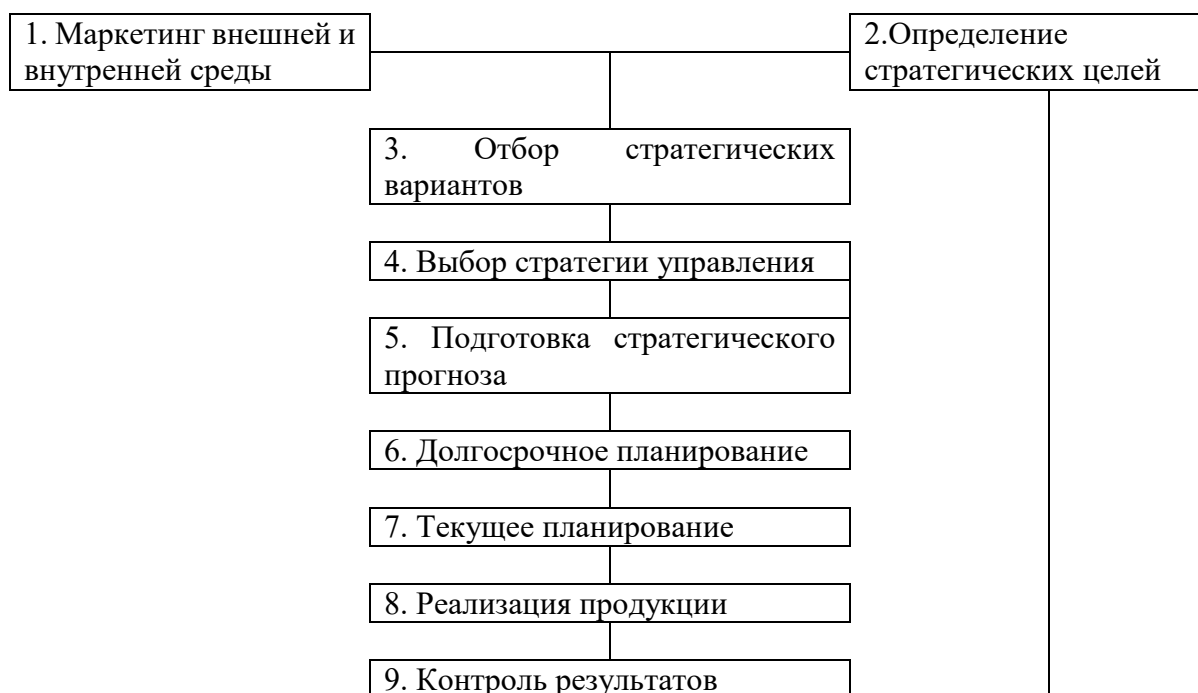
Четвертый этап предусматривает выбор одной из альтернатив и ее проработка на основе методов многокритериальной оценки[1].

На пятом этапе подготавливается окончательный стратегический прогноз деятельности предприятий по добыче и переработке минерально-сырьевых ресурсов [1].

В ходе шестого этапа разрабатываются долгосрочные планы и программы добычи и переработке минерально-сырьевых ресурсов [1].

На седьмом этапе, на основе стратегического прогноза и результатов долгосрочного планирования осуществляется разработка текущих планов.

Восьмой и девятый этапы, не представляют непосредственно стадии стратегического планирования, но они определяют предпосылки, для разработки новых планов исходя из уровня реализации намеченных целей и разницей плановыми показателями, и их фактическим выполнением [1]. Вместе с тем следует отметить, что к числу основных недостатков стратегического планирования спроса на минерально-сырьевые ресурсы следует отнести слабую адаптацию методологии прогнозирования современным реалиям. В первую очередь здесь следует выделить:

- специфику существующей формы товарного обращения и проявления монополизма на товарных рынках;
- отсутствие комплексности, системности и оперативности при разработке стратегических планов;
- слабый учет в прогнозах цикличности и неравномерности динамики добычи и переработки минерально-сырьевых ресурсов;
- ориентация предприятий на неэффективный инструментарий прогнозирования и планирования, зачастую их низкий уровень рыночной ориентации;
- разработка прогнозных показателей на основе недостаточно обоснованных сценариев развития промышленности и ее потребительского сектора;
- отсутствие взаимосвязи прогнозов спроса на минерально-сырьевые ресурсы с перспективными планами социально-экономического развития региона.

Исходя из этого, можно сделать вывод, что возможности совершенствования инструментария стратегического планирования промышленности на основе комплексной переработке минерально-сырьевых ресурсов обуславливаются рядом факторов. Среди них особенно следует выделить сложность оценки и слабая проработка теоретических основ, ориентация главным образом на набор ситуативных целей, а не систему взаимосвязанных, взаимодополняющих целей, значительная степень неопределенности получения результатов при реализации стратегий, высокая трудоемкость и длительность процесса разработки, требующая значительных финансовых расходов и использования высококвалифицированных специалистов и др.

Эффективность стратегического планирования развития промышленных предприятий определяется возможностью учета следующих основных принципов[3]:

- единство и целостность основных принципов и методологии стратегического планирования на различных уровнях управления (предприятие – отрасль – регион – республика);
- разграничение полномочий между органами управления различных уровней и сбалансированность стратегических документов по приоритетам,

целям, задачам, показателям, финансовым и иным потокам, мероприятиям и срокам их реализации;

- преемственность и непрерывность при разработке и реализации региональных планов и программ, с учетом конечных результатов ранее принятых документов стратегического планирования.

Выбор инструментария реализации стратегических целей должен исходить из необходимости достижения заданных ориентиров при минимальных затратах ресурсов, исходя из разработанных и утвержденных документов. При этом все участники процесса несут одинаковую ответственность за своевременность и качество разработки, реализации и корректировки документов, обеспечения результативности и эффективности решения задач, поставленных в стратегии. Следует отметить, что документы стратегического планирования должны быть официально опубликованы и доступны для широкого обсуждения общественности.

При обосновании целей и задач необходимо исходить из реальных возможностей их реализации в намеченные сроки с учетом ресурсных ограничений и возможных рисков. Кроме того, должна быть обеспечена возможность достижения количественных и качественных целевых показателей, критериев и методов их оценки, в увязке с другими стратегическими документами, в том числе региональными и отраслевыми.

Следует выделить важную особенность стратегии догоняющей индустриализации восточноазиатских стран, которая заключалась в поэтапном развитии отраслей промышленности. На первом этапе рост промышленности строится главным образом на формировании трудоемких производств с использованием дешевой рабочей силы (легкая и пищевая промышленность, промышленные стройматериалы). По мере развития промышленности происходит накопление капитала и удорожание рабочей силы, приводящие к трансформации структуры с ориентацией отрасли на материалоемкое и энергоемкое производство с углубленной переработкой минерально-сырьевых ресурсов (металлургию и химию), после чего рост осуществляется за счет таких капиталоемких и наукоемких производств, как машиностроение, электроника и др., ориентированных на экспорт. Такая модель экономического развития, отражающая структурные сдвиги в промышленности, характеризуется как «ступенчатая технологическая индустриализация» [4,9]. Представленный опыт структурной динамики индустриального развития согласуется с этапами становления обрабатывающей промышленности, при помощи базовых отраслей реального сектора экономики: энергетики, химии, промышленных стройматериалов и др.

В рамках структурной перестройки особая роль отводится выявлению ресурсного потенциала региона для дальнейшего развития промышленности. Понятие «ресурсный потенциал» выступает

концептуальным индикатором регионального развития и рассматривается как совокупность природных и экономических ресурсов, расходуемых для достижения конечного результата[5]. Следовательно, данная категория включает в себя как ресурсный компонент, так и в определенной мере результативный компонент, обусловленная эффективностью использования имеющихся ресурсов[6]. Данный подход наиболее обоснован с точки зрения оценки ресурсного потенциала региона, т.к. ресурсная составляющая позволяет определить потенциальные возможности региона, а результативная – его способность и производить конкурентоспособную продукцию.

В процессе исследования было установлено, что имеющиеся недостатки при освоении региональных минерально-сырьевых ресурсов в большей мере обусловлены слабым научно-методическим обоснованием их показателя оценки, достигнутых результатов, адекватно отражающих реально существующие региональные приоритеты экономического развития. Однако, очевиден и высокий уровень адаптации минерально-сырьевого комплекса к реалиям его функционирования, обусловленный в том, что[7,10]:

- минерально-сырьевые ресурсы в большинстве своем являются уникальными, обладающие устойчивым рынком сбыта, вследствие большого набора потребительских свойств;

- освоение минерально-сырьевых ресурсов не требует использования высоких технологий и сложных схем маркетинга;

- по энергоемкости, природоохранным и другим индикаторам они не представляют интереса для экономически развитых государств и в условиях открытой экономики будут высоколиквидными для страны или региона-производителя.

В основе обоснования стратегии развития минерально-сырьевого потенциала следует использовать показатель преимущество позитивных долгосрочных социально-экономических, экологических и инновационно-инвестиционных эффектов над негативными, вследствие роста нагрузки на окружающую среду. Именно поэтому, в качестве индикатора оценки эффективности стратегии комплексного освоения минерально-сырьевого потенциала целесообразно применять критерий максимального интегрированного эффекта, учитывающего как социально-экономические, экологические и другие позитивные долгосрочные результаты, отражающие рост уровня благосостояния населения.

В общем виде положительные эффекты, возникающие при комплексном использовании региональной минерально-сырьевой базы, включают[8]:

- экономические: снижение затрат на транспортировку минерально-сырьевых ресурсов из других регионов; использование инфраструктурного обеспечения; возможности получать дополнительный доход за счет

увеличения регионального и межрегионального спроса на товары из минерально-сырьевых ресурсов; рост природно-ресурсных и других налогов;

– экологические: сокращение ущербов окружающей среде за счет использования вторичных ресурсов, отходов и ресурсов техногенных месторождений; снижение влияния разработки минерально-сырьевых ресурсов на окружающую природную среду вследствие контролируемости экологических процессов;

– социальные: прирост рабочих мест в горной отрасли и смежных перерабатывающих, обслуживающих производствах; инфраструктурных и социальных секторах экономики; удовлетворение разносторонних потребностей населения; сокращение затрат трудоспособного населения на передвижения.

В целом к позитивным результатам, обусловленными комплексным освоением минерально-сырьевого потенциала региона следует отнести:

– сокращение расходов на транспортировку минерального сырья из сопредельных территорий; загрузка инфраструктур; возможность получения дополнительных доходов путем роста спроса на продукцию горнодобывающего производства; повышение ресурсных и экологических налогов;

– снижение негативных воздействий на окружающую среду за счет потребления и утилизации вторичных ресурсов и отходов; сокращения нагрузки на экосистему вследствие экологического контроля за производственными процессами;

– создание дополнительных рабочих мест в горнодобывающей отрасли и смежных перерабатывающих производствах, сокращение транспортных расходов населения и рост его благосостояния.

К негативным результатам следует отнести:

– дополнительные затраты на реконструкцию функционирующих и строительство новых производственных объектов на основе местного минерального сырья;

– рост нагрузки на экосистему, вследствие освоения месторождений полезных ископаемых;

– повышение численности населения.

Методика выявления основных приоритетов и этапов реализации стратегии заключается в следующем:

– систематизируется информационная база, составленная на основе бизнес-плана освоения минерально-сырьевого потенциала региона;

– осуществляется выбор экономических показателей и весомых региональных факторов, не возможных при современном уровне экономических знаний реальной стоимостной оценке. В качестве основной цели региональной политики освоения минерально-сырьевых ресурсов при

этом выступает обеспечение социально-экономических и экологических параметров обеспечения условий жизнедеятельности населения региона;

– классические индикаторы оценки инвестиционных проектов (доходность, рентабельность, сроки окупаемости и наличие собственных прямых и оборотных средств у инициатора проекта) являются достаточными для их оценки, но не обязательными для реализации. При разработке региональной стратегии должен осуществляться выбор проектов развития и бизнес-планов с позиций достижения соответствующих ориентиров, позволит выявить очередность их реализации и сформировать приоритеты вовлечения местного минерального сырья в процесс регионального воспроизводства;

– разрабатывается организационно-регулирующего инструментария, способствующего достижению выбранной стратегии. Так, при реализации высокодоходных с точки зрения коммерческой выгоды проектов целесообразно осуществление мер по максимизации изъятия рентного дохода и перераспределение сверхдоходов для дальнейшего роста производственной деятельности. Вместе с тем, высокие значения оценки социально-экономических и экологических индикаторов проектов, не приносящих коммерческий доход, обуславливает проблему выявления форм и методов инвестирования, государственной поддержки, определения портфеля государственных заказов и дифференцированного ряда льгот для их реализации;

- обоснование минерально-сырьевой стратегии региона на основе включения конкретных проектов в программу деятельности хакимиятов, на территории которых они осуществляются.

К преимуществам данного подхода следует отнести:

- оценка и учет приоритетных направлений социально-экономического развития региона с учетом экологических факторов;
- удобство и простота расчетов показателей;
- учет региональных особенностей и возможностей комплексного освоения и переработки минерально-сырьевых ресурсов.

Использованные источники:

1. Габдулин Т.Г. Стратегическое планирование производства минерально-сырьевых ресурсов. Вестник Челябинского государственного университета, 2002. – С.86-93.
2. Юсупов А.А. Управление конкурентоспособностью предприятия на основе инноваций. Диссертация на соискание ученой степени кандидата экономических наук. Казань. 2000 г.
3. Селиверстов В.Е. Региональное стратегическое планирование: методология, практика, инструменты, институты. Диссертация на соискание ученой степени доктора экономических наук. Новосибирск. 2011 г.

4. Линь Ифу, Цай Фан, Ли Чжоу. Китайское чудо: стратегия развития и экономическая реформа: пер с кит. - М., 2001.
5. Клоцвог Ф.Н. Кушникова И.А. Макроэкономическая оценка ресурсного потенциала российских регионов. Проблемы прогнозирования. 1998. - № 2.
6. Акбердина В.В. Инновационно-технологический потенциал региона: вопросы оценки и динамики. Региональная экономика: теория и практика. 2009. - № 23.
7. Гришин В. И. и др. Методический подход к стратегии развития региональной минерально-сырьевой базы // Вестник РЭА, 2010. - № 2 . – С. 102-109.
8. Буравцов В.В. Экономическое обоснование стратегии эффективного использования минерально-сырьевой базы региона (на примере Тульской области). Автореферат диссертации на соискание ученой степени кандидата экономических наук. М.: 2010 г.
9. Abdunazarov N.M., Choriev A.Q., Embergenov N.J., Oteuliev M.O. Issues of human economic activity and environmental protection. Экономика и социум. №11(78), ноябрь 2020. https://a78cf8ac-3ef5-4670-8fcd-a900ec94fdfb.filesusr.com/ugd/b06fdc_8e57453909bc42f6bc78b57223fc66f2.pdf?index=true
10. Embergenov N.J., Oteuliev M.O., Karimbaev K., Madaminov X.R. The importance of mineral raw material resources in the organization and placement of industrial sectors in the Republic of Karakalpakstan. Экономика и социум. №10 (77), октябрь 2020. –С 59-62

*Жабборова С.Т.
преподаватель кафедры узбекского языка,
педагогике и физической культуры
факультет защиты растений и агрохимии
Андижанский институт сельского хозяйства и агрохимии
Узбекистан, г. Андижан*

ПРОБЛЕМА ПОВЫШЕНИЯ ИНТЕРЕСА СТУДЕНТОВ К РУССКОМУ ЯЗЫКУ В ВУЗЕ

Аннотация: В настоящее время эта проблема актуальна, так как однотипность и шаблонность уроков снижают интерес к обучению, делают учебный процесс скучным и бесперспективным. А уж в высшей школе такое проведение уроков вообще недопустимо. Русский язык является одним из сложных и отнюдь не самых интересных предметов в высшей школе. Поэтому необходимо ещё в высшей школе развить у учащихся интерес к этому предмету, сделать его как можно более радостным и увлекательным.

Ключевые слова: Русский язык, студенты, интересы, повышение, необходимое, урок, учебный процесс, вуз.

*Jabborova S.T.
teacher of the department of the uzbek language, pedagogy and physical
culture
faculty of plant protection and agro chemistry
Andijan Institute of Agriculture and Agro technologies
Uzbekistan, Andijan*

THE PROBLEM OF INCREASING STUDENTS INTEREST IN THE RUSSIAN LANGUAGE AT HIGHER SCHOOL

Abstract: Currently, this problem is relevant, since the uniformity and stereo typedness of lessons reduce interest in learning, make the educational process boring and unpromising. And in higher school, such lessons are generally unacceptable. The Russian language is one of the most difficult and by no means the most interesting subjects at higher school. Therefore, it is necessary, even in elementary school, to develop students' interest in this subject, to make it as joyful and exciting as possible.

Key words: Russian language, students, interests, to increase, necessary, lesson, educational process, higher school.

Однотипность и шаблонность уроков снижают интерес к обучению, делают учебный процесс скучным и бесперспективным. А уж в высшей школе такое проведение уроков вообще недопустимо. Русский язык является одним из сложных и отнюдь не самых интересных предметов в высшей школе. Поэтому необходимо ещё в высшей школе развить у учащихся интерес к этому предмету, сделать его как можно более радостным и увлекательным.

Развитие познавательных интересов учащихся в процессе его обучения в классах - один из важнейших факторов успешности учения, причем не только в высшей, но и в основной школе. Все усилия педагога сформировать у учащихся какое-либо представление или понятие обречено на неуспех, если учеников не удалось заинтересовать предметом рассуждения.

Интерес как явление изучается рядом наук. В психолого-педагогических исследованиях познавательный интерес определяется как потребность учащихся в знаниях, ориентирует его в окружающей действительности. Под влиянием познавательного интереса дети стараются найти новые стороны в предмете, привлекающем их внимание, пытаются установить глубокие связи и отношения между различными явлениями.

Интерес отвечает за личностный способ включения в деятельность, который ориентирует учащихся на определенное, избирательное отношение к существующим обстоятельствам.

Интерес направляет познавательную деятельность студентов. Интерес, возникающий в сознании, предшествует познанию объекта. Таким образом, интерес является не только внешним условием важности воспринимаемого, но и внутренним принципом отбора материала при восприятии.

Психолого-педагогическими исследованиями установлено, что без развития познавательного интереса развитие студентов было бы серьезно нарушено. Взаимоотношения и функции мышления так обширны, что отсутствие аффективной поддержки со стороны интереса угрожает развитию интеллекта не в меньшей степени, чем разрушение тканей мозга, считает американский психолог, автор известных книг по развитию учащихся Глен Доман. Отечественные психологи, соглашаясь с данным утверждением, подчеркивают, что интеллектуальная активность учащихся в целом направляется и подчеркивается интересом - именно он оказывает влияние на направленность внимания и мысли.

Физиологической основой познавательного интереса, по утверждению И.П. Павлова, является безусловный ориентировочный рефлекс. Однако интерес сам по себе как особое образование не существует.

Само содержание понятия «познавательный интерес» представляется исследователями по-разному: от целостных динамических тенденций, определяющих структуру реакций, до избирательного отношения и мотива.

Теория дифференциальных эмоций определяет интерес как одну из фундаментальных эмоций, которая является доминирующим мотивационным состоянием в повседневной деятельности норм человека, одним из основных компонентов мотивации.

Несмотря на разные подходы к определению познавательного интереса, попытки определить его психологическую природу приводят исследователей к выводу, что это - интегральное образование личности, включающее в себя интеллектуальный, эмоциональный и волевой компоненты. Под интеллектуальным компонентом подразумевается активность по отношению к источникам информации и возможным сферам деятельности, активное оперирование приобретенными знаниями и умениями, под эмоциональным - положительное предпочтительное отношение к объектам и явлениям действительности, а также внешние эмоциональные реакции. Подходы к выделению уровней интереса практически едины. Рассматривают следующие ступени: любопытство, любознательность, познавательный интерес, теоретический интерес. Г.И. Щукина определяет их как последовательные стадии развития, особенность которых заключается в том, что один уровень не сменяет другой последовательно. Они сосуществуют, но для каждой возрастной ступени характерно свое соотношение этих условий.

В исследовании выделяются следующие показатели развития познавательного интереса детей: появление вопросов; стремление наблюдать, длительно рассматривать объект, выяснять свойства и особенности интересующих ребенка предметов и явлений; эмоционально-познавательная активность.

При формировании интереса учитель должен руководствоваться основными правилами:

- необходимо постепенно переходить от естественных интересов к прививаемым;
- объект, предлагаемый студентам для изучения, не должен быть им совершенно новым или хорошо известным;
- материал целесообразно располагать по концентрам, «группировать его вокруг одного содержания».

Любознательность и элементарный познавательный интерес не является врожденными качествами, а любопытство само по себе есть не что иное, как реакция на новизну, и отличается большей рефлексивностью, чем любознательность, а тем более - познавательный интерес. Однако миновать стадию любопытства в развитии интереса невозможно. Поскольку сформировать теоретический интерес у студентов проблематично, то правомерно поставит задачу введения их интереса на уровень элементарного познавательного.

Для его побуждения и развития существенное значение имеет содержание знаний.

Таким образом, проблема формирования интереса к русскому языку существует.

Обучение должно быть развивающим, направленным на формирование познавательных интересов и способностей учащихся. В связи с этим особое значение приобретают игровые формы обучения, в частности, дидактические игры¹⁰⁷.

Дидактические игры предоставляют возможность развивать у учащихся произвольность таких процессов, как внимание и память. Игровые задания положительно влияют на развитие смекалки, находчивости, сообразительности. Многие игры требуют не только умственных, но и волевых усилий: организованности, выдержки, умения соблюдать правила игры¹⁰⁸.

Главное чтобы игра органически сочеталась с серьезным, напряженным трудом, чтобы игра не отвлекала от учения, а, наоборот, способствовала интенсификации умственной работы.

Использованные источники:

1. Носирова М.К. Структура урока и ее составляющие. Международный научный журнал. Экономика и общество. № 6 (73) -с.: 2020.
2. Тиллабоева Ф.А. Подходы и принципы обучения русского языка. Международный научный журнал. Экономика и общество. № 6 (73) -с.: 2020.
3. С.Жаббарова «Значение образования и воспитания в истории Средней Азии» Международный научно-практический журнал «Современные исследования» Выпуск № 5(9), Самара, 2018.

¹⁰⁷ Носирова М.К. Структура урока и ее составляющие. Международный научный журнал. Экономика и общество. № 6 (73) -с.: 2020.

¹⁰⁸ Носирова М.К. Структура урока и ее составляющие. Международный научный журнал. Экономика и общество. № 6 (73) -с.: 2020.

*Жалолов Ш.У.
преподаватель кафедры узбекского языка,
педагогике и физической культуры
факультет защиты растений и агрохимии
Андижанского института сельского хозяйства и агротехники
Узбекистан, г. Андижан*

РАЗЛИЧНЫЕ ПОДХОДЫ К КОНТРОЛЮ И ОЦЕНКЕ УЧЕБНОЙ ДЕЯТЕЛЬНОСТИ СТУДЕНТОВ

Аннотация: Контроль означает выявление, установление и оценивание знаний учащихся, т. е. Определение объема, уровня и качества усвоения учебного материала, выявление успехов в учении, пробелов в знаниях, навыках и умениях у отдельных учащихся и у всего класса для внесения необходимых корректив в процесс обучения, для совершенствования его содержания, методов, средств и форм организации.

Ключевые слова: контроль, методы, процесс обучения, организация, знания, умения, усвоение, обучение.

*Jalolov Sh.U.
teacher of the department of the uzbek language, pedagogy and physical
culture
faculty of plant protection and agro chemistry
Andijan Institute of Agriculture and Agro technologies
Uzbekistan, Andijan*

DIFFERENT APPROACHES TO CONTROL AND EVALUATION OF STUDENTS 'LEARNING ACTIVITY

Annotation: Control means identifying, establishing and assessing the knowledge of students, i.e., determining the volume, level and quality of assimilation of educational material, identifying success in learning, gaps in knowledge, skills and abilities among individual students and the whole class to make the necessary adjustments in the learning process, to improve its content, methods, means and forms of organization.

Key words: control, methods, learning process, organization, knowledge, skills, assimilation, learning.

Основная задача контроля - выявление уровня правильности, объема, глубины и действительности усвоенных учениками знаний, получение информации о характере познавательной деятельности, об уровне

самостоятельности и активности учащихся в учебном процессе, определение эффективности методов, форм и способов их учения.

Выполняя функцию руководства учебно - познавательной деятельностью учащихся, контроль не всегда сопровождается выставлением оценок. Он может выступать как способ подготовки учащихся к восприятию нового материала, выявления готовности учеников к усвоению знаний, навыков и умений, их обобщению и систематизации. Контроль имеет важное образовательное и развивающее значение.

Педагогические функции контроля состоят в выявлении недостатков в работе учащихся, установлении их характера и причин с целью устранения этих недостатков. Учителю важно иметь информацию как об усвоении учеников знаний, так и о том, каким путем они добыты.

Контроль выполняет так же большую воспитательную роль в процессе обучения. Он способствует повышению ответственности за выполняемую работу не только учащегося, но и учителя. Приучению школьников к систематическому труду и аккуратности в выполнении учебных заданий.

Исходя из основных целей развивающегося образования можно сформулировать три принципиальных положения по вопросу контроля и оценки учебной деятельности учащихся.¹⁰⁹

Педагогическая деятельность учителей на этапе с I по IV классы направлена на формирование у учащихся умения учиться, которое включает в себя два действия.

1) умение ребенка на разных этапах обучения (вначале совместно с учителем, потом в кооперации со сверстниками, затем индивидуально) определять границу свое незнание.

2) делать содержательный, целенаправленный «точечный» запрос к различным источникам знаний (к взрослым, к сверстникам и т.п.) для ликвидации своего незнания.

Для реализации этого очень важного с нашей точки зрения, умения необходимо сосредоточить работу учителей при поддержке родителей на формировании способностей у детей к взаимно - и самоконтролю, взаимно - и самооценке. Отсутствие этих учебных действий со стороны детей приводит к разрушению всей учебной деятельности. Она превращается в формальный «фарс», не дающий конечного результата.

Как правило, в традиционной школе действие контроля и оценки принадлежит исключительно к компетенции педагогов. При этой ситуации у учащихся нет мотивов к выполнению этих действий (зачем проверять диктант, все равно его будет проверять и оценивать учитель»). К тому же по традиции учащийся не владеет инструментом (критериями) контроля и оценки . (им никто этого не дает, зачем создавать себе головную боль»? Если

¹⁰⁹ Мунинова Н.М. Общие вопросы методики преподавания русского языка как иностранного на начальном этапе обучения. Международный научный журнал. Экономика и социум. № 6 (73) -с .: 2020.

дать в руки ученика «инструмент» учителя, еще неизвестно, к чему это может привести ?!)

Наша задача последовательно, системно вести работу на формирование учащимися «своего инструмента» для контроля и оценки своих действий. С этой целью в системе развивающего обучения разработаны специальные уроки, направленные на формирование контрольных и оценочных действий ребенка.

Контроль и оценка со стороны учителя за деятельностью каждого ученика присутствует в обязательном порядке от традиционной школы, у нас они имеют ряд особенностей:

- контроль и оценка в нашей системе направлены (и это очень важно !) на выявление определенного результата в предметных знаниях и умениях, но прежде всего на процесс формирования этого предметного знания у учащихся для обеспечения целенаправленной и своевременной коррекции;

- что же касается самого понятия предметных знаний, то оно рассматривается исключительно с трех позиций: системности знания, обобщенности знания и предметности знания;

- контроль и оценка деятельности учащегося рассматривается только в динамике относительно предыдущих «успехов» ребенка и не подразумевает сравнения его с другими детьми;

- в первую очередь педагогические действия контроля и оценки направлены на выявление уровня сформированности учебной деятельности у ребенка на разных этапах обучения, а также на процесс формирования общих способностей ребенка (к рефлексам, к планированию, анализу);

- при проведении контроля за деятельностью учащихся в нашем понимании ребенок сам определяет уровень своих потенциальных возможностей и выбирает те задания, с которыми на сегодняшний день он может справиться, поэтому оценка работы ученика определяется, исходя из выбранного им самим уровня сложности задач.

На основе данных особенностей в системе развивающего обучения разработана система принципиальных положений по построению контрольных, проверочных, тестовых работ вне зависимости от учебного предмета, с учетом «уровней» потенциальных возможностей детей.¹¹⁰

Использованные источники:

1. Муминова Н.М. Общие вопросы методики преподавания русского языка как иностранного на начальном этапе обучения. Международный научный журнал. Экономика и социум. № 6 (73) -с .: 2020.

¹¹⁰ Муминова Н.М. Общие вопросы методики преподавания русского языка как иностранного на начальном этапе обучения. Международный научный журнал. Экономика и социум. № 6 (73) -с.: 2020.

2. Муминова Н.М. Общие вопросы методики преподавания русского языка как иностранного на начальном этапе обучения. Международный научный журнал. Экономика и социум. № 6 (73) -с.: 2020.
3. Энциклопедия переводческих исследований Бейкер М. Рутледж, 2001.
4. Чемберлен Л. Гендерная метафорика в переводе, с. 93, Энциклопедия переводоведения Рутледж, 2001.

*Жамолов А.Т.
ведущий специалист*

Госкомгеология РУз

Хакбердийев Х.М.

студент магистратуры

ТГТУ

геолог

АО Уранредметгеология при Госкомгеологии РУз

Набийев Т.У.

студент магистратуры

ТГТУ

Туляев Ф.М.

студент магистратуры

ТГТУ

ИНЖЕНЕРНО-ГЕОЛОГИЧЕСКАЯ КЛАССИФИКАЦИЯ БУРОВЫЕ РАСТВОРЫ ДЛЯ БУРЕНИЯ

Аннотация: Для каждого вида бурения необходимо использовать определенные виды растворов. Один и тот же раствор недопустимо применять во всех видах бурения. Чем сложнее устроена скважина, и чем сложнее геологические условия бурения, тем сложнее и качественней должен быть буровой раствор. Для предотвращения аварий в процессе бурения, необходимо тщательней разрабатывать сам буровой раствор, и компоновать специальные химические реагенты.

Ключевые слова: буровых растворов калиевые глицериновые Полимерсолевые, гидрогели солей, азрированные Понижители фильтрации, Регуляторы щелочности, деэмульгаторы, реагенты, связывающие ионы кальция и магния, пеногасители, смазочные добавки, эмульгаторы.

Jamolov A.T.

Leading specialist

of the State Committee for Geology of the Republic of Uzbekistan

Hakberdiyev X.M.

master's student

of TSTU

geologist

of JSC «Uraniumrametgeology» under the State Committee

for Geology of the Republic of Uzbekistan

Nabiyev T.U.

master's student

of TSTU

ENGINEERING-GEOLOGICAL CLASSIFICATION OF DRILLING FLUIDS FOR DRILLING

Abstract: For each type of drilling, it is necessary to use certain types of solutions. The same solution is not allowed to be used in all types of drilling. The more complex the well is, and the more complex the geological conditions of drilling, the more complex and better the drilling fluid should be. To prevent accidents during drilling, it is necessary to carefully develop the drilling fluid itself, and to arrange special chemical reagents.

Keywords: drilling fluids, salt hydrogels, aerated filtration reducers, alkalinity Regulators, demulsifiers, reagents that bind calcium and magnesium ions, defoamers, lubricants, emulsifiers.

Отечественный и зарубежный опыт показывает, что только высокое качество буровых растворов позволяет наиболее полно использовать технические возможности долот и забойных двигателей, улучшить срок их службы, повысить скорость бурения, улучшить качество вскрытия продуктивных пластов, сократить затраты на борьбу с осложнениями и снизить стоимость бурения в целом [1-7]. При бурении скважины растворы выполняют множество различных функций, такие как:

- перенос энергии от насоса к забойному двигателю;
- размыв породы на забое скважины (гидромониторный эффект);
- отвод тепла от долота на забое скважины;
- предотвращение проникновения в ствол газа, нефти и воды из пластов, образующих стенки скважины;
- удержание частиц вырубленной породы;
- сохранение целостности стенок скважины, сложенных слабосцементированными породами;
- уменьшение проницаемости стенок скважины;
- уменьшение трения бурильных и обсадных труб о стенки скважины и т.п.

Цель исследования: исследовать назначение буровых растворов и химические реагенты для их приготовления. При написании контрольной работы были использованы следующие методы и приемы: монографический метод, ретроспективного анализа, группировки и т.д [8-12].

Классификация буровых растворов. Буровые растворы. Класс бурового раствора Тип бурового раствора:

1. Глинистые и меловые растворы общего назначения
2. естественные пресные и слабоминерализованные нестабилизированные
3. средне - и высокоминерализованные нестабилизированные
4. пресные и слабоминерализованные стабилизированные
5. средне - и высокоминерализованные стабилизированные
6. растворы для многолетнемерзлых пород
7. карбонатно-глинистые,
8. Глинистые растворы специального назначения
9. известковые
10. гипсовые
11. хлоркальциевые
12. мало силикатные
13. калиевые
14. глицериновые
15. малоглинистые
16. недиспергирующие малоглинистые
17. Без глинистые
18. недиспергирующие
19. полимер солевые
20. растворы электролитов (солей)
21. гидрогели солей
22. Вода Растворы на углеводородной основе
23. известковое - битумные
24. инертные эмульсии
25. Газообразные аэрированные пены
26. воздух

Ни один из известных буровых растворов не отличается универсальностью, т.е. не может успешно выполнять все перечисленные функции одновременно, поэтому применяются различные растворы, отличающиеся составом, свойствами и областью применения. Существует множество различных классификаций буровых растворов, каждая из которых имеет свои преимущества и недостатки [14-19]. То же самое можно сказать и о названиях растворов, которые многие авторы определяют по типу вводимого полимера или понизителя вязкости, например, полимер глинистый, лигносульфонатный и т.д., что совершенно не оправдано, так как они входят в состав большинства растворов на водной основе. Поэтому целесообразно название раствора определять по его наиболее характерному признаку, отражающему наличие специальных добавок, позволяющих успешно бурить в осложненных условиях. Автором в конце 1970-х годов разработана простая классификация, которая понятна даже малоопытным специалистам, несвязанным с буровыми растворами, и которая показана. Как видно из приведенной классификации, в первом классе буровых

растворов общего назначения сгруппированы растворы, оказывающие примерно одинаковое влияние на механическую скорость бурения и проходку на долото, второй класс представлен, в основном, глинистыми растворами ингибированного типа и т.д. Ниже кратко описаны условия эксплуатации, состав, наиболее оптимальная область применения и методы регулирования параметров буровых растворов.

Параметры растворов. *Условная вязкость T* - характеристика гидравлического сопротивления бурового раствора прокачиванию - продолжительность в секундах истечения 500 см^3 бурового раствора из залитых в стандартную воронку 700 см^3 . Перед изменением раствор должен быть интенсивно перемешан для разрушения структуры. При отборе раствора непосредственно из желоба и незамедлительном измерении перемешивание не требуется.

Продолжительность истечения воды из вискозиметра - *водяное число*, равное 15 с. Большая величина свидетельствует о засорении трубки и необходимости очистки, меньшая - о непригодности прибора.

Показатель фильтрации бурового раствора Φ измеряется в мл и характеризует способность бурового раствора отфильтровать через стенки ствола скважины жидкую фазу под влиянием перепада давления и образовывать фильтрационную корку различной проницаемости.

Содержание песка характеризует степень загрязнения бурового раствора грубодисперсными фракциями различного минерального состава. *Песком Π* считается все грубодисперсные частицы, находящиеся в буровом растворе, независимо от их происхождения. *Отмытый песок ОП-* это только песчаные частицы, не способные распускаться в воде.

Фильтрат буровых растворов анализируют, для чего его набирают путем отфильтровывания с помощью воронки Бюхнера (вакуумная фильтрация), снабженной бумажным фильтром [15]. Для химически обработанных растворов диаметр фильтра вследствие малой водоотдачи их должен быть не менее 75 мл. *Содержание водорастворимых солей* определяют приблизительно, т.к. в эту величину включается содержание едкого натра и органических регентов.

Химические реагенты для приготовления буровых растворов. Химические реагенты впервые начали применять в 30-х годах XX века. В настоящее время в России выпускается постоянно или периодически около 150 материалов и реагентов, часть из которых производится специально для бурения, крепления и испытания скважин. Остальные поставляются другими отраслями промышленности или являются отходами производства (для сравнения в США выпускается около 800, Канаде около 600 наименований материалов и химреагентов). Все химические реагенты разделяют по наиболее распространенным группам:

- по действию на свойства буровых растворов: понизители фильтрации, вязкости, пептизаторы, структурообразователи, пеногасители и т.д.;
- по отношению к действию солей: солестойкие и несолестойкие;
- по отношению к действию температуры: термостойкие и нетермостойкие (до 50°C)
- Реже применяются понятия - термосолестойкие и нетермосолестойкие, органические, неорганические и элементоорганические и т.д.
- Все предлагаемые классификации применяемых в бурении химреагентов либо условны, либо не имеют практической значимости. Так некоторые понизители фильтрации снижают вязкость и структурно-механические свойства, а понизители вязкости - фильтрацию (частично), одни усиливают смазочное действие нефти, другие - наоборот и т.д [17].

Понизители фильтрации. Большинство понизителей фильтрации относится к полимерам с достаточно гидрофильной поверхностью, представляющих собой анионоактивные полиэлектролиты природного (крахмал, смолы), полусинтетического (производные крахмала и К. МЦ) и синтетического (акрилаты) происхождения, обладающие в жидком виде псевдопластичными (тиксотропными) свойствами, т.е. при увеличении сдвигаемых напряжений происходит снижение вязкости. Макромолекулы веществ, состоящие из многочисленных элементарных звеньев (мономеров) одинаковой структуры называются *полимерами*, а из разнородных звеньев - *сополимерами*. При этом их атомы связаны прочной химической (ковалентной) связью, а молекулярная масса составляет от 5000 до 1000000 и более.

Реагенты на основе акриловых полимеров. Гипан - гидролизированный полиакрилонитрил - впервые применен в 1949 г. (США), в России в 1961 г. для снижения фильтрации пресных, известковых, слабоминерализованных растворов. При получении гипана выделяется запах аммиака, отсутствие которого предопределяет проверку качества гипана в лабораторных условиях. Гипан представляет собой вязкую темно-желтоватую жидкость 8-10% -ной концентрации с плотностью 1.05-1.07 г/см³, рН = 12 и более или порошок желтоватого, кремового или розового цвета с влажностью 10%, который можно применять в товарном виде или в виде раствора 10% -ной концентрации [18]. Гипан совместим с другими понизителями фильтрации, при этом эффективность комбинированной обработки значительно выше, чем каждого реагента в отдельности.

Метакрил - 14 (М - 14) представляет собой сополимер метакриловой кислоты и метилметакрилата. Выпускается в виде мелкогранулированного порошка и предназначен для снижения фильтрации пресных, высокоминерализованных, малоглинистых растворов.

Понизители вязкости (пептизаторы). При использовании буровых растворов часто наблюдается рост вязкости и предельного статического

напряжения сдвига (ПНС), в основном, из-за наличия высокого содержания глинистой фазы, электролитов и повышенной температуры, а также дополнительной пептизации глинистых частиц химическим путем, механического диспергирования и образования осадка при связывании ненужных катионов. За рубежом выпускаются понизители вязкости на основе акриловых полимеров с низкой молекулярной массой, устойчивых к температуре до 150°C, причем их расход в 40 раз меньше лигносульфатных разжижителей. Краткая информация о понизителях вязкости изложена ниже.

Лигносульфонат технический или сульфит-спиртовая барда (ССБ) впервые предложен в 1937 г. (Россия) и является многотонажным отходом целлюлозно-бумажной промышленности, представляющим собой кальциевые, натриевые и аммонийные соли лигносульфоновых кислот. Так как ССБ имеет кислую реакцию, то она может использоваться как регулятор щелочности, а также для предотвращения солевой и температурной флокуляции бентонита. Еще важным назначением ССБ является ее использование для залавки скважин во время капитального ремонта вместо пластовой воды, что позволяет сохранить проницаемость пласта и его нефтеотдачу [19, 20].

Феррохромлигносульфонат (ФХЛС) получают путем обработки ССБ сернокислым железом и бихроматом натрия; впервые применен в 1955 г. (США). ФХЛС представляет собой порошок коричнево-зеленого цвета, хорошо растворяющийся в воде и предназначен для снижения вязкости и частично фильтрации пресных и среднеминерализованных растворов. ФХЛС затормаживает процесс гидратации глинистых пород, и увеличивает их период набухания, вспенивает буровой раствор при добавке 1% и более. Но главным достоинством ФХЛС является его способность снижать вязкость гипсовых растворов. Ни один из существующих понизителей вязкости не обладает этим свойством.

Декстрин является отходом производства крахмала и представляет собой светло-коричневый порошок, хорошо растворимый в воде. Реагент применяется для снижения вязкости и частично фильтрации пресных и минерализованных буровых растворов при добавке порошкообразного 2%, а в виде водно-щелочного раствора 10: 2, 3-8%.

Регуляторы щелочности. *Каустическая сода* (гидроксид натрия - NaOH) представляет собой бесцветную, непрозрачную кристаллическую массу плотностью 2.13 г/см³, рН = 16.5, хорошо растворяющуюся в воде, особенно при повышенной температуре, с большим выделением тепла, а также в виде раствора 43-47% -ной концентрации по ТУ 2132-185-00203312-99. На воздухе NaOH поглощает влагу и углекислый газ, превращаясь в кальцинированную соду, при этом на поверхности щелочи образуется корка. NaOH применяется с 1929 г. (США) во всех буровых растворах на водной основе, для приготовления химреагентов УЩР, крахмального

клейстера, нитролигнина, акрилатов, ССБ и др., а также для снижения растворимости извести в известковых растворах, противодействия коррозии и нейтрализации H_2S . Небольшая добавка щелочи (до 0.2% на сух.) вызывает временное диспергирование глинистых частиц, увеличение электрокинетического потенциала и незначительно влияет на вязкость бурового раствора [21].

Гидроксид калия (КОН) представляет собой белые чешуйки или гранулы с плотностью 2.04 г/см, рН = 16.8 в соответствии с ТУ 6-18-50-86. Применяется для повышения рН и частичного носителя иона K^+ в калиевых буровых растворах, приготовления химреагентов и жидкости затворения при цементировании ММП.

Для повышения рН применяются также кальцинированная сода, фосфаты (в пресных растворах); известь; бура при температуре 120°C и более; жидкое стекло; органические соединения, например, амины, которые при взаимодействии с поливалентными металлами образуют нерастворимые в воде, но химически активные мыла; оксид магния (MgO) в безглинистых растворах и др.

Ингибиторы термоокислительной деструкции. Термостойким считается буровой раствор, в котором сохраняется полученная ранее менее 10 см³/30 мин. Фильтрация, при его циркуляции в скважине в течение не менее 4-5 суток. Однако при повышенных и высоких температурах, особенно при наличии минерализации, происходит коагуляция и глобулизация глинистых частиц со снижением их гидрофильности, термоокислительная деструкция реагентов, снижение вязкости фильтрата и его высвобождение, что приводит к быстрой порче всех параметров бурового раствора. Для предупреждения этих явлений используются различные способы и в первую очередь применение ингибиторов термоокислительной деструкции.

Хроматы и бихроматы натрия и калия являются натриевыми или калиевыми солями хромовой и бихромовой кислоты и представляют собой порошок желтого (хроматы) и оранжевого (бихроматы) цвета, хорошо растворимые в воде. Они предназначены для повышения стабилизирующей способности защитных реагентов, снижения рН и вязкости буровых растворов и частичного предотвращения глобулизации глинистых частиц при повышенных температурах [22]. Сами по себе хроматы (бихроматы) не улучшают свойства буровых растворов, поэтому обязательными условиями применения хроматов являются наличие в растворе температуры более 70 С и органических химреагентов - восстановителей, которые взаимодействуя с хроматами, способствуют интенсификации процессов обмена и замещения.

Реагенты, связывающие ионы кальция и магния. *Карбонат натрия, кальцинированная сода* Na_2CO_3 представляет собой белый мелкокристаллический порошок с $\rho = 2.533$ г/см³, рН = 11.2 и применяется, в основном, для удаления агрессивных ионов кальция и магния,

попадающих в раствор с пластовыми водами, гипсом, ангидритом и цементом, а также для повышения рН пресных буровых растворов, приготовления некоторых химреагентов, буровых растворов из глини кальциевого типа (пептизатор), увеличения выхода раствора (меняется обменный комплекс) и снижения жесткости воды.

Пеногасители. Основными причинами вспенивания буровых растворов являются:

- поступление газа в раствор при разбурировании газовых и газоводонефтяных горизонтов, а также вследствие снижения гидростатического давления на пласт, эффекта поршневания и диффузии;
- физико-химическое взаимодействие буровых растворов с различными солями, содержащимися в частицах выбуренных пород или пластовых водах, а также при их обработке пенообразующими реагентами, снижающими поверхностное натяжение воды; следует учесть, что ценообразование получается только от свободного (избыточного) реагента-пенообразователя, не адсорбированного глинистой (твердой) фазой, причем более интенсивное в минерализованных растворах;
- введение порошкообразных материалов;
- негерметичность отдельных элементов обвязки насосов;
- гидродинамическое несовершенство циркуляционных систем, под которым понимается наличие различных механических возбудителей и турбулизация раствора.

Альфонол-79 (П-79) представляет собой смесь синтетических высших жирных спиртов, в состав которой входят спирты с длиной углеродной цепи 7-9 атомов. Применяется в качестве пеногасителя пресных и высокоминерализованных буровых растворов при температуре до 90°C и добавке 0.5-1.0% в виде 2% -ного раствора в дизельном топливе, что в пересчете на сухое вещество в 10 раз меньше расхода сивушного масла. Выпускается в виде жидкости с $\rho = 0.83 \text{ г/см}^3$ с температурой замерзания -5°C.

Стеарат алюминия представляет собой смесь синтетических высших жирных спиртов и применяется в качестве пеногасителя пресных и высокоминерализованных растворов при добавке 0.5% в виде 10% -ного раствора в дизельном топливе. Выпускается в виде твердого вещества нефтехимическими предприятиями г. Дзержинска, Нижегородской обл. и г. Салават, Башкортостан

Смазочные добавки. Смазочные добавки предназначены для уменьшения крутящего момента колонны бурильных труб, увеличению стойкости трущихся металлических пар и предотвращению прихватов. Влияние этих добавок на повышение стойкости опор долота заключается в гидрофобизации трущихся поверхностей и ингибировании коррозионных процессов с образованием на поверхности трения смазочных пленок,

способствующих устранению микрошероховатостей и снижению удельных нагрузок.

Нефть представляет собой маслянистую жидкость от черного до светло-коричневого цвета со специфическим запахом, которая содержит 83-87% углерода. В качестве смазывающей добавки лучше использовать нефти (впервые применена в 1937 г, США) с нормальной плотностью, малым газовым фактором, малопарафинистую, малосернистую и смолистую[23]. Нефть совместима со всеми буровыми растворами, причем, чем выше его плотность, тем больше потребность в нефти. К недостаткам нефти относятся: высокая температура замерзания (от - 10 до +5°C в зависимости от содержания парафина), низкие противоизносные свойства, недопустимый расход стратегического сырья, высокая пожароопасность.

Графит - кристаллический порошок серебристого цвета, гидрофобен, не растворим в воде. Смазывающий эффект на 50% меньше, чем нефти, а противоизносные свойства также невелики. Однако при комбинации 1% графита и 10% нефти эффект значительно усиливается, чем каждой добавки в отдельности.

Эмульгаторы. Основными эмульгаторами являются мыла жирных, нафтеновых и сульфонафтеновых кислот, анионоактивные и неионогенные ПАВ, смазочные добавки (сульфонол, аловое масло, эмульта, полиэтиленмин и др.). Краткая информация об эмульгаторов изложена ниже.

Сульфонол НП-1 - представляет собой синтетическое ПАВ, анионоактивного типа в виде порошка, хорошо растворим в воде с образованием обильной пены и в нефти, а в растворе NaCl с концентрацией больше 12% и в пластовой воде выпадает в осадок.

Полиэтиленэмин (ПЭИ), представляет собой светло-коричневый порошок кальций-магниевых мыл смеси предельных, непредельных углеводородов и смоляных кислот, включающий свободные оксиды кальция и магния. Изготавливается на основе таллового пека (отход целлюлозно-бумажной промышленности) путем его обработки 50% -пой водной суспензией оксидов кальция и магния. Применяется в качестве эмульгатора буровых растворов (взамен эмульта), а также эффективного флокулянта твердой фазы. ПЭИ выпускает ОАО "Братский ЛПК", г. Братск., Иркутская обл.

Деэмульгаторы. Деэмульгаторы предназначены для разрушения водонефтяных эмульсий и выделения воды из нефти, при этом снижаются вязкость и гидравлические потери. Все деэмульгаторы представляют собой смесь блоксополимеров оксида этилена и пропилена различной молекулярной массы и различного соотношения оксидов в блоке, растворенные в органическом растворителе. *Оксифос Б, Б-1, Б-1М* представляет собой вязкую непрозрачную жидкость от бесцветного до коричневого цвета с $\rho = 1.065 \text{ г/см}^3$, хорошо растворяющуюся в воде, имеет

pH 6-8, расход 50-300 г/т. Выпускается ОАО "Химпром", г. Новочебоксарск, Чувашская республика и ОАО "Нефтемаслозавод", г. Оренбург.

Диссолван представляет собой светлую, прозрачную жидкость с $\rho=0.95$ г/см с массовой долей активного вещества 65 %, растворим в воде. В товарном виде легко смешивается с нефтью при его расходе 30-200 г/т. Водные растворы 0.5-3% -ной концентрации не реагируют с солями, слабыми щелочами и кислотами. Расход диссолвана как эмульгатора в растворах на водной основе составляет 0.1-0.5 %. Реагент относится к неионогенным ПАВ, пожароопасен, выпускается в Германии.

Поверхностно-активные вещества. По названию веществ можно сразу определить место, где они себя проявляют - на поверхности фаз. ПАВ называются вещества, способные снижать поверхностное натяжение на границе жидкой или твердой поверхности раздела фаз, вследствие их положительной адсорбции, а также капиллярного давления в порах пласта.

По содержанию гидрофильных групп и химическим свойствам ПАВ подразделяется на 2 класса: *ионогенные* и *неионогенные*.

Неионогенные ПАВ применяются для сохранения проницаемости при вскрытии продуктивных пластов, в качестве гидрофобизаторов глинистых пород и гид-рофилизаторов кварца, эмульгаторов нефти, и деэмульгаторов воды, повышения термостойкости химреагентов и буровых растворов, понизителя твердости горных пород при промывке водой и карбонатно-глинистыми растворами.

Итак, на основе всего выше изложенного можно говорить о том, что данная тема является актуальной, т.к. буровые растворы используются в самых разнообразных горно-геологических условиях, при этом на их физико-механические свойства оказывают влияние порознь или совместно температура, давление, электролиты, стабильность, контракция, скорости сдвига, режим течения и др. Поэтому точно описать или исследовать поведение буровых растворов в скважине практически невозможно, так как их свойства меняются даже в течении одного цикла циркуляции.

Использованные источники:

1. Городнов В. Д. Буровые растворы: Учебник для техникумов. – Недра, 1985.
2. Латкин А. Н. Обслуживание и ремонт буровых установок //М:«Недра»–1985г.–320 с.
3. Михеев В. Л. Технологические свойства буровых растворов. – Недра, 1979. - 239 с.
4. Паус К. Ф. Буровые растворы //М.: Недра. – 1973. – Т. 304.
5. Подгорнов Ю.М. Эксплуатационное и разведочное бурение на нефть и газ: Учеб. пособие для рабочих на производстве. - М.: Недра, 1988. - 325 с.: ил.
6. Резниченко И.Н. Приготовление, обработка и очистка буровых растворов / И.Н. Резниченко. - М.: Недра, 1962. - 230 с.

7. Рябоконт С. А. Утяжелители для буровых растворов и технология их приготовления / С.А. Рябоконт. - М.: Недра, 1981. - 239 с.
8. Рязанов. Я.А. Энциклопедия по буровым растворам / Я.А. Рязанов. - Оренбург: изд. "Летопись", 2005. - 664 с.
9. З.Н.Бабаев,А.А.Умирзоков, А.Н.Караманов, Ю.Э.Петросов. Техно-экономическое обоснование кондиций для подсчета запасов горючих сланцев месторождения Сангрунтау// Студенческий вестник научный журнал, №10 (108), часть 2, Москва 2020,Ст.18-21.
10. Nasirov U. F. Ochilov Sh. A., Umirzoqov A. A. Analysis of Development of Low-Power and Man-Made Gold Deposits //International Journal of Academic and Applied Research (IJAAR) ISSN. – С. 2643-9603.
11. Umirzoqov A. A., Jurayev S. J. Karamanov A. N. Economic and mathematical modeling of rational development of small-scale and man-made gold deposits //International Journal of Academic and Applied Research (IJAAR). – 2020. – Т. 4. – №. 4. – С. 75-77.
12. Hayitov O. G. et al. Prospects for the industrial use of coal in the world and its process of reproducing //Novateur Publication's JOURNALNX-A Multidisciplinary Peer Reviewed Journal. – 2020. – Т. 6. – №. 5. – С. 240-247.
13. Kazakov A. N. et al. Assessment of the Stress-Strain State of a Mountain Range //International Journal of Academic and Applied Research (IJAAR). – 2020. – Т. 4. – №. 6. – С. 17-21.
14. Nasirov U. F. Ochilov Sh. A., Umirzoqov AA Theoretical Calculation of the Optimal Distance between Parallel-close Charges in the Explosion of High Ledges //Journal of Advanced Research in Dynamical and Control Systems–JARDCS. – Т. 12. – С. 2251-2257.
15. Umirzoqov A. A. Karamanov A. N., Radjabov Sh. K. Study of the feasibility of using intermediate buffer temporary warehouses inside the working area of the Muruntau quarry //International Journal of Engineering and Information Systems (IJEAIS). – 2020. – Т. 4. – №. 8.
16. G'afurovich K. O., Abdurashidovich U. A., Ogli B. A. O. Small Torch Progress In Prospects Gold Mining In Improving Countries //The American Journal of Interdisciplinary Innovations and Research. – 2020. – Т. 2. – №. 09. – С. 65-72.
17. Sultonovich M. M. et al. Technology Of Modified Sodium-Aluminum Catalysts For Nitrogen Gas Purification Systems //The American Journal of Applied Sciences. – 2020. – Т. 2. – №. 09. – С. 154-163.
18. Djurayevich K. K. et al. Complex Processing Of Lead-Containing Technogenic Waste From Mining And Metallurgical Industries In The Urals //The American Journal of Engineering and Technology. – 2020. – Т. 2. – №. 09. – С. 102-108.
19. Хайитов О., Умирзоков А., Равшанов З. Анализ текущего состояния и пути повышения эффективности разработки нефтегазовых месторождений

юго-восточной части бухаро-хивинского региона //Материалы конференций МЦНД. – 2020. – С. 8-11.

20. Хайитов О., Умирзоков А., Бекмуродов А. О применении методов подсчета запасов газа в месторождении северный гузар //Збірник наукових праць ЛОГОС. – 2020. – С. 56-59.

21. G'ofurovich K. O. et al. Justification Of The Need For Selective Development Of The Phosphorite Reservoir By Horizontal Milling Combines //The American Journal of Engineering and Technology. – 2020. – Т. 2. – №. 11. – С. 159-165.

22. Abdurashidovich U. A. The Condition Of General Development Of The Mineral Resource Base In Uzbekistan //The American Journal of Applied sciences. – 2020. – Т. 2. – №. 12. – С. 1-6.

23. Яров А. Н., Жидовцев Н. А., Гильман К. М. Буровые растворы с улучшенными смазочными свойствами //М.: Недра. – 1975.

*Зульбухарова А.А., магистр
кафедры лесного хозяйства
Ташкентский государственный аграрный университет
Каландаров М.М.
профессор кафедры лесного хозяйства
Ташкентский государственный аграрный университет*

ВЫРАЩИВАНИЕ ПЛОСКОВЕТОЧНИКА ВОСТОЧНОГО В БОТАНИЧЕСКОМ САДУ Г.ТАШКЕНТА

*Аннотация: Статья весьма актуально, в них изложена агротехнические мероприятия для выращивания сеянцев, декоративного растения плосковеточника восточного (*Platycladus orientalis*) с семенами в условиях открытого грунте. Проводили лесоводственную работу в рядах и между рядами, обеспеченно вовремя поливами и минеральными удобрениями. Данный момент сеянцы плосковеточника восточного растут нормально. Проводили таксационные измерения по высоте по диаметру.*

Ключевые слова: специфический, дикорастущий, онтогенез, мульчируют, прорастания, сопутствуют

*Zulbukharova A.A., master
of the Department of Forestry
Tashkent State Agrarian Universitet
Qalandarov M.M.
Professor Head of the Department of Forestry
Tashkent State Agrarian Universitet*

GROWING PLATYCLADUS ORIENTALIS IN TASHKENT BOTANIC GARDEN

*Annotation: The article is very relevant; it sets out agrotechnical measures for growing seedlings of the ornamental *Platycladus orientalis* with seeds in open soil conditions. We carried out silvicultural work in rows and between rows, it is provided watering and mineral fertilizing on time. At this moment, the seedlings of the *P. orientalis* grow normally. Taxation measurements were carried out in terms of height along the diameter of the *P. orientalis* one in the trial plots of the experiment. After that, we carry out agrotechnical measures in the experimental area.*

Keywords: specific, wild-growing, ontogenesis, mulch, germination, accompany

Актуальность темы. В современных условиях роста городов, связанного с промышленным развитием и интенсивным движением автотранспорта, немаловажное значение приобретают вопросы охраны окружающей среды. Основные факторы неблагоприятного воздействия городской среды на человека и растения – загрязненность воздушного и водного бассейнов, специфический микроклимат, часто усиливающий негативные природные факторы и чрезмерные шумы.

Известно, что большинство хвойных древесных пород неустойчивы в экстремальных условиях городской среды. Для озеленения населенных мест следует отобрать виды хвойных с высокими санитарно - гигиеническими качествами, устойчивые к антропогенным воздействиям. К таким растениям относится плоскоцветник восточный (*Platycladus orientalis* Endl.). Изучение биологических особенностей этого вида в городских условиях ранее не проводилось. Естественная область распространения плоскоцветника – горы Сев. Китая (Шэн-си и Шан-си), в умеренной и холодной зимой, теплым и влажным летом, на каменистых почвах до 1000м над у.м [1]. По распространению плоскоцветника в природе имеется ряд суждений. Одни авторы (С.И.Кузнецов,1984; А.Л. Липа, 1977) считают, что ареал *Platycladus* лежит за пределами древнего Средиземье Севера Ирана и Памира. Другие (И.Т. Васильченко и Ф.Х. Джангузов.1957) говорят о том, что плоскоцветник распространен в Северном Китае, Манжурии, Корее, на Памиро-Алае. Впервые на реке Дуобе плоскоцветника обнаружил В.И. Липский (1902), во время путешествия по Гусарскому хребту В.И. Массальский (1913) отмечает, что в Средней Азии встречаются одиночные деревья. Самое крупное дерево описано на мазаре в Хужанде. При основании ствола оно имело диаметр около 4,2м. По данным Васильченко и Джангузова (1957) и Коровина (1962), плоскоцветник в диком состоянии найден на Гиссарском хребте и в Нуратинских горах на высоте 1350м над у.м. И.Т. Васильченко Ф.Х. Джангузова (1957) сообщают о том, что дикорастущий плоскоцветник найден ими в Западной. Гиссаре в бассейне реки Тупаланг на одном из правых ее притоков – Дуоба.



Рис-1. Плосковеточник произрастающий в рядовых посадках.

Ранние этапы и периоды онтогенеза семейных форм плосковеточника. Изучение онтогенеза видов и форм семейства Cupressaceae, завезенных в нашу страну, играет важную роль в полном научном обосновании этих растений. На сегодняшний день конкретных исследований онтогенеза видов и форм семейства Cupressaceae в климатических условиях Узбекистана не проводилось.

В последнее время большое внимание уделяется для выращивания декоративных хвойных пород в питомнических хозяйствах, ботаническом саду и в других хозяйствах. Семена плосковеточника бескрылые, яйцевидные, бурые со светлым пятном при основании, 5мм длиной (по форме напоминающие семена груши). Всхожесть семян высокая 80%, которую сохраняют семена 3-4 и более лет. Семеношение ежегодное с четырехлетнего возраста. Хранить семена следует в ящиках, мешках в сухих и прохладных помещениях. Выход чистых семян из сырья -10%. Все 1000 чистых семян-24г. Срок для посева-весна-осень. Семена легко прорастают без предварительной подготовки. На замочках их в воде в течение одних суток или в растворах гетероауксина марганцовки ускоряет появление всходов, повышает энергию прорастания. Норма высева - 4г на 1 п.м. Глубина заделки - 2-2,5 см. После посева гряды мульчируют опилками или мелкой соломой. Всходы появляются через 30-35 дней. Сеянцы в условиях полива растут сравнительно быстро. К концу первого года достигают 15-18 см высоты и 5-10 мм в диаметре.



Рис-2. Рост и развитие сеянцев плосковеточника

Всходы плосковеточника нежные и за ними требуется хороший уход – регулярные поливы и первое время гряды следует иногда отенять.

Прорастание семян плосковеточника в пробных участках является одним из основных показателей, определяющих воспроизводство и восстановление растений из семян, рост вида и качество семян. Всхожесть семян растений и различные факторы, влияющие на нее хорошо изучены. Семена *Platycladus orientalis* f. *compacta* крупнее семян других представителей, коричневого цвета, длиной 0,5-0,6 мм и шириной 0,2-0,3 мм. Оптимальная температура прорастания семян при комнатной температуре составляла + 20 + 22°C, всхожесть семян достигала 2% через 3 дня, 17% через 6 дней, 14% через 9 дней и 20% через 12 дней. При высоких температурах +25 +27°C устойчивость 46%, при + 27 + 28°C 7%. При максимальной установленной в опытах температуре (+ 30 + 32°C) забывчивость составила 3%.

Прорастание семян *Platycladus orientalis compacta* в лабораторных условиях. Температура - один из основных факторов прорастания семян растений. По результатам наших наблюдений было отмечено, что всхожесть семян при температуре + 30 + 32°C очень низкая. Всхожесть семян при температуре + 20 + 22°C зафиксирована на уровне 78%. Так, этот показатель оказался оптимальной температурой для *P. orientalis* f. *compacta*. Когда семена этого растения помещали в чашку петри, было замечено, что через 3 дня кожура семян разорвалась и появились опухоли толщиной 0,3-0,4 мм. Вода - один из важнейших факторов прорастания семян. Через 7–10 дней образовались две споры длиной 0,5–0,6 мм и шириной 0,2–0,3 мм, а длина опухоли (гипокотиль) достигала 0,5–0,6 мм. Через десять дней появляются два ланцетных листа длиной 1,5–2,3 см и шириной 0,2–0,3 мм. Гипокотиль

длиной 3-4,1 см, корень 0,8-1,3 см. Спустя пятнадцать дней было отмечено, что гипокотиль достигал 6,2 см в длину, а длина листа достигала 3,2 см.

Состояние прорастания компактной формы плоскочеточника в этапы прорастания семян. По мнению некоторых исследователей, в литературе, быстрая коагуляция или не свёртывание семян зависит от структуры их семенной оболочки и природы веществ, содержащихся в семенах (Иванова З.Я., с. 288).

В возрасте 1-2 х лет сеянцы плоскочеточника высаживают в школу, где их выдерживают в зависимости от назначения саженцев 1-3 года.

Наибольшая масса корней сосредоточена в верхнем горизонте почвы. Но наиболее быстрый рост отмечается у сеянцев с 3-4 х лет жизни до 7-8 летнего возраста, т.е. до начала обильного плодоношения. При поломках, подрезке крона быстро восстанавливается. Культуры плоскочеточника можно создавать на различных почвах, включая засоленные, но она не переносит уплотнения почвы. В холодные зимы у деревьев плоскочеточника наблюдается осенне-зимнее побурение хвои, но весной зеленеют, восстанавливаются. Культуры плоскочеточника в большинстве случаев сопутствуют главным породам, как сосне крымской, можжевельнику виргинскому, березе, ясеню и др.

Использованные источники:

1. Озеленительный ассортимент и уход за городскими насаждениями Узбекистана/ Л.А.Абдурахманов, Т.И. Славкина. –Т., 1980.
2. Лесные культуры Т.2009. С.М. Аблаев и Я.Х. Юлдашов.
3. Культура озеленения/ В.П. Печеницын, А.А. Азамов.– Т., 2005
5. «Размножение и выращивание декоративных древесных пород». В. И. Климович - М.1987.
6. Декоративное садоводство / Т.И. Славкина, О.И. Подольская– Т., 1987.

*Ибрагимов И.У.
доцент
Наманганский инженерно-технологический институт
Узбекистан, Наманган*

ОРГАНИЗАЦИОННО-ЭКОНОМИЧЕСКИЙ МЕХАНИЗМ УПРАВЛЕНИЯ МАЛЫМ БИЗНЕСОМ

Аннотация: В работе обсуждается механизм управления - как метод направления и организации деятельности систем управления к целям системы, отношениям, обеспечивающим функционирование организационно-экономической системы, представляет собой сочетание форм и средств. Он координирует отношения между объектом управления и субъектом. Механизм управления сформирован так, чтобы влиять на деятельность объектов.

Ключевые слова: механизм управления, бизнес организационно-экономическая система, деятельность.

*Ibragimov I.U.
Associate Professor
Namangan Engineering Technological Institute
Uzbekistan, Namangan*

ORGANIZATIONAL AND ECONOMIC MECHANISM OF SMALL BUSINESS MANAGEMENT

Annotation: The paper discusses the management mechanism - as a method of directing and organizing the activities of management systems to the goals of the system, relations that ensure the functioning of the organizational and economic system, is a combination of forms and means. He coordinates the relationship between the object of control and the subject. The control mechanism is formed so as to influence the activities of objects.

Key words: management mechanism, business, organizational and economic system, activity.

Масштабные реформы, осуществленные в нашей стране за годы независимости, стали важной основой для укрепления национальной государственности и суверенитета, безопасности и правопорядка, нерушимости государственных границ, верховенства закона, прав и свобод человека, межнационального согласия и религиозной терпимости. созданы необходимые условия для реализации творческого потенциала наших граждан.

В целях дальнейшего повышения эффективности реформ, создания условий для быстрого развития государства и общества, реализации приоритетов модернизации и либерализации всех сфер жизни, комплексное изучение актуальных вопросов, волнующих население и предпринимателей, правоохранительные органы. Утверждена Стратегия действий по пяти приоритетным направлениям развития Республики Узбекистан на 2017-2021 годы, утвержденная в результате анализа передовой практики и зарубежного опыта, а также широкого общественного обсуждения.

В частности, продолжение институциональных и структурных реформ, направленных на сокращение участия государства в экономике, защиту прав частной собственности и дальнейшее укрепление ее приоритетных позиций, стимулирование развития малого бизнеса и частного предпринимательства:

- Обеспечение надежной защиты прав и гарантий частной собственности, преодоление всех препятствий и ограничений для развития частного предпринимательства и малого бизнеса, предоставление ему полной свободы, реализация принципа «Богат народ - богатым и сильным будет государство»;

- создание благоприятной бизнес-среды для развития малого бизнеса и частного предпринимательства, строгое предотвращение незаконного вмешательства в деятельность бизнес-структур со стороны государства, правоохранительных и контролирующих органов;

- дальнейшее расширение приватизации государственной собственности и упрощение ее процедур, сокращение государственного участия в уставных фондах хозяйствующих субъектов, создание благоприятных условий для развития частного предпринимательства на основе приватизированной государственной собственности;

- совершенствование и упрощение процедур и механизмов подключения субъектов хозяйствования к инженерным сетям;

- сокращение государственного участия в регулировании социально-экономического развития страны, децентрализация и демократизация государственного управления, расширение государственно-частного партнерства, повышение роли негосударственных, общественных организаций и органов местного самоуправления.

Любая система управления работает под воздействием определенных механизмов. В экономических словарях понятие механизма рассматривается как последовательность состояний и процессов, которая сама по себе определяет действие, реальность, а также последовательность действий систем.

Механизм включает в себя определенную последовательность экономических событий: составляющими его элементами являются как входящие, так и исходящие события, а также процессы, происходящие

между ними. Механизм - это естественная система, обеспечивающая необходимое взаимодействие и коммуникацию, возникающую в результате экономических событий.

Также есть два подхода к понятию механизма:

- организационно-структурные;
- функционально-конструктивная

Организационно-структурный подход определяет механизм как набор элементов, которые служат для создания организационной основы для конкретных событий и процессов.

С другой стороны, функционально-структурный подход фокусируется не только на организационной основе его структуры, но и на ее динамике, ее реальной функциональной деятельности.

В научных исследованиях понятие механизма выражается в таких словосочетаниях, как рыночный механизм, производственный механизм, организационный механизм, экономический механизм, экономический механизм, организационно-экономический механизм. В процессе управления соблюдаются те же процессы, что и работа механизма, и цель достигается в результате работы механизма. Таким образом, механизм управления - это метод направления и организации деятельности систем управления к целям системы, отношениям, обеспечивающим функционирование организационно-экономической системы, представляет собой сочетание форм и средств. Он координирует отношения между объектом управления и субъектом. Механизм управления сформирован так, чтобы влиять на деятельность объектов.

Понятие организационно-экономического механизма часто сравнивают с понятиями экономического механизма, организационного механизма и экономического механизма. Наиболее распространенным из этих понятий, имеющим более широкий охват, является экономический механизм.

Л.И. По словам Абалкина, экономический механизм - это совокупность форм и способов работы, в которую входят не только базовые, но и взаимодействующие между собой элементы надстройки. В.А. По словам Ульянова, экономический механизм - это способ организации производства, система, которая формирует производственные отношения как форму управления (план, экономические нормы, цены, прибыль, заработная плата, финансы, кредит, принятие решений), и это не только производство. в отношениях, скорее, это организация производительных сил и структуры. Е.Е. Вершигора подчеркивает, что экономический механизм возникает в результате взаимодействия и координации планирования, экономических стимулов, рыночных механизмов и организационной структуры. Исходя из вышесказанного, можно сказать, что экономический механизм более макроопределен.

На наш взгляд, механизм управления состоит из 5 основных элементов:

- объект и субъект управления;
- цели и функции;
- органы управления и организационная структура;
- методы и принципы;
- инструменты.

Кроме того, механизм управления как сложная категория управления включает:

- цели управления (ЦУ);
- Количественный аналог (аналог) целей (SQ) - критерии управления;
- факторы управления (БО) - элементы управления и взаимосвязь между ними для достижения целей;
- методы воздействия на указанные факторы управления (ТУ);
- Управленческие ресурсы (РУ) - материальные и финансовые ресурсы, социальный потенциал.

Соответственно, конкретный механизм управления может быть описан функционально для объекта.

КБМ| (ВМ: ВК: ВО: ТУ: ВР) (1)

Согласование основных функций отдельных механизмов управления в рамках сложного механизма позволяет создать максимальную эффективность и результативность процесса управления.

Использованные источники:

1. Вебер М. Протестантская этика и дух капитализма. Пер. с немецкого. М.: Прогресс, 2010, 85-б.
2. Друкер П. Рынок: как выйти в дилеры. Практика и принципы. – М.: 2009. с. 98.
3. Хоскинг А. Курс предпринимательства. М., 2009, с.28
4. Гулямов С.С., Догиль А.Ф., Семенов Б.А. Предпринимательство и малый бизнес. – Т. 1997 – с 33 – 34.

*Ибрагимов И.У.
доцент
Наманганский инженерно-технологический институт
Узбекистан, Наманган*

РАЗВИТИЕ ИСПОЛЬЗОВАНИЯ КЛАСТЕРНОЙ СИСТЕМЫ В ЭФФЕКТИВНОМ УПРАВЛЕНИИ ХОЗЯЙСТВЕННЫМИ ОБЩЕСТВАМИ

Аннотация: Рассмотрена деятельность по созданию и развитию конкретного кластера называется кластерной инициативой. Таким образом, кластерную политику страны или региона можно рассматривать как портфель кластерных инициатив, оптимизированный с точки зрения воздействия и риска, которые возникнут в результате ее реализации.

Ключевые слова: кластер, деятельность, управлении хозяйственными, управления

*Ibragimov I.U.
Associate Professor
Namangan Engineering Technological Institute
Uzbekistan, Namangan*

DEVELOPMENT OF THE USE OF THE CLUSTER SYSTEM IN THE EFFECTIVE MANAGEMENT OF BUSINESS ENTITIES

Annotation: The activity on the creation and development of a specific cluster is considered, called the cluster initiative. Thus, the cluster policy of a country or region can be viewed as a portfolio of cluster initiatives, optimized in terms of the impact and risk that will arise as a result of its implementation.

Key words: cluster, activity, economic management, management.

Кластер (в экономике)(Англ. Кластер) - взаимосвязанные организации (компании, корпорации, университеты, банки и др.), Собранные в любом регионе. Это взаимодействие продукта, его запасных частей и специальных услуг, инфраструктуры, исследовательских институтов, университетов и других организаций, которые дополняют друг друга и повышают конкурентоспособность отдельных компаний.

Кластер обладает характеристиками обеспечения взаимной конкуренции участников, их сотрудничества, формирования и организации уникальной необратимой компетенции в регионе.

Мы можем использовать концепцию кластера как в практических, так и в практических целях. Мы можем использовать концепцию кластера для двух целей:

В первом случае кластер выступает как альтернатива независимой организации или отраслевому объекту исследования и как прогноз.

Во втором случае кластер можно рассматривать как объект поддержки разработчиков стратегии развития региона с учетом производительности, инноваций, конкурентоспособности, производительности и занятости фирм в любом регионе.

Описательные особенности кластера следующие:

- максимальная географическая близость;
- схожесть технологий;
- общность сырьевой базы;
- наличие инноваций.

Действия, направленные на поддержку кластеров, называются кластерными политиками и включают:

- инновации удаление относительно установленных барьеров;
- инвестиции в человеческий капитал и физическую инфраструктуру;

- поддержка географически связанных центров.

Кластерные инициативы формируются с использованием:

- профессиональные ассоциации предпринимателей региона;
- учреждения в стране и регионах;
- государственное и местное самоуправление.



Рисунок 1. Кластер независимых предприятий

Под экономическим кластером мы понимаем систему предприятий, объединенных общим для всех материальным, финансовым и информационным потоком.

Бизнес-секторы кластера - это в основном экономические отношения между независимыми хозяйствующими субъектами, и их правильнее рассматривать как кластер. Кластер - это группа взаимодополняющих, географически близких предприятий с общей направленностью деятельности и услуг. Кластеры, как правило, представляют собой специализированную сеть различных организаций в пределах определенного района, чья производственная или сервисная деятельность неразрывно связана с коммерческой, торговой, исследовательской или потребительской деятельностью последних. Когда мы анализируем теоретические взгляды американских, британских и скандинавских научных школ на проблемы повышения конкурентоспособности предприятия, региона и страны, конкурентоспособность и конкурентные преимущества формируются и используются на региональном и местном уровнях, во-вторых, мы делаем вывод, что конкурентное преимущество и конкурентоспособность могут быть достигнуты на региональном и местном уровнях за счет организации производственных зон, индустриальных парков, взаимосвязанных кластеров. Эти кластеры возникают во всем мире как транснациональные корпорации. Экономические кластеры могут включать различные структуры, профсоюзы, науку и образование, стандартизацию и отдельные государственные учреждения.

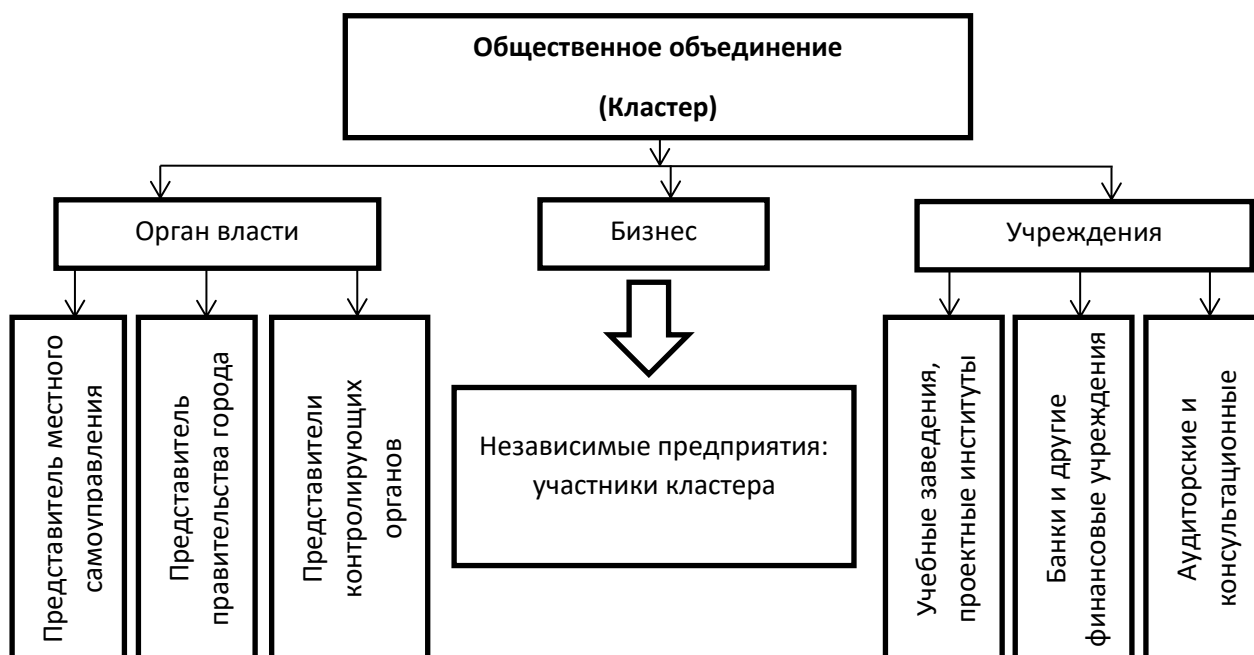

Рисунок 2. Экономические кластеры.

За счет создания кластеров, во-первых, появляется возможность развития конкурентной среды на региональных рынках, формирования новых конкурентных структур и повышения конкурентоспособности малого бизнеса. Во-вторых, формирование кластеров будет сосредоточено на микроэкономических факторах, основанных на местных предприятиях и рынках, эффективном использовании природных ресурсов,

высококвалифицированной рабочей силе и максимальном использовании существующей инфраструктуры. Основываясь на микроэкономическом подходе, кластеры адаптируются к местным условиям и налаживают производство на основе местного применения. В-третьих, кластеры взаимодействуют с органами государственной власти и местного самоуправления, предоставляя инновационную продукцию и услуги научно-исследовательским и образовательным учреждениям. В-четвертых, кластеры помогают стимулировать и увеличивать инновационный потенциал малого бизнеса и частного предпринимательства. Поэтому первичным объектом организации кластера является малый бизнес и частное предпринимательство. Кластер основан на взаимодействиях, жестких экономических механизмах, договоренностях. Организация кластеров осуществляется на местном уровне и действует на основе внеэкономического механизма - взаимного доверия и сотрудничества. Создание предпринимательских кластеров позволит занять новые сегменты в быстро меняющейся рыночной среде. Несмотря на то, что в зарубежных странах постоянно применяются деловые союзы для обеспечения конкурентных преимуществ на региональном рынке услуг, широко используются маркетинговые возможности, Процесс формирования кластеров в нашей стране идет медленно. Формирование (интеграция) бизнес-кластеров способствует формированию следующих множественных факторов.

Использованные источники:

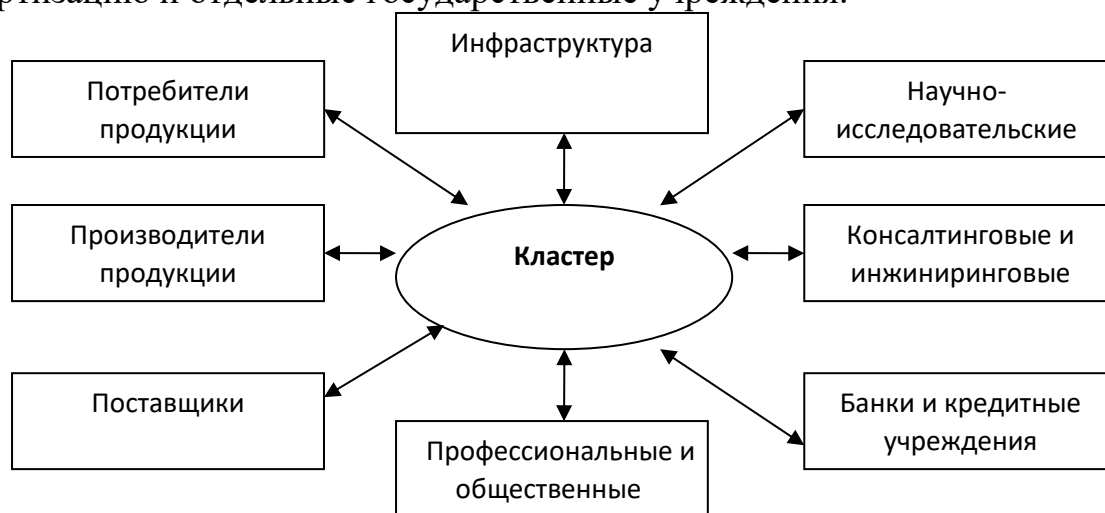
1. Кантильон Р. Основы предпринимательской деятельности.- М.: 1994. – 144 с.
2. Шумпетер Й. Теория экономического развития. –М.:1982.–230 с., 55.Хизрич Р. Питерс М. Предпринимательство. Вып 1. –М.: 1998.– 126 с.
3. Сей Ж.Б. Трактат политической экономии – М.: Экономика. 1980.-С.217.
4. 57.Зайнуддинов Ш.Н. Инновационный менеджмент. –Т.: Академия, 2006. –С.267;

*Ибрагимова Ш.
преподаватель
Ферганский государственный университет
Исмоилова З.
студент
Ферганский государственный университет*

ФОРМИРОВАНИЕ МЕТОДИЧЕСКОЙ КОМПЕТЕНТНОСТИ БУДУЩИХ УЧИТЕЛЕЙ НАЧАЛЬНОЙ ШКОЛЫ

Аннотация: Методологическая компетентность, являющаяся важным компонентом профессиональной компетентности, играет важную роль в работе учителей начальных классов. В статье рассматриваются методическая компетентность, ее составляющие, задачи методической компетентности и способы формирования этой компетентности у учителей начальных классов.

Ключевые слова: компетентность, методическая компетентность, акмеологическое, новаторское, когнитивное.

*Ibragimova Sh.
teacher
Ferghana State University
Ismoilova Z.
student
Ferghana State University*

FORMATION OF METHODOLOGICAL COMPETENCE OF FUTURE PRIMARY SCHOOL TEACHERS

Abstract: Methodological competence, which is an important component of professional competence, plays an important role in the work of primary school teachers. The article deals with methodological competence, its components, tasks of methodological competence and ways of forming this competence in primary school teachers.

Keywords: competence, methodological competence, acmeological, innovative, cognitive.

Одним из способов существенного влияния педагогических навыков учителя на развитие его квалификации, педагогических способностей, педагогической компетентности является совершенствование навыков непрерывного профессионального образования. Сегодня понятие педагогической компетентности широко изучается многими

исследователями. В этом случае понятие «компетентность» можно определить следующим образом. Понятие компетенции определяется как «нетрадиционные ситуации, когда специалист ведет себя в неожиданных ситуациях, общается, использует новый подход в отношениях с конкурентами, выполняет неоднозначные задачи, использует противоречивую информацию, постоянно развивается и комплексно. иметь план действий в процессе ».

Сегодня в научно-педагогической среде ведутся острые дискуссии о природе и структуре профессионально-педагогической компетентности. Европейские исследователи В.А. Адольф, Н.В. Кузьмина, А. Маркова, Э. Пупышева, Г. Саволайнен, Л. Шкерин и др. Различают разные типы профессиональных компетенций: методологические, инновационные, психологические, творческие, коммуникативные и другие. Среди перечисленного особое место занимает методическая компетентность учителя, поскольку включает в себя ряд других компетенций, кроме того, именно его уровень определяет уровень профессионализма специалиста в области образования.

Известно, что фундамент знаний, передаваемых учащимся, закладывается в начальной школе. Именно на этом этапе передаются знания, лежащие в основе развития сознания и мировоззрения человека. Соответственно, духовная, нравственная и профессиональная зрелость учителей начальной школы важна для развития учащихся, которых они обучают.

Ряд исследователей выразили разные взгляды на методическую компетентность учителя в своей исследовательской работе. В частности, по мнению О.В.Тумашевой, методическая компетентность педагога - это приобретение методических знаний, навыков и методов работы, признание их ценности как для профессиональной деятельности, так и для взаимодействия в обществе, опыт решения методических задач, - считается как неотъемлемая характеристика личности, которая подразумевает готовность и способность к обучению и самосовершенствованию [1].

Т. Гущина описывает методическую компетентность как целостный мультидисциплинарный признак личности и деятельности учителя, обобщающий производственный опыт, систематическое приобретение знаний, умений и навыков в области методологии и оптимальное сочетание профессионально-педагогической деятельности. [4].

И. Ковалёва рассматривает методическую компетентность как неотъемлемую черту деловых, личностных и нравственных качеств учителя, которая является методической, методической и систематическое изучение исследовательских знаний, умений, опыта, мотивации, способности и готовности к творческой самореализации в научной, методической и педагогической деятельности отражает уровень [4].

Важнейшим направлением развития отдельных компонентов методической компетентности учителя является развитие его методологического мышления и методической культуры.

На основе анализа профессиональной деятельности педагога Л.В. Исходя из предложенной Шкериной структуры профессионально-педагогической компетентности, методическая компетентность учителя делится на три компонента: познавательный, деятельностный и социально-личностный компонент [2].

Когнитивный компонент методологической компетентности учителя включает понимание владения учителем системой методологических знаний, а также важность и значимость этих знаний для него самого, как для профессиональной деятельности, так и для профессионального роста.

Компонент деятельности также включает в себя возможность реализовывать основные виды методической деятельности, анализировать и оценивать результаты своей деятельности, изменять их исходя из их соответствия ожидаемым, запланированным результатам.

В основе социально-личностной компетентности учителя лежат личные качества, необходимые в его методической деятельности и необходимые для достаточного и активного взаимодействия с обществом. В результате изучения исследования перед исследователями может быть поставлен ряд задач концепции методологической компетентности: акмеологической, инновационной, прогностической, интегральной, стимулирующей, управленческой, рефлексивной [1].

Акмеологическая задача направлена на достижение профессиональной и личностной зрелости учителя. Методическую компетентность учителя можно рассматривать как результат саморазвития субъекта образовательного процесса, обогащения личности учителя новыми профессиональными качествами, поднимающими его на более высокий уровень профессионализма. Основные «усилия» акмеологической функции методической компетентности учителя направлены на развитие профессионального потенциала специалиста в области образования, его творческих способностей, индивидуальности.

Инновационная задача - устранение существующих негативных стереотипов в профессиональной деятельности учителя, процесс формирования высокоуровневых методических умений учителя, формирование аналитических навыков, позволяющих школьникам глубже проникать в суть учебного процесса. в зависимости от. В контексте развития современного образования учителю важно понимать важность и необходимость инновационных процессов, происходящих в школе, знать инновационные технологии обучения и способы их внедрения в учебный процесс. Следует отметить, что в результате исследования мы видим, что в школьной системе существует дополнительная мотивация учащихся к

обучению за счет использования инновационных технологий, в частности, ИКТ [6].

Задача прогнозирования - развить умение учителя предвидеть будущие методологические проблемы профессиональной деятельности, разрабатывать модели их решения, предвидеть последствия принимаемых решений.

Интегральная функция обеспечивает связь между предметными, педагогическими, психологическими, методическими знаниями и методами деятельности. Мотивационная задача - развитие профессиональной мотивации учителя, стремления к восприятию своего предмета, педагогических, психологических, методических знаний, необходимых для осуществления эффективной методической деятельности, для обеспечения положительного отношения к профессиональной деятельности учителя в целом. .

Задачей менеджмента является, с одной стороны, управление собственной деятельностью учителя в образовательном процессе (планирование, организация, корректировка и т. Д.), С другой стороны, деятельность студентов по приобретению предметных знаний и деятельность, направленная на развитие каждого ученика. обеспечивает управление методами. Развитие методической компетентности сопровождается изменением его деятельности, мотивов, целей, использованием новых средств и методов, методов и программ деятельности. В результате различных педагогических изменений формируются методические способности учителя. Педагогический педагог - это педагог, умеющий преодолевать трудности воспитания, умеющий понимать особенности подрастающего поколения, умеющий чувствовать их чувства, чей внутренний мир тонок и слаб. , это человек с глубоким научным складом ума, способный видеть различные трудности в жизни ребенка и умело подходить к ним, сочетая знания и творчество. Таким образом, на основании изучения и анализа научных источников можно сделать следующие выводы:

Методологическая компетентность, обеспечивающая способность распознавать и решать методологические проблемы, возникающие в процессе педагогической деятельности учителей, является ключевым компонентом профессиональной компетентности.

Методическая компетентность учителя имеет свои компоненты и на их основе служит основой для развития имеющейся методической компетентности учителя на протяжении всей деятельности.

Перспективные учителя начальных классов достигают развития своих методических знаний, изучая задачи методической компетенции и применяя их на практике.

Использованные источники:

1. О.В. Тумашева О методической компетентности учителя / Вестник КГПУ им. В.П. Астафьева. Методика преподавания. 2009 (1).
2. Шкерина, Л.В. Мониторинг качества профессионально-педагогической подготовки будущего учителя в педагогическом вузе: учебно-метод. пособие / Л.В. Шкерина, В.А. Адольф, Г.С. Саво-лайнен, М.Б. Шашкина, М.В. Литвинцева; Краснояр. гос. ун-т им. В.П. Астафьева. – Красноярск, 2004. – 244 с.

*Игнатенко Е.В.
студент группы 12002033
Институт инженерных и цифровых технологий
НИУ «БелГУ»
Россия, г. Белгород*

*Игнатенко П.В.
студент группы 12002041
Институт инженерных и цифровых технологий
НИУ «БелГУ»
Россия, г. Белгород*

*Губкина Л.А.
студент аспирантуры 2-го года обучения
Институт инженерных и цифровых технологий
НИУ «БелГУ»
Россия, г. Белгород*

*Губкин А.В.
студент группы 12002041
Институт инженерных и цифровых технологий
НИУ «БелГУ»
Россия, г. Белгород*

ПРОЕКТИРОВАНИЕ ЭКСПЕРТНОЙ СИСТЕМЫ ПОДБОРА ОДЕЖДЫ С ПОМОЩЬЮ ОБОЛОЧКИ-ИНТЕРПРЕТАТОРА БАЗ ЗНАНИЙ ESWIN

Аннотация: в данной статье описан процесс создания экспертной системы при помощи продукта Clothes Advisor на базе оболочки экспертной системы ESWin. Экспертная система позволяет выбрать в качестве цели не только рекомендацию по подбору стиля одежды, исходя из требований пользователя, но и запросить справочную информацию.

Ключевые слова: экспертная система, подбор одежды, искусственный интеллект.

*Ignatenko E.V.
group student 12002033
Institute of Engineering and Digital Technologies
NRU "BelGU"
Russia, Belgorod*

*Ignatenko P.V.
group student 12002041
Institute of Engineering and Digital Technologies
NRU "BelGU"*

*Russia, Belgorod
Gubkina L.A.
2nd year postgraduate student
Institute of Engineering and Digital Technologies
NRU "BelGU"
Russia, Belgorod
Gubkin A.V.
group student 12002041
Institute of Engineering and Digital Technologies
NRU "BelGU"
Russia, Belgorod*

DESIGNING AN EXPERT CLOTHING SYSTEM USING ESWIN KNOWLEDGE BASE INTERPRETER

Abstract: This article describes the process of creating an expert system using the Clothes Advisor product based on the ESWin expert system shell. The expert system allows you to choose as a goal not only a recommendation for the selection of a style of clothing, based on the user's requirements, but also to request reference information.

Keywords: expert system, clothing selection, artificial intelligence.

Начиная с середины XX столетия и до сих пор, одним из самых значимых направлений развития науки и техники является искусственный интеллект. Отдельная область искусственного интеллекта - инженерия знаний – занимается разработкой экспертных систем, развитием средств представления и обработки знаний на компьютере. Экспертная система - система искусственного интеллекта, содержащая знания об определенной слабо структурированной и трудно формализуемой узкой предметной области и способная предлагать пользователю разумные решения и их объяснения. Экспертные системы играют роль эксперта и решают задачи диагностики, прогнозирования или планирования.

Инструментальное средство разработки экспертных систем – это язык программирования, используемый разработчиком для построения экспертной системы.

В наши дни широко используются экспертные системы, помогающие при выборе решения для конкретной задачи. Программное средство ESWin является одним из наиболее доступных представителей продукционно-фреймового класса экспертной системы.

Целью работы является разработка экспертной системы Clothes Advisor на базе оболочки экспертной системы ESWin.

Экспертные системы выдают советы, проводят анализ, выполняют классификацию, дают консультации и ставят диагноз. Они ориентированы

на решение задач, обычно требующих проведения экспертизы человеком-специалистом. В отличие от машинных программ, использующий процедурный анализ, экспертные системы решают задачи в узкой предметной области на основе дедуктивных рассуждений.

В экспертной системе первоначально рассматривалось большое количество признаков одежды, оказывающих влияние на ее выбор. Однако, полученная модель является достаточно большой как в структурном, так и понятийном плане. Фрагмент полученной концептуальной модели приведен на рисунке 1.



Рисунок 1 – Фрагмент разработанной концептуальной модели

Объектами исследования являются человек с его набором качеств, характеристик, вкусов и предпочтений, образа жизни, а также подходящая индивидуально одежда. Главными исследуемыми характеристиками стали: возраст, темперамент, пол, образ жизни, характер. В зависимости от того, сколько полных лет человеку, он относится к одной из четырех возрастных групп: подросток, молодой, взрослый, зрелый.

В ходе реализации экспертной системы столкнулись с трудностями, связанными с тем, что, количество правил для экспертной системы превысит 150 тысяч. Поэтому было принято решение ограничить предметную область решаемой задачи выбором стиля одежды с представлением образцов каждого стиля.

Подбор стиля одежды будет проводиться по двум основным критериям – это образ жизни и внешность. Каждая из этих частей будет в свою очередь состоять из двух подчастей. Получившаяся концептуальная схема представлена на рисунке 2.

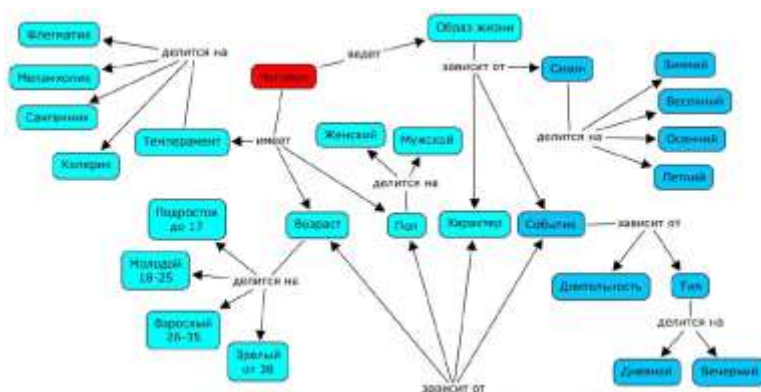

Рисунок 2 – Концептуальная схема

Как видно из концептуальной схемы, каждая задача состоит из двух подзадач, например, «внешность» состоит из «лицо» и «фигура» то есть на внешность женщины оказывают решающее влияние именно лицо и фигура.

Так как при разработке экспертной системы Clothes Advisor в качестве инструментального средства была использована экспертная оболочка продукционно-фреймового типа ESWin, то следует отметить, что из трех вышеуказанных компонентов системы логический анализатор не подвергался изменениям, интерфейс системы был изменен в части декорирования, а база знаний создавалась с «нуля».

Разработка базы знаний прототипа включает в себя ввод всех необходимых правил согласно структурной схеме базы знаний. Все правила перечислены в таблицах во втором разделе, их общее число составляет 177 штук. Полученный результат тестирования соответствует графу выполнения тестового примера, приведенному на рисунке 3.

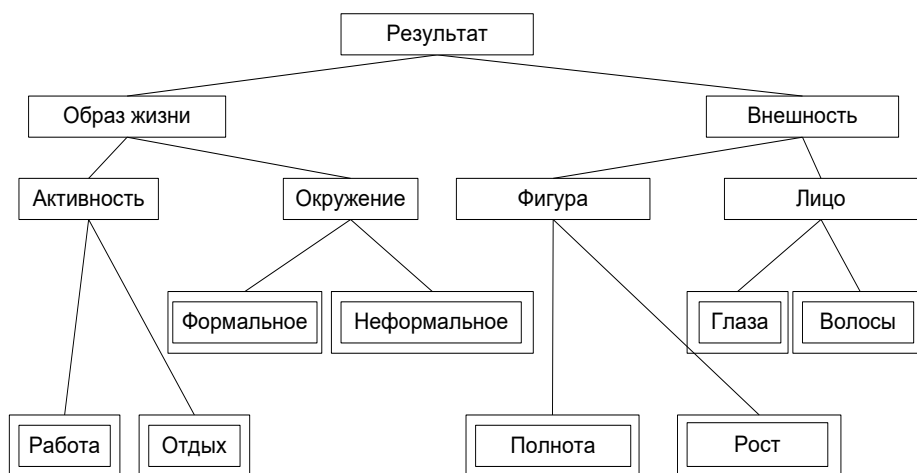

Рисунок 3 - Граф для тестового примера

При запуске экспертной системы была выбрана цель – подбор стиля одежды в зависимости от значимых параметров. После выбора цели появилось первое диалоговое окно, которое сопровождалось комментарием к вопросу.

В результате цель поиска была достигнута и в сообщении выведена полученная рекомендация – клиенту подойдут джинсы любых моделей, верх должен быть по фигуре. Экспертная система позволяет выбирать в качестве цели не только рекомендацию по подбору стиля одежды, исходя из требований пользователя, но и запросить справочную информацию. В результате проделанной работы, были выполнены все цели и задачи. Создан программный продукт - экспертная система Clothes Advisor на базе оболочки экспертной системы ESWin.

Использованные источники:

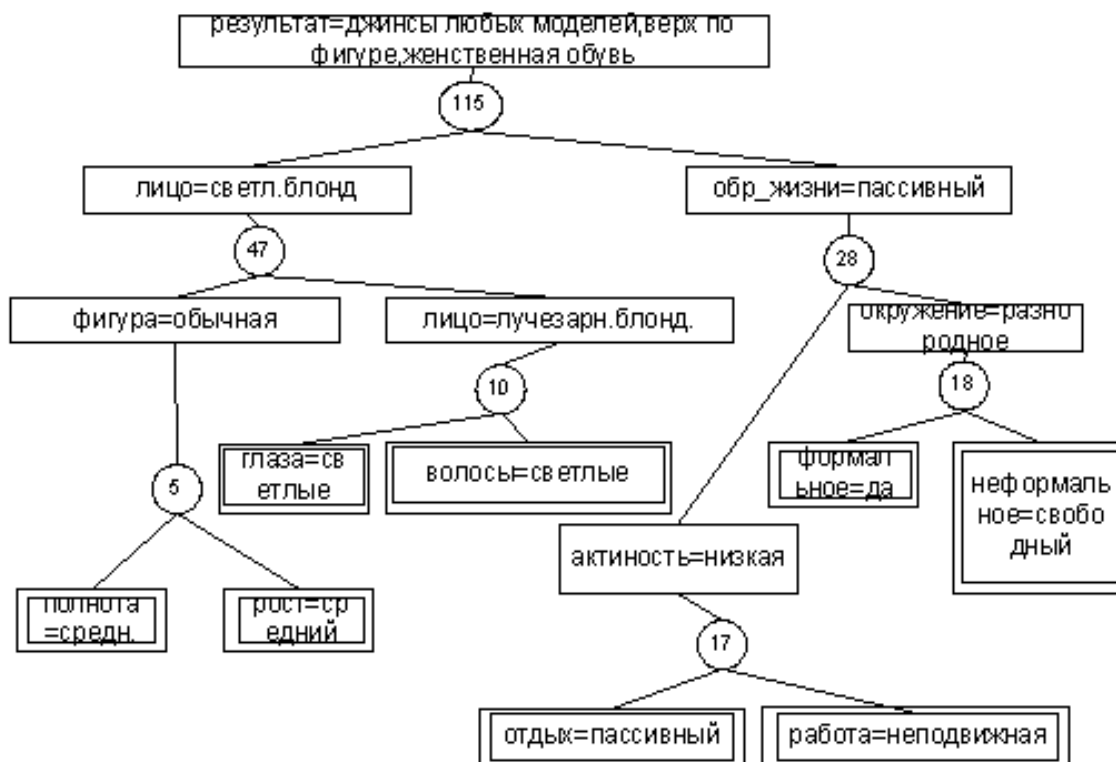
- 1.Джексон П. Введение в экспертные системы: Учебное пособие. Пер. с англ. – М.: «Вильямс», 2012. – 624 с.
- 2.Тельнов Ю.Ф. Интеллектуальные информационные системы. / Московский международный институт эконометрики, информатики, финансов и права. - М.,2014. - 82 с.

**АНАЛИЗ ФИНАНСОВО-ЭКОНОМИЧЕСКИХ ИТОГОВ И
ПРОБЛЕМ РЕАЛИЗАЦИИ ГОСУДАРСТВЕННЫХ ПРОГРАММ В
СФЕРЕ КУЛЬТУРЫ СУБЪЕКТОВ РФ**

Аннотация: Значимость всех мероприятий и услуг, финансируемых государством в рамках сферы культуры, очень высока, поскольку функции культуры состоят в духовном обогащении человека и воздействии через это на конечные экономические результаты. Важная проблема, которая затрагивается в данной статье – это отсутствие единой систематизированной классификации взаимосвязанных между собой отчетных показателей, характеризующих результаты финансируемых мероприятий госпрограмм ПФО в сфере культуры.

Ключевые слова: субъекты Приволжского федерального округа; бюджетирование, ориентированное на результат; государственная программа; целевые показатели; ожидаемые результаты

**ANALYSIS OF FINANCIAL AND ECONOMIC RESULTS AND
PROBLEMS OF IMPLEMENTING STATE PROGRAMS IN THE
SPHERE OF CULTURE OF SUBJECTS OF THE RUSSIAN
FEDERATION**

Abstract: The significance of all activities and services financed by the state within the framework of the sphere of culture is very high, since the functions of culture are to enrich a person spiritually and thereby influence the final economic results. An important problem that is touched upon in this article is the lack of a unified systematic classification of interconnected reporting indicators characterizing the results of the funded activities of the Volga Federal District state programs in the field of culture.

Keywords: subjects of the Volga Federal District; performance budgeting; Government program; target indicators; Expected results

Культурный комплекс представляет собой совокупность предприятий, учреждений и организаций, решающих специфические задачи

по развитию и самореализации личности, гуманизации общества и сохранению самобытности народов.

Государственные программы являются признанным в мировой практике механизмом концентрации ограниченных ресурсов для решения приоритетных проблем, которые стоят перед государством, особенно в тех случаях, когда возможности привлечения ресурсов негосударственного сектора экономики исчезающе малы.

Существующая российская практика разработки и реализации госпрограмм не идеальна.

- соответствующая правовая база не отличается стабильностью;
- количество программ, инициируемых государственными заказчиками, не соответствует реальным возможностям их финансирования;
- слабо прорабатываются альтернативные варианты достижения целей ГП и возможности привлечения внебюджетных источников финансирования;
- выбор целевых индикаторов часто является недостаточно обоснованным;
- зачастую отсутствует связь между целевыми показателями и результатами реализации госпрограммы;
- качество контроля за ходом реализации программ со стороны государственных заказчиков оставляет желать лучшего;
- применяемые методики оценки эффективности ГП зачастую уязвимы для критики и др.

Разработка научно обоснованных подходов к устранению каждого из этих недостатков, приведенный перечень которых не является исчерпывающим, заслуживает отдельного исследования [1, с. 55].

За основу исследования темы статьи выбраны государственные программы в сфере культуры Приволжского федерального округа (ПФО).

Анализ финансового обеспечения мероприятий госпрограмм сферы культуры ПФО показал, финансирование осуществляется из различных источников, основным из которых являются бюджетные средства субъектов ПФО.

Проанализировав состав и структуру паспортов и отчетов госпрограмм сфере культуры ПФО можно сделать следующие выводы:

- в госпрограммах имеется избыточное количество целевых показателей;
- отсутствует единый перечень целевых показателей для всех госпрограмм определенной сферы;
- отсутствует взаимосвязь между целевыми показателями и результатами реализации госпрограмм.

Проанализирован опыт реализации госпрограмм сферы культуры в некоторых регионах.

Сопоставление целевых показателей и ожидаемых результатов реализации госпрограмм сферы культуры ПФО

Наименование	Целевые показатели	Ожидаемые результаты	Совпадения
Башкортостан	7	7	7
Марий-Эл	14	12	12
Мордовия	6	6	6
Татарстан	29	29	29
Удмуртия	5	5	5
Чувашия	5	5	0
Кировская область	5	0	0
Нижегородская область	7	7	7
Оренбургская область	3	4	0
Пензенская область	6	6	6
Самарская область	2	8	0
Саратовская область	6	5	0
Ульяновская область	46	16	0
Пермский край	2	2	2

В составе государственной программы «Развитие культуры Оренбургской области» на 2014–2020 годы осуществлялась реализация мероприятий 2 подпрограмм.

По итогам 2017 года в полном объеме реализовано 17 мероприятий из 17 утвержденных. Достигнуты значения 24 показателей (индикаторов) из 24 запланированных, из которых 4 показателя (индикатора) государственной программы и 20 показателей (индикаторов) подпрограмм. Коэффициент эффективности реализации государственной программы по итогам 2017 года составил 0,94.

Целевые показатели госпрограммы «Развитие культуры Оренбургской области»

Наименование	2017	2018	2019	2020	2021
	факт	факт	факт	план	план
Доля объектов культурного наследия, информация о которых внесена в электронную базу данных единого государственного реестра объектов культурного наследия народов РФ, в общем количестве объектов культурного наследия области, %	90,0	90,0	-	-	-
Посещаемость государственных библиотек и музейных учреждений Оренбургской области, тыс. человек	723,7	770,9	-	-	-
Посещаемость театрально-концертных и культурно-досуговых мероприятий, проводимых государственными учреждениями Оренбургской области, тыс. человек	547,9	588,2	-	-	-
Увеличение числа посещений организаций культуры, тыс. человек	-	-	9730,6	9599,9	9737,6
Отношение средней заработной платы работников учреждений культуры к средней зарплате, %	90,7	101,0	101,8	100	100
Уменьшение доли выявленных объектов культурного наследия, от общего количества выявленных объектов культурного наследия, %	-	-	95,33	90	85

Расходы на реализацию государственной программы в 2017 году произведены в сумме 883,2 млн. рублей или 97,1 процента к плановым назначениям, установленным государственной программой. Результат комплексной оценки эффективности реализации государственной программы по итогам 2017 года составил – 0,86, эффективность реализации программы признается «средней».

По итогам 2018 года в полном объеме реализовано 16 мероприятий из 17 утвержденных. Достигнуты значения 23 показателей (индикаторов) из 24 запланированных, из которых 4 показателя (индикатора) государственной программы и 20 показателей (индикаторов) подпрограмм. Коэффициент эффективности реализации государственной программы по итогам 2018 года составил 0,964.

Расходы на реализацию государственной программы в 2018 году произведены в сумме 1 139,0 млн. рублей или 99,4 процента к плановым назначениям. Результат комплексной оценки эффективности реализации

государственной программы по итогам 2018 года составил – 0,907, эффективность реализации программы признается «средней».

По итогам 2019 года в полном объеме реализовано 17 мероприятий из 18 утвержденных. Достигнуты значения 36 показателей (индикаторов) из 38 запланированных, из которых 3 показателя (индикатора) государственной программы и 33 показателей (индикаторов) подпрограмм. Коэффициент эффективности реализации государственной программы по итогам 2019 года составил 0,983.

Расходы на реализацию государственной программы в 2019 году произведены в сумме 1 716,7 млн. рублей или 98,7 процента к плановым назначениям. Результат комплексной оценки эффективности реализации государственной программы по итогам 2019 года составил – 0,925, эффективность реализации программы признается «средней»

Целевые показатели госпрограммы «Культура Удмуртии»

Наименование	2017	2018	2019	2020	2021
	факт	факт	факт	план	план
Увеличение количества посещений организаций культуры в Удмуртской Республике по сравнению с предыдущим годом; процентов	4	4	5	6	6
Повышение уровня удовлетворенности граждан РФ качеством предоставления гос. (мун.) услуг в сфере культуры; %	98	96,3	96,3	90	90
Динамика значений соотношения среднемесячной заработной платы работников гос. (мун.) учреждений культуры в Удмуртской Республике и среднемесячного дохода от трудовой деятельности в Республике; %	90,6	101	100,7	70	90
Объем средств на культуру из внебюджетных источников; млн. руб.	-	415,6	452,9	358,5	376,1
Доля зданий учреждений культуры и искусства, находящихся в удовлетворительном состоянии, в общем количестве зданий учреждений культуры и искусства в Республике, %	-	70,6	70,9	71	71

В 2017 г. на реализацию мероприятий госпрограммы «Культура Удмуртии» из средств республиканского бюджета израсходовано 1,07 млрд рублей.

Из запланированных 49 мероприятий 6 мероприятий получили финансовую поддержку из федерального бюджета. На конец 2017 года 2 основных мероприятия не выполнено в связи с тем, что 2 не получили финансовой поддержки, 1 мероприятие проводится раз в 2 года и 1 мероприятие не достигло целевого показателя.

В 2018 году на реализацию мероприятий программы из средств республиканского бюджета израсходована сумма - 1,24 млрд рублей.

Было запланировано достижение 59 целевых показателей по всем подпрограммам госпрограммы, из них: по 3 индикаторам нет данных; 15 индикаторов не достигли 100 процентного порога; 21 индикатор перевыполнил плановое значение; 20 индикаторов исполнены на 100 процентов. Из показателей, не достигнувших 100 процентного порога, 2 показателя не выполнены (один показатель подпрограммы «Поддержка профессионального искусства и народного творчества», второй показатель подпрограммы «Создание условий для реализации государственной программы»), остальные показатели выполнены выше среднего или практически выполнены. Из перевыполненных показателей 10 индикаторов превысили плановое значение не значительно, 9 показателей значительно превысили плановое значение (основная концентрация перевыполненных показателей находится в подпрограмме «Государственная охрана, сохранение и популяризация объектов культурного наследия (памятников истории и культуры) народов РФ»).

В 2019 году на реализацию мероприятий программы из средств республиканского бюджета израсходована сумма - 1 309 517,9 тыс. руб..

Было запланировано достижение 52 целевых показателей по всем подпрограммам госпрограммы Удмуртской Республики «Культура Удмуртии», из них: 1 целевой показатель не выполнен; 4 целевых индикатора не достигли 100 процентного порога; 27 целевых показателей перевыполнили плановое значение; 20 индикаторов исполнены на 100 %.

Целевые показатели госпрограммы «Культура Саратовской области»

Наименование	2017	2018	2019	2020	2021
	факт	факт	факт	план	план
Доля детей, привлекаемых к участию в творческих мероприятиях	7	8	9	10	11
Количество обслуженного населения учреждениями сферы культуры, в т. ч. нестационарными формами и в электронном виде	10,5	10,4	10,8	10,6	10,6
Доля объектов культурного наследия, информация о которых внесена в электронную базу данных единого госрестра объектов культурного наследия народов РФ, в общем количестве объектов культурного наследия	100	100	-	-	-
Доля объектов культурного наследия, находящихся в удовлетворительном состоянии, в общем количестве объектов культурного наследия федерального, регионального и местного значения	10,01	11,03	11,95	12,92	13,02
Количество выпускников профессиональных образовательных организаций в сфере культуры, трудоустроившихся по специальности в учреждения сферы культуры и сферы образования области в первый год после окончания образовательной организации	125	130	87	132	134
Количество посещений организаций культуры по отношению к уровню 2010 г.	-	91	91	0	0

В 2017 году в ходе реализации госпрограммы «Культура Саратовской области» не выполнен целевой показатель «количество выпускников профессиональных образовательных организаций в сфере культуры, трудоустроившихся по специальности в учреждения сферы культуры и сферы образования области в первый год после окончания образовательной организации» (факт – 125 человек, план – 128 человек) в связи с тем, что 3 выпускника, планирующие трудоустройство после окончания обучения, были призваны в ряды Вооруженных сил РФ

Достигнутые в целом результаты реализации госпрограммы, полнота использования бюджетных средств, предусмотренных на ее реализацию, и полнота реализации мероприятий в соответствии с утвержденной методикой оценки эффективности позволяют в целом признать высокую степень эффективности госпрограммы (оценка – 0,93 балла).

В 2018 году в ходе реализации госпрограммы не выполнен целевой показатель «количество обслуженного населения учреждениями сферы культуры, в том числе нестационарными формами и в электронном виде» (факт – 10432,8 тыс. чел., план – 10575,2 тыс. чел.). Не достижение

показателя обусловлено сокращением учреждений сферы культуры на 10 единиц, что повлекло за собой оптимизацию клубных учреждений в селах.

Достигнутые в целом результаты реализации госпрограммы, полнота использования бюджетных средств, предусмотренных на ее реализацию, и полнота реализации мероприятий в соответствии с утвержденной методикой оценки эффективности позволяют в целом признать высокую степень эффективности госпрограммы (оценка – 0,92 балла).

В 2019 году в ходе реализации госпрограммы не выполнен целевой показатель «количество выпускников профессиональных образовательных организаций в сфере культуры, трудоустроившихся по специальности в учреждения сферы культуры и сферы образования области в первый год после окончания образовательной организации» (факт – 87 чел., план – 130 чел.) в связи с тем, что увеличилось количество выпускников профессиональных образовательных организаций в сфере культуры, продолживших обучение в ВУЗах.

Достигнутые в целом результаты реализации госпрограммы, полнота использования бюджетных средств, предусмотренных на ее реализацию, и полнота реализации мероприятий в соответствии с утвержденной методикой оценки эффективности позволяют в целом признать высокую степень эффективности госпрограммы (оценка – 0,96 балла).

Таким образом, использование несистематизированного перечня показателей результативности реализации государственных программ приводит к усложнению работы с отчетной информацией, отсутствию взаимосвязи между показателями финансирования и конечного результата, что затрудняет проведение оценки эффективности и результативности в сфере культуры.

Для решения выявленных проблем необходимо объединить целевые показатели культуры и образования, поскольку:

1 Культура и образование взаимообусловлены. Культура определяет цели, задачи и содержание образования. В то же время образование как часть культуры способствует ее сохранению и развитию. Связующим звеном между культурой и образованием выступает человек, который одновременно является и субъектом определенной культуры, и субъектом соответствующего образования.

2 Культура и образование связаны между собой: общим объектом – человек культуры и образования; общечеловеческими ценностями – культура, образование, человек и др.; творческим характером культурно-образовательной деятельности; общими функциями – развитие, обучение и воспитание человека.

3 Образование должно осуществляться в контексте определенного типа культуры. Культурологическая парадигма в большей степени ориентирована не на знания, а на усвоение элементов культуры.

4 Преподаватель должен быть носителем передовой культуры, он сам является ценностью и производит новые ценности – учеников.

5 Педагогическая деятельность – это, прежде всего, диалог между культурами, обмен культурными ценностями, а не просто передача знаний, умений и навыков.

6 Всякая история есть история культуры и образования. Поэтому, чтобы определять стратегические цели и задачи образования, нужно изучать историю развития культуры и образования.

Таким образом, именно культура представляет собой базовые ценности и социальные стереотипы, которые являются важным условием реализации современной системы образования. Знание этих основ, позволяет организовать действительно эффективный и продуктивный процесс образования.

Использованные источники:

1 Марголин А.М. Пути совершенствования методов оценки эффективности государственных программ / А.М. Марголин // Экономическая политика. – 2018. - № 6. – С. 54-81.

2 Информация о ходе реализации государственной программы «Развитие культуры Оренбургской области» на 2014 - 2020 годы за 2017-2019 годы [Электронный ресурс] : Официальный сайт Министерства культуры Оренбургской области. – Режим доступа: <http://minkult.orb.ru/deyatelnost/programmyi.html> (дата обращения: 01.12.2020)

3 Об утверждении государственной программы "Развитие культуры Оренбургской области" [Электронный ресурс] : Официальный сайт Министерства культуры Оренбургской области. – Режим доступа: <http://docs.cntd.ru/document/553135502> (дата обращения: 01.12.2020)

4 Об утверждении государственной программы Удмуртской Республики "Культура Удмуртии" [Электронный ресурс] : Официальный сайт Министерства культуры Удмуртской Республики. – Режим доступа: <http://docs.cntd.ru/document/430502823> (дата обращения: 01.12.2020)

5 Отчеты о реализации государственной программы Удмуртской Республики "Культура Удмуртии" за 2017-2019 годы [Электронный ресурс] : Официальный сайт Министерства культуры Удмуртской Республики. – Режим доступа: <https://minkultura.udmurt.ru/o-ministerstve/uchastie-v-tselevykh-programmakh/gosudarstvennaya-programma-kultura-udmurtii/> (дата обращения: 01.12.2020)

6 О государственной программе Саратовской области "Культура Саратовской области" [Электронный ресурс] : Официальный сайт Министерства культуры Саратовской области. – Режим доступа: <http://docs.cntd.ru/document/467701348> (дата обращения: 01.12.2020)

7 Отчеты о выполнении ГП СО "Культура Саратовской области до 2020 года" за 2017-2019 годы [Электронный ресурс] : Официальный сайт

Министерства культуры Саратовской области. – Режим доступа:
http://www.mincult.saratov.gov.ru/content/celevye_programmy.html (дата
обращения: 01.12.2020)

*Камилова Р.Ш., к.э.н.
доцент кафедры "Бухучет"
Кузнецова М.А.
студент 1 курса 2 группы
факультет "Экономический"
ФГБОУ ВО "Дагестанский государственный
университет"
РФ, г. Махачкала*

**ПРОГРАММНЫЙ КОМПЛЕКС «1С: ПРЕДПРИЯТИЕ».
СРАВНИТЕЛЬНЫЙ АНАЛИЗ, ДОСТОИНСТВА И НЕДОСТАТКИ**

Аннотация: В данной статье рассмотрены наиболее распространенные программы, с помощью которых осуществляется автоматизированный учет на предприятиях, организациях или иных хозяйствующих субъектах. Приведена сравнительная характеристика программных продуктов.

Ключевые слова: автоматизированный учет, автоматизированные программы, компьютеризация, эффективность управления.

*Kamilova R.Sh., c.e.s.
associate Professor of the Department "accounting"
Kuznetsova M.A.
student 1k. 2g.
faculty of « Economics»
FGBOU VO "Dagestan state University"
Russian Federation, Makhachkala*

**SOFTWARE PACKAGE "1С: ENTERPRISE".
COMPARATIVE ANALYSIS, ADVANTAGES AND DISADVANTAGES**

Abstract: In this article, the most common programs are considered, with the help of which automated accounting is carried out at enterprises, organizations or other economic entities. The comparative characteristics of software products are given.

Keywords: automated accounting, automated programs, computerization, management efficiency.

1С: Предприятие - это программная система, автоматизирующая все сферы хозяйственной деятельности. 1С: конкретные программные продукты, входящие в состав программной системы предприятия,

включают в себя функции и возможности, соответствующие назначению данного продукта.

1С: все компоненты программной системы предприятия можно разделить на технологические платформы и конфигурации. Технологическая платформа - это совокупность различных механизмов автоматизации хозяйственной деятельности, не зависящих от конкретных законодательных и бухгалтерских методов. Конфигурация-это решение для практического применения. Каждая конфигурация ориентирована на автоматизацию определенной сферы хозяйственной деятельности, естественно, в соответствии с принятым законодательством.

"1С: Предприятие" -это специализированная система управления базами данных (СУБД) с элементами объектно-ориентированного подхода, предназначенная для автоматизации деятельности предприятия.

"1С: Предприятие" - это программная система, включающая в себя созданную с ее помощью техническую платформу и прикладное решение (конфигурацию), которое может быть использовано только при наличии платформы.

Конечные пользователи всегда используют одно или несколько из тысяч прикладных решений на платформе 1С; Предприятие 8. Одной из самых известных является такая конфигурация от компании"1С". Такие как:"1С: Бухгалтерия","1С: Торговля и склад","1С: заработная плата и персонал".

Эти прикладные решения (конфигурации) создаются компаниями"1С", мультицифровыми компаниями и самим предприятием. Так как инструмент разработки "конфигуратор" предоставляется совместно с"1С; Предприятие 8". И тогда любой человек или компания может создать свою собственную конфигурацию (прикладное решение) для удовлетворения индивидуальных потребностей или продать.

Программная система "1С: Предприятие" предназначена для решения различных задач автоматизации бухгалтерского учета и управления, стоящих перед динамично развивающимися современными предприятиями.

1С: Предприятие - это система прикладных решений, построенных на единых принципах и на единой технологической платформе. Менеджеры могут выбирать решения, которые отвечают текущим потребностям предприятия и развиваются дальше по мере роста предприятия или расширения задач автоматизации.

Задачи бухгалтерского учета и управления могут существенно различаться в зависимости от вида деятельности предприятия, отрасли, конкретных обстоятельств поставляемой продукции или оказываемой услуги, размера и структуры предприятия, уровня требуемой автоматизации. Трудно представить себе единую программу для масштабного использования и удовлетворения потребностей большинства

предприятий. При этом менеджеру, с одной стороны, необходимо решение, соответствующее конкретной ситуации предприятия, с другой стороны, он понимает преимущества использования крупномасштабного тестового продукта. Совокупность этих требований обеспечивает система "1С: Предприятие" в виде программы.

1С: предприятия используют более 1 млн предприятий в России, странах СНГ и Балтии, Румынии и Вьетнаме.

Преимущества программы 1С

1. Основным преимуществом 1С является большое количество решений, инструментов, позволяющих выбрать удобную конфигурацию для выполнения задач.

2. Быстрая и качественная поддержка.

3. Учитывая все особенности вашего бизнеса и организации, вы можете создавать и совершенствовать индивидуальные проекты.

4. Отличная техническая документация-вы можете самостоятельно найти решение проблемы и ответ на поставленный вопрос.

5. Многосторонность.

6. Простота в использовании.

Недостатки 1С

1. Основные виды продукции: Бухгалтерский учет, предпринимательство, управление торговлей. Они ориентированы в основном на автоматизацию бухгалтерского и налогового учета и поддерживают гораздо лучше, чем другие конфигурации.

2. Программа требует регулярных настроек, улучшений и платных обновлений, которые чаще всего устанавливаются.

3. Конфигурацией должны заниматься исключительно профессионалы. Вам также может понадобиться кто-то, кто исправит ошибки в конфигурации, порекомендует сотрудникам использовать программу и установит обновления.

Программа 1С- это удобный и популярный инструмент для управления бизнесом. Вот почему компании (большие и малые) не могут функционировать без такого программного обеспечения.

Продукт - это простое и выгодное решение, которое поможет вам грамотно управлять своей компанией. Конечно, у 1С есть недостатки, но они незначительны по сравнению с достоинствами этого продукта.

Хотя система "1: С Предприятие " является далеко не единственным программным продуктом на рынке с аналогичной целью, она, безусловно, относится к самой популярной системе. Тот факт, что в этой программе можно работать, значительно повышает значимость любого эксперта. Изучение принципов работы системы, развитие ее функциональных возможностей во многом способствует развитию грамотных учетных процессов на предприятии.

Способность системы допускать одновременное использование нескольких различных валют, а также нескольких различных планов счетов во многом помогает решать текущие проблемы управленческого учета. Например, параллельно с Планом счетов, действующим в Российской Федерации, можно использовать международный план счетов ГААВ.

В программе всегда реализованы все необходимые функции работы бухгалтеров. В связи с тем, что все программы 1С стараются держаться на высоком уровне и прикладывают все возможные усилия для совершенствования своей системы, она будет выбрана компаниями не только сейчас, но и в будущем.

Использованные источники:

1. Федеральный Закон "О бухгалтерском учете" №402-ФЗ от 06.12.2011 г
2. Бойко, Э. В. 1С: Предприятие 8.0. Универсальный самоучитель / Э.В. Бойко. - М.: Омега-Л, 2020. - 232 с..
3. Тимофеев, Г. Конфигурирование и администрирование 1С: Предприятия / Г. Тимофеев. - М.: Феникс, 2020. - 0 с.
4. Шустикова, Т. 1С: Зарплата и Управление персоналом / Т. Шустикова. - М.: НТ Пресс, 2020. - 256 с.

УДК 657.6.

*Камилова Р.Ш., к.э.н.
доцент кафедры «Бухгалтерский учёт, анализ и аудит»
Магомедов А.Г.
студент 1 курса 2 группы магистратуры
экономический факультет
Федеральное государственное бюджетное образовательное
учреждение высшего образования «Дагестанский государственный
университет»
РД, г.Махачкала*

СОВЕРШЕНСТВОВАНИЕ СИСТЕМЫ НАЛОГОВОГО УЧЁТА

Аннотация: В данной статье рассматриваются вопросы касательно дальнейшего развития системы налогового учёта на экономических субъектах, устранении недочетов и противопоказаний в отдельных ее моментах. Сближение данного вида учёта и финансового бухгалтерского учёта. Раскрыты основные моменты требующие дальнейшего исправления и сближения между финансовым и налоговым бухгалтерскими учётами. Обобщены ключевые позиции на которые стоит обратить внимание.

Ключевые слова: налоговый учет, регистры, налог, амортизация, инвестиционный вычет, среднегодовая стоимость имущества.

*Kamilova R.Sh., candidate of Economics
associate Professor of the Department "Accounting, analysis and audit"
Magomedov A.G.
1st year student of the 2nd group of the master's degree
Faculty of Economics
Federal state budgetary educational institution of higher
education "Dagestan state University"
RD, Makhachkala*

IMPROVING THE TAX ACCOUNTING SYSTEM

Abstract: This article discusses issues related to the further development of the tax accounting system in economic entities, the elimination of shortcomings and contraindications in some of its aspects. Convergence of this type of accounting and financial accounting. The main points requiring further correction and convergence between financial and tax accounting are disclosed. The key positions that are worth paying attention to are summarized.

Keywords: tax accounting, registers, tax, depreciation, investment deduction, average annual value of property.

Налоговым учетом называется комплекс операций по формированию показателей заполнения налоговых деклараций по определенным налогам и сборам, которые платит предприятие при осуществлении своей текущей деятельности. Понятие сбора налогов по НК РФ имеет отношение только к налогу на прибыль организаций, но на практике под этой категорией понимается вся система аналитических данных, используемых при исчислении налогов и сборов для уплаты в бюджет. Общие сведения о начисленных и уплаченных предприятием налогах и сборах независимо от особенностей их расчета отражаются в бухгалтерских реестрах по счетам 68 «Расчеты с бюджетом по налогам и сборам» и 69 «Расчеты по социальному обеспечению и обеспечению безопасности». Налоговые декларации устанавливаются с расшифровкой размера налоговой базы по каждому виду налогооблагаемых объектов, применяемых налоговых льгот и размера суммы налогов, подлежащих уплате или возврату из бюджета. Любые изменения, снижающие размер налоговых вычетов, приветствуются руководством компании. Но эти расчеты должны иметь соответствующее отражение в документообороте организации, методах ведения бухгалтерского учета предприятий и других местных актах, чтобы подтвердить одну из основных причин - промышленную направленность сделок, учитываемую при проведении налогового контроля за правильностью погашения налогового долга.

Совершенствование налогового учета в конечном итоге сводится к уменьшению налоговой нагрузки и организации системы таким образом, чтобы компенсировать все ошибки при расчете налоговых обязательств. Снижение налоговой нагрузки возможно за счет тех налогов и сборов, показатели которых напрямую зависят от деятельности налогоплательщика и выбранного им налогообложения: корпоративный налог, НДС, акцизы, налог на выходное пособие, налог на имущество организаций, использующих упрощенную систему налогообложения (УСН), единый сельскохозяйственный налог (ЕСХН). Обязательством налогоплательщиков является учет объектов налогообложения. Налог на прибыль компании - это сумма прибыли, определяемая как разница между доходами и расходами. Обе категории должны быть отражены в налоговом учете. Деление доходов на налогоплательщиков и не облагаемых налогом может осуществляться двумя способами - на основании данных бухгалтерского учета или путем создания повторной истории налогового учета. При 1 способе обращается внимание на используемый метод признания доходов и результатов от нереализованных сделок в целях налогообложения: кассовый метод или метод начисления. Поскольку кассовый метод могут использовать только организации со средним доходом за 4 последовательных квартала в размере не более 1000000 рублей., то большинство из этих единиц принадлежат к сегменту малого бизнеса и применяют специальный налоговый режим.

Метод начисления позволяет учитывать доходы после доставки материальных цен, работ и услуг, то есть в момент формирования дебиторской задолженности покупателей и заказчиков. В бухгалтерском учете эта операция отражена проводками:

Дт62,76,70 Кт. - 90/ 1-отражают выручку от продажи продукции, работ, услуг основного производства ;

Дт 62, 76-91/1-Кт 91/1 - признанные операции для других транзакций, связанных с повторной ализацией активов и услуг, не принадлежащих к основной деятельности;

Дт 01,10,41,43,50,60.- Кт 91/1-выручка от других операций, которые привели к увеличению экономических выгод организации, приняты к учету.

Не облагаемых налогом доходы регистрируются в бухгалтерском учете, как правило, со счетом 91 «Прочие расходы и расходы», на чьем балансе они со счетов 86 «целевое финансирование и сохранение», 75 «с фондами расходы» и т. п., имеет существенное значение для определенных зон выхода или в результате реорганизации предприятия. Налоговый учет расходов имеет специфику, связанную с наличием рядовых расходов и расходов, не признанных при налогообложении прибыли - не доказанных или связанных с направлением производства, а также ограниченных нормами, определяемыми НК РФ, или отличающихся методом признания от правил бухгалтерского учета. Организацию налогового учета в этом случае, целесообразно свести к следующему: по совпадаемым в бухгалтерском и налоговом учете видам расходов можно применять регистры автоматизированной формы, составляемые в настоящее время с помощью ресурсов программного обеспечения, широко применяемых сегодняшними бухгалтерами, а при появлении расхождений - составляется бухгалтерская справка или регистр, в котором по каждому наименованию таких отклоняемых расходов приводится их название, величина для целей бухгалтерского и налогового учета, размер отклонения, его категория для формирования отчетности и объем отложенных налоговых активов или обязательств, включаемых в составляемую компанией бухгалтерскую отчетность.

Источниками данных о расходах являются реестры бухгалтерского учета и анализа счетов - 20 "Основное производство", 26» общехозяйственные расходы«, 90/2» себестоимость продаж«, 91/2» прочие доходы " и другие счета затрат и доходов в зависимости от категории расходов. Наибольшее количество отклонений, возможно при списании амортизации на приобретение или создание основных средств и нематериальных активов. Это может включать в себя:

1) критерий затрат: в бухгалтерском учете-40 тыс. руб., в налоговой-100 тысяч рублей.;

2) Дата начала амортизации по объектам, требующим государственной регистрации-в бухгалтерском учете-после регистрации, в налоговом-независимо от процессов с начала фактической операции;

3) единовременная амортизация части гонок-поездов-в бухгалтерском учете не предусмотрена, в налоговой-возможно, в размере 10%, на третьей-седьмой амортизационных группах-30% от первоначальной стоимости объектов на момент ввода в эксплуатацию;

4) методы амортизации: в бухгалтерском учете-четыре (линейный, порядок уменьшенного остатка, по сумме лет срока полезного использования, пропорционального объему произведенной продукции или выполненных работ), в налоговом-два (линейный и нелинейный);

5) Выбор метода амортизации: в бухгалтерском учете организация делает по своему выбору, в налоговом - в отношении недвижимости со сроком погашения более 20 лет используется только линейный метод;

6) признание результатов переоценки: в бухгалтерском учете-учтено, в налоговом учете переоценка не допускается;

7) изменить метод амортизации: в бухгалтерском учете невозможно, в налоговом - возможно. Переход от линейного к нелинейному - от нового календарного года, наоборот-только через пять лет;

8) не предусмотрено применение инвестиционного пары: в бухгалтерском учете, в налоговом учете для основных средств третьей по седьмую Амортизационные группы, т. е. со сроком эксплуатации от 5 лет 1 месяца до 20 лет.

В целом система сбора налогов строится самостоятельно в зависимости от особенностей расчетов с бюджетом каждого предприятия, но строить ее следует так, чтобы правильно и своевременно погасить налоговый долг, желательно, самыми законными способами снизить налоговую нагрузку на предприятие.

Использованные источники:

1. НК РФ часть 2 от 05.08.2000 №117-ФЗ (ред. 23.11.2020);
2. Кузнецова О.Н. Налоговая нагрузка на предприятие и способы ее оптимизации // Вестник Брянского государственного университета. 2016;
3. Ермакова Л.В., Дворецкая Ю.А., Ковалева Н.Н. Модель оптимизации финансово-учет- ной системы предприятия // Экономика. Социология. Право. 2017. № 2 (6). С. 32-37;
4. Гудкова О.В., Ермакова Л.В. Система налогового администрирования в РФ и пути ее модернизации 2015;
5. Черноусова К.С. Махмудов Т.Г. Проблемы современной налоговой системы российской федерации и способы ее совершенствования // . – 2019 – С. 111-119.

*Камилова Р.Ш., к.э.н.
доцент кафедры "Бухучет"
Кузнецова М.А.
студент 1 курса 2 группы
факультет "Экономический"
ФГБОУ ВО "Дагестанский государственный
университет"
РФ, г. Махачкала*

**ПРОГРАММНЫЙ КОМПЛЕКС «ПАРУС» И «ИНФИН-
БУХГАЛТЕРИЯ». СРАВНИТЕЛЬНЫЙ АНАЛИЗ, ДОСТОИНСТВА И
НЕДОСТАТКИ**

Аннотация: В данной статье рассмотрены наиболее распространенные программы, с помощью которых осуществляется автоматизированный учет на предприятиях, организациях или иных хозяйствующих субъектах. Приведена сравнительная характеристика программных продуктов.

Ключевые слова: автоматизированный учет, автоматизированные программы, компьютеризация, эффективность управления.

*Kamilova R.Sh., c.e.s.
associate Professor of the Department "accounting"
Kuznetsova M.A.
student 1k. 2g.
faculty of « Economics»
FGBOU VO "Dagestan state University"
Russian Federation, Makhachkala*

**SOFTWARE PACKAGE "SAIL" AND "INFIN-ASSOUNTS
DEPARTMENT". COMPARATIVE ANALYSIS, ADVANTAGES AND
DISADVANTAGES**

Abstract: In this article, the most common programs are considered, with the help of which automated accounting is carried out at enterprises, organizations or other economic entities. The comparative characteristics of software products are given.

Keywords: automated accounting, automated programs, computerization, management efficiency.

Современный Бухгалтерский учет применяется с помощью современных компьютерных технологий и бухгалтерских программных продуктов.

Бухгалтерская программа - это достаточно сложный инструмент, предназначенный для автоматизации профессиональных функций в очень сложной области человеческой деятельности.

Эти факторы определяют относительную сложность программных приложений, успешность электронного формата и каждый день в отражении экономического поведения. При автоматизации бухгалтерского учета совместного предприятия необходимо выбрать необходимую систему, исходя из работы и имеющихся ресурсов. При автоматизации учета важно не только перенести все документы в компьютер. Необходимо повысить эффективность учета и контроля за финансово-хозяйственной деятельностью предприятия, что в свою очередь повысит эффективность управления бизнесом и, следовательно, его эффективность. Лучшая бухгалтерская система, независимо от ее размеров, аппаратных и программных платформ и цен, должна обеспечивать качественный учет, надежный и простой в эксплуатации. Для того чтобы бухгалтерская программа могла автоматизировать учет совместного предприятия, она должна отвечать определенным требованиям.

Российский рынок компьютерного программного обеспечения предлагает широкий спектр вариантов бухгалтерского программного обеспечения: от простейшего, которое может производить минимум операций, необходимых небольшим компаниям, до очень широкого спектра продвинутых операций по проведению глубокого анализа. Мы анализируем преимущества и недостатки бухгалтерских процедур типа "Парус" и "Инфин-бухгалтерия", применяемых на российском рынке программных продуктов.

Система разработана компанией "Парус" и предназначена для малых и средних предприятий различных отраслей промышленности (торговля, сфера услуг, первичное производство, реклама и СМИ, общественное питание, туризм, иностранные компании и др.). Это простая, удобная, но в то же время мощная полнофункциональная система, позволяющая автоматизировать бухгалтерский учет;

- основные торговые процессы и складской учет;
- расчет заработной платы;
- кадровый учет.

Пользователями системы могут быть главные бухгалтеры и бухгалтеры, менеджеры по продажам и складские работники, специалисты в финансово-экономической сфере.

Система построена по принципу модульности, представляет собой совокупность модулей, каждый из которых предназначен для автоматизации одного из основных видов деятельности предприятия,

может работать как в автономном режиме, так и совместно с другими модулями комплекса,

"Парус" работает над созданием специализированных отраслевых решений для упрощения настройки и ввода в эксплуатацию систем. В то же время не исключено, что использование гибких инструментов настройки на каждом предприятии позволит персонализировать систему •

- бухгалтерия;
- реализация и склад;
- комплекс;
- учет договоров;
- комплектование;
- заработная плата;
- кадры.

Каждый модуль может быть реализован как отдельное приложение, но все преимущество модулей заключается в том, что при их использовании они представляют собой единый программный комплекс с общей базой данных.

Преимущества системы

- простота освоения;
- широкие функциональные возможности;
- высокая надежность функционирования;
- типовые настройки на различные типы предприятий;
- сокращение затрат на автоматизацию путем выбора оптимальной комплектации с возможностью ее дальнейшего наращивания;
- возможность анализа учетных данных и информации в базе данных.

Принцип работы системы "Парус" прост и мало чем отличается от принципов, содержащихся в других продуктах этой категории. Ввод информации в систему начинается с работы над основным документом. Платежная квитанция, квитанция и платежная квитанция, а также другие платежные файлы хранятся в специальном разделе, который обеспечивает прямой доступ. Счета-фактуры на выпуск продукции и счета-фактуры хранятся отдельно друг от друга. После ввода основного документа можно рассчитать бухгалтерскую часть документа. Использование различных справочников организационной и материальной ценности облегчает заполнение документов.

Компания «ИНФИН» является разработчиком популярных современных программ ИНФИН-Бухгалтерия, ИНФИН-Зарплата выпускаемых под маркой «ИНФИН-Управление».

Программные продукты INFIN характеризуются оригинальным и удобным дизайном, простотой обучения и эксплуатации в сочетании с широким спектром функциональных возможностей, позволяющих эффективно использовать программу. Готовые решения для малых и

средних предприятий и предпринимателей в сфере производства, услуг, торговли и строительства, ведение учета по обычной и упрощенной системе налогообложения, позволяют начать работу сразу после установки программы. Мощный механизм настройки позволяет специалистам за короткий промежуток времени адаптироваться к крупным предприятиям и предприятиям с конкретными учетными функциями.

Основные особенности серии «ИНФИН – УПРАВЛЕНИЕ»:

Бюджетная бухгалтерия:

Налоговый учёт:

Зарплата:

Персонал:

Экономический анализ:

Книга покупок и продаж

Преимущества комплекса «ИНФИН – УПРАВЛЕНИЕ»:

1. работа с большим количеством пользователей и объемом данных;
2. единая база данных для всех программ комплекса;
3. высокая скорость и надежность работы программы;
4. работа как «от проводки», так и от «документа»;
5. возможность создания специализированных рабочих мест;
6. возможность настройки любых экранов, просмотров и отчетов;

В условиях переходной экономики России автоматизация корпоративного учета и подготовки финансовой отчетности для налоговых органов является одной из важнейших задач, кроме того, должны существовать плановые и нерегулярные налоговые проверки, для которых могут потребоваться все бухгалтерские документы, в том числе и основные. Все это привело к широкому использованию САБУ в современной России.

Использованные источники:

1. Федеральный Закон "О бухгалтерском учете" №402-ФЗ от 06.12.2011 г
2. www.infin.ru
3. www.parus.ru - Корпорация Парус. Информационные системы
4. Шустикова, Т. 1С: Зарплата и Управление персоналом / Т. Шустикова. - М.: ИТ Пресс, 2020. - 256 с.

УДК 336.225.621.1.

*Камилова Р.Ш., к.э.н.
доцент кафедры "Бухучет, анализ и аудит"*

*Магомедов А.Г.
студент 1 курса 2 группы магистратуры
экономический факультет
Федеральное государственное бюджетное образовательное
учреждение высшего образования «Дагестанский
государственный университет»
РФ, г. Махачкала*

ОРГАНИЗАЦИЯ НАЛОГОВОГО УЧЁТА НА ПРЕДПРИЯТИИ

Аннотация: В статье подробно рассматриваются вопросы связанные с построением системы ведения налогового учёта на предприятии. В ней содержатся сведения касательно особенности учёта имущества организации с точки зрения налогового учёта. Приведён порядок подготовки к процессу организации налогового администрирования хозяйственных операций. Заключены основные моменты касающиеся всей налоговой работы на предприятии.

Ключевые слова: система налогового учета, аналитические регистры, учетная политика в целях налогообложения, налоговые регистры, прямые и косвенные расходы.

*Kamilova R.Sh., candidate of Economics
associate Professor of the Department "accounting, analysis and audit"*

*Magomedov A.G.
1st year student of the 2nd group
master's degree in Economics
Federal state budgetary educational institution of
higher education "Dagestan State University" of the Russian
Federation, Makhachkala*

ORGANIZATION OF TAX ACCOUNTING AT THE ENTERPRISE

Abstract: The article discusses in detail the issues related to the construction of a system of tax accounting in the enterprise. It contains information about the specifics of accounting for the organization's property from the point of view of tax accounting. The procedure for preparing for the process of organizing tax administration of business operations is given. The main points concerning all tax work at the enterprise are concluded.

Keywords: tax accounting system, analytical registers, accounting policy for tax purposes, tax registers, direct and indirect expenses.

Корпоративный налоговый учет - это правила и процедуры, которые формализуют информацию, необходимую для расчета налога на прибыль. Все организации, которые платят подоходный налог, ведут налоговый учет. Эта обязанность предусмотрена статьей 313 Налогового кодекса Российской Федерации. Что является основанием для формирования данных бухгалтерского учета, в какой форме и по каким правилам устанавливается организация налогового и расходного учета будет показано в данной статье.

Среди бухгалтеров часто утверждается, что обязанность вести налоговый учет (в том числе формирование налоговых регистров) возникает только тогда, когда бухгалтерских данных недостаточно. Однако представители финансового ведомства не согласны с такой точкой зрения, учитывая, что организация должна вести учет налогового расчета налога, но плательщик может по своему усмотрению разработать форму аналитических регистров. Кроме того, отсутствие налогового учета, являющееся серьезным нарушением правил учета доходов и расходов и объектов налогообложения, предусмотрено НК РФ санкциями в размере от 10 000 до 30 000 руб. (Если такое нарушение продолжалось в течение определенного периода времени).

Если отсутствие налогового учета приводит к занижению налоговой базы, то вам придется заплатить штраф в размере 20% от суммы неуплаченного налога, но не менее 40 000 рублей.

Налоговый кодекс Российской Федерации не устанавливает конкретных методов налогового учета. Он устанавливает только основные принципы налогового учета, определяет его цели и устанавливает перечень документов, подтверждающих данные бухгалтерского учета. Налогоплательщики должны самостоятельно организовать систему налогового учета.

В соответствии с этим перед специалистами в сфере финансовых услуг неизбежно встает задача фактического выполнения требований Налогового кодекса Российской Федерации. Для этого необходимо создать оптимальную систему учета, которая позволит минимизировать трудозатраты на обработку информации и обеспечить последующий контроль за формированием налоговой базы.

Данные, содержащиеся в налоговом учете, должны отражать:

- ❖ процедуры формирования сумм поступлений и расходов;
- ❖ порядок определения доли расходов, используемых для целей налогообложения в текущем (налоговом) периоде;
- ❖ сумма остатков расходов (убытков), связанных с расходами следующих налоговых периодов;
- ❖ порядок формирования суммы создаваемых резервов;
- ❖ суммы задолженности погашаются в налоговом бюджете (определяется на счетах бухгалтерского учета)

Налоговый кодекс Российской Федерации выделяет три уровня обобщения информации в налоговом учёте организации:

- первичные учетные документы (включая
- справку бухгалтера);
- аналитические регистры налогового учета;
- расчет налоговой базы.

Первичный налоговый документ основан на первичном бухгалтерском документе, в котором можно ввести дополнительные сведения для целей налогообложения. Регистры анализа налогового учета могут представлять собой накопительные ведомости, справки-расшифровки, специальные расчеты и другие документы аналогичного назначения, в которых группируются данные основных учетных документов.

Поскольку формат, отражающий данные налогового учета, не предусматривает соответствия между записями счетов, необходимо четко идентифицировать хозяйственные операции с бухгалтерскими записями и на этой основе разработать соответствующий налоговый реестр. С этой целью предлагается предусмотреть соответствующую графу для обозначения корреспонденции между счетами в реестре, выданном для целей налогообложения.

Правильность отражения хозяйственной операции в регистре налогового учета обеспечивается лицом, которое ее сформулировало и подписало. Исправления ошибок в регистре налогового учета должны быть заверены и подтверждены подписью исправителя с указанием даты и причины исправления.

Поскольку единая форма налогового учета на федеральном уровне или для отдельных видов экономической деятельности не установлена и не будет установлена, исключительное право на разработку этой формы принадлежит налогоплательщику.

Использованные источники:

1. Налоговый кодекс Российской Федерации (часть первая): Федеральный закон от 31.07.1998 № 146-ФЗ.;
2. Налоговый кодекс Российской Федерации (часть вторая): Федеральный закон от 05.08.2000 № 117-ФЗ.;
3. О бухгалтерском учете: Федеральный закон от 21.11.1996 № 129-ФЗ.
4. Об утверждении положений по бухгалтерскому учету: приказ Минфина России от 06.10.2008 № 106н.;
5. Филина Ф. Регистры налогового учета / Ф. Филина // Российский бухгалтер. – 2018.;
6. Пирогова Г.В. Организация налогового учета на предприятии / Г.В. Пирогова // Налоговый вестник. – 2017.

*Каримов Н.
старший преподаватель кафедры литературы и методики её
преподавания
ДжГПИ
Узбекистан
Каримова З.
преподаватель кафедры русского языка и методики
её преподавания
ДжГПИ
Узбекистан*

ФИЛОСОФИЯ РАННЕГО СРЕДНЕВЕКОВЬЯ

Аннотация: В качестве исследовательской задачи авторами была определена попытка изученности понятия «Философия раннего средневековья», актуальности нравственных взглядов великих мыслителей Востока.

Ключевые слова: Раннее средневековье, философия эпохи, шелковый путь, исламская философия, ханафизм, ашаризм, жабаризм, каризм, сифатиизм, мурджиизм, мутазилиизм.

*Karimov N.
senior Lecturer Department of Literature and Methods of its Teaching
JSPI
Uzbekistan
Karimova Z.
Lecturer Department of Russian Language and Teaching Methods
JSPI
Uzbekistan*

PHILOSOPHY OF THE EARLY MIDDLE AGES

Annotation: As a research task, the authors identified an attempt to study the concept of "Philosophy of the early Middle Ages", the relevance of the moral views of the great thinkers of the East.

Key words: Early Middle Ages, philosophy of the era, the Silk Road, Islamic philosophy, Hanafism, Asharism, Jabarism, Karism, Sifatiism, Murzhism, Mutaziliism.

Общеизвестно, что философия – это древняя ветвь человеческой духовной жизни и знаний. В течение почти трех тысяч лет люди во всех странах и регионах задавали вопросы в различных формах, сначала в

легендах, а затем в форме определенной системы теоретических структур и всех понятий: «что на самом деле окружает человека и какую роль играет и играет человек?» она пытается ответить на вопрос. Сейчас, в начале XXI века, существует множество теоретических концепций, которые пытаются ответить на вопросы, существующие в мире. Следует отметить, что философские взгляды прошлого и настоящего очень отличаются друг от друга. Однако есть общность, которая позволяет нам приравнивать эти вопросы именно к философским вопросам. На каждом этапе философской истории, в каждой философской системе человек пытается найти частицы истины в ответах на эти вопросы. Эти частицы входят в философскую структуру науки и составляют основу философии на каждом конкретном этапе.

В истории человечества будут такие периоды, когда огромный интеллектуальный потенциал любой нации, сформированной в конкретном регионе, внесет большой вклад в сокровищницу мировой цивилизации и культуры и окажет большое влияние на ее развитие. Многие ученые и мыслители, чьи имена остались в истории, живут и работают бок о бок, ведя общество к духовному росту и культурному развитию.

Известные ученые древней Греции Эпикур, Гераклит, Демокрит, Солон, Сократ, Платон, Аристотель и др. 7-5 вв. до н.э. или два-три века когда жили почти все мыслители древнего Китая Конфуций, Лао Цзи, Фун Цзи создавшие почти все античные религии и учения в Китае, были периодами великого возрождения, которые внесли огромный вклад в культурное достояние человечества.

Каждый человек объективно смотрящий на историю нашей страны, может увидеть этот уникальный процесс не один раз, а дважды. Без сомнений можно сказать, что IX-XI-века так называемое “Раннее средневековье” и период правления Амира Темура и темуридов были периодами такого великого возрождения истории человечества. Это помогло повысить интеллектуальный потенциал, научно-философский гений нашего народа жившего на берегах рек Амударья и Сырдарья, его выдающиеся деятели, такие как Хорезми, Фергани, Бухари, Термизи, Фараби, Беруни, Ибн Сина, Замахшари, Улугбек, Алишер Навои, Бабур, запечатали свои имена на страницах мировой цивилизации и культуры.

Вместе с тем, эти философские имена отражают благородные идеи, доктрины и теории, которые эти великие предки создали и развили в истории нашей нации навсегда, философия эпохи, где четко показаны всему миру в значительной степени подъем культуры и духовности нашего народа. Это философия периода, когда во главе широкой массы народа были такие герои как Муканна и Жалолоддин Мангуберди, одновременно ведя борьбу за свободу поднимая настроение народа вдохновляли его к великим целям, эпоха формирования благих намерения.

История философии нашего народа, ставшего основой этой темы, конечно, связана арабским завоеванием и с появлением исламской религии. Но как утверждают некоторые зарубежные специалисты, не только одна часть исламской культуры, возникшее под его воздействием событие не временное и незначительное. Возможно это – сохранил самосознание и в самые опасные периоды истории, хотя в результате различных набегов потерял национальную государственность на какое-то время, неизбежно восстановил, никогда не терявшего традиций в этой области и чувства веры в будущее, не горящее и нетонущее ценность нашего народа, постоянное мировоззрение и неотделимый образ мышления. В том смысле, хотя наша страна в начале этой эпохи была в тисках арабов, а конце монголов, философия нашего народа, несмотря на недостатки, присущие этим вторжениям, не потерял высокого духовного значения, сохранил ценность и значение. И поэтому, гений нашего народа этой эпохи из-за стремлений и действий, идей и учений наших предков, создал духовность и философию оказавшие весьма большое воздействие не только на исламскую религию и учение, но и на всю мировую цивилизацию и мышление народов мира.

И вот почему неспроста сегодня во всем мире оказывается почёт и уважение немеркнущему гению великих наших предков, растущий интерес к изучению их богатого научного наследия. Об этом свидетельствует тот факт, что статуи Ахмеда Фаргони в столице Египта Каире, Ибн Сина в Бельгии, Мирзо Улугбекка в Литве и Алишер Навои в Москве, Токио и Баку являются свидетельством памяти нашего деда и пробуждает в наших сердцах безграничное чувство гордости.

Изучение предмета позволяет предположить, что особенности узбекской философии того времени были связаны со многими историческими и духовными факторами и сложными общественно-политическими процессами. Среди этих факторов становится ясным, что идеи и действия нашего народа, борьба за стремление к свободе, достижение независимости, восстановление национальной государственности и её укрепление являются приоритетными. В этом смысле, цель изучения данной темы – формирование таких добродетелей как укрепление воли молодёжи, воспитывать их как образованных людей с независимым мышлением, самосознание и память о прошлом, сохранение и почитание священных ценностей наших предков.

Среди трудов посвященных этому периоду узбекской философии и последующих этапов совершенствования, вопросам философского наследия наших ученых предков “Звезды духовности” (2001), “Страницы из истории мировой философии” (2004) также книги изданные международным центром Имама Бухари “Узбекистан – страна великих ученых” (2011), стоит отметить моменты, изложенные в научно-популярных брошюрах в категории «Мыслители».

Теме жизни и творчества ученых того времени, их месте и значении в узбекской философии посвящены исследования таких ученых как М.Хайруллаев, О.Файзуллаев, Х.Аликулов, Р.Носиров, У.Уватов, М.Кодиров, Б.Тураев, А.Ахмедов, М.Зохидов, М.Жакбаров, О.Жураев и др. Мы кратко анализируем эту тему на основе работ этих авторов и ряда других специалистов.

Как известно, оккупация Центральной Азии в VII-VIII веках и ее подчинение арабскому халифату сильно повлияли на сознание и мышление нашего народа и последующую практику национальной философии. В конце VIII-века возникло единое царство на основе исламской религии, которая объединила разные народы и нации от Атлантического океана до Тянь-Шаня, Индийского океана и до Кавказа. Но этот процесс был нелегким. Завоеватели столкнулись с древней наукой, культурой и религиозными традициями, которые были высоко развиты в завоеванных странах. Они раздули борьбу против этих традиций, не подходящих исламским столпам, уничтожили людей, знающих древние письмена. В ответ в различных регионах произошли различные восстания во главе с Абу Муслимом, Хамзой аль-Хорижем, Муканной, Рафи ибн Лайзом. Особенно, восстание «Людей в белых одеждах» во главе Муканны потрясло арабский халифат. И только к концу VIII-века халифат смог полностью установить свое господство.

В этот период в центрально-азиатский регион состоял из таких стран, как Хорезм, Согд, Фергана, Усрушана, Чаганян, расположен в многолюдном центре «Шелковый путь» связывающий Восток с Западом и более развит с культурной стороны, сельское хозяйство и ремесла разнообразны, состоит из регионов с развитыми торговыми связями с близкими и далекими странами. Многолетние политические и экономические процессы, научные и культурные взаимодействия по-разному воздействовали жителей разных регионов халифата. Если в таких странах как Ирак, Сирия, Египет и страны Запада в результате ассимиляции в центральных и западных землях арабизировалось население этих стран, народы Центральной Азии, Ирана и Кавказа не были подвержены этой ассимиляции. Напротив, они смогли общаться и сотрудничать с другими народами на языке халифата, внося неоценимый вклад в сокровищницу мировой культуры и в то же время обогащая их культуру и философию, сохраняя при этом свою национальную самобытность. Это позволило им развить множество школ философии и национальной философии и сделать много изобретений в перспективных областях исследований.

Стоит отметить еще один момент, войдя в Согдийскую, Хорезмскую, Самаркандскую, Бухарскую, Ферганскую, Иранскую и другие страны с древней культурой, арабы овладели особенностями и институтами образа жизни города, и элементами культуры. В этом смысле английский востоковед У. Монтгомери Уотт писал: «Нет ничего удивительного в том,

что древняя культура Востока стала мусульманской. Удивительно, но новые завоеватели позже утверждали, что все, что они приобрели, было их собственным с древних времен, и те, кто следовал за ними, пошли тем же путем». Известно, что основа исламского учения изложена в Коране и хадисах. Коран – священная книга. В ней нашли свое выражение принципы ислама, требования веры, правовые и этические нормы. А «Сунна» является комплексом хадисов, стоит после Корана и дополняет его. В ней собраны слова, действия пророка Мухамеда в форме преданий и хадисов. Важный источник после Корана и сунны является шариат. Шариат (правильный путь, божественный путь) – система правовых, нравственных норм и практических требований в исламе. Основные направления в исламе – суннизм, шиизм, иностранцы. Они различаются по вопросам, связанным с религиозной доктриной, ритуалом и нравственно-правовыми нормами. Как сторонники первого течения в исламе возникло движение иностранцев (с арабского - мятежник). В средние века направление иностранцев было разделено на множество ручьев, а затем исчезло. Сохранилось только течение ибодиев (абодиев).

Сектантство сформировалось в результате разногласий по богословским вопросам. В исламе существуют такие секты как ханафизм, ашаризм, жабаризм, каризм, сифатиизм, муржиизм, мутазилиизм. Кадрианцы защищали свободу воли народа и выступали против евангелистов, которые не признавали этого. Мутакалимы пытались оправдать религиозно-догматическую доктрину ислама, используя методы и средства аристотелевской философии. Мутазилиисты (секуляристы) отстаивали справедливость единобожья, создание Корана Богом, свободу воли. Его основатель – Васил ибн Ато (699-748 гг.), один из последних представителей – Замахшари.

Бок о бок с этими процессами в исламе сформировались философские взгляды машшоюнов и материалистов (философия Аристотеля и тех, кто решил изучать природу). Это показывает, что исламская духовность является инициативной силой как в светских, так и в религиозных делах, а также в процессах, происходящих в мировом философском мышлении. Если в древнегреческой философии традиционно политическая деятельность и мудрость во многих случаях противопоставляются друг другу, в исламской философии, напротив, политика рассматривается как высшая форма человеческой деятельности. В исламе государственное управление – это искусство, но оно должно следовать принципу социальной справедливости, и социальная справедливость может быть поддержана через равенство.

Согласно исламской философии, будущее человечества определяется формированием совершенного человека, а мораль является неотъемлемой частью человеческого мышления. Восточные мыслители давно интересовались статусом разума и логики, потому что любое знание, не

основанное на логике, не может быть надежным и эффективным. И этот вопрос имеет свое место в исламской философии

Религиозная терпимость и светские знания. Если в те времена лидерами на поприще религиозных наук были имам Бухари, имам Термези, имам Мотрудии имам Бухониддин Маргинони, то на поприще мировых знаний Аль-Хорезми, Аль-Фергани, Фараби, Аль-Беруни, Ибн Сина распространили в ми славу нашей страны. Пушит и будут писать о том, как эти люди повлияли на историю человечества и нашего народа, об обогащении наше национальное наследие своим творчеством. Так как гениальность каждой нации ясно проявляется в работе исторических деятелей, ученых и мыслителей, а также в их идеях и учениях. В этом смысле идея о том, что «Великие люди представляют гений народа», приписываемые Дж. Неру, представляет реальность жизни.

Абу Абдулла Мухаммед ибн Исмаил аль-Бухари (810.21.7. Бухара-870.31.8. село Хартанг близ Самарканда), один из выдающихся ученых, которые продемонстрировали гениальность нашего народа и оказали большое влияние на исламскую философию и национальную мысль, хорошо известен в истории мировой философии как известный ученый хадисовед и философ. Произведение мыслителя «Аль-Жоме ас-сахих» первая из шести общепризнанных книг. Такие книги учёного как «Ат-Тарих аль-кабир», «Ат-Тарих ас-сагир», «Аль-Адаб ал-Муфрад» («Шедевры воспитанности»), «Ат-Тафсир аль-кабир» («Великое толкование»), «Китоб аль-Фавойид» («О пользе»), «Сунан аль-Фукахо» тоже известны и знамениты.

По сведениям У.Уватова, досконально изучившего творчество мыслителя, в воспитании Аль-Бухари как известного ученого помимо семейного воспитания и медресе имеют место и великие заслуги наставников. Как вспоминал сам ученый «Я записал хадисы у 1080 мухаддисов». По словам нашего ученого предка Беруни Аль-Бухари жил в «период усиления способности запоминания», продукт того времени, выражал его облик и был самым проницательным мыслителем. Из тысяч хадисов, которые он написал и запомнил на протяжении всей своей жизни, он извлек самые надежные 7275 и включил их в книга «Аль-жомеъ ас-Сахих». По его словам, он выучил более 100 000 хадисов и писал эту великую работу в течении 16 лет.

«Аль-Джами ас-Сахих» является таким великим духовным сокровищем, что подлинные хадисы, которые следуют за ним, служат основой для правил шариата в познании исламского шариата, калама и фикха после стихов Корана. Мы здесь можем увидеть, что некоторые из хадисов в этом сборнике составляют основу современного естествознания. Например, в книге «Мудрости о воде» приведен священный хадис о возникновении всех растений и всего живого из воды. Изучение имущества вакуфа, права наследников, науки и просвещения было источником хадисов

об обязанностях всех мусульманских мужчин и женщин, а также постановлений шариата и фетв судей по важным жизненным вопросам.

Многие другие работы ученого также посвящены актуальным вопросам философии того времени. Возьмем, к примеру, «Аль-Адаб аль-Муфрад», в котором аль-Бухари классифицировал хадисы о человеческой морали, этике и духовной зрелости по различным темам и дал необходимые объяснения.

В первых главах работы на основе хадисов обсуждаются важные вопросы, связанные с духовной жизнью человека, такие как обязанности ребенка перед родителями, угождать родителям, выполнять их права, подчиняться приказам родителей, делать им добро, даже если родители политеисты, не ранить их сердца, молитвы родителей, любовь и милосердие к родственникам, сострадание, милосердным и гуманным к детям и женщинам, примирение во время конфликта между детьми и взрослыми, скромность в строительстве здания и других работах, вред высокомерия и брани, вред угнетения, честность и обман, дозволенный и недозволенный, добро и греховные дела, благо экономии и приумножении имущества.

И великие учителя, обучавшие Имама аль-Бухари хадисам, вскоре начали признавать себя его учениками. В детстве его учитель Исхак ибн Рахвайх говорил Иمامу аль-Бухари: «Вы рассказывайте (хадис), а другие пишут». А его учитель Абдулла ибн Мунир говорил: «Я один из учеников аль-Бухари». Его современник, знаток хадисов Абдулла ибн Абдуррахман Самарканди, сказал: «Я видел много ученых в двух Хараме (Мекке и Медине), в Хиджазе, в Дамаске и в Ираке, но я не видел никого, кто собирал хадисы, как Мухаммад ибн Исмаил (много и достоверно). Это человек осведомленнее, беднее и требовательнее, чем мы».

Помимо написания редких работ в жизни Имам аль-Бухари также воспитал много замечательных учеников. Среди них есть такие выдающиеся исследователи хадисов и комментаторы, как Абу Иса ат-Термизи и Муслим ибн Хаджадж. В Нишапуре он жил с ат-Термизи в одном месте и в течении пяти лет сотрудничал в области науки и творчества. Известный знаток хадисов Фараби говорит: «Число людей, которые услышали только книгу «Аль-Джаме ас-Сахих» от этой великой личности, составило девяносто тысяч».

Несомненно, что духовные шедевры относящиеся в наследию Аль-Бухари, Ат-Термизи, научные идеи, выдвинутые в трудах Мусы аль-Хорезми, Ахмада аль-Фергани, естественнонаучные и философские взгляды Фараби, Беруни, Авиценны, новые направления в науке, суфийские учения, оказали жизненно важное влияние на развитие философской мысли на Востоке и в мире. Вместе с тем, в этот период влияние цивилизации нашей страны на развитие народов Востока, арабской культуры и исламской философии было огромным. Создание на его территории государств, получивших относительную независимость от Арабского халифата,

достигло новых высот благодаря терпимости нашего народа. Культурно-духовный подъем в светской и религиозной сферах – яркий символ этого периода пробуждения. Традиции Авесто, достижения в изучении природы, позитивные достижения в гуманитарных науках оказали глубокое влияние на развитие народов Востока, арабской культуры и исламской философии. Духовный и интеллектуальный престиж нашей Родины вырос в мире, она превратилась в крупный научный центр в мире.

К сожалению, это культурное пробуждение пришло в упадок из-за нашествия монголов. Конфликты между эмирами и султанами привели к вторжению Чингисхана. Это нашествие началось с завоевания Монголами Отрара в 1218 году, пленения его правителя, зятя Хорезмшаха Инольчика, и заливки ему в уши кипящего серебра. Во время правления монголов такое кровопролитие не утихало. Красивые города и села нашей страны разорены, экономика рухнула. Наука, культура и философская наука также находились в кризисе.

Многие люди были вынуждены покинуть земли между Амударьей и Сырдарьей, то есть свою родину, и жить вдали от нашей страны. Многие из них не вернулись из других земель, и их предки слились с туземцами. Аналогичная судьба постигла и семью великого поэта Амира Хусрава Дехлави (1253-1325), жившего в то время в Индии. В годы, когда Чингисхан завоевал город Отрар и начал захватнические походы, семья присоединилась к каравану из Шахрисабза в Индию и поселилась там. Безусловно, его предки, родившиеся и выросшие в нашей стране, оказали большое влияние на формирование мировоззрения и мышления ученого, вошедшего в мировую литературу со многими бессмертными произведениями, такими как «Хамса», «Чудеса Хисрава». Хусрав Дехлави, поднявшийся до уровня одного из самых известных поэтов Востока, в своих произведениях пролил свет на многие философские и нравственные проблемы, воспел высокие духовные чувства, такие как дружба, отвага, преданность, терпимость. Как поэт и мыслитель-гуманист, он призывал людей разных вероисповеданий объединяться и жить в мире. Его мысли по этому поводу отражают благородные идеи узбекской философии, влияние мировоззрения и образа мышления нашего народа.

По мнению некоторых ученых и экспертов, знающих историю человечества, если бы Хорезмшах с самого начала назначил наследником престола своего отважного сына Джалалиддина и передал ему армию, не только история Азии, но и история мира могла бы пойти иначе. К сожалению, история не признает таких утверждений, как «Если бы не это, это могло бы быть ...». Нашествие Чингисхана задержало развитие нашей страны на несколько столетий. Джалолиддин Мангуберди, храбрый и отважный человек, сражавшийся в то время с захватчиками, навсегда остался на страницах нашей истории как символ движения за освобождение нашего народа.

Следует отметить, что принцип объективности и толерантности играет важную роль в изучении средневековой философии. Преданность и терпимость наших великих предков, общность светских и религиозных наук в их мировоззрении и их терпение являются примером для всех нас. Это богатое духовное сокровище служит для прививания в сердца и умы населения, особенно молодежи, благородных идей и принципов высокой духовности, призывает их мыслить независимо, жить для народа, для своей страны.

Сегодня независимость дала возможность изучение богатого и бессмертного наследия, созданного нашими предками, его сохранения и довести до будущего поколения. Восстановление исторической памяти, формирование чувств верности, патриотизма в отношении национальных ценностей в душе нашего народа стали сегодня приоритетным направлением нашей духовной жизни. А это возлагает на каждого из нас огромную ответственность.

Использованные источники:

1. Каримов И.А. Обеспечение поэтапного и устойчивого развития нашей страны – наша главная цель. –Т. 17. –Ташкент: Узбекистан, 2009. –с. 137.
2. Звёзды духовности. Издательство народного наследия имени А. Кадыри. Т-2001 й.75-с.
3. Григорян С.Н. Великие мыслители Средней Азии. Издательство «Знание», М.: 1958.
4. Григорян С.Н. Из истории философии Средней Азии и Ирана VII-XII вв. М.: Издательство АН СССР 1960.
5. Кохановский В.П., Матяш Т.П., Яковлев В.П. Основы философии - Ростов-на-Дону Феникс, 2007.-320с;
6. Крянев Ю.В., Моторина Л.Е. История и философия науки (Философия науки) - Москва Альфа-М, ИНФРА-М, 2007. -336с;
7. Алексеев, П. В. Философия: учеб. / П. В. Панин, А. В. Панин. - М. : ТК Велби, Проспект, 2008;
8. Философия: учеб. пособие для высших учебных заведений / отв. редактор В. П. Кохановский. - Ростов н/Д: Феникс, 2008;
9. Кармин, А. С. Философия: учеб. для вузов / А. С. Кармин, Г. Г. Бернацкий. - СПб. : Питер,2009;
10. Философия: учеб. / под ред. В. Д. Губина, Т. Ю. Сидориной. - 4-е изд., перераб. и доп. - М. : Гардарики, 2007.

Қаххаров М.М.

доцент

Мўминжонов М.М.

ассистент

Наманганский инженерно-технологический институт

Узбекистан, Наманган

ТЕОРИЯ ПЕРКОЛЯЦИИ И КЛАСТЕРЫ

Аннотация: Рассмотрена теория перколяции, которая позволяет выразить процессы различной природы, при этом один из параметров системы постепенно изменяется (концентрация чего-либо), изменяется свойство системы. Такая простая модель способна адекватно представить, например, фазовый переход парамагнетиков в ферромагнетики, процесс эпидемий, лесных пожаров.

Ключевые слова: кластеры, перколяция, фазовый переход, композитные материалы.

Kakhkharov M.M.

associate professor

Muminjonov M.M.

assistant

Namangan Engineering Technological Institute

Uzbekistan, Namangan

PERCOLATION THEORY AND CLUSTERS

Annotation: The theory of percolation is considered, which allows expressing processes of different nature, while one of the parameters of the system gradually changes (concentration of something), the property of the system changes. Such a simple model is able to adequately represent, for example, the phase transition of paramagnets into ferromagnets, the process of epidemics, forest fires.

Key words: clusters, percolation, phase transition, composite materials.

Основная задача полимерной матрицы при создании композитные материалы(КМ) структурного назначения - регулировать функцию волокон, обеспечивать равномерное распределение напряжений между волокнами и защищать их поверхность от повреждений. Поэтому к связующим (матрицам) конструкционных плит предъявляются следующие требования.

Наполнитель должен обладать хорошей адгезией к поверхности, высокой прочностью и рядом других свойств, позволяющих осуществлять

технологические процессы при производстве КМ, т. Е. С необходимой степенью адгезии к пропитываемым элементам, смешиванию с дисперсными наполнителями. , допускайте термостойкость при приготовлении продукта и так далее.

Термо- и реактопласты используются в качестве матрицы при производстве КМ с различными свойствами, и во многих случаях вопросы механической прочности не считаются решающими. В некоторых случаях матричные пены могут быть приемлемыми с точки зрения долговечности. Хотя существует большая разница между коэффициентами теплового расширения матрицы и наполнителей, в отличие от конструкционных композитов, их нельзя считать невозможными.

Это также гарантирует, что требуемые электрические свойства зависят от температуры.

К первым задачам при выборе полимерной матрицы относятся параметры, определяющие распределение в ней частиц наполнителя, как было сказано выше, технологические соображения (адгезия, термическая стабильность), а также наличие фазовых переходов, влияющих на термическое связывание различных электрических свойств тела [15], [19].

Обычно зависимость проницаемости от концентрации наполнителя в композитах объясняется теорией перколяции.

Первоначально слово «перколяция» использовалось для противопоставления диффузии. Случайное движение частиц в диффузно регулярной среде мы понимаем регулярное движение (например, ток или поток жидкости) в случайной среде в случае перколяции. Предположим, что свойства электропроводности композитных материалов с квадратным размером 3x3 перенесены в сетку и часть квадрата закрашена в черный цвет.

В нашем случае их 3. Процент закрашенных квадратов $p = \frac{1}{3}$ будет. Эти квадраты можно выбирать независимо и случайным образом], [или к этому можно добавить какое-то правило. Первый случай называется случайной перколяцией (математики называют ее перколяцией Беруни). Вторым случаем называется коррелированной перколяцией. Один из ключевых вопросов, на который должна ответить теория перколяции, - как работают эти нарисованные квадраты. p_c образуется цепочка черных квадратов, соединяющая верх и низ сетки. Рисунок 2-1. Легко сказать, что для сетки конечных размеров такая цепочка встречается при разных концентрациях (рис. 2.1). Если стремиться к бесконечности размеров сетки, то возникает критическая концентрация p_c будет полностью определен (рисунок 2.2). Такая критическая концентрация, которая твердо доказана, называется пределом перколяции или переходом, скачком.

В случае, когда вставлен электропроводящий наполнитель, он остается изоляционным материалом до тех пор, пока не образуется цепочка проводящих частиц, соединяющая верх и низ образца.

Если смотреть на черные квадраты как на молекулы, то образование цепочки молекул, проходящих через всю систему, соответствует образованию геля.

Если черные квадраты называют микротрещинами, то образование такой цепочки трещин приводит к растрескиванию.



Рисунок 1. Заливка гриля в разных вариантах

Проблема теории восприятия - это физика анализируемой среды. и определим соотношение геометрических характеристик. Простыми, но наиболее изученными являются конструкции на основе регулярных сеток. Для них обычно рассматривается вопрос узлов и вопрос садов. Они возникают, когда определенная часть случайно выбранных узлов сетки (рис. 2.1) удаляется из узла (вместе с их связями) при рассмотрении физических свойств сетки (называемых свойством электропроводности для точности). Или удалите долю случайно выбранных садов. В случае с садами главное найти ответ на вопрос, какой долей снимать (обрезать) огород, чтобы сетка разделилась на две части.

В проблеме с узлом узлы блокируются (узел удаляется, а все ссылки на этот узел обрезаются) и какой процент заблокированных узлов разбит на сетку.

Квадратная сетка - это всего лишь один вид возможных моделей. процессы также можно увидеть в сетках.

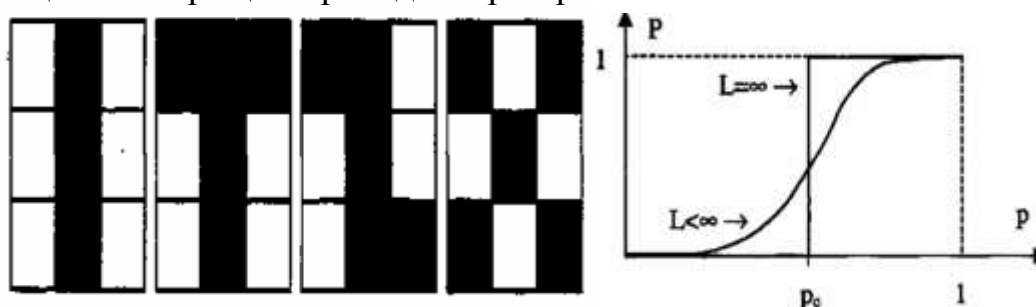

Рис. 2. Проблема узлов (а) и квадратной сетки садовый вопрос (б)

В теории перколяции черных квадратов цепочка связанных объектов, например, называется кластером (кластер - кластер, кластер, множество).

Кластер, соединяющий две противоположные стороны системы, называется перколяцией, бесконечностью, сжатием или связыванием.

Перколяционный переход состоит из геометрического фазового перехода. В этом случае предел перколяции или критическая концентрация делится на две фазы. Ограниченные кластеры в одной фазе будут иметь один бесконечный кластер в другой. Наиболее подходящей проблемой перколяции для выражения электрических свойств композитных материалов являются те, которые созданы для этой непрерывной среды. По этому вопросу $p = v_f$ в каждой точке космоса $\sigma = \sigma_f$ с проводимостью и вероятностью $1-p$ $\sigma = \sigma_m$ отвечает проводимость.

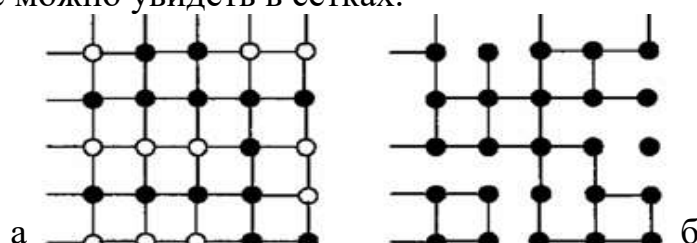
Здесь индекс f представляет наполнитель, а индекс m представляет матрицу. Предел считывания (v_f^*) в этом случае равен минимальному проценту пространства, занимаемого проводящими сферами, и в этом случае система остается проницаемой. Электропроводность композита v_f Изменение значения составляет от 0 до 10. σ_m и σ_f а это обычно 20 порядков. σ Увеличение происходит монотонно, наиболее резкое изменение которого обычно наблюдается в узком диапазоне концентраций наполнителя. Это позволяет говорить о переходе диэлектрик-металл или иначе v_f называется перколяционным переходом, когда он равен пределу обучения. Этот переход называется фазовым переходом второго раунда.

Использованные источники:

1. Пруамова Т.Д. Ролдугин В.И. Профодимость металлонаполненных полимерных пленок вблизи порога протекание // Коллоид. Журн. – 1992, - т. 54. - № 5, с. 109-113
2. D.P.H. Smith and J.C. Anderson, Electrical conduction in thick film paste resistors / Thin Solid films, 1980, V. 71, N. 1. - p. 79-89.
3. Lietnerski B.W. / Conduction mechanism in thick-film resistors // Rr. naux, Inst. technal, electron. prod. - 1986, - N 34. - p. 4-17.
4. Н.Ю.Шарибаев, А.Эргашев, А.Мамадалиев, Р.Н.Шарифбаев, С.Х.Киргизова, Исследование спектра рассеяния света использованием дельта-функций // Экономика и социум №12(67) 2019 https://iupr.ru/osnovnoy_razdel_12_67_2019/.
5. А.Эргашев, Э. Шарибаев, Б.Хайдаров, Д. Тухтасинов, Устройство соединений -защита от слабых контактов// Экономика и социум №12(67) 2019 https://iupr.ru/osnovnoy_razdel_12_67_2019/ (ОАК,11.00.00-МДХ №11)
6. Д.Р.Отамирзаев, Э.Ю.Шарибаев, Солнечный фотоэлектрический преобразователь и температура его поверхности// Экономика и социум №12(67) 2019 с

7. Д.Ж.Холбаев, Г.Д.Дехконов., Электрохимическая активация водных сред// Экономика и социум №12(67) 2019
https://iupr.ru/osnovnoy_razdel_12_67_2019/

*Қаххаров С.С.
доцент*

*Баҳромов Б.М.
ассистент*

*Наманганский инженерно-технологический институт
Узбекистан, Наманган*

ПОЛИМЕРНЫЕ КОНСТРУКЦИИ КОМПОЗИТНЫХ МАТЕРИАЛОВ

Аннотация: Исследована граница Винера - это очень грубая оценка проницаемости, поскольку она игнорирует топологию композита, связь между частицами наполнителя и другие факторы. Однако он позволяет оценить диапазон изменения проводимости для конкретной пары композиционных материалов и оценить другие транспортные характеристики

Ключевые слова: композитные материалы, проводимость, граница Винера, оценка проницаемости.

Kakhkharov S.S.

Associate Professor

*Baҳromov B.M.
assistant*

*Namangan Engineering Technological Institute
Uzbekistan, Namangan*

POLYMER STRUCTURES OF COMPOSITE MATERIALS

Annotation: The investigated Wiener boundary is a very rough estimate of the permeability, since it ignores the topology of the composite, the relationship between the filler particles, and other factors. However, it allows one to estimate the range of conductivity variation for a specific pair of composite materials and to estimate other transport characteristics

Key words: composite materials, conductivity, Wiener boundary, estimation of permeability.

Причиной внедрения наполнителей для изготовления композитных материалов (КМ) конструкционного назначения является получение полимерного материала с комплексом улучшенных физико-механических свойств. Волокнистая, чтобы достичь этого критик необходимо добавить наполнители, мелкодисперсные наполнители, разрезанные стекловолокна, наноразмерные органические или неорганические частицы и так далее.

Чтобы создать КМ с особыми свойствами, обычно вводятся наполнители, чтобы придать материалу требуемые электрофизические, термические, сенсорные и другие свойства в дополнение к механическим свойствам. В этом случае частицы наполнителя так или иначе распределены в полимерной матрице. По распределению компонентов композиты можно разделить на матричные (регулярные) системы, статистические смеси и структурированные композиты.

На рис. 1. показаны различные структуры композитов и распределение наполнителя в матрице. В матричных системах частица наполнителя находится в узлах регулярной (а) сетки. В статистических системах компоненты распределены хаотично и не образуют регулярной структуры (б). В систему структурированных композитов входят те, компоненты которых образуют цепные, плоские или объемные структуры (v, g).



Рисунок 1. Состав состава и распределение наполнителей в матрице.

Топология КМ относится к распределению дисперсной фазы в соответствии с формой частиц дисперсной фазы, их размером и объемом дисперсной среды. Также включены размеры входов, расстояние между ними, центральная координата входов, угол направления в фазе входов неоднородного размера, то есть размеры входов в одном или двух отдельных направлениях. намного больше, чем в другом направлении. Например, для него также характерны волокна, пластины и т. Д.

Сплошные волоконные или тканевые композитные материалы, ориентированные по одной оси, легко подвергаются анализу (рис. 2).

Например, электропроводность КМ в направлении вдоль волокна (в плоскости слоя ткани) (будет рассмотрено в будущем)

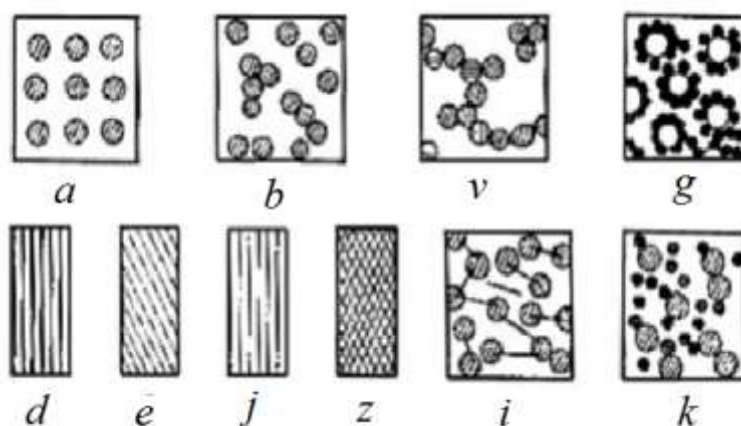
$$\sigma_c^{eff,1} \leq p\sigma_f + (1-p)\sigma_m \text{ (Верхний предел Винера)} \quad (1)$$

а электропроводность в перпендикулярном направлении

$$1 / \sigma_c^{eff,2} \leq p / \sigma_f + (1 - p) \sigma_m \quad (\text{Нижняя граница Винера}) \quad (2)$$

определяется как. Это оно на земле σ_f и σ_m - электропроводность наполнителя и матрицы, p - объемная доля наполнителя. Эти выражения носят общий характер, поскольку фазовые эффекты соответствуют эффективной проводимости двухфазной системы, когда они включены последовательно и параллельно, а оптимизация достигается, когда известна объемная доля каждой фазы.



Рисунок 2. Два граничных состояния в микрогеометрическом размещении наполнителя. Электропроводность определяется верхней границей Винера в направлении параллельных слоев. Он определяется нижней границей Винера, перпендикулярной слоям.

Продольная проницаемость для слоистых композиционных материалов σ_1 всегда больше, чем проницаемость в направлении, перпендикулярном слою. Конечно, σ_3 σ_i проницаемость и d_i продольная проницаемость для набора слоев толщиной:

$$\sigma_1 = \sum d_i \sigma_i, \quad (3)$$

Поперечная проводимость составляет:

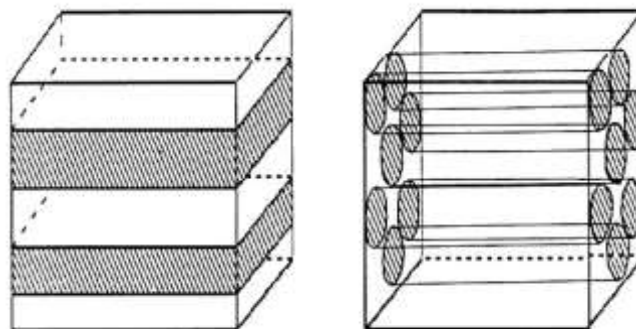
$$\frac{1}{\sigma_3} = \frac{\sum d_i}{\sigma_i} \quad (4)$$

Средняя продольная проницаемость:

$$\sigma_{eff,1} = \frac{\sigma_1}{\sum d_i} \quad (5)$$

Средняя поперечная проводимость:

$$\frac{1}{\sigma_{eff,3}} = \frac{\sum d_i}{\sigma_3} \quad (6)$$

Используя неравенство Коши-Буняковского,

$$\sigma_{eff,3} < \sigma_{eff,1} \quad (7)$$

выражается.



Рис. 3. Эффективная электропроводность композита $\frac{\sigma_{eff}}{\sigma_m}$ и концентрация наполнителя для верхнего и нижнего предела Винера ($\frac{\sigma_f}{\sigma_m} = 10$ случай).

Электропроводность в направлении параллельных слоев определяется по верхней границе Винера. Электропроводность вдоль перпендикулярных слоев определяется между нижним пределом Винера. Верхний и нижний предел Винера определяет значения электропроводности КМ в заданном соотношении параметров матрицы и наполнителя, независимо от формы частиц и метода приготовления КМ (рис.3).

Использованные источники:

1. Гантмахер В.Ф. Электроны в неупорядоченных системах., М. Наука, 2003, 176 с.
2. Забродский А.Г., Немов С.А., Равич Ю.И. Электронные свойства неупорядоченных систем., Спб. : Наука, 2000, - 72 с.
3. Забродский А.Г. Кулоновская щель и фазовый переход металл-изолятор в легированных полупроводниках. // УФН.- 1998.- Т. 168. - № 7. - с. 804-808.
4. Н.Ю.Шарибаев, А.Эргашев, А.Мамадалиев, Р.Н.Шарифбаев, С.Х.Киргизова, Исследование спектра рассеяния света использованием дельта-функций // Экономика и социум №12(67) 2019 https://iupr.ru/osnovnoy_razdel_12_67_2019/.
5. А.Эргашев, Э. Шарибаев, Б.Хайдаров, Д. Тухтасинов, Устройство соединений -защита от слабых контактов// Экономика и социум №12(67) 2019 https://iupr.ru/osnovnoy_razdel_12_67_2019/ (ОАК,11.00.00-МДХ №11)
6. Д.Р.Отамирзаев, Э.Ю.Шарибаев, Солнечный фотоэлектрический преобразователь и температура его поверхности// Экономика и социум №12(67) 2019 с

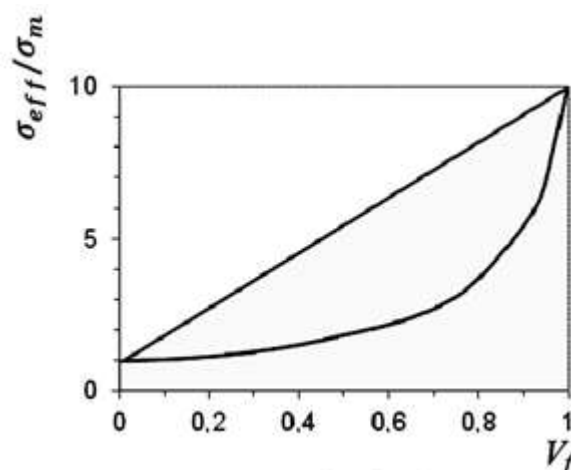
7. Д.Ж.Холбаев, Г.Д.Дехконов., Электрохимическая активация водных сред// Экономика и социум №12(67) 2019
https://iupr.ru/osnovnoy_razdel_12_67_2019/

*Қодиров Р.Ш.
Мамазулунов Н.Х.
Ботиров Э.Х.
Юсупов М.М.*

Андижанский государственный медицинский институт

ФЛАВОНОИДЫ RUSSOWIA SOGDIANA (BGE). FEDSCH

Аннотация: В этой статье ФЛАВОНОИДЫ RUSSOWIA SOGDIANA (BGE). FEDSCH и значения входящих в его состав веществ в медицине, дана информация о лекарственных растениях.

Ключевые слова: Флавоноиды Russowia sogdiana, апигенин, кверцетин, изорамнетин, кверцетин-7-0-β-d-глюкопиранозид, изорамнетин-7-0-β-d-глюкопиранозид.

*Kodirov R. Sh.
Mamazulunov N. Kh.
Botirov E. X.
Yusupov M. M.
Andijan State Medical Institute*

RUSSOWIA SOGDIANA (BGE) FLAVONOIDS. FEDSCH

Abstract: In this article, RUSSOWIA SOGDIANA FLAVONOIDS (BGE). FEDSCH and the importance of its constituent substances in medicine, information on medicinal plants is provided.

Key words: Russowia sogdiana flavonoids, apigenin, quercetin, isorhamnetin, quercetin-7-0-β-d-glucopyranoside, isorhamnetin-7-0-β-d-glucopyranoside.

Ученые всего мира в настоящее время проявляют колоссальный интерес к флавоноидам лекарственных растений, что обусловлено их высокой биологической активностью, широтой терапевтического эффекта и малой токсичностью [1-4]. Флавоноиды привлекают внимание исследователей как физиологически активные вещества с разносторонним спектром действия. Они являются важными и даже наиболее активными действующими началами растений и растительных препаратов, используемых в народной и научной медицине в качестве желчегонных, противовоспалительных, спазмолитических, противоаллергических и сосудорасширяющих средств [1,4]. В результате проведенных в последнее время исследований получены препараты гипоазотемического, гипогликемического и противовирусного действия [4]. Однако препаратов, содержащих

флавоноиды, пока имеется немного. Чаще эти соединения находятся в растениях в комплексе с другими БАВ и используются суммарно. Следовательно, поиск новых источников флавоноидов с целью их практического использования относится к актуальным задачам.

Из литературных данных известно, что многие представители растений семейства *Asteraceae* богаты биологически активными флавоноидами [4,6]. *Russowiasogdiana*(Bge). Fedtsch(руссовия согдийская) относится к данному семейству и представляет собой однолетнее травянистое растение, встречающийся на выходах пестроцветных пород в нижнем поясе гор Средней Азии, долины рек Зеравшан, Сырдарья, Кызылкум, Каракум. [6].

Растительное сырье (надземная часть *Russowiasogdiana*) для исследования заготовили собрано в середине мая 2016 г. в период цветения в окрестностях г. Ферганы Республики Узбекистан. Высушенную и измельченную надземную часть экстрагировали при комнатной температуре 96%-ным этанолом. Объединенный экстракт сгущали в вакууме, разбавляли водой в соотношении 1:1. Водно-спиртовой экстракт последовательно подвергали жидкость-жидкостной экстракции петролейным эфиром, хлороформом, этилацетатом и н-бутанолом.

Этилацетатную фракцию хроматографировали на колонке (180 x 3,5 см) с силикагелем в градиентной системе растворителей хлороформ-пропанол-2. Собирали фракции по 400 мл. При элюировании колонки смесью хлороформ-пропанол-2 в соотношении(92:8) из отдельных фракций после рехроматографирования на колонке с сефадексом LH- 20 и перекристаллизации из этанола выделили вещества 1, 2 и 3. При дальнейшем элюировании колонки смесью хлороформ-пропанол-2 в соотношении (86:14) выделили вещества 4 и 5. Продолжая промывание колонки смесью хлороформ-пропанол-2 в соотношении (82:18) выделили вещества 6 и 7. Полученные вещества очищены дробной перекристаллизацией из различных растворителей и рехроматографированием на полиамиде.

На основании изучения спектральных данных соединения 1,6 и 7 отнесены к производным флавонола, а вещества 2-5 - к производным флавонола [6,7]. Флавоноиды идентифицировали на основании результатов кислотного гидролиза, изучением спектральных данных и сравнением физико-химических констант с литературными сведениями.

Апигенин (1). Кристаллы светло-желтого цвета состава $C_{15}H_{10}O_5$, 346-348 °С (с разл.). $C_{15}H_{10}O_5$, т.пл. 346-347 °С (с разл.), μ_{max} 270, 340 нм. Данные 1H - и ^{13}C -ЯМР спектров соответствуют опубликованным параметрам [6,7].

Кверцетин (2). Кристаллы желтого цвета состава $C_{15}H_{10}O_7(M^{+302})$ с т.пл. 313-314 °С, μ_{max} 257, 268, 372 нм. Данные 1H - и ^{13}C -ЯМР спектров соответствуют опубликованным сведениям [6,7].

Изорамнетин (3). Кристаллы желтого цвета состава $C_{16}H_{12}O_7$, M^+ 316 (100%), т. пл. 294-297 °С (водный спирт), λ_{\max} EtOH 257, 270 пл, 371 нм. 1H -ЯМР спектр (DMCO- d_6 , σ , м.д.): 3.85 (с, 3H, -OCH₃), 6.35 (д, 2,0 Гц, H-6), 6.68 (д, 2,0 Гц, H-8), 6.83 (д, 9,0 Гц, H-5') 7.69 (дд, 2,0 и 9,0 Гц, H-6'), 7.58 (д, 2,0 Гц, H-2'), 12.56 (с, 5-OH) [6,7].

Кверцетин-7-0- β -D-глюкопиранозид (4) - кристаллы желтого цвета состава $C_{21}H_{20}O_{12}$ ст. пл. 245-247 °С, λ_{\max} 257, 266, 374 нм; +NaOAc 273, 390. ПМР-спектр (ρ - d_5 σ , м.д.): 3.87-4.60 (протоны глюкозы), 5.73 (д, 6,5 Гц, H-1"), 6.69 (д, 2,5 Гц, H-6), 6.91 (д, 2,5 Гц H-8), 7.25 (д, 8,5 Гц, H-5'), 7.96 (дд, 2,5 и 8,5 Гц, H-6') и 8.50 (д, 2,5 Гц, H-2).

Гидролиз вещества 4 5%-ным раствором хлороводородной кислоты привел к получению кверцетина и D-глюкозы [7,8].

Изорамнетин-7-0- β -D-глюкопиранозид (5) - кристаллы светло-желтого цвета состава $C_{22}H_{22}O_{12}$, с т. пл. 250-252 °С, λ_{\max} 255, 271, 327, 376 нм; +NaOAc 273, 390. ПМР- спектр (ρ - d_5 , σ , м.д.) содержит сигналы при 3.77 (с, -OCH₃), 3.90-4.57 (протоны глюкозы), 5.70 (д, 6,5 Гц, H-1"), 6.72 (д, 2,5 Гц, H-6), 7.02 (д, 2,5 Гц, H-8), 7.24 (д, 8,0 Гц, H-5'), 8.08 (дд, 2,5 и 8,0 Гц, H-6'), 8.14 (с, H-2'), 13.08 (уш. с, 5-OH).

В результате кислотного гидролиза вещества 5 5%-ным раствором хлороводородной кислоты получили кверцетин и D-глюкозу [7,8].

Сапонаретин (апигенин-6-C- β -D-глюкопиранозид) (6) - кристаллы светло-желтого цвета состава $C_{21}H_{20}O_{10}$ с т.пл. 222-224 °С, λ_{\max} 272, 294, 339 нм. Спектр ^{13}C -ЯМР (DMCO- d_6 σ , м.д.): 61.4 (C-6"), 70.2 (C-2"), 70.5 (C-4"), 73.2 (C-1"), 78.9 (C-3"), 81.3 (C-5"), 93.8 (C- 8), 102.9 (C-3), 103.5 (C-10), 108.9 (C-6), 116.1 (C-3',5'), 121.3 (C-Г), 128.3 (C-2',6'), 156.4 (C-5), 160.6 (C-4'), 161.2 (C-9), 163.3 (C-2), 163.7 (C-7), 182.0 (C-4).

При окислении гликозида 6 раствором $FeCl_3$ получили апигенин и D-глюкозу [7,9].

Витексин (апигенин-8-C- β -D-глюкопиранозид) (7) - кристаллы желтого цвета состава $C_{21}H_{20}O_{10}$ с т.пл. 247-249 °С, λ_{\max} 285, 337 нм. ПМР-спектр (ρ - d_5 , σ , м.д.): 4.05- 4.55 (протоны углеводной части), 4.75 (т, 8,0 Гц, H-2"), 5.79 (д, 8,0 Гц, H-1"), 6.76 (с, H-3), 7.07 (д, 9,0 Гц, H-3',5'), 7.35 (с, H-6), 7.74 (д, 9,0 Гц, H-2',6') [7,9].

Использованные источники:

1. Тараховский Ю.С., Ким Ю.А., Абдрасилов Б.С., Музафаров Е.Н. Флавоноиды: биохимия, биофизика, медицина. Пушино: Synchronbook. 2013. 310 с.
2. Middleton E., Kandaswami C., Theoharis C.T. The Effects of Plant Flavonoids on Mammalian Cells: Implications for Inflammation, Heart Disease, and Cancer. //Pharmacol. Rev. 2000. V. 52. P. 673- 751.
3. Flavonoids in Health and Disease. /Ed. by Catherine A. Rice-Evans, Lester Packer. New York: Marcel Dekker Inc. 2003. 458 p.

4. Литвиненко В.И. Флавоноиды и лекарственные препараты на их основе. //Фармация Казахстана. 2004. Спец. выпуск. С. 16-19.
5. Флора Узбекистана. Ташкент. 1961. Т.6. С. 386.
6. Корулькин Д.Ю., Абилов Ж.А., Музычкина Р.А., Толстяков Г.А. Природные флавоноиды. Новосибирск: Академическое изд-во "Тео". 2007. 232 с.
7. Mabry T.T., Markham K.R., Thomas M.B. The systematic identification of flavonoids. New York- Heidelberg-Berlin. 1970. 354 p.
8. Чумбалов Т.К., Фадеева О.В., Никитченко Т.К. Химия природных соединений. 1974. С. 89.
9. Y. Kumarasamy, M. Byresl, P. J. Cox, A. Delazar, M. Jaspars, L. Nahar, M. Shoeb, S. D. Sarker. Isolation, structure elucidation, and biological activity of flavone 6-C-glycosides from *Alliaria petiolata*. Chem. Natur. Compounds. 2004. V. 40, №. 2. P. 122-128.

*Комилова З.Х.
преподаватель кафедры информационных технологий
Ферганский государственный университет
Узбекистан, г. Андижан
Назиржонова Ф.С.
студент
Ферганский государственный университет
Узбекистан, г. Андижан*

МЕТОДЫ ЗАЩИТЫ КОМПЬЮТЕРНОЙ СЕТИ ОТ НЕСАНКЦИОНИРОВАННОГО ДОСТУПА ИЗ СЕТИ ИНТЕРНЕТ

Аннотация: Компьютеры, сети, Интернет - неотъемлемая часть нашей повседневной жизни. Наш мир с каждым днем становится все более зависимым от информационных технологий. Сегодня каждая сеть компании имеет доступ в Интернет, это создает большие проблемы с безопасностью, поскольку для взлома компьютеров не требуется физический доступ.

Ключевые слова: проблемы безопасности, компьютер, сеть, Интернет, разработка, информационные технологии, система.

*Komilova Z.Kh.
teacher of the Department of Information Technologies
Fergana State University
Uzbekistan, Andijan
Nazirjonova F.S.
student of the Department of Information Technologies
Fergana State University
Uzbekistan, Andijan*

USE OF INTERACTIVE LEARNING TECHNOLOGIES IN TEACHING A FOREIGN LANGUAGE IN HIGH SCHOOL

Abstract: Computers, networks, Internet are essential part of our everyday life. Our world day after day becomes more and more dependent from information technology. Today each company network has access to Internet, this creates big security problems, because for computer hacking does not requires physical access.

Key words: security problems, computer, network, Internet, development, information technologies, system.

Проблемы информационной безопасности сетей современных компьютерных компаний. Уровни сетевой безопасности компании. Способы защиты компьютерной сети организации от несанкционированного доступа из сети Интернет. Информационная безопасность в сети Интернет.¹¹¹

Актуальность и важность проблем информационной безопасности объясняются следующими факторами:

- ❖ темпы развития технологий сетевой безопасности значительно отстают от развития информационных технологий в целом;
- ❖ резкое увеличение пользователей ПК во всем мире;
- ❖ высокая компьютерная грамотность населения в целом;
- ❖ значительное увеличение объема информации, которая хранится и обрабатывается компьютерами и другим оборудованием автоматизации.

По оценкам экспертов, в настоящее время около 70-90% информации и документов компаний хранятся в цифровом формате - текстовые файлы, электронные таблицы, базы данных.

Из-за конкуренции современные программные продукты поступают в продажу с ошибками и недоработками. Разработчики включают в продукт большое количество функций, но у них нет времени на отладку и тестирование созданных систем. Остающиеся в этих системах ошибки и упущения приводят к случайным или преднамеренным нарушениям информационной безопасности.

Проблемы безопасности HTTP-клиенты связаны с их расширяемостью. Поскольку веб-серверы предоставляют данные во многих форматах (текст, HTML, файлы изображений gif и jpeg, аудиофайлы и т. Д.) Для воспроизведения различных форматов, браузеры вызывают внешние приложения.

Например, чтобы просмотреть формат файла Microsoft Word, браузер вызовет Microsoft Word. Обычно браузеры предупреждают пользователя о вызове внешней программы, и этот факт необходимо подтвердить, и, как правило, люди не обращают внимания на эти предупреждения. Хотя многие форматы данных могут включать исполняемый код, например макросы в Microsoft Word и Microsoft Excel, простое представление с видом безвредных материалов может привести к выполнению кода угрозы на компьютере пользователя.

Также следует учитывать наличие «активного ингредиента» (активного содержимого), такого как Javascript, ActiveX, и т.д., которые также содержат код, выполняемый от имени пользователя.

В то же время у этого подхода есть определенные ограничения и недостатки:

¹¹¹ Маткаримова Г.А. Мультимедийные технические средства как неотъемлемая часть обучения современного специалиста. Научный электронный журнал. 2019., стр. 120.

- ❖ отсутствие доступа в Интернет с рабочего места сотрудников;
- ❖ наличие уязвимых систем, подключенных к Интернету, которые могут быть атакованы как «отказ в обслуживании» и кража услуг (в том числе называемый «безопасность на уровне сети», заключается в администрировании сле могут быть использованы для взлома других систем).

Ограничений доступа в сетях подключения, что позволяет управлять средствами защиты в точке подключения сети к Интернету, например, с помощью специальной системы - межсетевого экрана.

Межсетевой экран контролирует обмен информацией между двумя сетями и фильтрует информацию в соответствии с процедурами, установленными политикой безопасности компании. Все коммуникации между Интернетом и внутренней сетью проходят через брандмауэр. Компания может получить значительную выгоду от такой модели безопасности. Сетевой экран может защитить вас от несанкционированного доступа, не предъявляя к ним дополнительных требований безопасности.

Преимущество этого подхода - устройства защиты и контроля концентрации в одной точке, минимальное изменение внутренних процедур пользователей с информационной системой, простота администрирования и более высокий уровень защиты. Ограничением этого подхода является то, что он предназначен исключительно для защиты от внешних угроз со стороны удаленных злоумышленников.

Информационная безопасность - это непрерывный процесс проявления должной осторожности и должной осмотрительности для защиты информации и информационных систем от несанкционированного доступа, использования, раскрытия, уничтожения, модификации или нарушения или распространения. Использование межсетевых экранов - оптимальный и надежный подход, они защищают вашу компьютерную сеть от любых угроз.

Использованные источники:

1. Маткаримова Г.А. Мультимедийные технические средства как неотъемлемая часть обучения современного специалиста. Научный электронный журнал. 2019., стр. 120.
2. Информационные технологии [Электронный ресурс], 2013. - Режим доступа: <http://www.utexas.edu/its/secure/articles/firewalls.php>
3. Information System Security Associated [Электронный ресурс], 2013. - Режим доступа: <http://www.issa.org>

*Комов Д.А.
студент*

*Таланов А.Д.
студент*

*Кузнецов А.К.
студент*

*Никулин А.С.
студент*

*научный руководитель: Бабаев Д.Б., к.э.н.
доцент*

н.с.

ФГБОУ ВО ИФ РАНХиГС

ИНФОРМАЦИОННОЕ ОБЕСПЕЧЕНИЕ И ЕДИНОЕ ИНФОРМАЦИОННОЕ ПРОСТРАНСТВО В СФЕРЕ ГОСУДАРСТВЕННОГО И МУНИЦИПАЛЬНОГО УПРАВЛЕНИЯ

Аннотация: В данной статье затрагивается вопрос информационного обеспечения и единого информационного пространства в сфере государственного и муниципального управления. Анализируются работы авторов и их отношение к информационному пространству в сфере ГиМУ. Дается оценка степени правового регулирования официальных ресурсов в России.

Ключевые слова: единое информационное пространство, официальные ресурсы, система электронного документооборота, ИКТ.

*Komov D.A.
student*

*Talanov A.D.
student*

*Kuznetsov A.K.
student*

*Nikulin A.S.
student*

*Research supervisor: Babaev D.B.
IB of RANEPА*

INFORMATION SUPPORT AND UNIFIED INFORMATION SPACE IN THE SPHERE OF STATE AND MUNICIPAL ADMINISTRATION

Abstract: This article deals with the issue of information support and a single information space in the field of state and municipal administration. The

authors' works and their attitude to the information space in the field of Gimu are analyzed. The degree of legal regulation of official resources in Russia is assessed.

Keywords: unified information space, official resources, electronic document management system, ICT.

Подготовка, принятие и оценка эффективности внедрения управленческого решения для государственного и муниципального управления (ГИМУ) любого уровня должны основываться на достоверной, полной и актуальной информации. Помочь этому может формирование «единого информационного пространства» (ЕИП) для разных уровней управления. В данной обзорной статье мы попробуем классифицировать взгляды ученых по данному вопросу; для каждой категории классификации мы выбрали несколько типичных воззрений отдельных ученых (хотя здесь и нужно упомянуть, что нами сделан ряд упрощений и оговорок).

О. А. Моляренко в работе «Формальные и неформальные отношения в информационном обеспечении местного самоуправления», говорит о том, что: «В результате постсоветских реформ системы...» ГИМУ «...сложилась ситуация, при которой официальная система статистики не удовлетворяет информационные потребности органов местного самоуправления, которые испытывают потребность в статистико-аналитической информации как для нужд собственно муниципального управления, так и для удовлетворения запросов органов государственной власти (часто - непрофильных)».¹¹²

К.В. Якушенко в работе «Единое информационное пространство: теоретические подходы к содержанию понятия», детально описывает ЕИП и говорит о том, что: «Создание ЕИП открывает доступ к корпоративным базам данных и соответствующим документам, что приводит к взаимодействию знания и информации. Процесс управления знанием является необходимой ступенью для освоения ЕИП и его эффективного использования». Это можно выразить следующей понятийной схемой.

¹¹²Моляренко О.А. Формальные и неформальные отношения в информационном обеспечении местного самоуправления (социологический анализ). Диссертация ... к.с.н. [Электронный ресурс]. – Хабаровск: Тихоокеанский государственный университет, 2016 (дата публикации 06.10.2020). - URL: http://pnu.edu.ru/media/disser/molyarenko_dessertation.pdf (дата обращения: 27.12.2020)



Схема 1. Взаимосвязь основных понятий¹¹³

С.Ю. Завозкин в работе «Информационное обеспечение интеграции информационных систем на основе системы электронного документооборота» (СЭД), говорит о том, что использование на предприятии СЭД решает такие задачи, как автоматизация работы с документами и бизнес-процессами, обеспечение совместной работы с данными, обеспечение безопасности и надежности хранения информации.¹¹⁴ Это важная часть обеспечения процессов создания ЕМП.

Как мы видим, налицо три разных подхода.

Как отмечает Президент РФ В.В. Путин, интернет-демократия должна быть встроена в общий поток развития институтов прямой референдумной демократии, а проект «электронное правительство» - нацелен на нужды и запросы граждан, максимально полное раскрытие информации о деятельности органов государственной и муниципальной власти. Через электронные технологии необходимо сделать государственный механизм понятным и доступным для общества.¹¹⁵ Таким образом, мы видим весомую

¹¹³Якушенко К.В. Единое информационное пространство: теоретические подходы к содержанию понятия [Электронный ресурс] // Беларусь и мировые экономические процессы: сб. науч. ст. Вып. 11. – Минск, 2014. С.13-20. - URL: <https://elib.bsu.by/bitstream/123456789/134114/1/13-20.pdf> (дата обращения: 27.12.2020)

¹¹⁴См. Завозкин С.Ю. Информационное обеспечение интеграции информационных систем на основе системы электронного документооборота. Автореферат дисс. ... к.т.н. [Электронный ресурс]. – Кемерово: Кемеровский государственный университет, 2007 (дата публикации 9.11.2007). - URL: http://www.ict.nsc.ru/sites/default/files/discouncil/Enlist/Oold_Ref/zavozkin.pdf(дата обращения: 27.12.2020)

¹¹⁵ См. Короткова М.В. Конституционные основы взаимодействия органов публичной власти Российской Федерации и гражданина в информационной сфере. Дисс. ... к.ю.н. [Электронный ресурс]. Саратов:

поддержку идей ЕИП в высших эшелонах власти.

ЕИН является основным и неперенным условием стабильного развития общества и его производительных сил. Целью создания ЕИП является формирование такой среды, в которой достоверная информация станет доступной любому пользователю с учетом единообразных критериев.

Далее мы классифицируем взглядов учёных относительно понятия «информационные ресурсы» на разных уровнях, в том числе в ГИМУ (мы применяем расширительное толкование в рамках группы терминов).

Так, упоминавшаяся О.А. Моляренко в работе «Формальные и неформальные отношения в информационном обеспечении местного самоуправления» пишет лишь о «муниципальной статистике». «Если в 90-ых – начале 2000-ых годов под «муниципальной статистикой» понимались сбор и разработка соответствующих показателей органами местного самоуправления в рамках своих информационных потребностей, то в имеющихся сегодня публикациях под этим термином подразумевается ряд разработанных в соответствии с Федеральным планом статистических работ показателей, представленных в разрезе муниципальных образований».¹¹⁶

С.В. Гринь, рассматривая информационное обеспечение устойчивости развития предпринимательских структур, говорит об «информационном обеспечении управления», что в свою очередь подразумевает предоставление управляющему субъекту информации об управляемом объекте. Информация необходима для реализации функций управления организацией. Стоит отметить, что представленное определение имеет очень широкий смысл. Безусловно, оно является вполне корректным и уместным, но без конкретики в области предпринимательских услуг (которым и посвящена научная работа).¹¹⁷

И.Г. Бойченко были предложены подходы к описанию понятия «электронное взаимодействие федеральных органов исполнительной власти», он пишет: «В целях формирования единообразного подхода под электронным взаимодействием федеральных органов исполнительной власти автором предлагается понимать процесс обмена информацией, выявления мнений граждан и общества, предоставления услуг в

Саратовская государственная юридическая академия, 2014. (дата публикации: 10.04.2014).- URL: <https://elibrary.ru/item.asp?id=22348780> (дата обращения: 27.12.2020)

¹¹⁶ Моляренко О.А. Формальные и неформальные отношения в информационном обеспечении местного самоуправления (социологический анализ). Диссертация ... к.с.н. [Электронный ресурс]. – Хабаровск: Тихоокеанский государственный университет, 2016 (дата публикации 06.10.2020). - URL: http://pnu.edu.ru/media/disser/molyarenko_dessertation.pdf (дата обращения: 27.12.2020)

¹¹⁷ См. Гринь С.В. Информационное обеспечение устойчивости развития предпринимательских структур. Дисс. ... к.э.н. [Электронный ресурс]. – Киров: Вятская государственная сельскохозяйственная академия, 2004. (дата публикации 23.12.2004). - URL: http://library.gpntb.ru/cgi-bin/irbis64r_simple/site/cgiirbis_64.exe?Z21ID=&I21DBN=IBIS&P21DBN=IBIS&S21STN=1&S21REF=&S21FMT=&C21COM=S&S21CNR=20&S21P01=0&S21P02=1&S21P03=A=&S21STR=%D0%93%D1%80%D0%B8%D0%BD%D1%8C%2C%20%D0%A1.%20%D0%92. (дата обращения: 27.12.2020)

электронном виде, а также электронных сервисов в различных социально значимых сферах, основанный на применении информационно-коммуникационных технологий, принципах актуальности и целостности информации, совместимости технологических решений и форматов передачи данных, эволюции информационных систем и иных технологических средств электронного взаимодействия, обеспечения информационной безопасности, включая снижение рисков и угроз кибербезопасности, совершенствования навыков субъектов информационного обмена по эксплуатации систем электронного взаимодействия».¹¹⁸

При сравнении сразу же бросается в глаза социальная направленность этого определения, например по сравнению с «информационной обеспеченности управления». Органы власти любого уровня «направлены» прежде всего на население, его интересы, в то время как первостепенная цель предпринимательской деятельности – получение прибыли.

Е. А. Жбанова отмечает, что ИКТ способствуют формированию новых эффективных средств управления и взаимодействия, помогают повысить качество управления, создавать новые структуры управления, способствуют сокращению сроков согласования решений, позволяют обрабатывать большие объемы информации и при помощи программных средств вырабатывать сложные управленческие решения, повышают открытость и расширяют возможности участия граждан в принятии политических решений, налаживают эффективную обратную связь¹¹⁹. Экономические задачи, которые решают официальные ресурсы органов власти – сокращение затрат на бумагу и печать документов, оплату почты и телефонных переговоров, утрата необходимости в проведении разъяснительных и PR-мероприятий¹²⁰. Те же аргументы приводит и Е. П. Чекулаев¹²¹. Элементы информационного обеспечения обеспечивают сокращение временных затрат на выполнение типовых операций: поиск информации, подготовку справок, отчетов, решений, приём посетителей¹²².

¹¹⁸ Бойченко И.С. Информационно-правовое обеспечение системы электронного взаимодействия федеральных органов исполнительной власти Российской Федерации. Дисс. ... к.ю.н. [Электронный ресурс]. – М.: Институт государства и права Российской академии наук, 2018. (дата публикации: 12.03.2018). - URL: <http://www.dslib.net/soc-systemy/informacionno-pravovoe-obespechenie-sistemy-jelektronnogo-vzaimodejstviya.html> (дата обращения: 27.12.2020)

¹¹⁹ См. Жбанова Е. А. Информационные технологии в политическом процессе функционирования органов государственной власти Забайкальского края. Дисс. ... к.пол.н. [Электронный ресурс]. – Чита: Забайкальский государственный университет, 2011. (дата публикации: 17.03.2011).- URL: <https://www.elibrary.ru/item.asp?id=21484591> (дата обращения: 27.12.2020)

¹²⁰ См. там же.

¹²¹ См. Чекулаев Е. П. Механизм и технологии информационного обеспечения современного российского политического процесса. Автореферат дисс. ...к.пол.н. [Электронный ресурс]. – Нижний Новгород: Нижегородский государственный университет им. И. Н. Лобачевского, 2010. (дата публикации: 21.10.2010).- URL: <https://www.elibrary.ru/item.asp?id=19332058> (дата обращения: 27.12.2020)

¹²² См. Жбанова Е. А. Информационные технологии в политическом процессе функционирования органов государственной власти Забайкальского края. Дисс. ... к.пол.н. [Электронный ресурс]. – Чита:

По мнению В. В. Путина, электронные технологии призваны сделать государственный механизм понятным и доступным для общества, а сайты муниципалитетов и субъектов РФ как элементы информационного обеспечения являются фундаментом, основой т.н. «электронной власти». В качестве задачи В. В. Путин выделяет публичный мониторинг качества медицины, образования, востребованности учреждений культуры¹²³.

Официальные сайты как инструменты ИКТ также выполняют и государственную задачу – реализацию гражданами закрепленного в Конституции РФ права на информацию¹²⁴. Официальные ресурсы обеспечивают открытость органов публичной власти, что помогает бороться с коррупцией и должностными злоупотреблениями. Таким образом, ключевая задача, которую призваны решить официальные ресурсы государственных и муниципальных органов - повышение эффективности механизмов государственного управления и качества предоставления госуслуг.

Информацию до населения в государстве доносят различные источники информации, в том числе средства массовой информации (СМИ). Это важная часть информационного обеспечения в широком смысле. В настоящее время формирование новых общественных отношений требует не только правового регулирования официальных ресурсов, но и его совершенствования.¹²⁵ Цель правового регулирования заключается в обеспечении информационной безопасности и балансе жизненно важных интересов личности, общества и государства. Основным документом, регулирующим деятельность СМИ, является Конституция РФ, которая рассматривает свободу мысли и слова, как неразрывное и единое право мыслить и выражать свои мысли свободно. Регулированием официальных ресурсов занимается Закон РФ «О средствах массовой информации». Деятельность СМИ также регулируют: Гражданский кодекс РФ, Кодекс РФ об административных правонарушениях, Федеральные законы «О государственной тайне», «О рекламе» и др. В России основной импульс к

Забайкальский государственный университет, 2011. (дата публикации: 17.03.2011).- URL: <https://www.elibrary.ru/item.asp?id=21484591> (дата обращения: 27.12.2020)

¹²³ См. Короткова М.В. Конституционные основы взаимодействия органов публичной власти Российской Федерации и гражданина в информационной сфере. Дисс. ... к.ю.н. [Электронный ресурс]. Саратов: Саратовская государственная юридическая академия, 2014. (дата публикации: 10.04.2014).- URL: <https://elibrary.ru/item.asp?id=22348780> (дата обращения: 27.12.2020)

¹²⁴ См. Короткова М.В. Конституционные основы взаимодействия органов публичной власти Российской Федерации и гражданина в информационной сфере. Дисс. ... к.ю.н. [Электронный ресурс]. Саратов: Саратовская государственная юридическая академия, 2014. (дата публикации: 10.04.2014).- URL: <https://elibrary.ru/item.asp?id=22348780> (дата обращения: 27.12.2020)

¹²⁵ См. Гринь С.В. Информационное обеспечение устойчивости развития предпринимательских структур. Дисс. ... к.э.н. [Электронный ресурс]. – Киров: Вятская государственная сельскохозяйственная академия, 2004. (дата публикации 23.12.2004). - URL: http://library.gpntb.ru/cgi-bin/irbis64r_simple/site/cgiirbis_64.exe?Z21ID=&I21DBN=IBIS&P21DBN=IBIS&S21STN=1&S21REF=&S21FMT=&C21COM=S&S21CNR=20&S21P01=0&S21P02=1&S21P03=A&S21STR=%D0%93%D1%80%D0%B8%D0%BD%D1%8C%2C%20%D0%A1.%20%D0%92. (дата обращения: 27.12.2020)

развитию данного законодательства был дан после принятия в 2000 г. ряда важных в институциональном плане актов¹²⁶ и последовавшего позже перехода к цифровой экономике.

В результате проведения исследования работ отечественных ученых по проблематике, вынесенной в заголовок, мы пришли к выводу, что взгляды ученых на проблемы информационного обеспечения и единого информационного пространства в связи с ГИМУ можно типизировать (хотя и с некоторыми оговорками, и при применении ряда упрощений). Следует также дополнительно подчеркнуть особую роль в ГИМУ информационного обеспечения и создания единого информационного пространства; существование двух последних элементов резко повышает эффективность ГИМУ и возможности прямой и обратной связи с гражданами и организациями, что исключительно важно для обеспечения развития страны; цифровизация как таковая существенно ускоряет данные процессы.

Использованные источники:

1. Андреев П.Г. Институциональное развитие правового обеспечения информационной безопасности в российском информационном праве. Дисс. ... к.ю.н. [Электронный ресурс]. – Екатеринбург: Уральская государственная юридическая академия, 2012. (дата публикации 3.05.2012).- URL: <https://www.dissercat.com/content/institutsionalnoe-razvitie-pravovogo-obespecheniya-informatsionnoi-bezopasnosti-v-rossiiskom> (дата обращения: 27.12.2020)
2. Бойченко И.С. Информационно-правовое обеспечение системы электронного взаимодействия федеральных органов исполнительной власти Российской Федерации. Дисс. ... к.ю.н. [Электронный ресурс]. – М.: Институт государства и права Российской академии наук, 2018. (дата публикации 12.03.2018). - URL: <http://www.dslib.net/soc-systemy/informacionno-pravovoe-obespechenie-sistemy-jelektronnogo-vzaimodejstvija.html> (дата обращения: 27.12.2020)
3. Гринь С.В. Информационное обеспечение устойчивости развития предпринимательских структур. Дисс. ... к.э.н. [Электронный ресурс]. – Киров: Вятская государственная сельскохозяйственная академия, 2004. (дата публикации 23.12.2004). - URL: http://library.gpntb.ru/cgi-bin/irbis64r_simple/site/cgiirbis_64.exe?Z21ID=&I21DBN=IBIS&P21DBN=IBIS&S21STN=1&S21REF=&S21FMT=&C21COM=S&S21CNR=20&S21P01=0&S21P02=1&S21P03=A=&S21STR=%D0%93%D1%80%D0%B8%D0%BD%D1%8C%2C%20%D0%A1.%20%D0%92. (дата обращения: 27.12.2020)
4. Жбанова Е. А. Информационные технологии в политическом процессе функционирования органов государственной власти Забайкальского края.

¹²⁶См. Андреев П.Г. Институциональное развитие правового обеспечения информационной безопасности в российском информационном праве. Дисс. ... к.ю.н. [Электронный ресурс]. – Екатеринбург: Уральская государственная юридическая академия, 2012. (дата публикации 3.05.2012).- URL: <https://www.dissercat.com/content/institutsionalnoe-razvitie-pravovogo-obespecheniya-informatsionnoi-bezopasnosti-v-rossiiskom> (дата обращения: 27.12.2020)

- Дисс. ... к.пол.н. [Электронный ресурс]. – Чита: Забайкальский государственный университет, 2011. (дата публикации: 17.03.2011).- URL: <https://www.elibrary.ru/item.asp?id=21484591> (дата обращения: 27.12.2020)
5. Завозкин С.Ю. Информационное обеспечение интеграции информационных систем на основе системы электронного документооборота. Автореферат дисс. ... к.т.н. [Электронный ресурс]. – Кемерово: Кемеровский государственный университет, 2007 (дата публикации 9.11.2007). - URL: http://www.ict.nsc.ru/sites/default/files/discouncil/Enlist/Oold_Ref/zavozkin.pdf (дата обращения: 27.12.2020)
6. Короткова М.В. Конституционные основы взаимодействия органов публичной власти Российской Федерации и гражданина в информационной сфере. Дисс. ... к.ю.н. [Электронный ресурс]. Саратов: Саратовская государственная юридическая академия, 2014. (дата публикации: 10.04.2014).- URL: <https://elibrary.ru/item.asp?id=22348780> (дата обращения: 27.12.2020)
7. Моляренко О.А. Формальные и неформальные отношения в информационном обеспечении местного самоуправления (социологический анализ). Диссертация ... к.с.н. [Электронный ресурс]. – Хабаровск: Тихоокеанский государственный университет, 2016 (дата публикации 06.10.2020). - URL: http://pnu.edu.ru/media/disser/molyarenko_dessertation.pdf (дата обращения: 27.12.2020)
8. Чекулаев Е. П. Механизм и технологии информационного обеспечения современного российского политического процесса. Автореферат дисс. ...к.пол.н. [Электронный ресурс]. – Нижний Новгород: Нижегородский государственный университет им. И. Н. Лобачевского, 2010. (дата публикации: 21.10.2010).- URL: <https://www.elibrary.ru/item.asp?id=19332058> (дата обращения: 27.12.2020)
9. Якушенко К.В. Единое информационное пространство: теоретические подходы к содержанию понятия [Электронный ресурс] // Беларусь и мировые экономические процессы: сб. науч. ст. Вып. 11. – Минск, 2014. С.13-20. - URL: <https://elib.bsu.by/bitstream/123456789/134114/1/13-20.pdf> (дата обращения: 27.12.2020)

ТЕНДЕНЦИИ СОЦИАЛЬНО-ЭКОНОМИЧЕСКОГО РОСТА РАЗВИТИЯ СТРАНЫ

Аннотация. Эксперты в сфере экономики утверждают, что ранее введенные санкции и ответные меры России, постепенно повлияют, а как следствие приведут к уменьшению рынка сбыта отечественной продукции за рубеж. Показатели капиталовложений по различным направлениям в экономику нашей страны станут ниже.

Ключевые слова: экономика страны, экономические санкции, последствия применения санкций.

*Konkova O.V.
Donskoy State Agricultural University*

TRENDS IN SOCIO-ECONOMIC GROWTH OF THE COUNTRY'S DEVELOPMENT

Annotation. Experts in the field of Economics argue that the previously imposed sanctions and Russia's retaliatory measures will gradually affect, and as a result will lead to a decrease in the market for domestic products abroad. Indicators of investment in various areas of our country's economy will be lower.

Keywords: national economy, economic sanctions, consequences of sanctions.

Системное решение задач реформирования в сфере экономики заключается в ее переводе от экспортно-сырьевого к инновационному социально ориентированному типу развития. Политическим решением о таком переводе явилась Стратегия социально-экономического развития России до 2025 года. Реализация этой стратегии основывается на Концепции социально-экономического развития страны, утвержденной распоряжением правительства № 1662-р от 17 ноября 2008 г.

Цель концепции - определение путей и способов обеспечения в долгосрочной перспективе (2008 - 2025годы) устойчивого повышения благосостояния российских граждан, национальной безопасности, динамичного развития экономики, укрепления позиций России в мировом сообществе.

В соответствии с этой целью в концепции сформулированы:

- - основные направления долгосрочного социально-экономического развития страны с учетом вызовов предстоящего периода;

- - стратегия достижения поставленных целей, включая способы, направления и этапы;
- - формы и механизмы стратегического партнерства государства, бизнеса и общества;
- - цели, целевые индикаторы, приоритеты и основные задачи долгосрочной государственной политики в социальной сфере, в сфере науки и технологий, а также структурных преобразований в экономике;
- - цели и приоритеты внешнеэкономической политики;
- - параметры пространственного развития российской экономики, цели и задачи территориального развития.

В рамках оценки совокупного многопериодного эффекта на экономику мы отталкиваемся от сценария, как, на наш взгляд, наиболее соответствующего заявленной цели рационализации потребления энергоресурсов. Если не проводить качественных институциональных изменений в отрасли, то, по сути, рост цен на нефть и нефтепродукты в конечном итоге через неэффективность и неспособность к модернизации отечественной нефтепереработки переложится на потребителей. Такие неэффективные предприятия должны, с точки зрения общественного благосостояния, уйти с внутреннего рынка, а их продукция должна быть замещена увеличением выпуска на модернизированных российских НПЗ и иностранными компаниями на конкурентных основах. Таким образом, пороговое значение безболезненного проведения реформ составляет около 12 лет. Стратегической целью в экономике является достижение уровня экономического и социального развития, соответствующего статусу России как ведущей мировой державы XXI века, занимающей передовые позиции в глобальной экономической конкуренции и надежно обеспечивающей национальную безопасность и реализацию конституционных прав граждан.

Достижение этой цели означает формирование качественно нового образа будущей России к концу следующего десятилетия. Основными элементами такого образа будут являться:

- - высокие стандарты благосостояния человека;
- - социальное благополучие и согласие;
- - экономика лидерства и инноваций;
- - сбалансированное пространственное развитие;
- - экономика, конкурентоспособная на мировом уровне;
- - институты экономической свободы и справедливости;
- - безопасность граждан и общества.

Для обеспечения инновационного развития должна быть сформирована соответствующая институциональная среда (т.е. созданы определенные материальные и духовные предпосылки). Ведущими направлениями формирования среды инновационного развития являются поддержка инновационного бизнеса и расширение спроса на инновации в экономике. При успешном решении задачи создания инновационной

экономики доля экономики знаний и высокотехнологичного сектора в валовом внутреннем продукте должна составлять не менее 17-20 процентов. В качестве стратегических векторов экономической модернизации страны на ближайшие годы определены следующие. Масштабные перемены в экономике будут основой политического развития страны. В этой связи развитие политической системы и гражданского общества в России тесно связано с темпами реформирования экономической сферы. Кроме того, эксперты указывают на торговые напряженности — между США и Китаем развернулась настоящая война. Глава ЦБ заявляла, что торговые конфликты могут негативно повлиять и на российскую экономику. «Эти изменения, конечно, неблагоприятны, это влияет на торговые переговоры. Риск торговых международных войн влияет на восприятие инвесторами экономических перспектив, существует риск снижения темпов глобальной экономики. Это может повлиять на российскую экономику через цены на нефть, спрос на нефть и другие товары, через финансовые рынки. Мы будем учитывать этот факт, как один из факторов, влияющих на наше прогнозирование и решения. Напомним, в прошлом году рост экономики России составил 2,3%, по оценке Росстата, и 2% — согласно оценке Минэкономразвития. Между тем первый показатель признавали «совершенно неожиданным» в Центре макроэкономического анализа и краткосрочного прогнозирования (ЦМАКП). " «Уже прошло 9 месяцев этого года, и те ожидания, которые были в начале года, связанные с началом реализации национальных проектов как драйвера экономики, не сбываются. На реализацию национальных проектов по 12 направлениям с 2019 по 2024 год российские власти планируют потратить более 25,7 триллионов рублей. Расходование бюджетных средств по ним остается пока низким — меньше половины. По последним данным Минфина России, кассовое исполнение нацпроектов на 13 сентября составило всего лишь 47%. Таким образом, существенная часть средств, которые должны были быть направлены на финансирование нацпроектов в этом году, видимо, использованы не будут. Кроме того, одним из факторов, влияющих на понижение прогноза, эксперт указывает продолжение жесткой бюджетной политики. У бюджета значительный профицит — но средства выделяются в меньших масштабах, чем должно было быть, с точки зрения госфинансирования — это является тормозом для экономики. Доходы падают, розничная торговля тормозит. А в этом году рост инвестиций всего на 0,5% с учетом полного круга компаний и неформальной деятельности, при этом если смотреть среди крупных компаний, то в первом полугодии они сократились на 1,1%, продолжает эксперт. То есть одной опоры из трех уже нет. С экспортом из-за торговых войн уже тоже сложнее — из источников роста он ушел, добавляет эксперт. Таким образом, экономике России остается держаться на одной ножке — конечное потребление домохозяйств. Однако и с этим есть проблемы.

Основная развилка бюджетной политики находится между продолжением эксплуатации благоприятных внешнеэкономических условий в отсутствие серьезных экономико-политических реформ и созданием макроэкономических и институциональных условий для формирования новой модели роста. В последнем случае предполагается не механическое балансирование бюджета и сокращение расходов до уровня структурных доходов, но проведение блока реформ — пенсионной, военной, налоговой, реформы бюджетного сектора, образования, здравоохранения, науки, системы социальной поддержки населения, управления госсобственностью, естественных монополий и т. д. В рамках этой развилки можно выделить три сценария. В условиях первого сценария, инерционного, предполагающего отказ от реформ бюджетного сектора и связанных с ним институтов и сегментов рынка, рост бюджетных обязательств приводит к возникновению устойчивого дефицита бюджетной системы. Он достигает 7–8% ВВП даже при достаточно комфортном уровне цен на нефть (не ниже 90 долл. за баррель в ценах 2010 г.). Сбалансированность бюджета в таком сценарии достигается при ценах на нефть устойчиво не ниже 155–160 долл. за баррель в ценах 2010 г. Финансирование указанного дефицита (возникающего в условиях консервативной оценки вероятного уровня цен на нефть) за счет государственных заимствований означает рост объема государственного долга России к 2025 г. до 70–80% ВВП. Это представляется недопустимым в условиях ресурсной экономики, где существует риск снижения цен на нефть и резкой переоценки уровня рисков вложений в российские активы инвесторами в этом случае. Второй сценарий, компромиссный, обеспечивает сочетание дополнительных бюджетных расходов по приоритетным направлениям (на развитие инфраструктуры и человеческого капитала) с постепенным повышением сбалансированности бюджетной системы. При этом действуют бюджетные правила, регулирующие использование бюджетных доходов в рамках конъюнктурного «цикла» сырьевых цен. Объем государственного долга в этом сценарии к 2025 г. не превосходит 25% ВВП, что позволяет профинансировать приоритетные направления расходной части бюджета и обеспечить финансовый сектор экономики и денежные власти безрисковыми активами с базовой процентной ставкой. Третий сценарий, жесткий, исходит из приоритетности задачи достижения макроэкономической сбалансированности. Это предполагает принятие более жестких бюджетных правил и, соответственно, меньшее увеличение расходов по приоритетным направлениям. В этом случае размеры государственного долга оказываются существенно меньшими, чем во втором сценарии. Выбор между вторым и третьим сценариями представляет собой важную развилку, требующую политического решения. Новая модель роста предполагает ориентацию на постиндустриальную

экономику — экономику завтрашнего дня. В ее основе лежат сервисные отрасли, стимулирующие развитие человеческого капитала: образование, медицина, информационные технологии, медиа, дизайн, «экономика впечатлений» и т. д. И в развитых, и в развивающихся странах возникает креативный класс — люди творческого труда, создающие инновации уже в ходе своей обычной работы. Именно они будут обеспечивать решающие конкурентные преимущества в соревновании экономик XXI в. Как показывает новейшая экономическая история, порождение инноваций креативным классом происходит относительно независимо от институциональной среды, в рамках организаций и сетей самого разного типа (вместе с тем капитализация этих инноваций требует определенных институциональных предпосылок). Это предопределяет необходимость качественно иного подхода ко всем отраслям, связанным с развитием человеческого капитала.

Использованные источники:

1. Кудрин, А. Новая модель роста для российской экономики / А. Кудрин, Е. Гуревич // Вопросы экономики. – 2018. - № 12. – С. 4-37
2. Семахин Е.А., Лаврентьева Л.В., Плакса Е.Н. Проблемы и перспективы развития российской экономики в условиях санкций // Международный журнал прикладных и фундаментальных исследований. – 2016. – № 11-6. – С.
- 3 Голубев А.В. Тенденции аграрной динамики России.- М.: РГАУ-МСХА им. К.А. Тимирязева. -2011.- 240с.
- 4 Делавинья С. Психология и экономика: результаты эмпирических исследований, часть 2.Общественно ориентированные предприятия и нестандартные убеждения //Вопросы экономики.-2011.-№5. – С.56.

ИНТЕГРИРОВАННЫЙ ПОДХОД И МОДЕЛИРОВАНИЕ ФАЗ ЦИКЛИЧЕСКИХ ПРОЦЕССОВ В СЕЛЬСКОМ ХОЗЯЙСТВЕ РОССИИ

Аннотация: В статье рассматриваются вопросы моделирование циклических процессов в сельском хозяйстве России которые должны базироваться на интегрированном переходе, включающим сильные стороны сигнального и моделирующего методов. Факторы вызывающие кризис экономики России изменение правил экономической деятельности внутри страны в соответствии с взятыми обязательствами в рамках соглашения с ВТО и таможенным союзом.

Ключевые слова: кризисные явления, финансовые потоки, кризис, динамика, цикличность.

*Konkova O.V.
Donskoy State Agricultural University*

INTEGRATED APPROACH AND MODELING OF PHASES OF CYCLICAL PROCESSES IN RUSSIAN AGRICULTURE

Abstract: the article deals with the modeling of cyclical processes in agriculture in Russia, which should be based on an integrated transition that includes the strengths of the signal and modeling methods. Factors causing the crisis of the Russian economy changes in the rules of economic activity within the country in accordance with the obligations under the agreement with the WTO and the customs Union.

Keywords: crisis phenomena, financial flows, crisis, dynamics, cyclicity.

В XIX веке неравномерность экономической динамики приводила к экономическим кризисам и в Российской Империи. Из экономической истории нашей страны известны экономические кризисы 1808-1815гг., 1833-1843гг., 1853-1857гг., 1877-1880гг., 1899-1903гг. По мере развития внешней торговли, практики внешних государственных и частных заимствований кризисы перестали ограничиваться национальными границами отдельных стран, а постепенно включать в свою орбиту и страны, с которыми кризисные экономики поддерживали мировые торгово-финансовые отношения.

Мировой финансово-экономический кризис 2008-2009 годов показал, что используемый экономической наукой инструментарий не всегда

позволяет органам государственного управления своевременно выявить кризисные ситуации в экономике и отреагировать на них пакетом мер государственного регулирования.

По утверждению ряда российских ученых и экспертов кризисные явления в российской экономике были вызваны финансовыми и торговыми потоками, снижением качества функционирования социально-экономических институтов, «перегревом» экономики, экономической цикличностью.

Если говорить о финансовых потоках то можно отметить разнонаправленную динамику стоимости денег внутри страны и на мировых финансовых рынках. Это привело к резкому росту внешнего корпоративного долга- до 454,8 млрд. долларов (на 1 июля 2008 года).

Торговые потоки определяются высокой зависимостью как бюджетной системы, так и всей финансовой системы государства от сырьевых экспортных доходов. В последние годы уровень этих доходов в бюджете РФ составлял 40-45 % или 8-9,7 % ВВП.

Макроэкономические прогнозы министерства финансов России и Минэконом развития страны позволяет делать вывод о том, что вышеназванные факторы и в среднесрочной перспективе будут создавать риски функционирования экономики и ведения экономической деятельности. Так например министерство финансов в период 2012-2014 годов планирует увеличить государственный внешний долг с 34,81 млрд. долларов (апрель 2012) до 69 млрд. долларов. Корпоративный внешний долг уже по итогам 2011 года превысил докризисный уровень на 9,93 % и составляет 500 млрд. долларов.

Финансовые риски будут сохраняться на фоне прогнозируемых торговых потоков (табл. 1.13)

Таблица 1.13 – Некоторые параметры федерального бюджета РФ

Показатели	Ед.измерения	годы			2014г. (+,-) к 2012г.
		2012	2013	2014	
Доля сырьевых доходов в доходной части федерального бюджета	%	44,9	45,5	44,5	-0,4
Доля сырьевых доходов в ВВП	%	9,69	9,01	8,67	-1,02
Прогноз внешних государственных заимствований (внешний гос. долг)	млрд.долл.	48	59,4	69,0	+20,6

Источник: Составлена и рассчитана автором по данным Минфина России.

К отмеченным факторам, вызвавшим кризис экономики России следует добавить изменения правил экономической деятельности внутри страны в соответствии с взятыми обязательствами в рамках соглашения с ВТО и таможенным союзом. Рассматривая фактор снижения качества институтов, как нам представляется, целесообразно говорить не о качественных оценках, а о недостаточном уровне развития институтов, и прежде всего институтов обеспечивающих коммуникацию горизонтальных отношений (кооперация, саморегулирующие организации, общественные палаты бизнеса). Например, предкризисный 2007 год российская кооперативная система имела крайне низкий уровень своего развития, который продолжает сохраняться и в настоящее время.

В докризисный период российская экономика испытывала перегрев, который характеризовался:

- ростом объемов кредитования (с 16,8 % до 37,8 % за 2003-2007 гг.);
- высокой инфляцией (15 % и более в год);
- определяющим ростом внутреннего спроса в сравнении с динамикой внутреннего производства;
- рост фондовых индексов;
- рост цен на недвижимость.

Динамика развития российской экономики в пост социалистический период характеризуется сменой равновесной и неравновесной траекторией изменения показателей, характеризующих результаты экономической деятельности. Анализ динамики ВВП страны позволяет сделать вывод о том, что в ее экономике сформировались четырехлетние циклы понижения и повышения показателей дающих представления о результатах хозяйственной деятельности (рис. 1.7).



Рисунок 1.7 – Динамика ВВП России (в сопоставимых ценах; в % к предыдущему году). (Источник: Составлен автором по данным Росстата)

Если мы обратимся к данным рисунка 1.7., то можем говорить о том, что за период с 1995 года по 2008 год в экономике России отмечается четыре цикла.

Исследователи выделяют и такие каналы распространения кризиса, как информационный канал и ухудшение макроэкономических показателей ведущих экономик мира.

Информационный канал распространения кризиса связан с изменениями ожиданий инвесторов, характера их реакции на ухудшение экономических показателей развития в стране, в экономику которой вложены портфельные инвестиции.

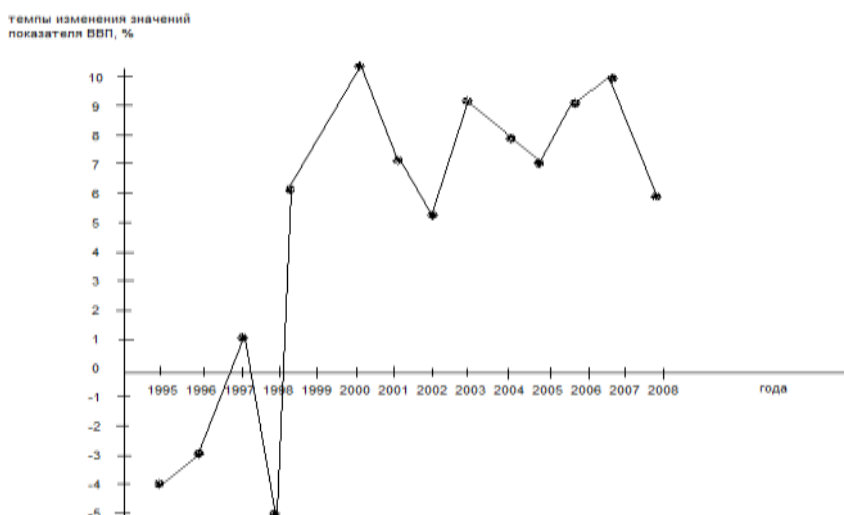
Кризис, возникнув в одной стране, может распространяться между странами при изменении в худшую сторону макроэкономических параметров ведущих экономических держав мира. Хорошо известны факты о том, с каким интересом игроки на финансовых и торговых рынках ожидают публикации отчетов Федеральной резервной системы США или прогнозов и балансов продуктов Минсельхоза США.

Рассмотренный выше методический подход может быть отнесен к сигнальному методу. В рамках отраслевой проекции может быть использован и метод модернизирования экономической цикличности. При этом в качестве инструментария предлагается использовать для прогнозных расчетов метод межотраслевого баланса, линейные и экспоненциальные функции, гармонические и логические функции. Представляется, что моделирование циклических процессов в сельском хозяйстве России должно базироваться на интегрированном переходе, включающим сильные стороны сигнального и моделирующего методов. В процессе прогнозирования на первом этапе на основе сигнального метода определяется фаза экономической цикличности, на втором этапе выполняется моделирование циклических процессов в российском сельском хозяйстве.

Использованные источники:

1 Велиева И.С. Поиск оптимальной стратегии отказа от экстренных мер поддержки российского банковского сектора. // Деньги и кредит. - 2010. - №5. С.58.

2 Голубев А.В. Тенденции аграрной динамики России. - М.: РГАУ-МСХА им. К.А. Тимирязева. - 2011. - 240с.

3 Делавинья С. Психология и экономика: результаты эмпирических исследований, часть 2. Общественно ориентированные предприятия и нестандартные убеждения // Вопросы экономики. - 2011. - №5. - С.56.

4 Кузнецов, В.В., Тарасов, А.Н., Дунаев, В.Л. Прогнозирование производства сельскохозяйственной продукции, сырья, продовольствия: методика, сценарии, инструменты. // - Ростов н/Д: ГНУ ВНИИЭиН Россельхозакадемии, 2011. - 179 с.

5 Савицкая Г.В. Экономический анализ: Учеб. / Г.В. Савицкая.- 10-е изд., испр.- М.: Новое знание, 2004.- 640с., с.617

6 Моисеенко Ж.Н. и др. Проблемы развития сельского хозяйства в условиях рынка: внутрхозяйственный аспект. //монография, п. Персиановский 2008г. 113стр.

7 Тарасов А.Н., Конькова О.В., и др. Цикличность в аграрном секторе экономики и методы ее диагностики.//монография Ростов- на- Дону: ГНУВНИИЭиН Россельхозакадемии, 2013.- 49 с.

*Коротченкова А.В.
студент магистратуры
Алексеева И.В., д.э.н.
доцент*

ИСПОЛЬЗОВАНИЕ ИНСТРУМЕНТОВ ЦИФРОВОЙ ЭКОНОМИКИ ДЛЯ ФОРМИРОВАНИЯ ФИНАНСОВОЙ ОТЧЕТНОСТИ КОММЕРЧЕСКИХ ОРГАНИЗАЦИЙ

Аннотация: Статья рассматривает проблемные стороны в формировании отчётов о финансовых результатах, бухгалтерской отчётности. Анализирует подходы различных исследователей экономических явлений к повышению эффективности учёта и контроля. В статье определены предпосылки к реформированию экономической отчётности по западному образцу.

Ключевые слова: учёт, теория управления, цифровая экономика, бухгалтерский учёт, отчётность, система бухгалтерского учёта

*Korotchenkova A.V.
undergraduate
Alekseeva I.V., Phd in economics
docent*

USING DIGITAL ECONOMY TOOLS TO GENERATE FINANCIAL STATEMENTS FOR COMMERCIAL ORGANIZATIONS

Abstract: The article examines the problematic sides in the formation of reports on financial results, accounting statements. Analyzes the approaches of various researchers of economic phenomena to improve the efficiency of accounting and control. The article identifies the preconditions for reforming economic reporting according to the Western model and summarizes the positive and negative impact of innovation.

Keywords: accounting, management theory, digital economy, accounting, reporting, accounting system

Одним из наиболее востребованных направлений в экономической среде является развитие цифровой экономики. Потому как цифровизация охватывает всю систему информационного обеспечения социально-экономических процессов. Важные позиции занимает бухгалтерский учёт с его функционалом сбора, обработки и предоставления экономической информации о деятельности хозяйствующих субъектов. Учёт в цифровой экономике приобретает все более важное значение. Изменения

методологических и концептуальных основ бухгалтерского учёта происходят вследствие влияния технологических возможностей цифровизации.

Эффективность финансово-хозяйственной деятельностью субъектов зависит от проведения учёта и контроля. По мнению профессора В. И. Бариленко условием для создания стабильного развития экономических субъектов является бизнес-анализ. Стоит отметить, что наиболее проблемным участком в принятии управленческих решений можно принять недостаток инструмента информационного сопровождения принятия в виде невозможности самостоятельного выявления проблемы.

Идея концепции единого интеграционного пространства в экономической деятельности будет иметь ряд сложностей, т.к. формирование особой экономической зоны, с точки зрения В. И. Бариленко, с отсутствием пространственной локализации трудна в реализации [2].

Профессорами И. А. Слободняком и Т. Г. Арбатская так же выдвинули гипотезу о реализации единой теории бухгалтерского учёта [7], но воздержались от уточнения параметров единения.

Р.П. Булыга в рамках конференции «Цифровое будущее инновационной экономики России» обратил внимание на акцентировании внимания к процессам учёта и контроля экономических явлений, определяющие экономику в качестве цифровой, что значительно упрощает все стадии проведения сквозного характера учёта (финансового, управленческого, налогового), контроля (техничко-технологического, качества продукции и работ, производственного, финансового, внутреннего и внешнего) и анализа (Федеральная служба аккредитации на уровне подготовки производства, текущего, что ведёт их объединению и усовершенствованию) [3].

Специфические особенности субъектов будут влиять на создание учёта сквозного характера. Неизбежность реформ в информационном обеспечении управленческих решений, так же отметила аудитор Е. Анненкова, что подтверждается изменением регламента аудита бухгалтерской (финансовой) отчётности [1]. С 2018 года введена в действие МСА и применяются документы, принятые Международной федерацией бухгалтеров [2].

Альтернативные инновации в области учёта анализа и контроля были предложены В. С. Плотниковым, О. В. Плотниковой, которые выдвинули предположение о замещении принципов бухгалтерского учёта некими «качественными характеристиками информации Интегрированного отчёта» [5]. По утверждению авторов разработки «модели бизнес-учёта и интегрированной отчётности ориентированы на отражение результатов процессов создания стоимости во времени при трансформации отдельных видов капиталов организации».

Наиболее проблемными аспектами подготовки отчётов о финансовых результатах выступают отсутствие обмена оперативной информацией. Низкая скорость обработки информации, отсутствие обеспечения организаций большим количеством необходимых данных, невозможность получения большего объёма информации не даёт возможность организациям детализировать информации, финансовых отчётов определяет направление развития «цифровой экономики». Прорывы в сфере компьютерной техники и средств коммуникации, информатизации в целом, расширили возможности при подготовке финансовой отчётности.

К современным широко применяемым инновациям можно отнести: применение внутри организации компьютерных сетей, локализованных для обмена информацией, посредством Интернета, получение и передача информации путём применения переходов по сайтам и облачных хранилищ информации, движение информационных потоков по электронной почте, так же в качестве инструмента ускорения обмена информацией можно считать использование социальных сетей. Повышению производительности в обработке информации и обеспечение организаций большим количеством необходимых данных возможно при использовании вышеперечисленных методов.

Организация, оперируя большими объёмами информации, расширяет возможности в её детализации, фигурирующей в финансовой отчётности. Манипуляция большими объёмами информации ставит проблему качества её обработки. Программные средства позволяющие работать с информационными массивами позволят решить эту проблему.

Создание финансовых отчётов и проведение бухгалтерского учёта, учёта входных финансовых показателей автоматизировалось за счёт применения инструментов «цифровой экономики». Одновременно с реформированием систем бухгалтерского учёта происходит обновление и совершенствование таких программных продуктов с учётом колебания экономической ситуации для организаций.

Россия с этапа вхождения в рыночную экономику встала на путь реформирования и инноваций бухгалтерских стандартов, отчётов и постоянно находится в режиме совершенствования. Данный факт объясняется стремление соответствия международным стандартам в экономической сфере.

Отметим ключевые факторы в разрешении проблем обновления методологии учёта, контроля и аналитики в возможной перспективе и развития понятийного аппарата.

Во-первых, предпосылкой к увеличению информационности в отчётах стал актуальный в современном мире переход к «информационному обществу», масштабное применение понятий «гармонизация», «интеграция», «консолидация», «конвергенция» и п.[4] Бухгалтерская

(финансовая) отчётность в её традиционном понимании подверглась критике.

Отказу от отечественных стандартов учёта, анализа и контроля в угоду зарубежным стандартам стал следствием осознания разработчиками всех сложностей расширения границ отчётной информации. Сложно оценить такое решение положительно, т.к. нереформированными в России остаются сами основополагающие стандарты финансово-хозяйственной деятельности, в экономике отсутствует иерархия: определённые отрасли развиваются достаточно интенсивно, а другие остаются на рубеже «каменного» века (строительство, жилищно-коммунальное хозяйство, транспортно-складское хозяйство) [7,8].

Во-вторых, при следовании мировым тенденциям развития экономического знания стоит с большим скептицизмом относиться к новым терминам, и к новым концепциям информационного обеспечения управления финансово-хозяйственной деятельностью. П. Самуэльсона, лауреат нобелевской премии, предостерег экономистов о том, что «в социальных науках нужно особенно остерегаться «тирании слов». «Мир весьма сложен и без того, чтобы в него привносились новая путаница и неясности, связанные с тем, что, во-первых, два различных слова по незнанию используются для обозначения одного и того же предмета, и, во-вторых, одно и то же слово применяется к двум совершенно различным явлениям» [6].

В-третьих, современная наука и практика информационного обеспечения оперирует большинством терминов, которые определены, но недостаточно чётко или вызывают обсуждения у пользователей в трактовке, в официальных документах, например, в российском и международном вариантах. Концептуальные основы, оставаясь вспомогательным документом, используются составителями финансовой отчётности в качестве методического руководства по применению МСФО в отношении тех вопросов учёта, которые не освещены ещё в текстах конкретных МСФО. Кроме того, Концептуальные основы полезны пользователям финансовой отчётности в их интерпретации показателей финансовой отчётности, составленной в соответствии с МСФО, а также в понимании сути использованных терминов [9].

В-четвёртых, нет «цифровой экономики» самой по себе. Есть сегменты экономики которой больше пронизаны автоматизацией, некоторые – меньше, т.е. отсутствует единство, как таковое.

Автоматизация и цифровизация формирования отчёта о финансовых результатах совершенствует практику ведения бухгалтерского учёта и возможна благодаря расширению информационного потенциала существующего экономического пространства. Информационные технологии служат толчком для существенных модификаций, как в методологии, так и в прикладном направлении науки о бухгалтерском учёте.

Новые потребности трансформируют бухгалтерский учёт и выступают необходимым этапом его развития. Видоизменения и инновации учёта позволят не потерять его актуальность в эпоху всеобщей цифровизации.

Использованные источники:

1. Анненкова, Е. Аудит бухотчетности за 2017 год: что изменилось // [Электронный ресурс]. – Режим доступа: <https://buh.ru/articles/documents/65376/> (дата обращения: 12.11.20).
2. Бариленко, В. И. Бизнес-анализ как инструмент обеспечения устойчивого развития хозяйствующих субъектов // Учет, анализ, аудит. – 2014. – 32 с
3. Булыга, Р. П. Классификация и стандартизация финансового контроля и аудита в Российской Федерации. Учет. Анализ. Аудит. – 2017- 18 с..
4. Введение в «Цифровую» экономику / А. В. Кешелава, В. Г. Буданов, В. Ю. Румянцев и др.; под общ. ред. А. В. Кешелава [Электронный ресурс]. – Режим доступа: <http://lexandbusiness.ru> (Дата обращения: 11.11.2020).
5. Международная научно-практическая конференция «Цифровое будущее инновационной экономики России» Конференция. Даты проведения: 6 декабря 2017. Место проведения: РЭУ имени Г. В. Плеханова, Россия. – Режим доступа: <https://istina.msu.ru/conferences/88967577/> (Дата обращения: 11.11.20)
6. Самуэльсон, П. Экономика: вводный анализ. Т. 1. – М.: Алгон, 1997. – 333 с.
7. Слободняк, И. А. Единая теория бухгалтерского учета как необходимое и достаточное условие формирования единого учетного пространства / И. А. Слободняк, Т. Г. Арбатская // Учет. Анализ. Аудит. – 2015. – No 3. – С. 43-53.
8. Управление инновационным развитием высокотехнологичных корпораций России: монография / И. В. Никитенко, Т. М. Рогуленко, С. В. Пономарева. – М.: Издательство «Русайнс», 2015. – 200 с.
9. Цифровая экономика. Развитие цифровой экономики в России / Представительство Всемирного банка в России [Электронный ресурс]. – Режим доступа: <http://www.vsemirnyjbank.org/ru/events/2016/12/20> (Дата обращения: 11.11.2020).

*Кочанова А.А.
студент*

*Российская академия народного хозяйства и государственной службы
при Президенте Российской Федерации
Санкт-Петербург*

KPI КАК СОВРЕМЕННЫЙ ИНСТРУМЕНТ МОТИВАЦИИ ПЕРСОНАЛА ПРЕДПРИЯТИЯ

Аннотация: В качестве одного из важнейших ресурсов любого предприятия в современных условиях выступает персонал. В связи с чем, деятельность руководства предприятий должна быть направлена на то, чтобы повысить эффективность использования возможностей сотрудников, что, как следствие, требует разработки мероприятий по повышению заинтересованности персонала в достижении поставленных перед организацией целей. Последнее обстоятельство требует использования ключевой функции управления – мотивации. Повышение мотивационной составляющей в деятельности сотрудников предприятия требует внедрения индивидуального подхода к разработке системы стимулирования, которое принято подразделять на материальное и нематериальное. Одним из современных инструментов мотивации и стимулирования персонала выступает управление по целям и разработка системы KPI.

Ключевые слова: мотивация, стимулирование персонала, методы мотивации, управление по целям, система KPI

*Kochanova A.A.
student
Russian Presidential Academy of National Economy and Public
Administration
Saint-Petersburg*

KPI AS A MODERN TOOL FOR MOTIVATING ENTERPRISE PERSONNEL

Abstract: Personnel is one of the most important resources of any enterprise in modern conditions. In this regard, the activities of the management of enterprises should be aimed at improving the efficiency of using the capabilities of employees, which, as a result, requires the development of measures to increase the interest of staff in achieving the goals set for the organization. The latter circumstance requires the use of a key management function – motivation. Increasing the motivational component in the activities of employees of the

enterprise requires the introduction of an individual approach to the development of a system of incentives, which is usually divided into material and non-material. One of the modern tools for motivating and stimulating staff is goal management and the development of a KPI system.

Key words: motivation, staff incentives, methods of motivation, management by objectives, KPI system

Современным методом управления предприятием выступает управление по целям. Фактически при использовании метода управления по целям в организации разрабатывается видение будущего (vision), формулируются стратегические и тактические цели предприятия, определяются служебные функции сотрудников, разрабатываются ключевые показатели деятельности, внедряется оплата по результатам работы и другие инструменты, заточенные на достижение целей компании.

Когда стратегические цели компании сформулированы, необходимо закрепить ответственность руководителей и сотрудников за их достижение. Другими словами, цели надо как-то «спустить вниз» или каскадировать по административной структуре, и при этом сохранить баланс целей на разных уровнях организации. Это достигается путем применения системы KPI.

На практике система KPI позволяет оценить разнообразные результаты работы, как предприятия в целом, так и отдельных его подразделений, а также сотрудников. Следовательно, данный инструмент мотивации может быть рассмотрен как некоторая функция, которая отражает изменения в результатах работы предприятия в зависимости от качества и количества используемых ресурсов. Значения KPI позволяют оценить, какова степень достижения целей предприятия.

Система KPI «затачивает» организацию на достижение результата и более эффективную деятельность и принуждает каждого работника к более производительному труду.

Для того чтобы сотрудники были заинтересованы в достижении системы KPI, необходимым представляется разработка системы стимулирования на базе ключевых показателей эффективности. Ее разработка должна включать в себя ряд этапов, которые представлены на рисунке 1.

Для системы KPI характерны следующие особенности, которые учитываются при ее разработке:

1. Адресный подход – т.е. для каждого подразделения и сотрудника определяется свой круг показателей, которые зависят от функциональных обязанностей.

2. Учет вектора движения, т.е. показатели должны быть привязаны к особенностям бизнес-процессов и поставленным перед предприятием целям.

3. Показатели должны быть достижимы.
4. Показатели могут быть подвержены корректировке в случае необходимости.
5. Можно количественно оценить, как изменится стоимость бизнеса при достижении целевых показателей.



Рис. 1. Этапы построения и внедрения системы KPI

6. Количество показателей должно быть минимальным, должны учитываться только те, которые характеризуются высокой приоритетностью.
7. Показатели должны легко восприниматься сотрудниками предприятия.
8. Должны выбираться показатели, которые выступают в качестве базы для оценки наиболее важным аспектов деятельности предприятия.

Одной из сильных стороны системы КРІ является то, что можно учесть, как отраслевую специфику деятельности компании, так и функциональные обязанности конкретных работников. В связи с чем, данная система стимулирования нашла широкое применение в сбытовых структурах компаний.

Система КРІ в сбытовой структуре компании в соответствии с бизнес-процессами, которые выделены в сегменте «Каналы сбыта», «Целевые группы клиентов», «Взаимодействие с клиентами», «Ценностное предложение» и «Структура доходов».

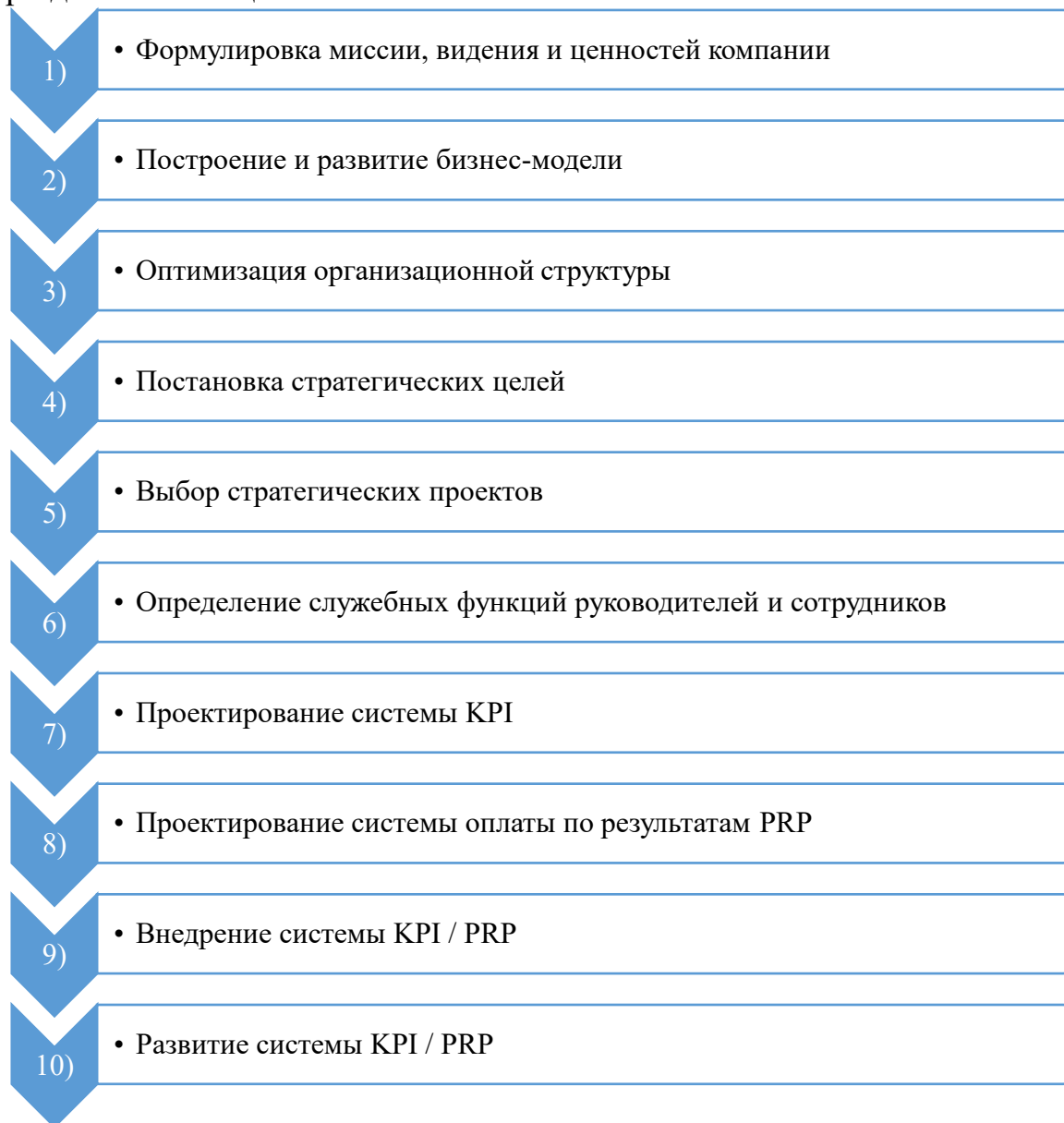
Приведем примеры. Если блок «Каналы сбыта» включает в себя такой элемент, как «Прямые продажи», то поддержка данного бизнес-процесса осуществляется за счет следующих элементов «Обработка заказов, поступивших от покупателей», «Развитие клиентской базы», «Заключение договоров с клиентами».

В том случае, если блок «Ценностное предложение» включает в себя «Доставку точно в срок», то на предприятии необходимо внедрение таких бизнес-процессов, как «Планирование доставки товаров покупателю», «Формирование комплектации заказа на складе», «Доставка товаров в соответствии с заявкой покупателей».

Пройдя, таким образом, по всем блокам и элементам, компания получает исходный перечень бизнес-процессов для построения процессной структуры предприятия. Впоследствии они ложатся в основу формирования системы целей компании, а также выступают в качестве базы для формирования системы КРІ для каждого конкретного сотрудника компании.

В качестве преимуществ внедрения системы КРІ можно назвать следующие:

- рост производительности труда и экономической эффективности предприятия (20-30% в течение первого года эксплуатации системы);
- рост удовлетворенности и квалификации персонала, снижение текучести кадров;
- достижение и укрепление конкурентных преимуществ предприятия;
- прояснение целей предприятия и функций подразделений (работников);
- улучшение внутрифирменного взаимодействия, снижение транзакционных издержек;
- повышение управленческой квалификации руководителей;
- формирование и развитие управленческой команды;
- развитие корпоративной культуры, ориентированной на реализацию ценностей компании.

Таким образом, система КРІ выступает в качестве современного инструмента стимулирования персонала, позволяющего достичь стратегические цели компании.

Использованные источники:

1. Банных М.В., Дубровский В.Ж. Опыт внедрения системы КРІ на предприятии // Форум молодых ученых. - 2019. - № 9 (37). - С. 40-48
2. Климова Д.Н., Поточкина С.А., Мананникова О.Н. Плюсы и минусы внедрения системы КРІ на российских предприятиях // Глобальные проблемы модернизации национальной экономики. Материалы VIII Международной научно-практической конференции. - 2019. - С. 382-391
3. Кулагин О. Целевое управление компанией. Как построить организацию, заточенную на результат. – М.: Издательские решения, 2019. – 340 с.
4. Рыбьянцева М.С. КРІ как основа повышения эффективности корпоративного управления // Экономика и предпринимательство. - 2020. - № 2 (115). - С. 1094-1100
5. Труфанова Т.А., Савенкова Е.А. Современные проблемы разработки и внедрения системы КРІ и пути их решения // Современные кадровые технологии в управлении предприятиями и территориями. Материалы IV международной научно-практической конференции. - 2019. - С. 162-169

*Кочанова А.А.
студент*

*Российская академия народного хозяйства и государственной службы
при Президенте Российской Федерации
Санкт-Петербург*

СОВРЕМЕННАЯ ПРАКТИКА МОТИВАЦИИ ПЕРСОНАЛА

Аннотация: В рамках исследования установлено, что руководители современных предприятий ориентируются на многообразные концепции мотивационного управления. Каждое конкретное предприятие должно использовать индивидуальную систему мотивации персонала, которая учитывает особенности его функционирования. При этом в основу ее разработки должны быть положены стратегические цели предприятия, основы корпоративной культуры и другие факторы. Только в данном случае можно достичь повышения конкурентоспособности предприятия за счет повышения мотивационных стимулов и наращивания производительности труда.

Ключевые слова: мотивация, виды мотивации, нематериальная мотивация, материальная мотивация, система премирования, индивидуальный подход

*Kochanova A.A.
student*

*Russian Presidential Academy of National Economy and Public
Administration
Saint-Petersburg*

MODERN PRACTICE OF PERSONNEL MOTIVATION

Abstract: Within the framework of the study, it is established that the managers of modern enterprises are guided by various concepts of motivational management. Each specific enterprise should use an individual system of personnel motivation, which takes into account the peculiarities of its functioning. At the same time, its development should be based on the strategic goals of the enterprise, the foundations of the corporate culture and other factors. Only in this case, it is possible to achieve an increase in the competitiveness of the enterprise by increasing motivational incentives and increasing labor productivity.

Keywords: motivation, types of motivation, non-material motivation, material motivation, bonus system, individual approach

Руководители предприятий ориентируются на многообразные концепции мотивационного управления. При этом в каждом конкретном случае необходимо формировать определенный набор методов и способов стимулирования труда, которые будут способствовать повышению удовлетворенности трудом сотрудников и росту производительности их труда.

Для выделения мотивационных типов работников используются специальные методы, которые применяются в следующей последовательности [1, с. 45]:

- проведение обучающих семинаров для аппарата управления, в ходе которых управленческая команда нацеливается на активную работу;

- диагностика типов мотивации сотрудников, которые сложились на предприятии. Для этого используется анализ документов, интервью, как с рядовыми сотрудниками, так и топ-менеджерами;

- анализ структуры типов мотивации сотрудников для определения наиболее оптимальных методов стимулирования их труда. На данном этапе принято использовать анкетирование;

- изучение особенностей оплаты труда, что позволяет сформировать оптимальную систему оплаты, которая учитывает ожидания и запросы сотрудников предприятия;

- разработка и обоснование постоянной части оплаты труда на предприятии, корректировка окладов, квалификационных надбавок и доплат;

- разработка и обоснование переменной части оплаты труда, т.е. разработка подходов к определению выплаты надбавок, бонусов и т.д.;

- анализ и обоснование социального пакета, на данном этапе формируются принципы его распределения;

- разработка неденежных видов и форм стимулирования, которые зависят от специфики трудовых процессов, опыта других предприятий и т.д.

Эффективная система стимулирования труда формируется только в том случае, если предприятие проходит через все названные этапы.

Для стимулирования труда персонала принято использовать два вида мотивационных стимулов:

- 1) материальная мотивация;
- 2) нематериальная мотивация.

Материальная мотивация – это материальное благо за определенный вклад работника в результат деятельности компании [2, с. 103].

К материальной относятся денежная и неденежная мотивация. Соответственно, денежная мотивация — это любые виды денежных выплат, а неденежная мотивация – это мотивация, когда используются те виды благ, которые не могут приобретаться за деньги [2, с. 103].

Важным элементом денежного стимулирования выступает система премирования, от которого зависит уровень производительности труда

персонала, качество выполнения сотрудниками своих функциональных обязанностей.

Помимо вопросов, при разработке эффективной системы материальной мотивации, должны быть учтены условия:

- индивидуальные различия в потребностях, ценностях, предпочтениях и ожиданиях разных работников;
- различия условий работы в разных организациях;
- изменения потребностей, предпочтений и ожиданий у одного и того же сотрудника в зависимости от изменений его возраста, жизненной ситуации;
- разнообразие теорий и систем стимулирования, которые необходимо оценить по степени эффективности.

Следует отметить, что использование материальной мотивации сопровождается рядом ограничений, в результате чего с течением времени сотрудник может стать менее заинтересованным в наращивании производительности. В связи с чем, материальное стимулирование должно сопровождаться нематериальным стимулированием.

Использование нематериальных стимулов к труду позволяет привлечь высококвалифицированных специалистов, снизить уровень текучести кадров, а также сформировать благоприятный психологический климат в коллективе.

Нематериальную мотивацию следует рассматривать как поощрение сотрудников, которое не использует материальные блага. Использование инструментов нематериального стимулирования позволяет повысить заинтересованность сотрудников в результатах их работы, повышении качества труда. Как следствие, это способствует улучшению результативности работы всего предприятия в целом. Приведем примеры инструментов нематериального стимулирования:

- корпоративные мероприятия;
- обеспечение возможностей для карьерного роста;
- стимулирование свободным временем;
- благодарность, как устная, так и письменная;
- описание заслуг работника в корпоративных средствах массовой информации;
- размещение фотографии сотрудника на стенде лучших работников предприятия и т.д.

Для разработки системы нематериальной мотивации нужно изучить все теоретические модели, принципы и методы мотивации персонала, которые есть на сегодняшний день. Важно обозначить вопросы, ответы на которые необходимо получить в процессе достижения желаемого результата. Не нужно забывать, что лучше использовать индивидуальный подход, нежели общий. Хорошим помощником, чтобы узнать, чего не хватает сотрудникам, станет анкетирование.

Сотрудники компании прекрасно знают, каких мотивационных факторов не хватает для того, чтобы они работали эффективно и, что называется, с душой. Поэтому, помимо анкетирования, имеет смысл организовать специальный «мозговой» штурм», чтобы сотрудники сами «набросали» идеи по разработке системы нематериального стимулирования.

При формировании конкретных мотивационных мероприятий необходимо знать все потребности, которые присущи сотрудникам компании и учитывать их индивидуальный темперамент. А прибегая к креативным мероприятиям и вдохновляя сотрудников на самомотивацию, можно обеспечить успешную результативную и здоровую атмосферу в компании [3, с. 78].

Каждое конкретное предприятие должно использовать индивидуальную систему мотивации, которая учитывает особенности его функционирования. При этом в основу ее разработки должны быть положены стратегические цели предприятия, основы корпоративной культуры и другие факторы. Только в данном случае можно достичь повышения конкурентоспособности предприятия за счет повышения мотивационных стимулов и наращивания производительности труда.

Российские компании, как отмечают аналитики, в большинстве своем предпочитают использовать для мотивации своих сотрудников материальные методы. При этом в качестве основного стимула выбирается заработная плата. Однако в последние годы все большее количество российских компаний стали использовать новые инструменты.

Использованные источники:

1. Березина В.П. Теоретические аспекты системы мотивации персонала // Экономика и государство: проблемы и перспективы развития. - 2020. - С. 45-50
2. Вагапова Ю.Р. Мотивация и стимулирование персонала // Вестник науки. - 2020. - Т. 3. - № 1 (22). - С. 103-105
3. Керашева С.А., Мокшин А.С. Мотивация труда персонала на предприятии // Актуальные проблемы развития экономики: менеджмент и маркетинг. Сборник статей Межвузовской научно-практической конференции. - 2020. - С. 74-78

*Кочко Н.А.
студент 3 курса
факультет «юридический»
РГУП*

*Россия, г. Иркутск
Семенникова В.В.*

*студент 3 курса
факультет «юридический»
РГУП*

*Россия, г. Иркутск
Кувалдин В.Д.*

*студент 3 курса
факультет «юридический»
РГУП*

Россия, г. Иркутск

*научный руководитель: Власова Е.Л., к.п.н.
доцент*

ОТВЕТСТВЕННОСТЬ ОРГАНОВ МЕСТНОГО САМОУПРАВЛЕНИЯ ПЕРЕД ФИЗИЧЕСКИМИ И ЮРИДИЧЕСКИМИ ЛИЦАМИ

Аннотация: В статье проанализирована ответственность органов местного самоуправления перед физическими и юридическими лицами

Ключевые слова: юридическая ответственность, местное самоуправление, власть, закон

*Kochko N. A.
3rd year student
Faculty of Law
of RSUP
Russia, Irkutsk
Semennikova V. V.
3rd year student
Faculty of Law
of RSUP
Russia, Irkutsk
Kuvaldin V. D.
3rd year student
Faculty of Law
of RSUP
Russia, Irkutsk*

RESPONSIBILITY OF LOCAL SELF-GOVERNMENT BODIES TO INDIVIDUALS AND LEGAL ENTITIES

Abstract: The article analyzes the responsibility of local self-government bodies to individuals and legal entities

Keywords: legal responsibility, local self-regulation, power, law

Местное самоуправление, как орган публичной власти, выступает одним из самых важных и главных демократических основ системы управления обществом, важнейшим элементом государственного устройства, а также формой осуществления народом, принадлежащей ему власти¹²⁷.

На сегодняшний день понятие «ответственность» может определяться в самых разных смыслах, содержаниях и контекстах. Не представляется возможным представить какое-то одно определение данного термина, хотя безусловно самое общее и оптимальное определение термина «ответственность» происходит от таких слов как «отвечать» и «ответ».

Юридическая ответственность выступает как «базовый элемент права, одна из наиболее значимых субстанций. Как один из ведущих и фундаментальных правовых институтов юридическая ответственность имеет глобальный характер, многосложный элементный состав, опирается на многие отрасли права, отличается значительным многообразием видов (разновидностей)».

Муниципальное право России на сегодняшний день считается довольно новой отраслью, это комплексная отрасль права — институтом которой выступает муниципально-правовая ответственность¹²⁸.

В большинстве своем это такой новый вид юридической ответственности, и большой интерес к нему в первую очередь обусловлен рядом следующих причин:

1. После принятия Конституции РФ в стране возродилось местное самоуправление, а по историческим меркам, это относительно недавно.

2. За все время своего существования местное самоуправление постоянно подвергалось различным реформам.

3. В последнее время в нашей стране именно местному самоуправлению придается все более значительное внимание.

¹²⁷ Анчин Г.В. Местное самоуправление трудное дитя России. // Государство и право. 2014. № 6. С. 49.

¹²⁸ Аминов И.Р., Кравченко Р.В. К вопросу о месте муниципального права в системе российского права. // Фундаментальные и прикладные исследования в современном мире. Санкт-Петербург 2014. Том: 4 . № 8 С. 102

4. Главным условием построения гражданского общества служит — правильно организованное управление местных органов.

5. Принятие Федерального закона от 6 октября 2003 г. № 131-ФЗ «Об общих принципах организации местного самоуправления в Российской Федерации»¹²⁹ дало начало очередному этапу реформирования.

Помимо ответственности органов местного самоуправления, которую они несут перед населением муниципального образования и перед государством, Федеральный Закон РФ «Об общих принципах организации местного самоуправления в РФ» также устанавливает в соответствии со ст. 50 ответственность, которая наступает перед физическими и юридическими лицами.

Органы местного самоуправления в пределах своей компетенции обязаны принимать обращения граждан, юридических лиц, рассматривать их в надлежащие сроки и в определенном порядке, установленные законом, давать на них мотивированные ответы, принимать меры по защите и восстановлению нарушенных прав граждан.

В основе местного самоуправления наблюдается право граждан городских и сельских поселений вносить свой вклад в регулирование вопросов жизнедеятельности населения муниципального образования. Ответственность органов и должностных лиц местного самоуправления является инструментом функционирования местного самоуправления в интересах не только всего общества, но и также рассматривает приоритеты отдельных физических лиц и организаций. Федеральный Закон РФ от 6.10.2003 «Об общих принципах организации местного самоуправления в РФ» регламентирует в ст. 50 ответственность, наступающую перед физическими и юридическими лицами.

Источником привлечения к ответственности являются противоправные действия (бездействие) органов и должностных лиц местного самоуправления, затрагивающие права и свободы граждан, причиняющие материальный и иной ущерб отдельным гражданам и юридическим лицам, вследствие чего такая ответственность носит характер гражданско-правовой ответственности. Благоразумно, что главным ориентиром применения установленного вида ответственности расценивается, как необходимость реконструировать эти нарушенные права и законные интересы.

Согласно ст.46 Конституции Российской Федерации каждому гарантируется судебная защита его прав и свобод. Действия, бездействия, решения, неправомерные отказы органов местного самоуправления и должностных лиц могут быть обжалованы в судебном порядке. Исходя из данного положения, был принят Федеральный Закон РФ от 27 апреля 1993

¹²⁹ Об общих принципах организации местного самоуправления в Российской Федерации : Федеральный закон от 06.10.2003 N 131-ФЗ (ред. от 09.11.2020) // СПС «КонсультантПлюс».

года «Об обжаловании в суд действий и решений, нарушающих права и свободы граждан»¹³⁰, в котором акцентируется идея, что решения и действия (или бездействие) органов местного самоуправления, должностных лиц местного самоуправления могут быть обжалованы в суд.

В современном обществе существуют проблемы, связанные с концепцией исполнения нормы ст.50 Федерального Закона РФ от 6 октября 2003г. «Об общих принципах организации местного самоуправления в РФ»¹³¹ в установлении ответственности с целью укрепления порядка и стабильности в обществе касательно органов и должностных лиц местного самоуправления перед физическими и юридическими лицами. К несчастью, вопрос о возложении ответственности не всегда устанавливается рационально по отношению к участникам рассматриваемых правоотношений.

Субъекты местной власти могут подлежать всем уровням юридической ответственности (дисциплинарной, административной, уголовной), тем не менее, участниками гражданского оборота они не являются, и как следствие этого, за незаконные действия (бездействие) должностных лиц, причиняющих вред физическому или юридическому лицу, несет ответственность муниципальное образование в целом (ст. 16 Гражданского Кодекса РФ)¹³².

На практике отмечается немало случаев, когда должностное лицо, в силу Устава местного самоуправления является юридическим лицом, в данном случае ответственность оно надлежит нести как организация.

Урон законного интереса, причиненный гражданину или юридическому лицу вследствие незаконных действий (бездействия) органов местного самоуправления либо должностных лиц местного самоуправления, а также в результате издания ненадлежащего закону акта, возмещается за счет казны муниципального образования согласно ст. 1069 ГК РФ.

Виды и формы подобных деяний весьма многообразны. Это могут быть всевозможные приказы, распоряжения, постановления, указания и иные властные предписания (безразлично, произведены они в письменной или устной форме), которые направлены гражданам и юридическим лицам и подлежат обязательному осуществлению¹³³.

Следующим основанием наступления ответственности органов и должностных лиц местного самоуправления выступает не исполнение условий договоров и соглашений с физическими и юридическими лицами,

¹³⁰ Конституция Российской Федерации 1993

¹³¹ Об общих принципах организации местного самоуправления в Российской Федерации : Федеральный закон от 06.10.2003 N 131-ФЗ (ред. от 09.11.2020) // СПС «КонсультантПлюс».

¹³² Гражданский кодекс Российской Федерации (ГК РФ) : от 30 ноября 1994 г. № 51-ФЗ // СПС «КонсультантПлюс»

¹³³ Ефремов Г.Г. Организационно-управленческие аспекты в деятельности органов местного самоуправления. // Муниципальная власть. 2013. № 1. С.52.

при осуществлении прав в качестве собственника касательно муниципального имущества, либо, реализуя право оперативного управления или хозяйственного ведения, занимаясь предпринимательской деятельности, если они являются юридическими лицами.

Необходимо учитывать, что ненадлежащее исполнение полномочий в некоторых случаях есть результат деятельности государственных органов. В частности, несоблюдение каких-либо сроков при исполнении договорных обязательств, когда местный орган власти в какой-то мере зависит от государственных органов.

В области гражданского оборота можно попасть под такие правовые движения, как предпринимательские риски и непреодолимые воздействия, при оценке ответственности органов и должностных лиц местного самоуправления перед физическими и юридическими лицами следует объективно сопоставить данные факты. В отдельных случаях не всегда можно устанавливать факт отражения социального воздействия-наложения ответственности на поведенческие отклонения.

С целью устранения оснований возложения незаконной ответственности следует соблюдать следующие критерии:

1. Преобладание девиантного поведения у органов муниципального образования.

2. Наличие ущерба от действий (бездействия) органов и должностных лиц местного самоуправления (ст.16 ГК РФ)

3. Причинная связь между ущербом и противоправным поведением. Оценка последовательной юридически значимой взаимосвязи между фактом противоправного поведения и наступившими последствиями.

4. Виновность органа или должностного лица местного самоуправления. Должны быть учтены все щепетильные моменты неправомерного поступка (подлежит ли к ответственности муниципальное образование в целом или же следует привлекать отдельное должностное лицо, а возможно и государственных органов).

5. Ответственность устанавливается, прежде всего, индивидуально, в отношении каждого субъекта местной управленческой деятельности, если же нет признаков публично-правовой ответственности.

Для стабилизации и укрепления правопорядка в области местного самоуправления и надлежащего установления ответственности следует усовершенствовать механизм регуляции правовой нормы по ст.50 Федерального Закона РФ от 6.10.2003 «Об общих принципах организации местного самоуправления в РФ». То есть, установить, за какие правонарушения и преступления по отношению к юридическим и физическим лицам несёт ответственность определённый орган или должностное лицо муниципального образования, а также государственные структуры с точки зрения рационализма, вдобавок необходимо изменить структуру ст.16 Гражданского Кодекса РФ.

Российская Федерация — есть правовое общество, в котором основной источник власти — это народ. Нарушение прав и законных интересов граждан и организаций — есть противоречие современной тенденции государства, в таком случае, в норме ст.50 Федерального Закона РФ от 6.10.2003 «Об общих принципах организации местного самоуправления в РФ» должна быть предусмотрена в обязательном порядке налагаемая мера пресечения на занятие определенной деятельностью и на состояние в определенной должности, как дополнительный метод социального воспитательного воздействия.

Подводя итог всему вышесказанному, можно сделать вывод о том, что данная ответственность органов местного самоуправления по отношению к физическим и юридическим лицам носит частноправовой характер, в отличие от публично-правовой ответственности, наступающей перед гражданским обществом и перед государством.

Использованные источники:

1. Об общих принципах организации местного самоуправления в Российской Федерации : Федеральный закон от 06.10.2003 N 131-ФЗ (ред. от 09.11.2020) // СПС «КонсультантПлюс».
2. Гражданский кодекс Российской Федерации (ГК РФ) : от 30 ноября 1994 г. № 51-ФЗ // СПС «КонсультантПлюс».
3. Муниципальное право РФ под ред. Кутафина О.Е., Фадеева В.И., М. 1997 г. С.434-445.
4. Абдуллина С.И., Аминов И.Р. Формы непосредственной демократии в местном самоуправлении: проблемы теории и практики. // Вопросы современной юриспруденции. Новосибирск 2014. № 37. С. 16-21.
5. Аминов И.Р., Кравченко Р.В. К вопросу о месте муниципального права в системе российского права. // Фундаментальные и прикладные исследования в современном мире. Санкт-Петербург 2014. Том: 4 . № 8 С. 102-105.
6. Анчин Г.В. Местное самоуправление трудное дитя России. // Государство и право. 2014. № 6. С. 49-54.
7. Ванев О.Н. Город и самоуправление: вопросы теории. - Красноярск: ИПЦ КГТУ, 2013. 181с.
8. Ефремов Г.Г. Организационно-управленческие аспекты в деятельности органов местного самоуправления. // Муниципальная власть. 2013. № 1. С.52- 54.
9. Ибрагимов Т.М., Аминов И.Р. К вопросу о международно-правовых источниках муниципального права. // Сборник материалов VI Международной научно-практической конференции «Перспективы развития научных исследований в 21 веке», Махачкала 2014 года. С. 116-120.

*Кузеванов Е.Е.
преподаватель физической культуры
Алтайский транспортный техникум
Россия, Барнаул*

**МЕТОДИЧЕСКИЕ РЕКОМЕНДАЦИИ ПО РАЗРАБОТКЕ
ПЛАНИРУЕМЫХ РЕЗУЛЬТАТОВ ОСВОЕНИЯ РАБОЧЕЙ
ПРОГРАММЫ «ФИЗИЧЕСКАЯ КУЛЬТУРА»**

Аннотация. В статье даются методические рекомендации по разработке планируемых результатов освоения рабочей программы «Физическая культура» Автором подчеркивается идея о том, что при разработке планируемых результатов преподавателю физической культуры необходимо ориентироваться на разделы программы учебной дисциплины и описывать их на уровне: целевых установок; основных учебных действий и дополнительных учебных действий.

Ключевые слова: успеваемость, физическая культура, планируемые результаты, студенты.

*Kuzevanov E.E.
physical education teacher
Altai Transport College
Barnaul*

**METHODOLOGICAL RECOMMENDATIONS FOR THE
DEVELOPMENT OF THE PLANNED RESULTS OF THE
DEVELOPMENT OF THE WORK PROGRAM "PHYSICAL
CULTURE"**

Abstract: The article gives methodological recommendations for the development of the planned results of mastering the work program "Physical culture" The author emphasizes the idea that when developing the planned results, the teacher of physical culture should focus on the sections of the program of the discipline and describe them at the level of: target settings; basic instructional activities and additional instructional activities.

Key words: academic performance, physical education, planned results, students.

В структуре предметно-профессиональной деятельности преподавателя физической культуры разработка планируемых результатов выступает одной из значимых форм работы. В последние годы в помощь преподавателям выпускаются различные методические рекомендации,

пособия и руководства по вопросам организации учебного процесса[1, 2, 3, 4].

При самостоятельной разработке или адаптации содержания заимствованных планируемых результатов по дисциплине «Физическая культура» преподавателю предлагается ориентироваться на структурные компоненты учебной дисциплины:

- систему базовых элементов научного знания, выражающуюся в совокупности знаний по физической культуре, ее становлению, развитию современному состоянию, теории и методике занятий физическими упражнениями, способам самостоятельной организации физкультурно-оздоровительной и спортивно-оздоровительной деятельности (компонент «Знания о физической культуре»);

- систему приёмов, способов и действий, которая проявляется в умениях и навыках самостоятельной организации и проведения занятий физической культурой, их планированию, контролю и коррекции функциональной направленности содержания (компонент «Способы двигательной (физкультурной) деятельности»);

- систему средств физической культуры и спорта, которая включает в себя совокупность технических приёмов, действий и физических упражнений, ориентированных на совершенствование физической природы человека, укрепление его здоровья и др. (раздел «Физическое совершенствование»).

В дополнение к этому преподавателю необходимо ориентироваться на общепедагогические рекомендации, предлагающие описывать планируемые результаты на следующих уровнях:

- уровень целевых установок;
- уровень основных учебных действий;
- уровень дополнительных учебных действий.

Охарактеризуем указанные уровни.

Уровень целевых установок включает в себя ожидаемые результаты изучения учебной дисциплины «Физическая культура» по определенной рабочей программе. Это обусловлено тем, что каждый составитель, с опорой на целевые установки примерной рабочей программы, определяет задачи собственной рабочей программы и, учитывая их, формирует учебный материал. Можно прийти к выводу, что ожидаемые результаты при освоении рабочих программ у авторов-составителей будут различны. Вышеобозначенный уровень описания планируемых результатов необходим, чтобы видеть различия между рабочими программами разработчиков.

Таким образом, уровень целевых установок выполняет вводную функцию, знакомя преподавателя с содержанием определенной рабочей программы. В этой связи уровень целевых установок включается в

содержание рабочей программы и предваряет описание следующих уровней планируемых результатов.

Уровень основных учебных действий позволяет определить сформированность учебных действий (знания, умения и навыки), необходимых обучающимся для освоения учебного материала на последующей ступени образования.

Данные планируемые результаты объединяются в отдельные блоки внутри раздела «Выпускник научится», разрабатываемого к каждому компоненту рабочей программы. Отличительной особенностью обозначенных планируемых результатов выступает возможность их оценки, как в процессе итогового контроля, так и в рамках текущего и промежуточного контроля. Подчеркнем, что разработка планируемых результатов указанного уровня, и заданий, направленных на проверку их достижения является одним из значимых этапов в деятельности авторов рабочих программ. Отметим, что преподаватели физической культуры имеют возможность использования планируемых результатов данного уровня и учебных заданий для оценки успеваемости студентов по отдельным темам и компонентам (разделам) рабочей программы, выявления качества его освоения и при необходимости внесения изменений в тематическое планирование.

Следующий уровень – уровень дополнительных учебных действий. Связан с углублением содержания программного материала, предусмотренного планируемыми результатами уровня основных учебных действий. Данный уровень, который группирует планируемые результаты для каждого раздела программы в блок «Выпускник научится», вводится для решения, как минимум, двух принципиально важных задач. Первая задача связана с углублённым изучением физической культуры в системе профессионального образования, где физическая культура входит в число предметов профессионально-ориентированной подготовки. Вторая задача связана с удовлетворением личных интересов обучающихся в активном использовании средств физической культуры для укрепления своего здоровья и организации активного отдыха и досуга. Подчеркнем, что достижение планируемых результатов указанного уровня не является обязательным для студентов.

Подводя итог вышеизложенному, отметим, что в процессе разработки планируемых результатов преподаватель физической культуры должен ориентироваться на разделы программы учебной дисциплины и описывать их на уровнях: целевых установок; основных учебных действий и дополнительных учебных действий. Разработка планируемых результатов и учебных заданий по проверке их достижения, является одной из инновационных форм профессиональной деятельности преподавателя физической культуры.

Использованные источники:

1. Аллянов, Ю. Н. Физическая культура : учебник для СПО / Ю. Н. Аллянов, И. А. Письменский. – 3-е изд., испр. – Москва : Издательство Юрайт, 2019. – 493 с.
2. Бишаева, А.А. Физическая культура : учебник для студ. учреждений сред.проф. образования / А.А.Бишаева. – 2-е изд., стер. – Москва : Издательский центр «Академия», 2017. – 320 с.
3. Виленский, М.Я. Физическая культура: учебное пособие / М.Я. Виленский. – Москва : Издательство Кронус, 2016. – 214 с.
4. Муллер, А.Б. Физическая культура : учебник и практикум для среднего профессионального образования / А. Б. Муллер [и др.]. – Москва : Издательство Юрайт, 2019. – 424 с.

*Кулакова О.А.
студент магистратура 3 курса
38.04.01 «Экономика»*

*Федеральное государственное бюджетное образовательное
учреждение высшего образования «Костромской государственный
университет» (КГУ)
РФ, г. Кострома*

К ВОПРОСУ О ПРАВЕ ПОДПИСИ ПРИ ВЕДЕНИИ БУХГАЛТЕРСКОГО УЧЕТА КОНСАЛТИНГОВОЙ ФИРМОЙ

Аннотация: В статье подробно рассмотрен перечень лиц, имеющих право подписи при ведении бухгалтерского учета консалтинговой фирмой. Уделено внимание нормативному регулированию права на подпись документов специалисту консалтинговой фирмы. Нормы права, рассмотрены касательно первичных учетных, кассовых документов, а также счетов-фактур.

Ключевые слова: консалтинговая фирма, право подписи, первичный учетный документ, кассовые документы, счет-фактура.

*Kulakova O.A.
master's degree 3rd year
38.04.01 "Economics"*

*Federal State Budgetary Educational Institution of Higher Education
"Kostroma State University" (KSU)
Russian Federation, Kostroma*

ON THE ISSUE OF THE RIGHT TO SIGN WHEN CONDUCTING ACCOUNTING BY A CONSULTING FIRM

The article discusses in detail the list of persons who have the right to sign in accounting by a consulting firm. Attention is paid to the normative regulation of the right to sign documents to a specialist of a consulting firm. The rules of law are considered regarding primary accounting, cash documents, as well as invoices.

Key words: consulting firm, signature right, primary accounting document, cash documents, invoice.

Организации, прибегающие к услугам консалтинговых агентств, в своей практике зачастую сталкиваются с вопросом: кто же должен подписывать кассовые документы, в первичных учетных документах, счетах-фактурах за главного бухгалтера, если в штатном расписании его

должность не указана? Может ли руководитель фирмы подписывать указанные документы или же подписи должны ставить руководитель или бухгалтер консалтинговой фирмы по доверенности?

Законодатель указывает, что руководитель экономического субъекта обязан возложить ведение бухгалтерского учета на главного бухгалтера или иное должностное лицо этого субъекта либо заключить договор об оказании услуг по ведению бухгалтерского учета, если иное не предусмотрено ч. 3 ст. 7 Федерального закона от 06.12.2011 № 402-ФЗ «О бухгалтерском учете» [7].

Пункт 1 статьи 9 Федерального закона о бухгалтерском учете устанавливает, что каждый факт хозяйственной жизни организации оформляется первичным учетным документом. В пункте 2 законодатель конкретизирует обязательные реквизиты первичного учетного документа. К ним, в частности, относятся наименование должности лица (лиц), который ответственен за осуществление факта хозяйственной жизни и оформление рассматриваемых документов; а также необходимо обязательное наличие подписи, фамилий и инициалов таких лиц.

В части 3 статьи 9 рассматриваемого закона, лицо, указанное в первичных учетных документах как ответственное, обязано обеспечить достоверность содержащихся в них данных, своевременность передачи документов для их регистрации и отражении в регистрах бухгалтерского учета организации. При этом закон четко указывает, что лицо, на которое возложено ведение бухгалтерского учета в организации, и лицо, с которым заключен договор об оказании услуг по ведению бухгалтерского учета, не несут ответственность за соответствие составленных другими лицами первичных учетных документов свершившимся фактам хозяйственной жизни [7].

Приказом Минфина России №34н установлено, что перечень лиц, которые имеют право подписывать первичные учетные документы, должен утверждать руководитель организации. Таким образом, нормы Федерального закона о бухгалтерском учете допускают возможность подписания первичного учетного документа несколькими лицами, однако и не устанавливает жесткого требования в данном вопросе [4].

Комитет по рекомендациям Фонда «НРБУ «БМЦ» 06.04.2020 утвердил рекомендации Р-113/2020-КпР «Первичные учетные документы в условиях удаленной работы», которые гласят, что для соблюдения требований законодательства о бухгалтерском учете на первичном учетном документе достаточно наличия одной подписи ответственного лица в организации за совершение сделки, операции, за ее оформление либо за оформление свершившегося события. Дополнительные подписи на документе (бухгалтера, контрагента и др.) допускаются, но не требуются [5]. Таким образом, должностное лицо консалтинговой фирмы, ответственный за составление первичного учетного документа и сделки,

которую данный документ подтверждает, может пописать данный документ с обязательным удостоверением личности.

Гражданское законодательство России понимает под доверенностью письменное уполномочие представительства интересов одних лиц перед третьими лицами, при этом нормы Гражданского кодекса применимы и в случае содержания полномочий представителя в договоре, если иное не ограничено действующими законами и не противоречит сущности отношений [1].

Итак, вышеуказанное позволяет сделать вывод, что передачу права подписи первичных учетных документов должностному лицу консалтинговой фирмы можно закрепить в договоре на ведение бухгалтерского учета. Договор должен содержать положения о передаче права подписи за главного бухгалтера конкретному лицу с обязательным указанием его должности в консалтинговой фирме, фамилии, имени, отчества и паспортных данных, а также перечень документов, которые сотрудник консалтинговой фирмы имеет право подписывать. Это же касается и права подписи кассовых документов.

Центробанк России в указании от 11.03.2014 № 3210-У регламентирует, что кассовые документы оформляются главным бухгалтером, бухгалтером или иным уполномоченным лицом (в том числе и сотрудником консалтинговой фирмы, при наличии соответствующего договора), а в случае отсутствия указанных лиц – руководителем предприятия [6].

Таким образом, должностное лицо консалтинговой фирмы (руководитель или главный бухгалтер, иное лицо) вправе подписывать кассовые документы общества за главного бухгалтера при наличии на то соответствующих полномочий.

Необходимо также рассмотреть такой документ, как счет-фактура. Налоговый кодекс Российской Федерации в п. 1 ст. 169 определяет счет-фактуру, как документ, являющийся основанием для принятия покупателем предъявленных ему продавцом товаров (работ, услуг) сумм НДС к вычету. П.6 рассматриваемой статьи конкретизирует, что право подписи счета-фактуры имеет руководитель организации, главный бухгалтер или иное уполномоченное лицо (в том числе и сотрудником консалтинговой фирмы, при наличии соответствующего договора) [2].

Однако Минфин РФ в письме от 24.07.2019 № 03-07-11/55067 обращает внимание, что отсутствует запрет на подписание счета-фактуры одним лицом, наделенным правом подписи на основании доверенности, как за руководителя, так и за главного бухгалтера организации [3]. Следовательно, счет-фактуру имеет право подписывать лицо, не являющемуся работником организации, на основании доверенности.

Вышесказанное позволяет сделать вывод, что в случае привлечения сторонней организации для ведения бухучета подпись главного бухгалтера

в кассовых документах, первичных учетных документах, счетах-фактурах управляющей организации проставляет должностное лицо консалтинговой фирмы (это может быть ее руководитель, главный бухгалтер, иное лицо) в том случае, если данному лицу, в том числе по доверенности, передано право подписывать за главного бухгалтера общества соответствующие документы. Если право подписи за главного бухгалтера общества стороннему лицу не передано, за главного бухгалтера может расписываться руководитель. Право подписи за главного бухгалтера можно также передать путем оформления соответствующей доверенности (с целью подписания счетов-фактур доверенность оформляется обязательно).

Использованные источники:

1. Гражданский кодекс Российской Федерации (часть первая) от 30.11.1994 № 51-ФЗ (ред. от 08.12.2020) // Официальный интернет-портал правовой информации. – URL: <http://pravo.gov.ru> (дата обращения 18.12.2020)
2. Налоговый кодекс Российской Федерации (часть вторая) от 05.08.2000 # 117-ФЗ (ред. от 23.11.2020) // Официальный интернет-портал правовой информации. – URL: <http://pravo.gov.ru> (дата обращения 18.12.2020)
3. Письмо Минфина России от 24.07.2019 № 03-07-11/55067 «О подписании счетов-фактур одним лицом, наделенным правом подписи на основании доверенности, за руководителя и главного бухгалтера» // Официальный интернет-портал правовой информации. – URL: <http://pravo.gov.ru> (дата обращения 18.12.2020)
4. Приказ Минфина России от 29.07.1998 № 34н (ред. от 11.04.2018) «Об утверждении Положения по ведению бухгалтерского учета и бухгалтерской отчетности в Российской Федерации» // Официальный интернет-портал правовой информации. – URL: <http://pravo.gov.ru> (дата обращения 18.12.2020)
5. Рекомендация Р-113/2020-КпР «Первичные учетные документы в условиях удаленной работы» // Бухгалтерский методологический центр: официальный сайт. URL: <http://www.bmcenter.ru> (дата обращения: 18.12.2020).
6. Указание Банка России от 11.03.2014 № 3210-У (ред. от 05.10.2020) «О порядке ведения кассовых операций юридическими лицами и упрощенном порядке ведения кассовых операций индивидуальными предпринимателями и субъектами малого предпринимательства» // Официальный интернет-портал правовой информации. – URL: <http://pravo.gov.ru> (дата обращения 18.12.2020)
7. Федеральный закон от 06.12.2011 № 402-ФЗ (ред. от 26.07.2019) «О бухгалтерском учете» // Официальный интернет-портал правовой информации. – URL: <http://pravo.gov.ru> (дата обращения 18.12.2020)

*Кулакова О.А.
студент магистратура 3 курса
38.04.01 «Экономика»*

*Федеральное государственное бюджетное образовательное
учреждение высшего образования «Костромской государственный
университет» (КГУ)
РФ, г. Кострома*

АНАЛИЗ СОВРЕМЕННЫХ ПРОБЛЕМ НА РЫНКЕ ЮВЕЛИРНОЙ ОТРАСЛИ

Аннотация: Проведенное исследование опирается на мнения руководителей предприятий ювелирной отрасли. Целью исследования послужила сложившаяся ситуация на ювелирном рынке. Стагнация экономики России, снижение материального достатка граждан, у которых меняются приоритеты и не остаётся денег на ювелирные украшения являются основными проблемами ювелирной отрасли.

Ключевые слова: ювелирные изделия, государственное регулирование ювелирного рынка, ценообразование ювелирных изделий.

*Kulakova O.A.
master's degree 3rd year
38.04.01 "Economics"*

*Federal State Budgetary Educational Institution of Higher Education
"Kostroma State University" (KSU)
Russian Federation, Kostroma*

ANALYSIS OF CURRENT PROBLEMS IN THE JEWELRY INDUSTRY MARKET

The conducted research is based on the opinions of the heads of the jewelry industry enterprises. The aim of the study was the current situation in the jewelry market. The stagnation of the Russian economy, a decrease in the material well-being of citizens who change their priorities and have no money left for jewelry are the main problems of the jewelry industry.

Key words: jewelry, government regulation of the jewelry market, jewelry pricing.

Ситуация на рынке, отвечающем за производство и реализацию ювелирных изделий на территории страны, отмечена значительным падением покупательской способности, вплоть до 1/5 от предыдущих показателей, по оценкам экспертов за прошлый год, не зависимо от

материала, из которого произведены украшения, вызванное внешними (рост курса валют) и внутренними (рост безработицы на фоне пандемии) экономическими факторами. Сложившаяся ситуация – в которой покупка ювелирных изделий отодвигается потребителем на задний план, вынуждает производителя понижать цену реализации, произведенных ювелирных изделий.

Рассмотрим системные проблемы отрасли. Во-первых, связанная с исполнением федерального закона № 115. Чтобы избежать нарушения законодательства, продавец вынужден заниматься сбором персональных данных покупателя, в дальнейшем передавая собранную информацию в РосФинМониторинг. Проблема состоит в отсутствии четко регламентированной нормативным актом документации. Ее внушительный объем, в таких условиях, приводит к ошибкам и подозрениям, со стороны контролирующих органов, как следствие к большим штрафам, аресту расчетного счета организации при малейшем подозрении. Во-вторых, огромная фискальная нагрузка на все стадии производственного процесса и продажу изделия, увеличивающая цену реализации продукции. Это создает почву для процветания нелегального импорта изделий и сырья из Турции или Азиатских стран. Создается нечестная конкурентная среда, приводящая к ликвидации бизнеса честных налогоплательщиков. В-третьих, отсутствие условий для создания масштабного сетевого рынка реализации через интернет магазины, так как курьерская служба должна быть лицензирована. Еще это вызвано обязательным наличием пробы на ювелирном изделии, то есть контакта с пробирной инспекцией.

С учетом указанных негативных факторов, повышающих цену реализации и в обстановке снижения покупательской способности, происходит ухудшение финансового состояния ювелирного производства и, как следствие, упадок финансового состояния ювелирной промышленности в целом.

В целях создания позитивной обстановки в финансовой сфере отрасли производства ювелирных изделий, рассмотрим ряд вопросов, и комплекс мер государственного реагирования для их решения.

Первый вопрос. В ЕАЭС существует отличие в отраслевых законодательствах, соответственно различаются условия производства и оборота ювелирных изделий в государствах – участников Евразийского экономического союза. В частности, различный подход к законопроекту о легализации и обороту финансов, полученных незаконным путем. На территории Армении ювелирные изделия не попадают в поле деятельности настоящего законопроекта, в отличие от остальных государств – участников Евразийского экономического союза, включающих оборот ювелирных изделий. В России подход к этой проблеме значительно строже, чем международные стандарты по противодействию отмыванию денег, что в конечном итоге, из-за административных издержек, приводит к увеличению

цены на ювелирные изделия, то есть делает их неконкурентоспособными на внутреннем и внешних рынках.

Изменение российского законодательства в отношении правил оборота ювелирных изделий в сфере противодействия отмыванию финансовых средств, полученных незаконным путем, послужило бы решением этого вопроса. Конечно с соблюдением национальных интересов в сфере развития сектора драгоценных камней и драгоценных металлов, с соответствующей международным стандартам ФАТФ корректировкой. А именно отмена обязательной идентификации покупателей, осуществляющим безналичный расчет, отмена обязательной идентификации контрагента, при совершении сделок купли-продажи с юридическими лицами и индивидуальными предпринимателями, имеющих лицензию на операции с драгоценными камнями и драгоценными металлами, состоящих на специальном учете ФКУ «Российская государственная пробирная палата при Министерстве финансов Российской Федерации», высвободить производство и оборот серебряных ювелирных изделий, из-под юрисдикции законодательства в сфере противодействия отмыванию средств, полученных незаконным путем.

Второй вопрос связан с предоставлением права на аффинаж драгоценных металлов. Очистку драгоценных металлов могут осуществлять только организации, утвержденные перечнем Правительства РФ, в соответствии Федеральному закону от 26.03.1998 № 41-ФЗ «О драгоценных металлах и драгоценных камнях». Ювелиры вынуждены обращаться к посредникам, так как очистка небольших партий лома нерентабельна. Аффинажные предприятия удовлетворяют свои потребности за счет собранного лома посредником, продавая в качестве сырья очищенный драгоценный металл небольшими партиями. Это способствует росту себестоимости ювелирных изделий. Осуществлять самостоятельно аффинаж драгметаллов ювелирные предприятия не имеют законных оснований. Хотя они снабжены необходимым оборудованием и там созданы соответствующие условия.

Ситуацию в данном вопросе изменило бы лицензирование аффинажа драгоценных металлов, взамен существующего перечня аффинажных предприятий, что сократило бы лишнее звено, в лице посредника, сэкономило расходы по перевозке и промежуточному хранению сырья.

Третий вопрос связан с налогообложением на слитки драгоценных металлов. Операции по реализации содержащей драгметаллы руды и лома драгметаллов для аффинажа, реализация драгметаллов Госфонду РФ и банкам, реализация их из Госфонда РФ, реализация их банками внешнеторговым организациям, а также операции со слитками драгоценных металлов между банками на сегодняшний день в России не облагается НДС, обложение НДС происходит в момент продажи драгоценных металлов производителям ювелирных и иных изделий из драгметаллов. Данный

фактор влияет на увеличение объема оборотных средств, требуемых для непрерывного производственного цикла.

Для уменьшения объема и возобновляемости оборотных средств предприятия производителя ювелирных изделий, положительно повлияющее на объемах производства и экспорта выпускаемой продукции, может быть обнуление ставки НДС при покупке слитков очищенных драгоценных металлов. При условии продажи продукции на внутреннем рынке налог будет уплачен в государственную казну в полном объеме.

Четвертый вопрос связан с обязательным клеймением ювелирных изделий из драгоценных металлов, при поставках на экспорт, подлежащих обязательному клеймению наравне с изделиями, поставляемыми на российский внутренний рынок. в соответствии ст.12.1. Федерального закона № 41 «О драгоценных металлах и драгоценных камнях». Необоснованное подорожание государственных пошлин за клеймение и опробование в 2017 году от двукратного за обычные ювелирные изделия и четырехкратного за клеймение изделий со вставками, увеличивает себестоимость продукции ювелирного производства, снижая возможность конкурировать с импортными изделиями на внутреннем рынке. На внешнем рынке ювелирных изделий опробование и клеймение по стандартам РФ не признается, что так же влияет на конкурентные качества ювелирных изделий.

Добиться снижения негативного эффекта позволит поэтапная реформация опробования и клеймения по стандартам РФ. Снижение и уравнивание государственной пошлины на опробование и клеймение простых ювелирных изделий и со вставками, изменение обязательного порядка на опробование и клеймение ювелирных изделий с обязательного на добровольный, с отменой минимального веса клеймения ювелирных изделий на экспорт, а в дальнейшем перейти на IT маркировку, с учетом перехода на электронный документооборот и контроль за оборотом драгоценных металлов, соответствующий мировым стандартам.

Из-за разных ввозных пошлин среди стран- участниц ЕАЭС возникает пятый вопрос. На данный момент пошлина на экспорт ювелирных изделий в Республику Казахстан понижена, в Республику Армения нулевая, вместе с тем ввозные пошлины на драгоценные камни для вставок в изделия на территорию Российской Федерации и Республику Беларусь достигает от 10% до 15%, ставя отечественного производителя ювелирных изделий в невыгодное положение, относительно других участников рынка ювелирных изделий ЕАЭС.

Одинаковые для всех участников ЕАЭС ввозные пошлины на все виды вставок для ювелирных изделий из драгоценных, полудрагоценных и синтетических камней, по примеру ввозных пошлин в Республику Армения, позволит найти решение для данного вопроса.

Отсутствие условий для создания масштабного сетевого рынка реализации через интернет магазины ставит перед нами шестой вопрос. Отсутствие отвечающего современным запросам законодательства в сфере торговли через сеть интернет, а также затруднение доставки, приобретенной ювелирной продукции, разрешенной только средствами специальной связи. На данный момент торговля через сеть интернет ювелирной продукцией запрещена законом, влечет за собой штрафные санкции, такие как блокировка сайта продавца.

Принять на законодательном уровне меры поддержки торговли на электронных площадках ювелирными изделиями, в том числе и на зарубежных рынках, включая решение вопроса, связанного с доставкой.

Седьмой вопрос связан с оформлением экспорта ювелирных изделий. Таможенное законодательство в нашей стране предполагает две ступени заполнения деклараций, причем с дублированием комплектов документов на экспортируемые изделия, с осуществлением контроля структурами Министерства финансов, отнимающее время на заполнение. Проблемы реимпорта при обратном пересечении границы.

Формирование структуры, позволяющей идентифицировать возвращаемые изделия при оформлении таможенного режима реимпорта, освобождая от уплаты ввозных таможенных пошлин, также создание единого комплекта документов в электронном виде для прохождения таможенного и государственного контроля.

Таким образом, рассмотрев деятельность государства в сфере ограничения ювелирного рынка Российской Федерации, можно отметить, что дополнительные издержки ювелирных предприятий, которые несут предприятия за счет всех требований предъявляемым к ним государством, оказывают значительное влияние на ценообразование ювелирных изделий и как следствие на конечную цену изделия. В связи со стагнацией экономики страны, спрос на ювелирные изделия снижается, что вынуждает предприятия снижать цену на изделия, за частую лишь покрывая свои издержки, а то и работая в убыток себе. В первую очередь именно политика государства в сфере обращения драгоценных металлов и камней оказывает решающее значение на ценообразование ювелирных изделий.

Использованные источники:

1. Ювелирная отрасль России: проблемы и вызовы нового времени [Электронный ресурс] // Всероссийский выставочный журнал-каталог «Экспо-Ювелир». – 2020. – №10 – Электронные данные. – М., [2005-2020]. – Режим доступа: <https://exrojeweller.ru/> - Заглавие с экрана – (дата обращения 10.12.2020)
2. Россия в цифрах. 2020: Крат. стат. сб./ Росстат- М., 2020 – 550 с.

*Куликов И.А.
студент магистратуры
научный руководитель: Саталкина Е.В., канд. экон. наук
доцент
Оренбургский государственный университет*

ОБЗОР НОРМАТИВНОГО РЕГУЛИРОВАНИЯ БУХГАЛТЕРСКОГО УЧЁТА РАСХОДОВ В СОВРЕМЕННЫХ ЭКОНОМИЧЕСКИХ УСЛОВИЯХ

Аннотация: В статье проведено исследование нормативного регулирования учёта расходов организации. Выявлены недостатки действующего законодательства в области учёта расходов.

Ключевые слова: бухгалтерский учёт, нормативное регулирование, расходы

*Kulikov I.A.
master student
Academic adviser: Satalkina E.V., PhD in Economics
Associate Professor
Orenburg State University*

OVERVIEW OF THE REGULATORY REGULATION OF ACCOUNTING OF EXPENSES IN THE MODERN ECONOMIC CONDITIONS

Abstract: The article studies the normative regulation of the organization's expenses accounting. The shortcomings of the current legislation in the field of cost accounting are revealed.

Keywords: accounting, regulation, expenses

В современных экономических условиях, любая организация стремится к достижению наибольшего эффекта с наименьшими расходами. Важная роль в управлении расходами принадлежит бухгалтерскому учёту. Учёт расходов – важнейший инструмент управления предприятием, необходимость в нем растёт по мере того, как усложняются условия хозяйственной деятельности и возрастает потребность в росте прибыли и рентабельности.

Объём и качество формируемой учётной информации зависит от многих факторов, в том числе рациональной и корректной с точки зрения соответствия действующему законодательству организации бухгалтерского

учёта, с этой целью первостепенное значение имеет исследование базы их нормативно-правового регулирования.

В российской практике система нормативно-правового регулирования бухгалтерского учёта расходов на текущий момент включает в себя несколько уровней: законодательный, нормативный, методический и организационный.

Законодательный уровень представлен рядом следующих нормативных актов:

1 Гражданский кодекс Российской Федерации, определяющий правовое положение участников гражданского оборота, регулирует договорные и другие обязательства, являясь основой правового регулирования предпринимательской деятельности в РФ [1].

2 Налоговый кодекс Российской Федерации, регламентирующий порядок формирования расходов в налоговом учёте, требования для признания расходов в целях налогообложения, а также предоставляющий классификацию расходов в зависимости от их характера, условий осуществления и направлений деятельности организации [2].

3 Федеральный закон «О бухгалтерском учёте» №402-ФЗ является основой регулирования организации и ведения бухгалтерского учёта в РФ. Он даёт определения основным понятиям, которые используются в бухгалтерском учёте, определяет сферу действия данного закона, основные требования к организации бухгалтерского учёта на предприятиях. В Законе даны наиболее общие положения, касающиеся учёта фактов хозяйственной жизни, активов, обязательств, источников финансирования деятельности предприятия, доходов, расходов и иных объектов, а именно: обязанность ведения бухгалтерского учёта (ст. 6), организация бухгалтерского учёта (ст. 7), правила формирования и применения учётной политики организации (ст. 8), оформление первичных учётных документов (статья 9), регистров бухгалтерского учёта (ст. 10), правила проведения инвентаризации обязательств и их отражения в бухгалтерской отчётности (ст. 11, 13), организация внутреннего контроля у субъекта хозяйствования (ст. 19), хранение документов (ст. 29) и др. [3].

К документам следующего, нормативного, уровня относятся:

1 Положение по бухгалтерскому учёту «Расходы организации» (ПБУ 10/99) – является основным документом, устанавливающим правила и процедуры, по которым формируют информацию о расходах организации в бухгалтерском учёте и отчётности.

В соответствии с п. 2 ПБУ 10/99 «Расходы организации» расходами организации признается уменьшение экономических выгод в результате выбытия активов (денежных средств, иного имущества) и (или) возникновения обязательств, приводящее к уменьшению капитала этой организации, за исключением уменьшения вкладов по решению участников (собственников имущества) [4].

Для целей бухгалтерского учёта все расходы классифицируются по видам затрат. Так, в соответствии с п. 4 ПБУ 10/99 «Расходы организации» расходы организации в зависимости от их характера, условий осуществления и направлений деятельности подразделяются на:

- расходы по обычным видам деятельности;
- прочие расходы.

Расходами по обычным видам деятельности являются расходы, связанные с изготовлением и продажей продукции, приобретением и продажей товаров (выполнением работ, оказанием услуг). При формировании расходов по обычным видам деятельности должна быть обеспечена их группировка по следующим элементам:

- материальные затраты;
- затраты на оплату труда;
- отчисления на социальные нужды;
- амортизация;
- прочие затраты

Согласно п. 16 данного Положения, расходы признаются в бухгалтерском учёте при наличии следующих условий:

- расход производится в соответствии с конкретным договором, требованием законодательных и нормативных актов, обычаями делового оборота;
- сумма расхода может быть определена;
- имеется уверенность в том, что в результате конкретной операции произойдёт уменьшение экономических выгод организации.

Если в отношении любых расходов, осуществлённых организацией, не исполнено хотя бы одно из названных условий, то в бухгалтерском учёте организации признается дебиторская задолженность.

2 Приказ Минфина России № 34н «Об утверждении Положения по ведению бухгалтерского учёта и бухгалтерской отчётности в Российской Федерации». Организация учёта расходов в нем определяется несколькими пунктами. Пункт 28 Положения регламентирует порядок учёта выявленных расхождений при инвентаризации активов, суммы которых списываются на финансовый результат организации. Пункт 77 определяет учёт дебиторской задолженности, с истёкшим сроком исковой давности, и долги, нереальные для взыскания, относящиеся на счёт средств резерва сомнительных долгов, либо на финансовые результаты [5].

К методическому уровню системы нормативного регулирования относится План счетов бухгалтерского учёта финансово-хозяйственной деятельности организаций и Инструкция по его применению, в котором системно развиты базовые нормы и процедуры Положений.

Последний, организационный уровень представлен внутренними рабочими документами, разрабатываемыми самим предприятием – это учётная политика, внутренние формы отчётности и другие документы.

Несмотря на постоянное совершенствование нормативно-правовой базы регулирования учёта расходов, она не лишена недостатков. В частности, многими учёными отмечается отсутствие чёткого разграничения терминов «расходы» и «затраты», местами их неверная трактовка; отсутствие определения некоторых конкретных, необходимых правил. Предполагается, что новый федеральный стандарт, разрабатываемый Минфином в настоящее время, и который согласно Приказу Минфина России от 05.06.2019 № 83н заменит действующее ПБУ 10/99 в 2023 г., будет лишён их.

Таким образом, проведённое исследование системы нормативного регулирования бухгалтерского учёта расходов позволяет сделать вывод, что расходы – это те факты хозяйственной жизни, которые с бухгалтерской точки зрения уменьшают финансовый результат предприятия. В настоящее время действует обширный перечень нормативных актов, которые оказывают влияние на учёт и состав расходов предприятий. Основным документом, которым регламентируются критерии классификации расходов и правила формирования расходов в бухгалтерском учёте является Положение по бухгалтерскому учёту ПБУ 10/99 «Расходы организации». Основная задача бухгалтерского учёта расходов сводится к определению их величины, а её решение проходит в три этапа: определение момента возникновения (признания) расходов; отнесение расходов к отчётным периодам, за который исчисляется финансовый результат, оценка расходов.

Использованные источники:

1 Гражданский кодекс Российской Федерации (часть первая) [Электронный ресурс].: федер. закон от 30.11.1994 № 51-ФЗ // КонсультантПлюс : справочная правовая система / разработ. НПО «Вычисл. математика и информатика». – Москва : Консультант Плюс, 1997-2020. – Режим доступа : <http://www.consultant.ru>. – 24.12.2020.

2 Налоговый кодекс Российской Федерации (часть вторая) [Электронный ресурс].: федер. закон от 05.08.2000 № 117-ФЗ // КонсультантПлюс : справочная правовая система / разработ. НПО «Вычисл. математика и информатика». – Москва : Консультант Плюс, 1997-2020. – Режим доступа : <http://www.consultant.ru>. – 24.12.2020.

3 О бухгалтерском учете [Электронный ресурс].: федер. закон от 06.12.2011 № 402-ФЗ // КонсультантПлюс : справочная правовая система / разработ. НПО «Вычисл. математика и информатика». – Москва : Консультант Плюс, 1997-2020. – Режим доступа : <http://www.consultant.ru>. – 24.12.2020.

4 Расходы организации [Электронный ресурс]. : положение по бухгалтерскому учету ПБУ 10/99 : приказ Минфина России от 06.05.1999 № 33н // КонсультантПлюс : справочная правовая система / разработ. НПО «Вычисл. математика и информатика». – Москва : Консультант Плюс, 1997-2020. – Режим доступа : <http://www.consultant.ru>. – 24.12.2020.

5 Об утверждении Положения по ведению бухгалтерского учёта и бухгалтерской отчётности в Российской Федерации [Электронный ресурс]: приказ Минфина России от 29.07.1998 № 34н // КонсультантПлюс : справочная правовая система / разработ. НПО «Вычисл. математика и информатика». – Москва : Консультант Плюс, 1997-2020. – Режим доступа : <http://www.consultant.ru>. – 24.12.2020.

*Куликов И.А.
студент магистратуры
Оренбургский государственный университет*

МЕТОДИКА АНАЛИЗА КРЕДИТОРСКОЙ ЗАДОЛЖЕННОСТИ ОРГАНИЗАЦИИ

Аннотация: В статье рассмотрены различные авторские методики анализа кредиторской задолженности и на их основе предложена собственная, более универсальная и комплексная методика

Ключевые слова: кредиторская задолженность, комплексная методика, экономический анализ

*Kulikov I. A.
master student
Orenburg State University*

ANALYSIS METHODOLOGY OF THE ORGANIZATION'S CREDITS DEBT

Abstract: The article discusses various author's methods of analyzing accounts payable and, on their basis, proposes his own, more universal and complex method.

Key words: accounts payable, complex methodology, economic analysis

В условиях современной рыночной экономики любая хозяйственная деятельность связана с определённой долей неопределённости и риска, что, в свою очередь, требует объективной оценки финансового состояния и платёжеспособности организации.

Кредиторская задолженность, её объём и качество, оказывает существенное влияние на финансовое положение хозяйствующего субъекта. Важность анализа кредиторской задолженности обусловлена тем, что, составляя значительную долю текущих пассивов организации, её изменение значительно сказывается на динамике показателей платёжеспособности и ликвидности.

Значительный и неконтролируемый рост кредиторской задолженности приводит к утрате контроля над величиной текущих обязательств, и в отдельных случаях – к банкротству организации, поэтому проблеме анализа и управления кредиторской задолженности во всех организациях должно уделяться повышенное внимание.

Эффективность управления обязательствами организации во многом зависит от знаний методики анализа и умений их использования, однако на

данный момент комплексная методика оценки данного показателя отсутствует, из чего вытекает потребность в создании универсальной и несложной методики анализа кредиторской задолженности.

В настоящее время существует большое количество авторских методик проведения анализа кредиторской задолженности, в число которых входят горизонтальный, вертикальный, коэффициентный, и факторный методы.

Горизонтальный метод анализа кредиторской задолженности, предлагаемый Г. В. Савицкой, заключается в сопоставлении показателей соответствующих статей отчётности за различные периоды времени. Горизонтальный анализ способен определить существенные изменения в деятельности организации, а также выявить отклонения, происходящие в её финансовом состоянии [5].

Анализ состава, структуры и динамики кредиторской задолженности следует оформить в виде таблицы. Особое внимание следует обратить на увеличение удельного веса краткосрочной кредиторской задолженности, так как краткосрочная кредиторская задолженность связана с большим риском, чем долгосрочная кредиторская задолженность, поскольку требует раннего погашения [3].

Вертикальный метод анализа используется при оценке качества долговых обязательств, с его помощью определяется удельный вес отдельного вида задолженности в её общем объёме для последующего анализа изменений в структуре кредиторской задолженности [2].

Качество кредиторской задолженности может быть оценено также удельным весом в ней расчётов по вексям. Доля кредиторской задолженности, обеспеченная выданными вексями, в общей её сумме показывает ту часть долговых обязательств, несвоевременное погашение которых приведёт к протесту векселей, выданных организацией, а следовательно, к дополнительным расходам и утрате деловой репутации.

Также применяется коэффициентный метод оценки движения долговых обязательств. Рядом таких учёных, как Л. И. Маслова и О. В. Ларионова, предлагаются следующие коэффициенты, которые рассчитываются по следующим формулам [4]:

$$K_1 = \frac{\text{Возникшая кредиторская задолженность}}{\text{Остаток кредиторской задолженности на конец периода}} * 100\%$$

$$K_2 = \frac{\text{Сумма непогашенной кредиторской задолженности}}{\text{Сумма КЗ на начало периода + вновь возникшая КЗ}} * 100\%$$

Первый коэффициент называется – коэффициент возникновения задолженности (K_1), и характеризует по мнению авторов – удельный вес вновь возникшей задолженности по отношению к её остатку на конец

периода. Практика расчёта данного коэффициента демонстрирует, что если $K_1 < 100\%$, то это отрицательно характеризует контроль предприятия за движением задолженности.

Второй коэффициент (K_2) – характеризует процент погашения кредиторской задолженности за отчётный период.

Также одним из наиболее важных коэффициентов, используемым в любой авторской методике анализа кредиторской задолженности, является коэффициент оборачиваемости кредиторской задолженности, который характеризует скорость погашения организацией своей задолженности перед кредиторами. Данный коэффициент отражает число погашений хозяйствующим субъектом за период (как правило, год) средней величины своей кредиторской задолженности и определяется по формуле [1]:

$$K_{кз} = \frac{\text{Выручка}}{КЗ_{ср}},$$

где $K_{кз}$ – коэффициент оборачиваемости кредиторской задолженности;
 $КЗ_{ср}$ – среднегодовая кредиторская задолженность.

Исследовав методы анализа кредиторской задолженности можно сделать вывод о том, что большинство авторских методик используют традиционные методы, а не факторный метод анализа, который более прогрессивен и позволяет рассчитать факторы, влияющие на изменение показателей (коэффициентов) оборачиваемости кредиторской задолженности.

Перед проведением факторного анализа необходимо определиться с типом модели и методом его проведения. В случае с кредиторской задолженностью организации – это метод цепных подстановок и аддитивная модель.

Следующим шагом является определение результативного фактора, в качестве которого выступает общий объём кредиторской задолженности организации, и факторов, оказывающих влияние.

В целях упрощения расчётов в модели возможно использование не всех факторов, влияющих на результативный показатель, а только тех, которые обладают достаточным уровнем существенности.

Таким образом, факторная модель кредиторской задолженности в общем виде будет иметь следующую формулу:

$$V = a + b + c$$

где V – общий объём кредиторской задолженности;
 a – первый вид кредиторской задолженности;

b – второй вид кредиторской задолженности;

c – третий вид кредиторской задолженности.

Сперва рассчитывается показатель с использованием данных за базисный год по формуле:

$$V_0 = a_0 + b_0 + c_0$$

Далее рассчитывается система условных показателей по формулам:

$$V_{\text{усл1}} = a_1 + b_0 + c_0$$

$$V_{\text{усл2}} = a_1 + b_1 + c_0$$

Затем рассчитывается показатель с использованием данных за отчётный год по формуле:

$$V_1 = a_1 + b_1 + c_1$$

После, путём последовательного вычитания полученных показателей, находится изменение общего объёма кредиторской задолженности организации за счёт отдельных факторов по формулам:

$$\Delta a = V_{\text{усл1}} - V_0$$

$$\Delta b = V_{\text{усл2}} - V_{\text{усл1}}$$

$$\Delta c = V_1 - V_{\text{усл2}}$$

В конце рассчитывается общее изменение всего объёма кредиторской задолженности за счёт всех учтённых в модели факторов по формуле:

$$\Delta V = V_1 - V_0 = \Delta a + \Delta b + \Delta c$$

Полученные результаты позволят выявить тот вид кредиторской задолженности, который больше всего повлиял на её увеличение или уменьшение.

Подводя итоги, кредиторская задолженность является неотъемлемой частью денежных отношений и играет значительную роль в деятельности любой организации. Величина задолженности может существенным образом влиять на формирование таких показателей экономической деятельности хозяйствующего субъекта, как ликвидность и платёжеспособность.

Таким образом, залогом дальнейшего функционирования организации и её устойчивого финансового состояния является удержание объёмов кредиторской задолженности в рамках допустимых значений, чему способствует рациональная и комплексная методика анализа кредиторской задолженности, позволяющая оптимизировать процесс проведения оценки, снизив временные затраты и повысив качественные параметры.

Использованные источники:

- 1 Валинуров, Т. Р. Специфика оценки дебиторской и кредиторской задолженностей предприятия / Т. Р. Валинуров, Т. В. Трофимова // Финансовая аналитика: проблемы и решения. – 2014. – № 2. – с. 20-30.
- 2 Елютина, Ю. П. Методика экономического анализа дебиторской и кредиторской задолженности предприятий / Ю. П. Елютина // Moretn Science. – 2019. – № 9-2. – с. 41-44.
- 3 Жданов, А. Ю. Методика оценки и анализа кредиторской и дебиторской задолженностей / А. Ю. Жданов, Л. В. Зубенко, Е. В. Иода // Социально-экономические явления и процессы. – 2018. – № 13 (1). – с. 92-96.
- 4 Маслова, Л. И. Экономический анализ : учебное пособие и практикум / Л. И. Маслова, О. В. Ларионова, И. М. Перминова. – Екатеринбург : Ажур, 2018. – 258 с. – ISBN 978-5-91256-413-0.
- 5 Савицкая, Г. В. Комплексный анализ хозяйственной деятельности предприятия : учебник / Г.В. Савицкая. – 7-е изд., перераб. и доп. – Москва : ИНФРА-М, 2020. – 608 с. – ISBN 978-5-16-011214-5.

*Лагода М.Ю.
студент магистратуры
научный руководитель: Туякова З.С., д.э.н.
профессор
Оренбургский государственный университет*

АНАЛИЗ ЭФФЕКТИВНОСТИ ИСПОЛЬЗОВАНИЯ МАТЕРИАЛЬНЫХ РЕСУРСОВ

Аннотация: В статье рассмотрена актуальность рационального использования материальных затрат на предприятии, изучена проблема применяемой терминологии в учете материальных затрат, проведен анализ эффективности использования материальных ресурсов на примере автотранспортного предприятия ООО «Оренбурггазтранс». Сформулированы основные проблемы рационального использования материальных ресурсов и даны рекомендации по совершенствованию.

Ключевые слова: эффективность, анализ, материальные ресурсы, показатели, бухгалтерский учёт.

*Lagoda M. Yu.
graduate student
Scientific adviser: Tuyakova Z.S., Doctor of Economics
professor
Orenburg State University*

ANALYSIS OF THE EFFICIENCY OF THE USE OF MATERIAL RESOURCES

Abstract: The article examines the relevance of the rational use of material costs at the enterprise, studies the problem of the terminology used in accounting for material costs, analyzes the efficiency of the use of material resources on the example of the motor transport enterprise LLC "Orenburggaztrans". The main problems of rational use of material resources are formulated and recommendations for improvement are given.

Key words: efficiency, analysis, material resources, indicators, accounting.

Материальные запасы, являясь предметами труда, обеспечивают вместе со средствами труда и рабочей силой производственный процесс предприятия, в котором они используются однократно. Себестоимость их полностью передается на вновь созданный продукт.

В условиях рыночной экономики актуальной становится тема учета, анализа и контроля материальных затрат на производство продукции

(товаров, работ, услуг). В компаниях проблема эффективности и результативности использования природных ресурсов, особенно в стоимости услуг всегда становится основным моментом для пользователей финансового отчета.

Сохранность и рациональное использование материалов обусловлено тем, что материальные ресурсы – часть национального баланса страны. Добыча обходится дорого, а запасы полезных ископаемых невосполнимы. Особое внимание необходимо уделить снижению материальных затрат путем принятия новых решений, внедрения новых технологий, норм переработки[1].

Производство любого вида продукции (работ, услуг) связано с использованием материальных ресурсов. Материальные ресурсы определенного ассортимента и качества являются основой и необходимым условием выполнения программы выпуска и реализации продукции (работ, услуг), снижения себестоимости. Комплексное использование ресурсов, их рациональный расход, применение более дешевых и эффективных материалов является важнейшим направлением увеличения выпуска продукции и улучшения финансового состояния.

Обновление ассортимента, расширение производственных возможностей обуславливает рост потребности в материальных ресурсах. Хозяйствующие субъекты потребляют огромное количество материальных ресурсов, различных по видам, маркам, сортам, размерам[3].

Номенклатура и ассортимент потребляемых материальных ресурсов зависят от номенклатуры и сложности производимой продукции (работ, услуг).

Номенклатура материалов дает возможность правильно систематизировать и группировать расчеты потребности в одних и тех же материалах.

Все затраты, образующие себестоимость на автотранспортных предприятиях, группируются по следующим элементам, которые представлены на рисунке 1.



Рисунок 1 – Затраты производства

В настоящее время дискуссионными остаются проблемы применяемой терминологии в учете материальных затрат. Знание об их

существовании, а также разработка предложений по их устранению актуальны не только для развития теории, но и практической деятельности. Перечень основных понятий материальных затрат представлен в таблице 1.

Таблица 1 – Подходы к определению понятия «материальные затраты»

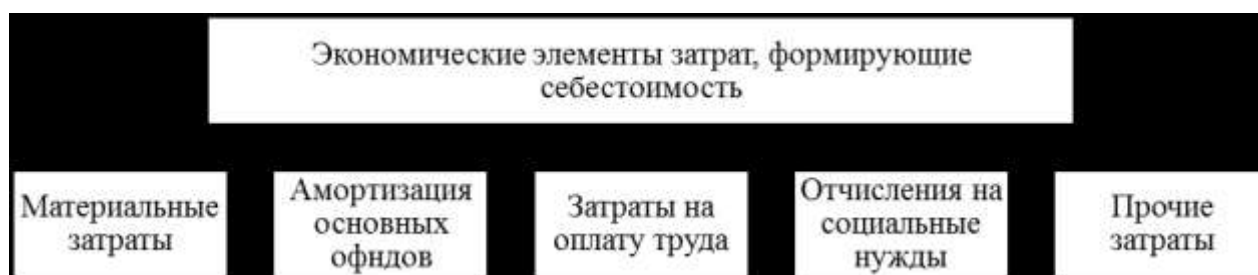
Автор или источник	Понятие
1	2
В. Г. Гетьман	Стоимость материальных ресурсов, приобретенных со стороны и используемых в процессе изготовления продукции как ее основа или необходимый компонент
Петрусенко В.П.	Материальные затраты - это часть средств, которые тратят на производство услуг и товаров
Чая В.Т.	Материальные затраты - это вид расходов организации, которые используются для услуг производства и поддержания возможности производить товары (например, электричество, вода и др.).
Куценко О.А.	Материальные затраты (direct materials costs) - это стоимостное выражение затрат материальных ресурсов на производство и реализацию продукции в организации, определяемое в расчетах ее себестоимости
Кондраков Н.П.	Затраты определяются величиной использованных ресурсов, которая должна быть представлена в денежном выражении для обеспечения соизмерения различных ресурсов
Пункт 2 ПБУ 10/99 Расходы организации	Расходами признается уменьшение экономических выгод в результате выбытия активов и возникновения обязательств, которые приводят к уменьшению капитала организации, за исключением уменьшения вкладов по решению собственников имущества
Налоговый Кодекс РФ	Материальные расходы - вид расходов, связанных с производством и реализацией, определенный в ст. 254 НК

Обобщая вышеприведенные понятия, можно сказать, что материальные расходы – это материально-производственные запасы, которые используются при производстве продукции, выполнении работ и оказании услуг.

Источниками информации анализа обеспеченности хозяйствующих субъектов материальными ресурсами служат данные:

- бизнес-плана;
- данные оперативно-технического и бухгалтерского учета;
- сведения аналитического бухгалтерского учета о поступлении, расходе и остатках материальных ресурсов;
- форма № 5-з «Сведения о затратах на производство и реализацию продукции (работ, услуг)»[2].

Оценка эффективности использования материальных ресурсов является неотъемлемой частью анализа финансового состояния предприятия. осуществляется при помощи различных показателей. Чтобы

произвести любой вид продукции, работ, услуг, предприятию необходимо использовать материальные ресурсы. Основой и необходимым условием выполнения плана производства и сбыта продукции (работ, услуг), а также снижения себестоимости выступают материальные ресурсы. Рациональный расход, применение наиболее дешёвых и эффективных материальных ресурсов, их комплексное использование и качественный анализ эффективности становятся всё более важным направлением увеличения выпуска продукции (объёма оказываемых услуг, выполняемых работ) и улучшения финансового состояния[4].

Цель анализа материальных ресурсов состоит в повышении эффективности производства за счет рационального использования и отражения в учёте ресурсов.

В настоящее время широко используются показатели, для расчёта которых применяется сумма материальных затрат, а не материальных ресурсов. Это является более рациональным подходом, так как в процессе потребления происходит трансформация материальных ресурсов в материальные затраты, то есть стоимость израсходованных материальных ресурсов выражается материальными затратами, а показателями – уровень их расходования в производстве, которые исчисляются исходя из суммы материальных затрат[5].

Проведём анализ эффективности использования материальных ресурсов на примере автотранспортного предприятия ООО «Оренбурггазтранс».

Результаты расчетов по предприятию ООО «Оренбурггазтранс» представим в таблице 1.

Таблица 1 – Анализ эффективности использования материальных ресурсов ООО «Оренбурггазтранс» за 2018-2020 гг.

Показатели	Года			Абсолютное отклонение (+;–)		Темп роста, %	
	2018 г.	2019 г.	2020 г.	2020 г. от 2018 г.	2020 г. от 2019 г.	2020 г. к 2018 г.	2020 г. к 2019 г.
Выручка, тыс. р.	434144	457252	545172	111028	87920	125,6	119,2
Материальные затраты, тыс. р.	9755	10690	11201	1446	511	114,8	104,8
Материалоотдача, р./р.	44,5	42,8	48,7	4,2	5,9	109,4	113,8
Материалоемкость, р./р.	2,2	2,3	2,05	-0,15	-0,25	93,2	89,1
Полная себестоимость оказанных услуг, тыс. р.	461296	481505	542251	80955	60746	117,5	112,6
Удельный вес материальных затрат в себестоимости оказанных услуг	2,1	2,2	2,1	0	-0,1	100	95,5

Таким образом, из таблицы 1 видно, что материалоемкость услуг в 2020 г. уменьшилась по сравнению с 2018 г. Темп роста материалоемкости в 2020 году к 2019 г. и 2018 г. соответственно составил 89,1 и 93,2 %. Этот факт расценивается как положительный, так как он означает, что сумма материальных затрат на производство увеличилась менее быстрыми темпами, чем увеличивался объем производства.

Показатели эффективности использования материальных ресурсов ООО «Оренбурггазтранс» представлены на рисунке 1.



Рисунок 1 – Показатели эффективности использования материальных ресурсов ООО «Оренбурггазтранс»

Материалоотдача в 2020 году увеличилась по отношению к 2019 году на 5,9 р./р. Темп роста в 2020 году составил 113,9 %. Это говорит об эффективности использования материалов и сырья на предприятии.

Удельный вес материальных затрат в себестоимости оказываемых услуг в 2018 году составил 2,1 %, в 2019 году – 2,2 %, в 2020 году – 2,1 %. Темп роста в 2020 году составил 95,5 %.

По результатам анализа использования материальных ресурсов на предприятии ООО «Оренбурггазтранс» следует выработать тактическую и стратегическую политику в области ресурсосбережения, направленную на повышение эффективности использования материальных ресурсов на предприятии.

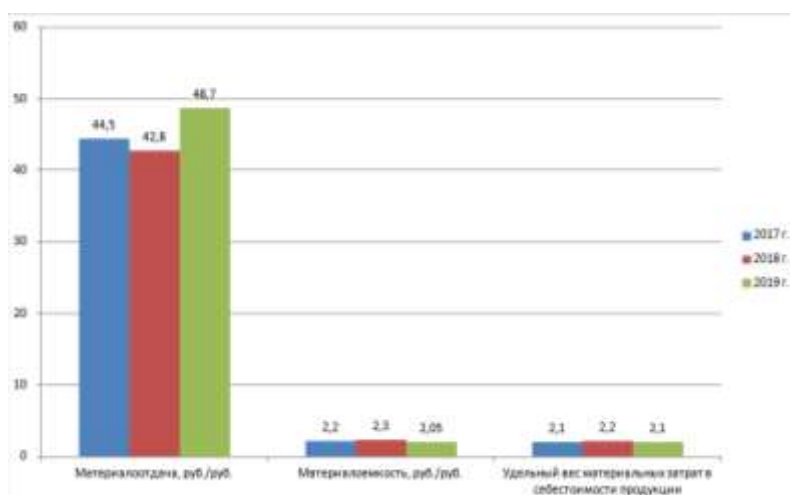
Таким образом, для того, чтобы уменьшить расход сырья на оказание транспортных услуг на предприятии ООО «Оренбурггазтранс» можно предложить следующие мероприятия:

- заготовки оптимального по соотношению «цена-качество» сырья (первому, как правило, соответствуют отечественные производители, второму – иностранные);

- освобождение предприятия от излишнего оборудования, машин и других основных средств или сдача их в аренду;
- рациональная их реализация на сторону;
- совершенствования техники и технологии производства;
- сокращения до минимума отходов от производства;
- уменьшение потерь сырья во время хранения и перевозки;
- проведение анализа использования материальных ресурсов для повышения качества формирования информации, необходимой для эффективного управления ресурсами

Использованные источники:

1. Туякова З.С., Развитие методологии учёта обесценения материально-производственных запасов в современном бухгалтерском учёте [Электронный ресурс]: Бухгалтерский учёт в издательстве и полиграфии. - 2008. - №2(110), 2008. - с. 8-12 - URL: <https://www.elibrary.ru/item.asp?id=9596457> (дата обращения: 10.12.2020).
2. Егорова Л.Г., Туякова З.С., Характеристика и классификация материалов, их использование на различных этапах учётного процесса [Электронный ресурс]: Интеллект. Инновации. Инвестиции. - 2016. - №9, 2016. - с. 38-44 - URL: <https://www.elibrary.ru/item.asp?id=28846528> (дата обращения: 11.12.2020).
3. Куликова Л.И., Влияние оценок материально-производственных запасов на финансовое положение организации [Электронный ресурс]: Проблемы и перспективы развития учетно-аналитической и контрольной системы в условиях глобализации экономических процессов. - 2015. - Оренбург: 2015. - с 72-76 - URL: <https://www.elibrary.ru/item.asp?id=23003022> (дата обращения: 12.12.2020).
4. Туякова З.С., Кожина Л.А., Особенности учета и анализа использования материалов при производстве продукции [Электронный ресурс]: Реструктуризация экономики России и промышленная политика. Труды научно-практической конференции с зарубежным участием. Под редакцией А.В. Бабкина. - 2015. - Санкт-Петербург, 2015. - с. 319-326 - URL: <https://www.elibrary.ru/item.asp?id=23391548> (дата обращения: 13.12.2020).
5. Садовников А.А., Садовников К.А., Экономический анализ эффективности использования материальных ресурсов на предприятии [Электронный ресурс]: Машиностроитель. – 2017. – Герсамия р.р., № 11, 2017. - с. 10-12 - URL: <https://www.elibrary.ru/item.asp?id=11918426> (дата обращения: 13.12.2020).

*Лепс Я.С.
студент
Романова Л.М., к.т.н.
доцент
СГУ
г. Сочи*

СОВЕРШЕНСТВОВАНИЕ ТЕХНОЛОГИЙ В ЭКСКУРСИОННОЙ ДЕЯТЕЛЬНОСТИ

Аннотация: В современном мире просто невозможно представить жизнь без информационных технологий. В нашу жизнь они вошли прочно, технологий используются во всех сферах человеческой деятельности. Не стала исключением и экскурсионная деятельность: внедрение различных инновационных технологий и интегрирование их с уже ставшей привычной экскурсионной деятельностью носят необратимый характер. Экскурсионный туризм - один из основных видов туризма, который на сегодняшний день не теряет своей востребованности и развивается во многих странах мира, а экскурсия является одной из популярных туристических услуг. В данной статье рассмотрены инновационные формы экскурсионной деятельности, приведена классификация инновационных технологий.

Ключевые слова: инновации, инновационные технологии в туризме, туризм, экскурсионная деятельность, экскурсия.

*Leps Y.S.
student
Romanova L.M.
Associate Professor
SSU
Russia, Sochi*

IMPROVING TECHNOLOGIES IN EXCURSION ACTIVITIES

Abstract: In the modern world, it is simply impossible to imagine life without information technology. They entered our life firmly, technologies are used in all spheres of human activity. Excursion activity was no exception: the introduction of various innovative technologies and their integration with the already familiar excursion activity are irreversible. Excursion tourism is one of the main types of tourism, which today does not lose its relevance and is developing in many countries of the world, and the excursion is one of the popular

tourist services. This article discusses innovative forms of excursion activity, provides a classification of innovative technologies.

Keywords: innovations, innovative technologies in tourism, tourism, excursion activity, excursion.

Туризм – динамическая система, которой необходимо постоянное изменение, внедрение новых элементов, способных повысить рентабельность услуг предприятий данной сферы. Для каждого из видов туризма разрабатываются свои нововведения, отражающие его специфику. Не остается в стороне и экскурсионный туризм, который не теряет своей значимости и востребованности, а экскурсии остаются одной из самых популярных туристских услуг.

Инновации в экскурсионной деятельности способствуют созданию конкурентной среды, продвижению услуг на туристском рынке. Создавая новый экскурсионный продукт, необходимо учитывать спрос потребителей и делать акцент на клиентоориентированность и дифференциацию обслуживания.

Инновации в экскурсионной деятельности дают преимущество одной экскурсии над другой, что способствует успешному продвижению на рынке. Новшества всегда интересовали людей, правильно выбранная целевая аудитория имеет важную роль. В экскурсионной деятельности инновации представляют собой маршруты и экскурсионные разработки, новые как по тематике, так и по качеству. При этом инновационной может быть не только абсолютно новая экскурсия, но и отдельные ее элементы.

Инновации в проведении экскурсий условно разделяют на два основных направления: – с использованием новых форм и методов; – с использованием ИТ-технологий; Уровень развития экскурсионного туризма сегодня совершенствуется. Следует сказать о том, что экскурсии прошли долгий путь эволюции, от примитивных рассказов экскурсоводов, до необычайно театрализованных 3D экскурсий. Российские программисты сделали возможным путешествие по мировым памятникам культуры. В современных условиях компьютеризации 3D экскурсии стали возможны не выходя из дома и сидя у компьютера. Уникальная программа обеспечивает эффект полного погружения при минимальной загрузке компьютера. Чтобы стать виртуальным туристом, достаточно скачать из Интернета небольшую программу. Пользователь может ходить, взлетать с любого места, приземляться, смотреть. Графика виртуальных объектов – на уровне лучших современных компьютерных игр. Разработчики создают модели по точным чертежам и множеству фотографий. Например, при создании проекта «Тадж-Махал» были использованы пять тысяч изображений. Сейчас 3D экскурсии применяются множеством туристических фирм, это путешествие по ресторанам, гостиничным комплексам и т. д. Далее, остановимся на некоторых примерах,

подтверждающих идею значимости инноваций в развитии и совершенствования современного экскурсионного туризма.

В испанском городе Кордова появились специализированные автомобили, которые «рассказывают» о местных достопримечательностях. Транспортное средство работает при поддержке GPS. Экскурсант получает не только звуковой комментарий, но и наглядное подтверждение услышанному, которое отображается на специальном мониторе. Компьютеризированная система работает с картой памяти, на которой записана информация о 150 наиболее посещаемых туристами местах. Система является многоязычной.

Технические инновации в настоящее время включают в себя радио- и аудиогиды, GPS-экскурсоводы, а также новшества, позволяющие самостоятельно изучать экскурсионные объекты: QR-код, мобильные приложения. Здесь необходимо отметить уже достаточно широкое использование QR-кодов в экскурсионной деятельности. Зачастую их размещают на исторических и культурных объектах, произведениях искусства, а также рядом с памятниками природы, благодаря чему экскурсант может дополнить рассказ экскурсовода или вовсе заменить.

Одним из интересных нововведений, которое можно отнести к экскурсионной деятельности, является внедрение аудиогидов для пассажиров, пользующихся пригородными электропоездами. Проект носит название «Говорящие экспрессы», в рамках которого реализуется аудиосопровождение рассказами об интересных местах.

Использование геоинформационных технологий в экскурсионной деятельности также носит инновационный характер. ГИС-технологии (ГИС – геоинформационная система) могут быть использованы для создания туристских маршрутов для различных видов экскурсий, так как есть возможность получения информации о режиме работы достопримечательностей и информацию о различных мероприятиях. Геоинформационные технологии – одна из перспективных систем, используемая для решения задач поиска, мониторинга, анализа информации, моделирования и формирования туристского и экскурсионного продукта в частности.

Инновации в сфере туризма иногда возникают совершенно неожиданно и даже непредсказуемо под влиянием событий в обществе. Поэтому изучение инновационных процессов, причин появления новшеств, разработка методов их внедрения представляет значительный и практический научный интерес. Подводя итоги вышеизложенному, следует заключить, что инновационная деятельность в сфере экскурсионного туризма имеет важное значение, она направлена на создание нового или изменение существующего продукта, на совершенствование транспортных, гостиничных и других услуг, освоение новых рынков, внедрение передовых

информационных и телекоммуникационных технологий и современных форм организационно – управленческой деятельности.

Использованные источники:

1. Яговец В.С. Особенности методики и техники проведения экскурсий в активных видах туризма // Учёные записки (АГАКИ). 2018. №3 (17). URL: <https://cyberleninka.ru/article/n/osobennosti-metodiki-i-tehniki-provedeniya-ekskursiy-v-aktivnyh-vidah-turizma> (дата обращения: 25.12.2020).
2. Ухтинская Мария Владимировна Туристско-экскурсионная деятельность в организации досуга подростков // Вестник СПбГИК. 2020. №3. URL: <https://cyberleninka.ru/article/n/turistsko-ekskursionnaya-deyatelnost-v-organizatsii-dosuga-podrostkov> (дата обращения: 25.12.2020).
3. Рыжикова Юлия Александровна Технология организации образовательной экскурсии // Вестник ЮУрГГПУ. 2017. №2. URL: <https://cyberleninka.ru/article/n/tehnologiya-organizatsii-obrazovatelnoy-ekskursii> (дата обращения: 25.12.2020).
4. Ватолкина Н. Ш. Особенности управления качеством туристско-экскурсионных услуг // Вестник МГУ. 2019. №3. URL: <https://cyberleninka.ru/article/n/osobennosti-upravleniya-kachestvom-turistsko-ekskursionnyh-uslug> (дата обращения: 25.12.2020).
5. Зайцева Олеся Андреевна Стандартизация услуг и роль добровольной сертификации в развитии туристской отрасли России // Известия ДГПУ. Естественные и точные науки. 2018. №1. URL: <https://cyberleninka.ru/article/n/standartizatsiya-uslug-i-rol-dobrovolnoy-sertifikatsii-v-razvitii-turistskoj-otrasli-rossii> (дата обращения: 25.12.2020).

Ли А.А.
студент магистратуры
ОГУ
РФ, г. Оренбург
научный руководитель: Гребнев Г.Д., канд. экон. наук
доцент
ОГУ
РФ, г. Оренбург

АНАЛИЗ РОЗНИЧНОГО ТОВАРООБОРОТА ТОРГОВОЙ ОРГАНИЗАЦИИ НА ПРИМЕРЕ ООО «АЛЕКСАНДРИТ»

Аннотация: В статье проведён анализ товарооборота торговой организации.

Ключевые слова: товароборот, розничный товароборот, торговля.

Lee A.A.
master's student
at OSU
Russian Federation, Orenburg
Scientific adviser: Grebnev G.D., candidate of Economic Sciences
Associate Professor
of OSU
Russian Federation, Orenburg

ANALYSIS OF RETAIL TURNOVER OF A TRADE ORGANIZATION ON THE EXAMPLE OF LLC «ALEXANDRIT»

Abstract: The article analyzes the trade organization's turnover.

Key words: turnover, retail turnover, trade.

В настоящее время главной целью торговых предприятий должно быть получение максимальной прибыли, при этом товароборот выступает как важнейшее и необходимое условие, без которого не может быть достигнута эта цель. Поскольку торговое предприятие получает определенную сумму дохода с каждого рубля реализуемых товаров, то задача максимизации прибыли вызывает необходимость постоянного увеличения объема товарооборота как основного фактора роста доходов и прибыли, относительного снижения расходов на реализацию и расходов на оплату труда. В сфере розничной торговли показатель товарооборота является важнейшей характеристикой деятельности предприятия.

Розничный товарооборот выступает как один из показателей, определяющих мощьность торгового предприятия, так как по его величине можно судить об объеме деятельности предприятия. Розничный товарооборот характеризует эффективность использования ресурсов предприятия и общей суммы затрат на реализацию товаров. Поскольку товарооборот является экономическим понятием, отражающим важнейший конечный результат хозяйственной деятельности торгового предприятия, то его сопоставление с объемом затраченных ресурсов (трудовых, материальных, финансовых) дает представление об эффективности их использования, так как в обобщенном виде показатель эффективности есть соотношение результата и затрат.

На начальном этапе анализа розничного товарооборота изучается его динамика. Анализ динамики розничного товарооборота осуществляется за ряд лет, в нашем случае взяты года с 2017 по 2019 год с использованием таких показателей как темп роста и темп прироста.

В таблице 1 проведем анализ динамики общего объема товарооборота в ООО «Александрит» за период 2017-2019 гг.

Таблица 1 – Анализ динамики общего объема товарооборота в ООО «Александрит» за период 2017-2019 гг.

Год	Фактический розничный товарооборот, тыс. р.	Темп роста, %	Темп прироста, %
2017	220112	-	-
2018	365350	166	66
2019	450934	123	23

Данные таблицы 1 показывают, что в 2019 году по сравнению с 2018 годом наблюдается увеличение товарооборота на 66%. Темп роста составил 123% по сравнению с 2018 годом, объем товарооборота увеличился на 23% и в 2019 году составил 450934 тыс. р., что на 85584 тыс. р. больше чем в 2018 году.

В таблице 2 проведем анализ динамики общего объема товарооборота в ООО «Александрит» по кварталам за 2018-2019 гг.

Таблица 2 – Анализ динамики общего объема товарооборота в ООО «Александрит» по кварталам за 2018-2019 гг.

Квартал	2018 г.		2019 г.		Отклонение, тыс. р. (+/-)	Темп изменения, %
	сумма, тыс. р.	Уд. вес, %	сумма, тыс. р.	Уд. вес, %		
I	74632	20,4	95733	21,2	+21101	128,3
II	87690	24	106150	23,5	+18460	121,5
III	99423	27,2	115033	25,5	+15610	115,7
IV	103605	28,4	134018	29,7	+30413	129,3
Итого	365350	100	450934	100	+85584	123,4

Проанализировав данные таблицы 2, можно сделать вывод, что наибольший удельный вес в годовом товарообороте 2018 года занимает оборот четвертого квартала – свыше 28%, а наименьший удельный вес наблюдается в первом квартале – 20,4%. В 2019 году структура товарооборота по кварталам более равномерна. Так же, как и в 2018 году наименьший удельный вес наблюдается в первом квартале – 21,2%, а наибольший удельный вес в четвертом квартале – 29,7%. Можно также отметить, что в 2019 году объем товарооборота увеличился во всех четырех кварталах, как и в 2018 году.

В таблице 3 проведем анализ динамики розничного товарооборота в ООО «Александрит» за период 2017-2019 гг. по различным группам товаров.

Таблица 3 – Динамика розничного товарооборота в ООО «Александрит» за период 2017-2019 гг. по различным группам товаров

Тип товара	2017 г., тыс. р.	2018 г., тыс. р.	2019 г., тыс. р.	Абсолютное отклонение, тыс. р.		Темп прироста, %	
				2019 г. к 2017 г.	2019 г. к 2018 г.	2019 г. к 2017 г.	2019 г. к 2018 г.
Браслет	2484,3	2695,6	3003,5	519,2	307,9	20,9	11,4
Брошь	44,8	69,4	192,3	147,5	122,9	329,2	177,1
Булавка	54,3	68,1	68,2	13,8	0,1	25,4	0,1
Крест	1069,3	1356,8	1166,8	97,5	-190	9,1	-14
Кольцо	13589,4	16283,4	14854,3	1264,9	-1429,1	9,3	-8,8
Подвеска	2854,9	3635,1	3228,2	373,3	-406,9	13,1	-11,2
Серьги	12087,8	17037,9	15449,2	3361,4	-1588,7	27,8	-9,3
Цепь	6299,9	6449,5	6703,8	403,9	254,3	6,4	3,9
Итого:	38484,7	47595,8	44666,2	6181,5	-2929,6	16,1	-6,2

Данную динамику можно увидеть на диаграмме (рисунок 1).



Рисунок 1 – Динамика розничного товарооборота в ООО «Александрит» за период 2017-2019 гг. по различным группам товаров.

Анализируя данные таблицы 3, можно сделать вывод о том, что наибольшая реализация товаров произошла в 2018 году, она составила 47595,8 тыс. р., что на 2929,6 тыс. р. или на 16,1% больше реализации товаров 2019 года. По товарной группе «Серьги» произошла наибольшая реализация которая составила 17037,9 тыс. р., это больше на 4950,1 тыс. р. или на 40,9% чем в 2017 году и больше на 1588,7 тыс. р. или на 10,3% чем в 2019 году.

Проведем анализ структуры розничного товарооборота в ООО «Александрит» за период 2017-2019 гг. по различным группам товаров (таблица 4).

Таблица 4 – Структура розничного товарооборота в ООО «Александрит» за период 2017-2019 гг. по различным группам товаров

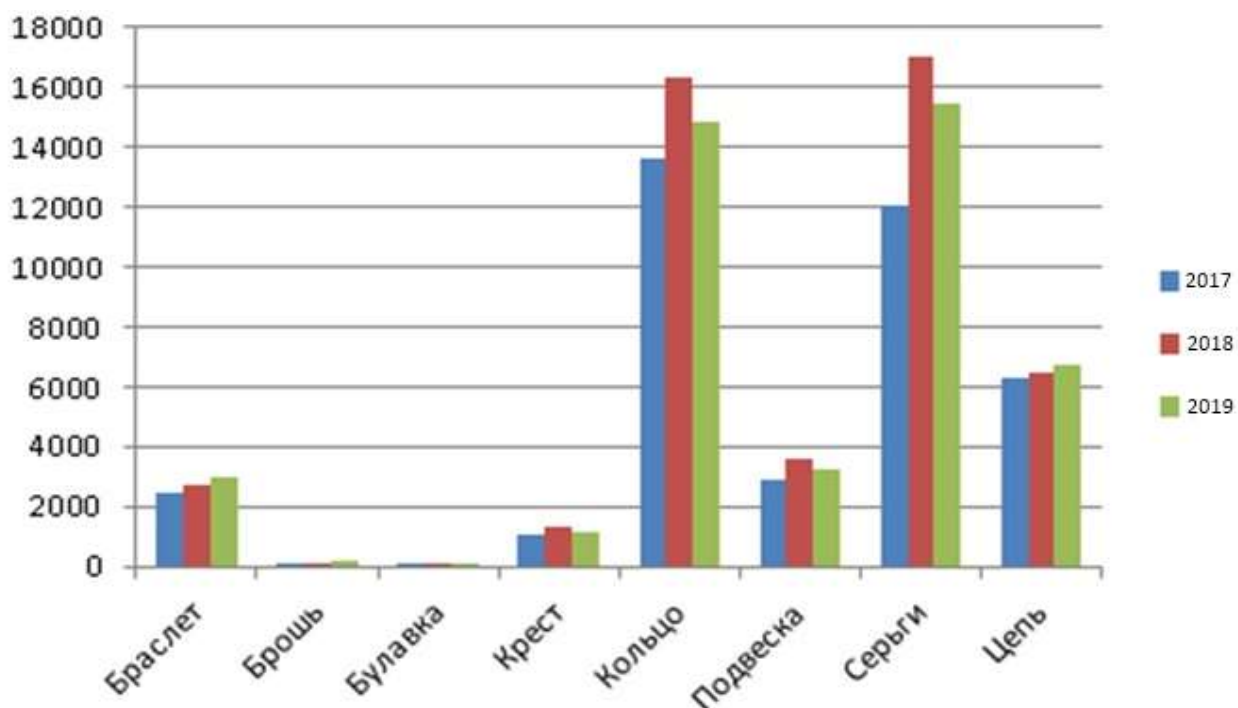
Вид товара	2017 г.		2018 г.		2019 г.		Изменение структуры, %	
	Тыс. р.	Доля, %	Тыс. р.	Доля, %	Тыс. р.	Доля, %	2019 г. к 2017 г.	2019 г. к 2018 г.
Браслет	2484,3	6,5	2695,6	5,7	3003,5	6,7	0,2	1
Брошь	44,8	0,1	69,4	0,1	192,3	0,4	0,3	0,3
Булавка	54,3	0,1	68,1	0,1	68,2	0,2	0,1	0,1
Крест	1069,3	2,8	1356,8	2,9	1166,8	2,6	-0,2	-0,3
Кольцо	13589,4	35,3	16283,4	34,2	14854,3	33,3	-2	-0,9
Подвеска	2854,9	7,4	3635,1	7,6	3228,2	7,2	-0,2	-0,4
Серьги	12087,8	31,4	17037,9	35,8	15449,2	34,6	3,2	-1,2
Цепь	6299,9	16,4	6449,5	13,6	6703,8	15	-1,4	1,4
Итого:	38484,7	100	47595,8	100	44666,2	100	X	X

Проанализировав структуру розничного товарооборота по группам товаров, можно сделать вывод, что наибольшую долю среди ассортиментных групп занимают товарные группы «Кольцо» и «Серьги». Доля колец в 2017 году составила 13589,4 тыс. р. или 35,3%, в 2018 году – 16283,4 тыс. р. или 34,2%, а в 2019 году – 14854,3 тыс. р. или 33,3%. Доля сережек составила в 2017 году 12087,8 тыс. р. или 31,4%, в 2018 году – 17037,9 тыс. р. или 35,8%, в 2019 году – 15449,2 тыс. р. или 34,6%. На рисунке 2 представлена доля товарных групп в структуре розничного товарооборота ООО «Александрит».

На рисунке 4 видно, что за исследуемый период наибольшее изменение структуры наблюдается у товарной группы «Серьги», она составила 3,2%. Наименьшее изменение наблюдается у товарной группы «Цепь», она составила -1,4%. Причиной этого могут быть высокие цены на данную товарную группу.



Рисунок 2 – Сравнительный анализ долей товарных групп в структуре товарооборота за 2019 год.

Далее проведем анализ равномерности и ритмичности розничного товарооборота. Под ритмичностью работы торговой организации понимают выполнение плана товарооборота по периодам (кварталам, месяцам, декадам). При ее оценке рассчитывается коэффициент равномерности, показывающий количественную однородность (равномерность) совокупных данных (таблица 5).

Таблица 5 – Расчет коэффициента равномерности выполнения плана товарооборота в ООО «Александрит» за 2019 г.

Квартал	2019 г., тыс. р.		Абсолютное отклонение плана, тыс. р. (+; -)	Выполнение плана, %
	План	Факт		
I	86856	95733	+8877	110,2
II	91706	106150	+14444	115,8
III	116447	115033	-1414	98,8
IV	112575	134018	+21443	119,1
Итого за период	407584	450934	+43350	110,6

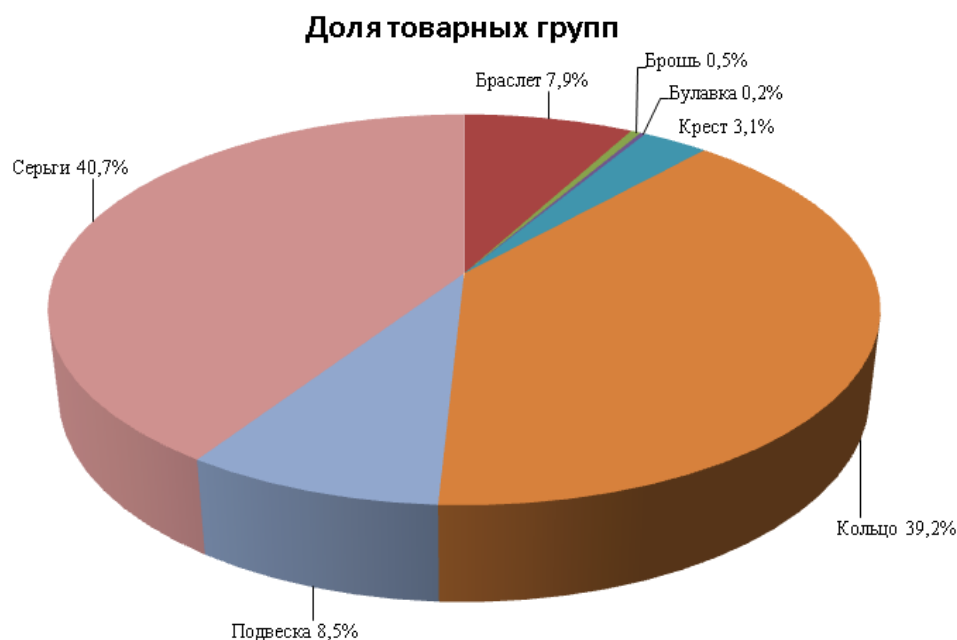
В таблице 6 проведем анализ равномерности выполнения плана розничного товарооборота ООО «Александрит» в разрезе кварталов отчетного года.

Таблица 6 – Анализ равномерности выполнения плана розничного товарооборота ООО «Александрит» за 2019 г.

Кварталы	Выполнение плана, %	$x_i - \bar{x}$	$(x_i - \bar{x})^2$	$\Sigma(x_i - \bar{x})^2 : n$	Коэффициент равномерности, %
I	110,2	-0,4	0,2	x	x
II	115,8	5,2	27	x	x
III	98,8	-11,8	139,2	x	x
IV	119,1	8,5	72,3	x	x
Итого за период	110,6	x	238,7	59,7	40,3

Коэффициент равномерности выполнения плана товарооборота в 2019 г. составил 40,3%.

Следующим этапом при изучении розничного товарооборота является анализ ритмичности розничного товарооборота.

В таблице 7 проведем анализ ритмичности розничного товарооборота в ООО «Александрит» по кварталам 2019 г.

Таблица 17 – Анализ ритмичности розничного товарооборота по кварталам 2019 г.

Квартал	Фактически за 2018 г., тыс. р.	2019 г., тыс. р.		Отклонение от плана, тыс. р.	Выполнение плана, %
		План	Факт		
I	74632	86856	95733	+8877	110,2
II	87690	91706	106150	+14444	115,8
III	99423	116447	115033	-1414	98,8
IV	103605	112575	134018	+21443	119,1
Итого за период	365350	407584	450934	+43350	110,6

Согласно таблице 17, объем фактического товарооборота превысил плановое значение 10,6%. План по розничному товарообороту ООО «Александрит» в 2019 г. был не выполнен только в третьем квартале. Во четвертом квартале наблюдается наибольшее выполнение плана, которое составило 119,1%.



Рисунок 3 – Равномерность выполнения плана розничного товарооборота по кварталам 2019 года ООО «Александрит»

Чтобы наиболее наглядно представить ритмичность розничного товарооборота, можно отобразить ее на графике или рисунке. Таким образом, оценка равномерности выполнения плана розничного товарооборота за 2018 год в графическом выражении по кварталам представлена на рисунке 3.

Из таблицы 7 и рисунка 3 видно, что ритмичность розничного товарооборота ООО «Александрит» составила 1,01, что свидетельствует о положительной ритмичности продаж в отчетном периоде.

Таким образом, из анализа розничного товарооборота ООО «Александрит» за 2017 – 2019 гг., можно сделать вывод, что с каждым годом наблюдается увеличение фактического розничного товарооборота, следовательно, наблюдается увеличение валового дохода предприятия.

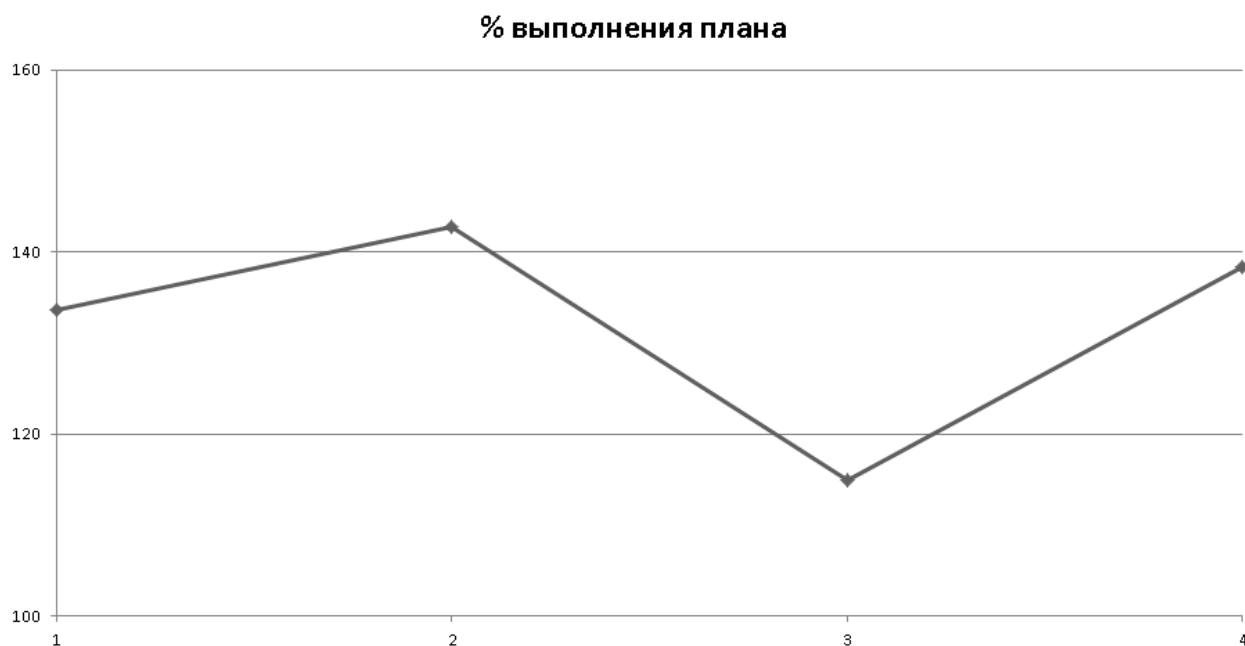
Использованные источники:

1. Брен, И. П. Анализ хозяйственной деятельности предприятий торговли и общественного питания: учеб. пособие / И. П. Брен, Г. В. Митрофанов. – Москва : Высш. шк., 2015. – 231 с.
2. Кравченко, Л. И. Анализ хозяйственной деятельности в торговле : учеб. пособие / Л. И. Кравченко. – Москва : Новое знание, 2016. – 544 с.
3. Нечитайло, А. И. Комплексный экономический анализ хозяйственной деятельности : учеб. пособие / А. И. Нечитайло, И. А. Нечитайло. – Ростов на Дону : Феникс, 2015. – 365 с.
4. Плыкина, Л. В. Экономический анализ предприятия : учеб. пособие / Л. В. Прыкина. – Москва : ЮНИТИ-ДАНА, 2015. – 407 с.

5. Савицкая, Г. В. Анализ хозяйственной деятельности предприятия : учеб. пособие / Г. В. Савицкая. – Москва : ИНФРА-М, 2015. – 400 с.
6. Чувикова, В. В. Бухгалтерский учет и анализ : учеб. пособие / В. В. Чувикова, Т. Б. Иззука. – Москва : Дашков и К, 2015. – 248 с.

*Ли Сашиа
студент*

*Московский финансово-промышленный университет «Синергия»
Россия, Москва*

СПОРТИВНЫЙ МАРКЕТИНГ В УСЛОВИЯХ ПАНДЕМИИ COVID-19

Аннотация. В статье рассматривается актуальная проблема, связанная с коронавирусной инфекцией, которая захватила мир. Говорится о ее влиянии на функционирование спортивных организаций в целом и на отдел маркетинга в частности. Приводятся принципы, которым должен следовать успешный маркетолог для решения задач в нынешнее непростое время.

Ключевые слова: Коронавирус, маркетинг, спорт, актуальность, контент, COVID-19, бизнес, влияние.

*Li Sasha
student*

*Moscow Financial and Industrial University «Synergy»
Russia, Moscow*

SPORTS MARKETING IN THE CONTEXT OF THE COVID-19 PANDEMIC

Annotation. The article deals with the actual problem related to the coronavirus infection that has taken over the world. It is said about its impact on the functioning of sports organizations in General, and on the marketing Department in particular. The principles which are given a successful marketer should follow to solve problems in these difficult times.

Key words: Coronavirus, marketing, sport, relevance, content, COVID-19, business, impact.

Эпидемия covid-19 ударила по всем сферам деятельности во всем мире.

Сильнейший удар получила спортивная сфера. Новые правила или запрет проведения спортивных мероприятий оказало очень сильное влияние на деятельность спортивных организаций. Оффлайн реклама полностью потеряла свою эффективность. В то же время, интернет реклама показывает себя очень результативно.

Эпидемия поставила вопрос не только экономики, но и человечества в целом. Спортивные организации всеми способами пытаются минимизировать убытки.

Спортивным маркетологам необходимо понять и изучить всю ситуацию и найти решение для эффективного продвижения спортивных продуктов и услуг в условиях эпидемии.

Для начала необходимо рассмотреть те изменения, что происходят сейчас в мире и обществе, и которые непосредственно влияют на решение поставленных вопросов: Во-первых, большинство людей перешли на удаленную работу, а значит больше времени проводят дома за компьютером и в сети интернет, и меньше за пределами своей квартиры. Во-вторых, как уже говорилось выше, безусловно больше всего страдают сфера оффлайн-бизнеса, т.е. продуктовые магазины, HoReCa, сфера развлечений, туризм, спорт и прочее.

Поскольку люди стараются быть на изоляции и осуществляют работу удаленно, то

набирает популярность сфера онлайн-развлечений из-за увеличившегося количества свободного времени. Необходимо отметить, что помимо всего прочего страдает спортивный ивент-маркетинг. Появляются новые тренды и течения, следуя которым можно достичь определенных успехов в своей деятельности.

Рассмотрим перечень необходимых действий для спортивных маркетологов, в условиях эпидемии и глобальных изменений в обществе:

1. Усиленный контроль бюджета.

Кризис создал нехватку средств для спортивных организаций. Необходимо грамотно провести анализ бюджетов и при необходимости их реструктурировать. Ошибкой будет уменьшение бюджета отделов маркетинга. Компании, которые во время пандемии грамотно направят бюджет в эффективную рекламу, имеют в перспективе шансы укрепить положение бренда на рынке и сохранить продажи.

Репутация стабильной спортивной организации в будущем принесет большие результаты. Это означает, что при падении потребительской способности населения важно ставить приоритетом маркетинговых компаний лояльных клиентов.

Нужно сказать, что бездумное увеличение бюджета рекламы также будет ошибкой. При любом бюджетном менеджменте важно сохранение рентабельности проекта

2. Своевременная адаптация под изменения рынка.

Кризисные условия и нестабильность потребительской способности требует моментального реагирования на изменения со стороны маркетологов. Также необходимо прогнозировать состояние спортивного рынка после окончания эпидемии чтобы подготовить маркетинговые компании к новым трудностям.

Анализ конкурентов и из маркетинговых решений также должна быть частью маркетинговой деятельности.

3. Постоянное функционирование SEO.

Эпидемия закончится рано или поздно. Сейчас подходящее время для анализа и создания новых путей развития для организации.

4. Анализ поисковых тенденций.

Необходимо быть в курсе того, что сейчас актуально для потребителей, и, отталкиваясь от этого, будет возможность создавать релевантный контент. Например, спортивные товары для самостоятельного занятия спортом имеют огромный спрос. Позитивный контент с участием известных спортсменов дают огромный обратный эффект.

5. Своевременность и актуальность контента.

В такие моменты все потребители нуждаются в позитивном контенте. Трансляция спортивных мероприятий через интернет платформу не только порадует фанатов спорта, но и привлечет новых любителей. Поэтому нужно пользоваться высокой загруженностью интернета и развернуть ситуацию с эпидемией в свою пользу спортивной организации.

6. Усиление цифрового контента.

Оффлайн маркетинг практически потерял свою эффективность в условиях карантина и изоляции. Интернет стал главным сектором рекламных компаний. Большинство спортивных мероприятий проходят без присутствия зрителей на месте проведения. Практически весь трафик посещения матчей и соревнований перешло в онлайн.

7. Работа над запланированными маркетинговыми проектами

До эпидемии у большинства спортивных организаций были свои планы продвижения. Однако, не стоит останавливаться и сбрасывать эти планы со счетов из-за эпидемии. Не смотря на то, что условия кардинально изменились, нужно адаптироваться под новые условия существования во время мировой эпидемии. Например, если компания планировала запуск нового спортивного продукта или услуги, стоит сделать это так, чтобы этот проект подошел под нынешнюю обстановку.

Делая вывод, стоит отметить, что все эти принципы, естественно, не являются исчерпывающими, однако они могут помочь спортивным организациям дальше функционировать, а сотрудники отдела маркетинга сделают всевозможное для достижения цели компании.

Использованные источники:

1. Буян Ю.Г. Маркетинг в спорте[Cyberleninka]// Журнал экономики и бизнеса.-2019.- №5-1(63) (дата публикации: 12.11.2019).- URL: <https://cyberleninka.ru/article/n/marketing-v-sporte/viewer> (дата обращения: 18.12.2020)
2. Степанова О.Н. Маркетинг в сфере физической культуры и спорта: Монография. – М.:Сов. спорт. 2010.

*Литвина С.О.
студент магистратуры департамента магистратуры
(бизнес-программ)
Тольяттинский государственный университет*

СОВЕРШЕНСТВОВАНИЕ МЕТОДИКИ ОПРЕДЕЛЕНИЯ СТАВКИ ДИСКОНТИРОВАНИЯ ДЛЯ ОЦЕНКИ СТОИМОСТИ ПРЕДПРИЯТИЙ ДОХОДНЫМ ПОДХОДОМ

Аннотация: В настоящей статье выделены внутренние факторы, оказывающие влияние на стоимость предприятия, в разрезе подходов к оценке стоимости. На основании этого предложена методика определения ставки дисконтирования для оценки стоимости предприятия, основанная на кумулятивном методе, в рамках которой дополнены факторы риска при определении премии за риск, среди которых ликвидность оцениваемого предприятия, вероятность банкротства предприятия, величина кредитного риска, система управления рисками.

Ключевые слова: Ставка дисконтирования, оценка бизнеса, доходный подход, метод дисконтирования денежных потоков, кумулятивный метод, риск.

*Litvina S.O.
master's student of the Department of Master's
(business programs)
Togliatti State University*

IMPROVEMENT OF THE METHODOLOGY OF DETERMINING THE DISCOUNTING RATE FOR ESTIMATING THE VALUE OF ENTERPRISES BY THE INCOME APPROACH

Annotation. This article highlights the internal factors affecting the value of the enterprise, in the context of approaches to cost estimation. Based on this, a method is proposed for determining the discount rate for assessing the value of an enterprise, based on the cumulative method, within which risk factors are added when determining the risk premium, including the liquidity of the assessed company, the likelihood of bankruptcy of the company, the amount of credit risk, and the risk management system.

Keywords. Discount rate, business valuation, income approach, method of discounting cash flows, cumulative method, risk.

В процессе своей деятельности многие хозяйствующие субъекты сталкиваются с необходимостью проведения оценки стоимости

предприятия, это могут быть как сами предприятия, так и сторонние лица. При этом результаты проведения оценки стоимости предприятия во многом зависят от различных факторов. В текущей практике оценочной деятельности применяется множество методов проведения оценки стоимости предприятия. Теоретико-методологические и практические аспекты проведения оценки стоимости предприятия рассматриваются в трудах таких исследователей, как А. Дамодаран [1], Н.Э. Барамия [2], В.В. Подгорный [3], Д.С. Харрисон [4], З. К. Мерсер [5] и другие. При этом в современной литературе отсутствует единая методика проведения оценки стоимости предприятий той или иной отрасли.

Одним из ключевых методов оценки стоимости предприятия выступает метод дисконтирования денежных потоков, на результаты оценки существенное влияние оказывает ставка дисконтирования, которая может определяться также различными методами.

В связи с чем целью настоящей статьи выступает разработка наиболее объективной методики определения ставки дисконтирования для оценки стоимости предприятия, основанная на кумулятивном методе, в рамках которой будут учитываться ключевые факторы, которые могут оказывать влияние на стоимость предприятия.

Анализ подходов и методов проведения оценки стоимости предприятия позволил выявить внутренние факторы, оказывающие влияние на стоимость предприятия, в разрезе оценки стоимости предприятия в соответствии с различными подходами [6], [7]. Факторы отражены в таблице 1

Таблица 1 - Внутренние факторы, оказывающие влияние на стоимость предприятия, в разрезе подходов к оценке стоимости

Подход	Внутренние факторы
Затратный подход	Величина и динамика активов предприятия
	Ликвидность активов предприятия
	Износ внеоборотных активов
	Качество дебиторской задолженности
	Величина и динамика обязательств
	Затраты на ликвидацию предприятия
Доходный подход	Финансовые результаты за предыдущий период
	Темп прироста выручки, чистой прибыли
	Инвестиционная активность предприятия
	Прогнозный денежный поток от операционной деятельности
	Длительность прогнозного периода
	Величина ставки дисконтирования, методика расчёта величины ставки дисконтирования
	Риски деятельности предприятия
Сравнительный подход	Положение предприятия в отрасли
	Наличие компаний-аналогов
	Финансовое состояние предприятий-аналогов
	Финансовые результаты предприятия аналога
	Прогнозируемая чистая прибыль предприятия

Доходный подход выступает наиболее объективным и распространённым, так как он опирается на прогнозирование будущих доходов и прибылей предприятия, а также позволяет учесть факторы риска при определении ставки дисконтирования для проведения оценки и стоимость денег во времени [8].

Практика проведения оценки стоимости предприятий показывает, что наиболее применяемой и объективной моделью расчёта ставки дисконтирования выступает кумулятивная модель. Суть кумулятивной модели состоит в том, что к величине безрисковой ставки последовательно прибавляются премии за различные виды рисков. То есть факторы риска, которые учитываются в данной модели, могут быть различны [9].

Наиболее распространённой кумулятивной моделью при оценке стоимости предприятий выступает модель, предложенная З. Кристофером Мерсером. Так, З. Кристофер Мерсер предлагает добавлять к безрисковой ставке факторы, представленные на рисунке 1.



Рисунок 1 – Расчёт ставки дисконтирования кумулятивным методом (методика З. Кристофера Мерсера) [5]

С одной стороны, использование доходного подхода позволяет учесть будущие денежные потоки, с другой стороны – факторы риска. И именно выбранная ставка дисконтирования позволяет в значительной степени сделать оценку предприятия наиболее объективной. Для этого, на наш взгляд, в качестве факторов риска в ставку дисконтирования необходимо заложить факторы, которые также лежат за основу в затратном и сравнительном подходах.

Следует отметить, что используемые в методике З. Кристофера Мерсера факторы риска недостаточно полно отражают все внутренние и

внешние факторы, которые могут оказывать влияние на стоимость предприятия. То есть рассмотренная методика недостаточно полно и точно отражает факторы риска.

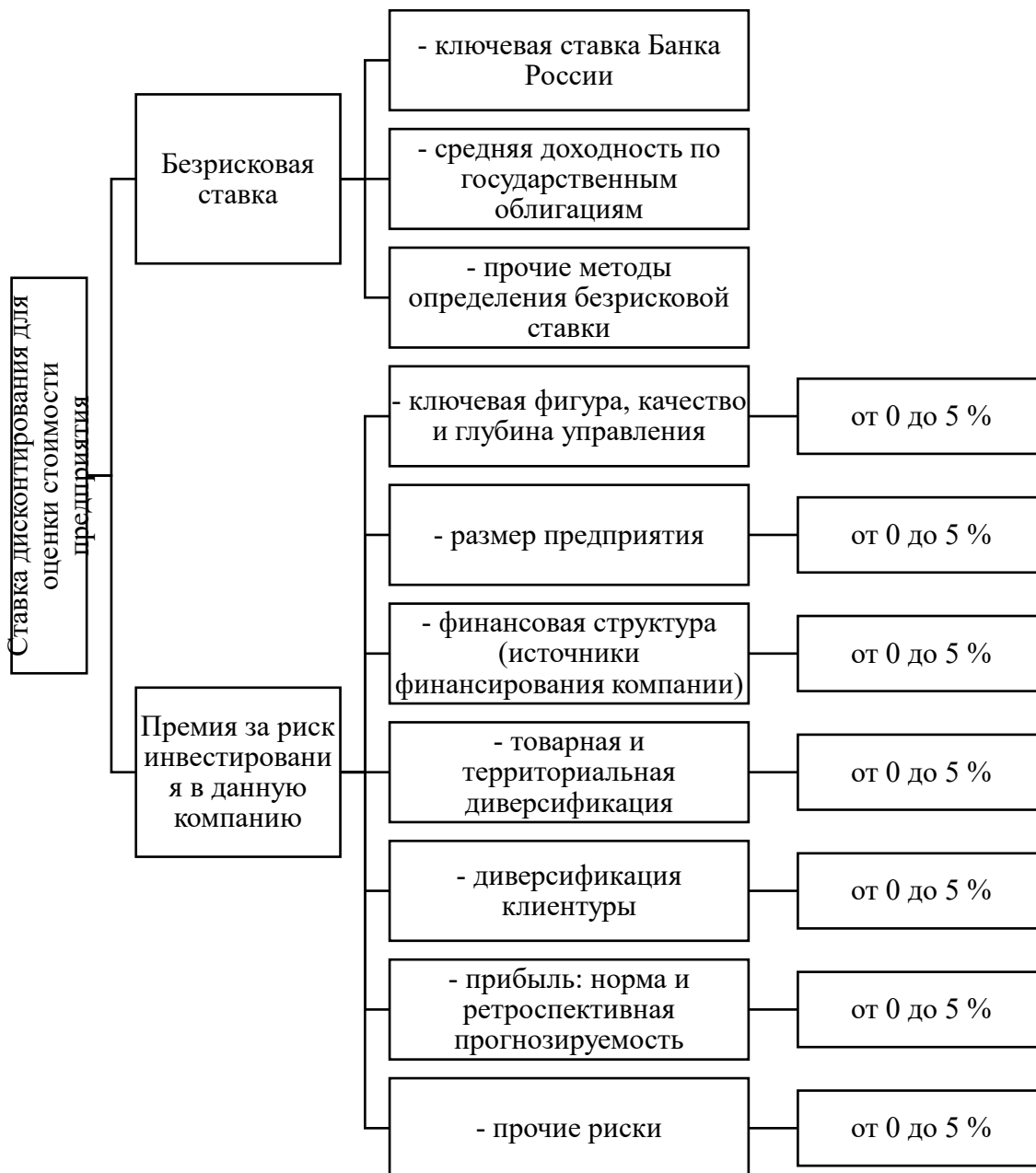
Так, такие факторы, как качество управления, размер предприятия, товарная и территориальная диверсификация, диверсификация клиентуры – это факторы, связанные с маркетинговой составляющей. Данные факторы больше отражает по своей специфике сравнительный подход.

Такие факторы, как финансовая структура (источники финансирования компании), прибыль: норма и ретроспективная прогнозируемость – это финансовые факторы, отражённые в ставке дисконтирования, которые дополняют прогнозируемые денежные потоки доходного подхода.

Факторы, отражающие особенности затратного подхода, в данной методике не учтены.

Таким образом, следует отметить, что данные факторы не позволяют в полной мере учесть все финансовые риски, связанные с деятельностью компании.

В связи с чем предлагается дополнить данные факторы такими факторами, как:

- ликвидность предприятия,
- вероятность банкротства предприятия,
- величина кредитного риска.

Более того, фактор «прочие риски» предлагается заменить на фактор «система управления рисками».

Ввиду того, что за каждый фактор риска диапазон премии составлял от 0% до 5 % и факторов было семь, суммарная величина премии за риск составляла 35 %.

В предлагаемой методике факторов – десять, в связи с чем предлагается за каждый фактор установить премию за риск от 0 до 3,5 %.

Таким образом, ключевыми факторами риска с предлагаемой методике будут выступать следующие:

- ключевая фигура, качество и глубина управления,
- размер предприятия,
- финансовая структура (источники финансирования компании),
- товарная и территориальная диверсификация,
- диверсификация клиентуры,
- прибыль: норма и ретроспективная прогнозируемость,
- ликвидность предприятия,
- вероятность банкротства предприятия,
- величина кредитного риска,
- система управления рисками.

Предлагаемая методика определения ставки дисконтирования в рамках кумулятивного метода представлена на рисунке 2.



Рисунок 2 – Предлагаемая методика определения ставки дисконтирования в рамках кумулятивного метода

Предлагаемая методика определения ставки дисконтирования позволит в большей степени учесть все факторы риска в деятельности предприятия, что повысит объективность проводимой оценки, так как будет учитывать большее количество факторов, оказывающих влияние на стоимость предприятия.

Использованные источники:

1. Асват Дамодаран. Инвестиционная оценка [Электронный ресурс]: инструменты и методы оценки любых активов/ Асват Дамодаран— Электрон. текстовые данные.— М.: Альпина Паблишер, 2017.— 1339 с.
2. Барамия Н.Э. Основные методы определения ставки дисконтирования при оценке стоимости бизнеса / Н.Э. Барамия // Молодой ученый. 2017. № 21 (155). С. 192-195.
3. Подгорный В.В. Оценка стоимости бизнеса [Электронный ресурс]: учебное пособие/ Подгорный В.В.— Электрон. текстовые данные.— Донецк: Донецкий государственный университет управления, 2016.— 233 с.— Режим доступа: <http://www.iprbookshop.ru/62363.html>.— ЭБС «IPRbooks». (дата обращения 15.03.2020).
4. Harrison D. S. Business valuation made simple: It's all about cash // Strategic Finance. – 2016 – Vol 2. – P. 44-48.
5. Christopher Mercer Z. The Adjusted Capital Asset Pricing Model for Developing Capitalization Rates: An Extension of Previous 'Build-Up' Methodologies Based Upon the Capital Asset Pricing Model // Business Valuation Review. 1989. № 4. P. 147-156
6. Битюцких В. Т. Формула стоимости. Оценка стоимости компаний: учебник / В. Т. Битюцких. – М.: Олимп-Бизнес, 2015. – 216 с.
7. Дадьян Д.В. Оценка стоимости бизнеса. / Д.В. Дадьян // Форум молодых ученых. - 2019. - № 3 (31). - С. 297-300.
8. Хасиев А.А. Практика применения доходного подхода к оценке бизнеса: достоинства и недостатки / А.А. Хасиев // Наука в современном мире: приоритеты развития. 2017. № 1 (3). С. 176-179.
9. Алхасова Р.М. Оценка степени риска и расчёт ставки дисконтирования в оценке бизнеса / Р.М. Алхасова // В сборнике: ЭКОНОМИЧЕСКАЯ НАУКА В 21 ВЕКЕ: ВОПРОСЫ ТЕОРИИ И ПРАКТИКИ сборник материалов X международной научно-практической конференции. НИЦ «Апробация». 2016. С. 10-14.

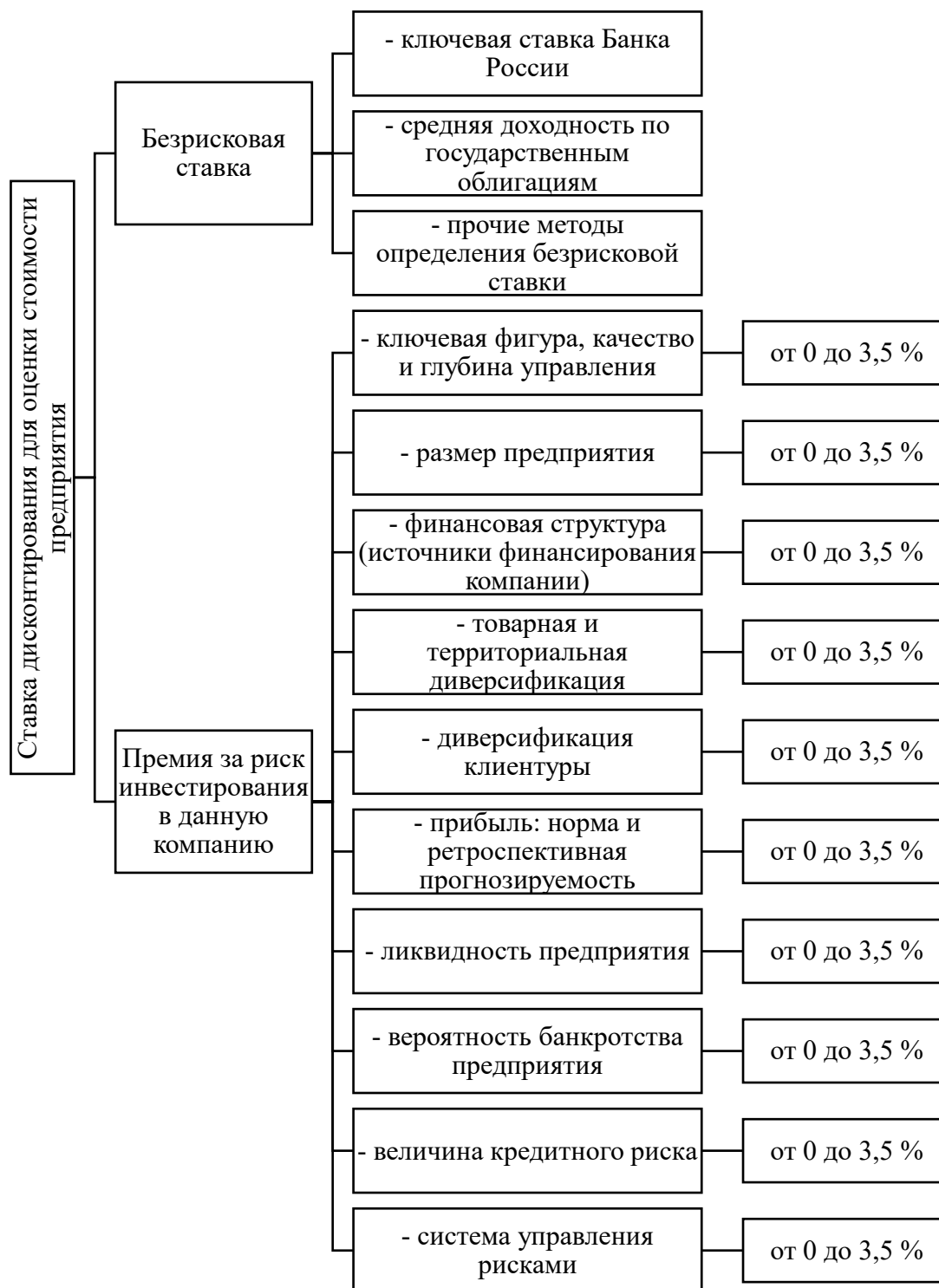
*Лихолетова Н.В., кандидат экономических наук
доцент кафедры экономики, философии и социальных дисциплин
ФГБОУ ВО Донской государственной аграрной университет
Россия, п. Персиановский*

СОВЕРШЕНСТВОВАНИЕ СОСТАВЛЕНИЯ ОТЧЕТА ДВИЖЕНИЯ ДЕНЕЖНЫХ СРЕДСТВ В СЕЛЬСКОХОЗЯЙСТВЕННОМ ПРЕДПРИЯТИИ

Аннотация: Актуальность статьи заключается в том, что анализ движения денежных потоков имеет важное значение для правильной организации денежного обращения, расчетов и кредитования, поддержание сбалансированности между высоким уровнем рентабельности работы организации и достаточной ее платежеспособностью. Успешное решение возникающих в сельскохозяйственных организациях финансовых проблем во многом зависит именно от совершенствования составления отчета о движении денежных средств

Ключевые слова: денежные средства, сельскохозяйственное предприятие, международные стандарты финансовой отчетности, отчет о движении денежных средств, прибыль

*Likholetova N. V., PhD in economics
associate Professor of Economics, philosophy and social Sciences
Don state agrarian University
Russia, p. Persianovsky*

IMPROVING THE PREPARATION OF A CASH FLOW REPORT IN AN AGRICULTURAL ENTERPRISE

Abstract: The relevance of the article lies in the fact that the analysis of cash flows is important for the correct organization of monetary circulation, settlements and lending, maintaining a balance between a high level of profitability of the organization and its sufficient solvency. The successful solution of financial problems that arise in agricultural organizations largely depends on improving the preparation of the cash flow report

Keywords: cash, agricultural enterprise, international financial reporting standards, cash flow statement, profit

На современном этапе развития аналитическая информация как один из инструментов производственно-финансового механизма аграрной бизнес-среды становится все более важной и актуальной при разработке

нового метода финансового анализа, адекватного условиям глобализации и интеграции. В первую очередь это связано с тем, что Россия вступила во Всемирную торговую организацию и, согласно действующим соглашениям, обязана вести учет и анализ с использованием методологии международных стандартов финансовой отчетности (МСФО). Внедрение МСФО на сельскохозяйственных предприятиях является важным шагом для создания благоприятного инвестиционного климата и, как следствие, экономического роста.

Международные стандарты финансовой отчетности содержат положения о движении денежных средств. Важным источником анализа для управления денежными потоками является отчет о движении денежных средств.

Подготовка отчета о движении денежных средств регулируется международным стандартом финансовой отчетности (IAS) 7 «Отчет о движении денежных средств». Целью настоящего стандарта является требование предоставления информации об исторических изменениях денежных средств и их эквивалентов в форме отчета о движении денежных средств, в котором классифицируются денежные потоки от текущей, инвестиционной и финансовой деятельности за отчетный период.

Отчет о движении денежных средств должен содержать информацию о движении денежных средств за отчетный период с разбивкой на потоки от текущей, инвестиционной или финансовой деятельности.

В таблице 1 рассмотрены требования к составлению отчёта о движении денежных средств.

Согласно МСФО (IAS) 7 отчет о движении денежных средств может быть составлен прямым или косвенным методом.

Таблица 1 – Требования к составлению отчета о движении денежных средств

Требования российского законодательства до принятия ПБУ 23/2011	Требования МСФО 7
Не учитываются поступления и выбытие денежных эквивалентов	Инвестиция, чтобы квалифицироваться в качестве эквивалента денежных средств, должна быть легко обратимой в определенную сумму денежных средств и подвергаться незначительному риску изменения стоимости (п. п. 7 и 15 МСФО 7)
Банковские овердрафты учитываются при составлении отчета о движении денежных средств	При составлении отчета о движении денежных средств в соответствии с МСФО 7 банковские овердрафты могут включаться в состав денежных эквивалентов, если они возмещаются по требованию и имеют отрицательное сальдо с противоположным знаком (п. 8 МСФО 7)
Не допускается зачет между статьями отчета о движении денежных средств	Организации могут свернуто отражать поступления и выбытия денежных средств (нетто-оценка) (п. 22 МСФО 7)
Дивиденды, выплаченные акционерам, отражаются в составе платежей по текущей деятельности	Выплаченные дивиденды могут классифицироваться как финансовые потоки денежных средств, так как они являются затратами на привлечение финансовых ресурсов (п. 34 МСФО 7)
Платежи по налогам и сборам отражаются в составе платежей по текущей деятельности	Денежные потоки, возникающие в связи с налогом на прибыль, должны раскрываться отдельно и классифицироваться как денежные потоки от операционной (текущей) деятельности, если только они не могут быть конкретно увязаны с финансовой или инвестиционной деятельностью (п. п. 35, 36 МСФО 7)
Обязанность раскрывать не доступные для использования остатки денежных средств и эквивалентов денежных средств не предусмотрена	Организация должна раскрывать в пояснениях сумму значительных остатков денежных средств и эквивалентов денежных средств, имеющих у нее, но не доступных для использования (п. 48 МСФО 7)
Обязанность раскрывать дополнительную информацию о денежных потоках по географическим сегментам не установлена	В отчете о движении денежных средств поощряется раскрытие дополнительной информации о сумме денежных потоков, возникающих от операционной, инвестиционной и финансовой деятельности, отраженной в отчетах отрасли или географического сегмента (пп. п. 50, п. 62 МСФО 14)

<p>Денежные средства в иностранной валюте пересчитываются в рубли по курсу Банка России на дату составления бухгалтерской отчетности (п. 16 Указаний о порядке составления и представления бухгалтерско отчетности, утвержденных Приказом Минфина России от 22 июля 2003 г. N 67н)</p>	<p>Денежные средства в иностранной валюте пересчитываются в рубли по курсу Банка России на дату совершения операции (п. 25 МСФО 7)</p>
--	--

Для сельскохозяйственного предприятия необходимо использовать расчетный метод с использованием прямого и косвенного метода. При использовании прямого метода расчета чистый приток (отток) денежных средств от операционной деятельности рассчитывается как разница между доходами, полученными от фактических денежных потоков, и расходами, связанными с фактическими платежами. Начальным показателем является выручка от продаж.

В соответствии с требованиями МСФО применительно к российской практике косвенный метод направлен на получение данных, характеризующих чистый денежный поток организации в отчетном периоде. Источником информации для составления отчетов о движении денежных средств организации с использованием данного метода являются: бухгалтерский баланс и отчет о финансовых результатах.

Чистый денежный поток организации рассчитывается косвенно по видам деятельности и организации в целом (табл.2).

Таблица 2 – Расчет денежного потока прямым и косвенным методом по российским стандартам

Прямой метод	Косвенный метод
<p>Денежный поток равен поступление денежных средств, формирующих доход (например, продажа за наличные, доходы в виде полученных процентов) минус расходы, связанные с выплатами денежных средств (например, оплата материала, выплата заработной платы)</p>	<p>Денежный поток равен годовая прибыль (годовой убыток) плюс расходы, не связанные с выплатами денежных средств (например, амортизационные отчисления, создание резервов) минус доходы, не связанные с поступлением денежных средств (например, повышение балансовой стоимости основных средств, доходы от расформирования ненужных более резервов)</p>

Прямой метод позволяет, в отличие от косвенного метода, получить представление о структуре текущих денежных поступлений (оборотов) и фактических платежей организации. Это показывает фактические источники и направления использования средств в ходе основной

хозяйственной деятельности. Поэтому прямой метод следует рассматривать как более информативный [1].

В отличие от прямого метода, косвенный метод рассчитывает чистый приток (отток) денежных средств от текущей деятельности на основе годовой прибыли (убытка), скорректированной на все без исключения расходы и доходы, не связанные с реальными денежными потоками, в первую очередь амортизационные отчисления и такие, например, доходы, как дебиторская задолженность.

Слабая сторона косвенного метода заключается в том, что денежный поток в виде выручки от продаж и текущих расходов, связанных с денежными платежами (которые обычно являются наиболее важным денежным оттоком), таким образом, упускается из виду. Таким образом, важная цель отчета о движении денежных средств – получение информации о том, как генерируются средства, – не выполняется. Эта ограниченная информативность сопоставима с расчетом прибылей и убытков, который ориентирован не на отдельные статьи расходов и доходов, а на годовую прибыль (убыток) [2].

Можно сделать вывод, что для улучшения подготовки отчета о движении денежных средств сельскохозяйственному предприятию необходимо перейти на отчетность в соответствии с требованиями МСФО, что приблизит отчетность предприятия к международным стандартам. Таким образом, инвестор может получить дополнительную информацию из отчета о движении денежных средств в соответствии с требованиями МСФО и выявить причины изменения сумм денежных средств и их эквивалентов.

Использованные источники:

1. Лихолетова, Н.В. Интерпретация результатов анализа финансового состояния сельскохозяйственных организаций // Передовые технологии в науке и образовании: сборник материалов Международной научно-практической конференции (15 июля 2020 г.), – Кемерово: ЗапСибНЦ, 2020. С.54-58
2. Шестопад, Е. Отчёт о движении денежных средств // Российский бухгалтер. – 2013. – №8. С.22-26.

*Лукьяненко П.А.
студент магистратуры
Российская академия народного хозяйства и государственной службы
при Президенте РФ Брянский филиал
Россия, Брянск*

**ПРАВОВОЕ РЕГУЛИРОВАНИЕ ВЗАИМОДЕЙСТВИЯ ОРГАНОВ
ВЛАСТИ СУБЪЕКТА РОССИЙСКОЙ ФЕДЕРАЦИИ И ОРГАНОВ
МЕСТНОГО САМОУПРАВЛЕНИЯ**

Аннотация: Рассматриваются основные формы взаимодействия органов государственной власти субъектов Российской Федерации и местного самоуправления, содержание их и система.

Ключевые слова: органы государственной власти, местное самоуправление.

*Lukyanenko P.A.
master's student
Russian Presidential Academy of National Economy and Public
Administration Bryansk Branch
Russia, Bryansk*

**LEGAL REGULATION OF INTERACTION BETWEEN THE
AUTHORITIES OF THE SUBJECT OF THE RUSSIAN FEDERATION
AND LOCAL SELF-GOVERNMENT BODIES**

Annotation: The main forms of interaction between state authorities of the subjects of the Russian Federation and local self-government, their content and system are considered.

Keywords: state authorities, local self-government.

Проблема взаимодействия органов государственной власти и органов местного самоуправления на протяжении многих лет обсуждается правоведами, т. к. залогом устойчивого функционирования и развития любого государства является эффективная работа, правильное определение принципов и форм взаимодействия органов государственной власти и органов местного самоуправления.

Для обеспечения согласованности государственных (региональных) и местных интересов, построения эффективной системы государственного и муниципального управления работает механизм сотрудничества и разграничения полномочий между органами государственной власти и органами местного самоуправления.

Под органом местного самоуправления понимается такой орган муниципального образования, который формируется на основании непосредственного волеизъявления населения или представительным органом муниципального образования и наделяется своими собственными полномочиями для решения определенных задач местного значения¹³⁴.

Исходя из положений ст. 12 Конституции Российской Федерации, органы местного самоуправления не входят в систему государственных органов власти.

Деятельность органа местного самоуправления, не являющегося органом государственной власти, носит тем не менее властный характер, поскольку является формой реализации своей власти народом. Следовательно, решения, которые принимает орган местного самоуправления, будут являться обязательными в пределах муниципального образования для всех участников правоотношений.

Орган государственной власти представляет собой часть государственного механизма, имеющего свои определенные полномочия по контролю разных областей общественных отношений в силу нормативно-правовых актов.

Разноплановость задач и проблем, решаемых государством, вызывает необходимость формирования специального аппарата управления и отдельных структур государственных органов, наделенных рядом полномочий, компетенцией и функциональной обособленностью.

Их совокупностью и взаимодействием обеспечивается целостность государства и выражение интересов народа, являющегося, исходя из положений ст. 3 Конституции Российской Федерации, источником власти. Улучшение качества жизни населения в пределах муниципального образования является и единой целью совместной деятельности органов местного самоуправления и органов государственной власти.

Указанная совместная деятельность обладает определенными отличительными признаками:

- присутствие в правоотношении двух и более субъектов;
- активная и результативная деятельность обоих субъектов правоотношения, выражающаяся в том, что действия и решения первого субъекта влияют на второго субъекта;
- согласованность в действиях обоих субъектов;
- наличие единой задачи, на решение которой и направлена совместная работа субъектов.

Рассмотрим на примере исполнения административного законодательства субъекта и деятельности административных комиссий при соответствующем органе местного самоуправления Краснодарского края проблемные вопросы взаимодействия органов местного

¹³⁴ Безруков А.В. Государственная власть и местное самоуправление: проблемы соотношения и взаимодействия// Конституционное и муниципальное право. - 2019. - № 6.С.11.

самоуправления с органами государственной власти.

Конкретные локальные особенности каждого субъекта Российской Федерации, специфика социально-экономических факторов и явлений общественной жизни населения конкретного региона с учетом географического положения, социокультурных, национальных обычаев и традиций, местной бытовой специфики, особенностей природных ресурсов, рациональности их использования и экологических факторов безопасности населения, которые в недостаточной мере урегулированы Кодексом Российской Федерации об административных правонарушениях, требуют издания соответствующего закона, удовлетворяющего потребности населения субъекта. Закон по осуществлению правового регулирования общественных отношений субъекта Российской Федерации не должен вступать в противоречие с федеральным законодательством и исключать случаи нарушения прав и законных интересов физических и юридических лиц при его применении.

При этом региональный законодатель устанавливает административную ответственность исключительно за нарушение своего же законодательства и законодательства органов местного самоуправления, определяя полномочия должностных лиц по составлению административных протоколов и подведомственность рассмотрения дел об административных правонарушениях.

В каждом субъекте Российской Федерации существуют и исполняются законы об административных правонарушениях, которые удовлетворяют общественную потребность нормативного регулирования в сфере упорядочения общественных отношений и управления и основываются на специфике конкретного региона.

Анализ законов субъектов Российской Федерации об административных правонарушениях показал, что регулируемые сферы общественных отношений в них выступают: права и законные интересы граждан, связанные со здоровьем и санитарно-эпидемиологическим благополучием, окружающей природной средой, землепользованием и природопользованием, жилищно-коммунальной сферой, благоустройством и санитарными нормами, сельским хозяйством и содержанием животных, сферой транспорта и строительства, предпринимательской деятельностью, институтами государственной власти субъектов Российской Федерации и местным самоуправлением¹³⁵.

Так, например, курортные регионы Кубани требуют урегулирования вопросов установления административной ответственности за нарушение запретов на пляжах и в других местах массового отдыха на водных объектах, а также за приставание к гражданам с целью гадания и попрошайничества.

¹³⁵ Карташов В. Г. Взаимодействие органов государственной власти субъекта Российской Федерации и органов местного самоуправления // Конституционное и муниципальное право. 2019. № 19.С.11.

Однако у должностных лиц муниципальных образований, уполномоченных составлять протоколы об административных правонарушениях, возникает проблема реализации своих полномочий без помощи сотрудника полиции или иных представителей власти.

Данные проблемы связаны с установлением личности правонарушителя, пресечением его агрессивного поведения и оскорбления должностных лиц; необладанием правом задержания правонарушителя и применения к нему физической силы, специальных средств и иных мер принуждения.

Кроме того, нет возможности осуществлять полномочия в ночное время суток, проблемно взыскать административный штраф, т. е. исполнить законное наказание.

В данной ситуации очевидна необходимость оказания содействия в привлечении виновных к ответственности сотрудниками полиции (должностными лицами органов власти, относящихся к так называемым федеральным министерствам и ведомствам), у которых при возбуждении дел об административных правонарушениях по закону субъекта, в свою очередь, возникает ряд проблемных вопросов.

Конституционным Судом Российской Федерации 2 июля 2018 г. вынесено Постановление № 27-П, разъясняющее разграничение полномочий и порядок взаимодействия сотрудников полиции, являющихся представителями государственного органа, с муниципальными служащими по содействию в процессуальном реагировании на административные правонарушения и привлечению к ответственности нарушителей по законам субъекта.

В полномочия полицейских Кубани, согласно Соглашению между МВД Российской Федерации и администрацией Краснодарского края, передано составление протоколов об административных правонарушениях, связанных с нарушением требований к выгулу собак, приставанием к гражданам с целью гадания и попрошайничества, а также совершением действий, нарушающих тишину и покой граждан, и направление на рассмотрение соответствующих материалов в адрес уполномоченных органов исполнительной власти.

Коллегиальным органом муниципального образования является административная комиссия, образование и организация деятельности которой на Кубани урегулированы Законом Краснодарского края от 14 декабря 2006 г. № 1144-КЗ. Административные комиссии рассматривают дела об административных правонарушениях, совершенных на территории муниципального образования, ответственность за которые предусмотрена региональным законом¹³⁶.

¹³⁶ Кудинов В. В. К вопросу о формах взаимодействия органов государственной власти и органов местного самоуправления по защите Государственной границы Российской Федерации // Государственная власть и местное самоуправление. 2019. № 8.С.18.

Работа административной комиссии попадает под перечисленные выше признаки взаимодействия органов местного самоуправления с органами государственной власти: присутствуют два субъекта правоотношения; оба субъекта действуют активно (сотрудник полиции составляет протокол об административном правонарушении, по которому принимает решение административная комиссия); присутствует согласованная совместная деятельность органа местного самоуправления и органа государственной власти (предупреждение, пресечение и профилактика совершения административных правонарушений); есть единая цель, на выполнение которой и направлено взаимодействие (уменьшение количества административных правонарушений среди населения муниципального образования).

Взаимодействие сотрудников полиции, являющихся представителями органа государственной власти, пресекающих противоправную деятельность гражданина, совершившего административное правонарушение, осуществляется с органом местного самоуправления, в данном случае - с административной комиссией, принимающей решение по делу об административном правонарушении.

Помимо принятия решений о привлечении лиц к ответственности путем рассмотрения административной комиссией дел об административных правонарушениях, исходя из положений ст. 14 Закона Краснодарского края № 1144-КЗ, административные комиссии координируют свою деятельность с правоохранительными органами в целях предупреждения и профилактики правонарушений. Примером этого служат организация и проведение совместных патрулирований, рейдовых мероприятий, участие в профилактических операциях, организация сходов и собраний граждан, проведение координационных совещаний.

Исходя из предназначения полиции защищать жизнь, здоровье, права и свободы граждан, противодействовать преступности, охранять общественный порядок, собственность и обеспечивать общественную безопасность на всей территории Российской Федерации, определенного в ст. 1 Федерального закона «О полиции» от 7 февраля 2011 г. № 3-ФЗ, а также обязанности оказывать содействие региональным властям, органам местного самоуправления и иным муниципальным органам, следует, соответственно, и реализация ими всего комплекса мер реагирования на любые административные правонарушения (в т. ч. ответственность за которые установлена региональным законом).

Сотрудники полиции могут осуществлять административное задержание лиц, проводить личный досмотр, изъятие вещей и документов, а также досмотр транспортных средств в соответствии с полномочиями, предусмотренными федеральным законодательством при оказании содействия и самостоятельном составлении административных протоколов по закону субъекта федерации.

Также стоит отметить, что в распоряжении субъектов Российской Федерации имеются достаточные правовые средства, позволяющие взять на себя отдельные полномочия государственных органов и самостоятельно осуществлять производство по делам об административных правонарушениях, предусмотренных законом субъекта.

Так, например, вполне успешно реализуется выявление административных правонарушений и их документирование должностными лицами органов муниципального образования в сфере защиты прав потребителей, организации транспортного обслуживания населения, охраны окружающей среды и природопользования.

Нельзя также не отметить наличие полномочий возбуждать дела о любых административных правонарушениях, независимо от уровня нормативного правового акта, прокурору при осуществлении надзора за соблюдением действующего законодательства, что является дополнительной гарантией соблюдения регионального законодательства.

Проблемам охраны общественного порядка на территории муниципалитета неоднократно уделялось внимание со стороны исследователей-правоведов, обосновывающих востребованность создания муниципальной милиции как части муниципальной структуры, перенимающей определенные полномочия МВД, основные функции которой будут сосредоточены на решении местных задач, исполнении административного законодательства субъекта федерации и потребностей общества в охране общественного порядка. Несмотря на имеющийся исторический опыт создания и успешного функционирования подобной структуры в государстве, перспективны создания муниципальной милиции подвергаются критике и являются дискуссионными.

Однако, возвращаясь к вопросу потребностей региона, в частности конкретного муниципалитета, считаем необходимым привести пример формирования специальных подразделений туристической полиции в муниципальных образованиях, нуждающихся в дополнительных силах для обеспечения безопасности гостей и иностранных туристов¹³⁷.

Завершая исследование проблемы взаимодействия органов государственной власти и органов местного самоуправления при реализации административного законодательства субъекта федерации, считаем целесообразным сделать вывод, что вопросы привлечения виновных лиц за нарушения, предусмотренные региональным законодательством, имеют должную эффективность лишь в случаях наличия не только закона о подобающем поведении граждан муниципального образования, но и санкций за нарушение предписаний закона. Так, на территории Кубани, как и в других регионах России, долгое время существует так называемый детский закон, не допускающий

¹³⁷ Безруков А.В. Роль законодательной власти в системе разделения властей и механизме обеспечения правопорядка в России // Современное право. 2015.- № 6. - С. 25.

нахождение несовершеннолетних в общественных местах без сопровождения законных представителей в ночное время. Необходимость и целесообразность указанного закона обусловлена прежде всего предупреждением вреда здоровью детей и профилактикой совершения в их отношении преступлений. Кроме того, статистические данные подтверждают эффективность его реализации в профилактике безнадзорности, снижении подростковой преступности и правонарушений несовершеннолетних, детского травматизма.

Однако обеспечение соблюдения данного ограничения является предписывающим, поскольку санкции за его нарушение в случаях выявления нахождения несовершеннолетнего в ночное время в общественном месте в настоящее время Законом Краснодарского края № 608-КЗ от 23 июля 2003 г. не предусмотрены (т. к. ст. 2.9 указанного закона утратила силу). При выявлении несовершеннолетнего привлечь к ответственности законного представителя по статье 5.35 Кодекса об административных правонарушениях за неисполнение обязанностей по содержанию и воспитанию несовершеннолетнего не представляется возможным.

Полагаем, что санкции, утратившие силу, обеспечивали более серьезное отношение к требованиям регионального закона под угрозой привлечения к административной ответственности (наказанию) муниципальным образованием решением комиссии по делам несовершеннолетних и защите их прав.

Данный пример еще раз убедительно подтверждает необходимость существования регионального закона об административных правонарушениях, имеющего в своем составе санкции за допущенные нарушения.

В данной связи считаем целесообразным проанализировать состояние подростковой преступности и преступлений, совершенных в отношении несовершеннолетних, и в случае их роста вернуть силу ст. 2.9 Закона Краснодарского края № 608-КЗ.

Использованные источники:

Правовые акты

1. Конституция Российской Федерации: Принята всенародным голосованием 12 декабря 1993 года // Собрание законодательства Российской Федерации, 04.08.2014, № 31. Ст. 4398.
2. Европейская хартия местного самоуправления (совершено в Страсбурге 15.10.1985) // Собрание законодательства Российской Федерации, 07.09.1998, № 36. Ст. 4466.
3. Конвенция Совета Европы об уголовной ответственности за коррупцию (Страсбург, 27 января 1999 года) // Собрание законодательства Российской Федерации, 18.05.2009, № 20. Ст. 2394.

4. Федеральный конституционный закон от 26.02.1997 № 1-ФКЗ «Об Уполномоченном по правам человека в Российской Федерации» // Собрание законодательства Российской Федерации, 03.03.1997, № 9. Ст. 1011.
5. Кодекс Российской Федерации об административных правонарушениях от 30.12.2001 № 195-ФЗ // Собрание законодательства Российской Федерации, 07.01.2002, № 1 (ч. 1). Ст. 1.
6. Федеральный закон от 06.10. 2003 № 131-ФЗ «Об общих принципах организации местного самоуправления в Российской Федерации» // Собрание законодательства Российской Федерации, 06.10.2003, № 40. Ст. 3822.

Специальная литература

7. Баглай М.В. Конституционное право Российской Федерации: Учебник. - 13-е изд., изм. и доп. - М.: Инфра-М, 2018. 789с.
8. Бондарь Н. С. Гражданин и публичная власть: конституционное обеспечение прав и свобод в местном самоуправлении : учеб. пособие / Н. С. Бондарь. М.: Городец, 2018. -856с.
9. Жеребцов А. Н., Павлов Н. В. Административная правоприменительная практика: теоретический и практический аспекты: монография. М.: Юстицинформ, 2018. 168 с.
10. Кутафин О. Е. Муниципальное право Российской Федерации / О. Е. Кутафин, В. И. Фадеев. 3-е изд., перераб. и доп. - М.: Проспект, 2019. -856с.

Публикации периодической печати

11. Безруков А.В. Роль законодательной власти в системе разделения властей и механизме обеспечения правопорядка в России // Современное право. 2015.- № 6. - С. 25 - 29.
12. Безруков А. В. Государственная власть и местное самоуправление: проблемы соотношения и взаимодействия// Конституционное и муниципальное право. - 2019. - № 6.С.11-19.
13. Карташов В. Г. Взаимодействие органов государственной власти субъекта Российской Федерации и органов местного самоуправления // Конституционное и муниципальное право. 2019. № 19.С.11-19.
14. Кравец И.А. Парламентаризм и бикамерализм в теории и российской истории //Конституционное и муниципальное право. 2018. № 4. С. 42 - 46.
15. Кудинов В. В. К вопросу о формах взаимодействия органов государственной власти и органов местного самоуправления по защите Государственной границы Российской Федерации // Государственная власть и местное самоуправление. 2019. № 8.С.18-25.
16. Павлов Н. В., Мирозян А. А. Ответственность органов местного самоуправления перед населением // Молодой ученый. 2019. № 49 (287). С. 381-383.

СВЯЗИ С ОБЩЕСТВЕННОСТЬЮ В ГОСУДАРСТВЕННОМ УПРАВЛЕНИИ

Аннотация: Статья посвящена значимости связей с общественностью в деятельности органов государственной власти. В силу процесса формирования новых общественных связей в стране и ростом потребностей в деятельности служб по связям с общественностью.

Ключевые слова: государственная служба, государственное управление, общественность, государственная власть, общество, связи с общественностью, PR-служба, государственное управление, государственный PR.

*Lusakueno J.K.
Ural Institute of Management - branch of RANEPА*

PUBLIC RELATIONS IN GOVERNMENT

The article is devoted to the importance of public relations in the activities of public authorities. Due to the process of the formation of new public relations in the country and the growing demand for the activities of public relations services.

Key words: public service, public administration, public, public authority, society, public relations, PR-service, public administration, public PR.

Глобальный характер приобретает проблема отношений общества и власти. Это происходит в условиях повсеместной информатизации и коммуникативной открытости. Перед органами государственной власти возникают проблемы в виде непривлекательного имиджа, апатии и недоверия граждан. Поэтому положительный имидж является чрезвычайно важным для государственных структур.

Под государственным управлением мы понимаем сферы взаимопроникновения и взаимосвязи политики и управления в процессе реализации управленческих решений, направленных на решение общественно значимых проблем во всех сферах жизни социума [2].

Если общество имеет адекватную реакцию на прямые регуляторные воздействия власти и умеет приспособиться к правилам и условиям развития, которое определяет воздействие власти, развитие государства и общества будет развиваться без социальных потрясений.

Органам государственной власти необходимо постоянно осуществлять дополнительное информационное взаимодействие с гражданами, публично разъяснять свои действия и решения. Отдельные граждане, институциональные структуры и общество в целом должны иметь возможность открыто выражать личное и коллективное отношение к действиям власти. Это поможет сформировать соответствующее психологическое, эмоциональное и моральное состояние общества.

Особой функцией руководства, способствующей установлению и поддержания связи, сотрудничества и взаимопонимания между организацией и общественностью является связь с общественностью. Связи с общественностью помогают руководству организации быть информированным об общественном мнении, а также своевременно реагировать на него. Главная задача связи с общественностью – служить интересам общественности.

Можно сказать, что связи с общественностью – это наука и искусство анализа тенденций развития общественных отношений.

Определим ряд специфических черт связей с общественностью в деятельности государственной власти:

- у органов государственной власти существует необходимый набор средств для организации успешной PR-деятельности.

- связи с общественностью имеют важное значение для органов государственной власти, потому что качественно разрабатываемая индивидуальная, высоко-профессиональная программа отразится на создании благоприятного имиджа власти [**Ошибка! Источник ссылки не найден.**].

Структуры связей с общественностью помогают создать условия (как внешние, так и внутренние), при которых организация могла бы развиваться наиболее гармонично, определяя при этом гармонию общества в целом. Роль этих структур особенно важна в период кризиса, когда речь идет просто о незамедлительном реагировании и быстром и четком общении с общественностью. При возникновении социальных проблем государство в целях реагирования создает новые министерства и ведомства в правительстве, которые отвечают за их решения [1].

Изучение опыта органов государственной власти в области связей с общественностью показывает, что повышение эффективности деятельности тесно связано с необходимостью использования всех видов коммуникаций, имеющих в комплексе. Перед отделами по связям с общественностью в современной России стоит целый ряд задач, требующих от них многопланового выбора средств их решения, видов стратегических сценариев и тактик, способствующих формированию позитивного имиджа государственной службы.

Функциональные характеристики деятельности государственной службы в системе государственной службы определяют их организационную структуру.

Как показывает практика, в большинстве случаев структуры, занимающиеся связями с общественностью на государственной службе, могут состоять из четырех подразделений:

- Информационно-аналитический отдел.
- Отдел по информационным коммуникациям.
- Отдел по работе с политическими партиями и общественными организациями.
- Организационно-правовой отдел.

Существуют технологии для связей с общественностью, начиная от общения с небольшим кругом людей и заканчивая средствами массовой информации с неограниченной аудиторией. В случае государственных структур объектом воздействия общественных отношений является налогоплательщик, гражданин, который хочет иметь право знать о действиях государственных органов разных уровней. Президент, правительство, губернатор, мэр - все они с некоторой регулярностью используют различные каналы связи (пресса, радио, телевидение, Интернет), чтобы попытаться раскрыть все аспекты своей работы.

Таким образом, оптимизация общественных отношений в системе государственной службы является одним из существенных условий формирования гражданского общества, взаимодействующего с верховенством права и саморегулированием государственного аппарата при осуществлении государственного управления [3].

В связи с этим органы власти на различном уровне (федеральном, региональном, местном) должны осуществлять свою деятельность в режиме открытости и прозрачности. Все это получает отражение в Конституции Российской Федерации и ряде Федеральных законов [4].

Таким образом, органы власти должны выстраивать коммуникационные связи и выявлять общественное мнение прежде, чем принимать решения, которые повлияют на характер принимаемых решений. Успеха можно достичь только в том случае, когда обе стороны взаимно соглашаются друг с другом. Данную взаимосвязь отмечают отечественные авторы, которые подчеркивают, что многодисциплинарная практика в области связей с общественностью подчеркивает важность взаимоотношений между органами власти и общественностью. По их мнению, выбор и конструкция применяемых в данном направлении PR технологий, элементы будущего имиджа должны опираться на общественное мнение. Именно его соответствие ожиданиям людей является первоначальным залогом успеха [6].

Связи с общественностью играют очень важную роль в правительстве. Они способствуют реализации государственной политики, создают

положительный имидж государственных структур, помогают средствам массовой информации освещать деятельность правительства, с их помощью граждане информируются о деятельности органов власти, способствуют внутренней сплоченности органов государственной власти, повышают чувствительность и внимание органов власти к нуждам и желаниям общества.

Таким образом, оптимизация связей с общественностью в системе государственной службы является одним из существенных условий формирования гражданского общества, взаимодействующего с верховенством права и саморегулированием государственного аппарата при осуществлении публичного администрирования.

Главная задача связей с общественностью – создание имиджа компетентного и эффективного руководства, обладающего сильной властью и способного решать стоящие перед ним проблемы, не ущемляя при этом конституционных прав граждан на получение полной и достоверной информации. К сожалению, сейчас кажется, что власти даже не в состоянии отреагировать в нужное время. Но это также открывает большие возможности для связей с общественностью в области государственного управления.

Использованные источники:

1. Государственное управление: основы теории и организации / Под ред. В.А. Козбаненко. – М.: Статус, 2011. – 379 с.
2. Комаровский, В.С. Связи с общественностью в политике и государственном управлении / В.С. Комаровский. – М.: РАГС, 2010. – 341 с.
3. Кондратьев, Э.В. Связи с общественностью: учебное пособие для высшей школы / Э.В. Кондратьев. – М.: Академический Проект, 2012. – 352 с.
4. Шейнов, В.П. Пиар «белый» и «черный»: Технология скрытого управления людьми / В.П. Шейнов. - М.: АСТ; МН.: Харвест, 2011. – 384 с.

УДК 78.07

Ляшенко В.В.
доцент кафедры инструментовки и чтения партитур
Военный университет
Москва
Кавторев В.В.
преподаватель кафедры инструментовки и чтения партитур
Военный университет
Москва

К ВОПРОСУ О РЕФОРМЕ РУССКОЙ ВОЕННОЙ МУЗЫКИ ВО ВТОРОЙ ПОЛОВИНЕ 19 ВЕКА

Аннотация: В статье рассматриваются некоторые аспекты реформирования отечественной военной музыки во второй половине 19 века, связанные с усовершенствованием оркестровых составов, упразднением многостройности духовых инструментов, введением новых форм обучения военных музыкантов и капельмейстеров.

Ключевые слова: Военная музыка, капельмейстер, инспектор музыкантских хоров Морского ведомства.

Lyashenko V.V.
associate professor of the Department of Instrumentation and reading of
scores Military university
Moscow
Kavtrev V.V.
lecturer at the Department of Instrumentation and reading scores
Military University
Moscow

RUSSIAN MILITARY MUSIC OF THE SECOND HALF OF THE 19TH CENTURY

Annotation: The reform of the military band in the second half of the 19th century had important consequences for the development of naval and army bands. The improvement of the orchestral composition, the abolition of a lot of harmony of wind instruments, the training of military bandmasters and other significant transformations in the military orchestral business of those years are considered in this article.

Keywords: Military music, conductor, inspector of music choirs of the Naval Department.

Вторая половина 19 века – время реформ и модернизации русской армии и флота. Вместо рекрутского набора в 1874 году вводится всеобщая воинская повинность. Большие изменения происходят в перевооружении. На смену кремневым ружьям и гладкоствольным пушкам приходят нарезная артиллерия и многозарядная винтовка. Парусный флот уступает место паровому, оснащеному сложными механизмами.¹³⁸ Перемены произошли и в сфере военной музыки.

Существенной особенностью военно-оркестрового дела в первой половине 19 века было отсутствие централизованного руководства военными оркестрами, что приводило к неорганизованности комплектования военных оркестров, несогласованности их инструментальных составов. Для решения этих задач в 1856 году принимается новое «Положение о музыкальных хорах», в котором утверждается определенный состав военного оркестра – медный хор с валторнами.

Проведению реформ и усилению интереса к военной музыке в определенной степени способствовало проведение европейского конкурса военных оркестров на Парижской выставке в 1867 году, в котором приняли участие и русские коллективы.

В реформе военной музыки активно участвовали профессиональные музыканты. Так, профессор Петербургской консерватории В. Вурм, составил сборник русских полковых встречных маршей, написал «Школу для корнета, трубы и сигнального рожка». Его сочинения не утратили своего значения до настоящего времени.

Помимо штатных военных оркестров в полках и на кораблях по инициативе группы офицеров формируются и внештатные коллективы. Создается общество любителей духовой музыки, систематически устраиваются концерты. В полках и батальонах организуются многочисленные певческие хоры, исполняющие строевые, лирические и шуточные солдатские песни.

В 1873 году утверждается должность инспектора музыкантских хоров морского ведомства. На эту должность назначается морской офицер, композитор Н.А. Римский-Корсаков.¹³⁹ За время службы им была осуществлена реорганизация штатных составов военных оркестров морского ведомства. Инструментальный состав оркестров приводится к трем, наиболее удобным строям духовых инструментов – В, Еs и F.

Для подготовки музыкантов военных оркестров по инициативе Н.А. Римского-Корсакова создается музыкальная школа Балтийского флота. Лучшие выпускники, закончившие школу с отличием, продолжали обучение в стенах Петербургской консерватории и рекомендовались к назначению на должности капельмейстеров.

¹³⁸ В. Матвеев Русский военный оркестр. М., 1965, с. 45

¹³⁹ Н.А. Римский – Корсаков Летопись моей музыкальной жизни /С.-Петербург 1909,с.119

Показателем успешной работы Римского-Корсакова явились ежегодные концерты сводных военных оркестров, что способствовало росту их профессионального и исполнительского мастерства. Военные оркестры с успехом участвовали в международных творческих состязаниях, проводившихся в Париже и Брюсселе. В репертуаре оркестров были такие произведения как «Камаринская» и увертюра к опере «Руслан и Людмила» М. Глинки, «Венгерская рапсодия № 2» Ф. Листа, музыка из балета Ж. Массне «Король Лагорский».

Таким образом, можно сделать вывод о подъеме уровня отечественной военной музыки в этот период. Это было обусловлено проведением ряда реформ, в результате которых были оптимизированы составы и строи инструментов военных оркестров, сформированы специализированные учебные заведения для подготовки военно-музыкальных кадров, расширен репертуар военных оркестров.

Использованные источники:

1. Матвеев В. Русский военный оркестр. М. 1965.
2. Римский-Корсаков Н.А. Летопись моей музыкальной жизни. СПб, 1909.

*Мадиханова Б.М.
преподаватель кафедры узбекского языка,
педагогике и физической культуры
факультет защиты растений и агрохимии
Андижанский институт сельского хозяйства и агрохимии
Узбекистан, г. Андижан*

ТЕОРЕТИЧЕСКИЙ АСПЕКТ ТЕХНОЛОГИЙ ОБУЧЕНИЯ РУССКОМУ ЯЗЫКУ КАК ВТОРОМУ

Аннотация: Актуальность и открытость проблемы эффективного обучения русскому языку определили ее актуальность, а значит, и выбор темы для данной курсовой работы.

Также определена цель работы: выделить наиболее рациональные методы обучения русскому языку, которые можно использовать в учебном процессе. Предметом данной статьи является процесс обучения и учащиеся, являющиеся его участниками.

Ключевые слова: учебный процесс, студенты, образование, обучение, методы, технологии, принципы, общение.

*Madikhanova B.M.
assistant of the department of Uzbek language, pedagogy and
physical culture
Andijan Institute of Agriculture and Agro technology
Uzbekistan, Andijan*

THEORETICAL ASPECT OF TECHNOLOGIES OF TEACHING A RUSSIAN LANGUAGE AS A SECOND

Abstract: The relevance and openness of the problem of effective teaching Russian languages determined its relevance, and therefore, the choice of topic for this course work. The purpose of the work is also determined: to highlight the most rational methods of teaching a Russian language that can be used in the educational process. The subject of this article is the learning process and the students who are the subjects of this learning process.

Key words: educational process, students, education, teaching, methods, technologies, principles, communication.

Принципы обучения понимаются как исходные утверждения, которые определяют цели, содержание, методы и организацию обучения и проявляются во взаимосвязи и взаимообусловленности. В нашем случае принципы используются для определения стратегии и тактики обучения

английскому языку на всех этапах практически в каждой точке учебного процесса.

Поскольку результатом обучения студентов иностранному языку является формирование у них навыков использования языка как средства общения, ведущим принципом является принцип коммуникативной направленности [2;116].

Его основная функция - создание всех условий общения: мотивов, целей и проблем общения. Коммуникативная направленность определяет выбор и организацию языкового материала, его ситуативную обусловленность, коммуникативную ценность как речи, так и учебных упражнений, коммуникативную постановку учебных задач, организацию и структуру урока. Этот принцип предполагает создание условий для разговорной и интеллектуальной деятельности студентов в каждый момент обучения.

Исходя из вышесказанного, педагог должен соблюдать правила:

1) Принцип коммуникативной направленности:

- ✓ Подбор ситуаций.
- ✓ Повторяемость и новизна.
- ✓ Участие всех в половом акте.
- ✓ Благоприятные условия для полового акта.
- ✓ Коммуникативность задач.

Поскольку у школьников еще незначительный опыт коллективного общения и их учат не только общаться на английском, но и вообще общаться, учитель должен оказывать поддержку в реализации учениками моделей общения на родном языке, реализуя коммуникативную функцию той или иной языковой единицы. Реализация этого принципа осуществляется через систему познавательных задач, решая которые дети «открывают» законы родного языка.

На основе этого осознания происходит знакомство детей с формой и функциями соответствующих единиц английского языка.

Исходя из этого, можно наметить некоторые правила - соблюдение которых позволяет реализовать этот принцип в учебно-воспитательном процессе.

2) Принцип поддержки на родном языке:

- ✓ Отображение общности русского и английского языков.
- ✓ Формирование общих образовательных навыков.
- ✓ Использование сходства и различий в сценарии.
- ✓ Использование сходства и различий в произношении.
- ✓ Использование переноски и недопущение вмешательства в обучение лексике и грамматике.

Установлено, что для каждого вида речевой деятельности «набор» действий и даже лексико-грамматическое оформление. Это позволило

сформулировать методический принцип дифференцированного подхода в обучении иностранному языку.

При этом дифференциация проводится как бы на разных уровнях обобщения - в обучении проводится четкая дифференциация:

- ✓ Устная и письменная речь;
- ✓ Говорить и слушать;
- ✓ Чтение вслух и чтение молча;
- ✓ Написание и орфография.

В обучении русскому языку реализуется процесс интеграции, он показывает, прежде всего, что усвоение различных аспектов языка, его фонетики, грамматики, лексики происходит не отдельно, как отдельные дискретные компоненты языка, а также интегрируется. Студенты усваивают и усваивают их при проведении речевых действий, реализация которых может потребовать употребления слова, словоформ, словосочетания, сверхфразового единства и, наконец, текста, вызванного ситуациями общения.

Учитывая данный конкретный принцип обучения русскому языку, можно сформулировать правила, их соблюдение поможет учителю реализовать этот принцип.

3) Принцип дифференциации и интеграции:

- ✓ Учет специфики каждого вида речевой деятельности.
- ✓ Использование речи учителя и звукозаписи для прослушивания.
- ✓ Обучение монологической речи, исходя из особенностей каждой формы.
- ✓ Обучение чтению вслух и молча с учетом особенностей каждой формы.
- ✓ Освоение языковых аспектов в речевых единицах.
- ✓ При обучении письму используйте полу текстовый шрифт.

В основе преподавания любого предмета в образовании, в том числе русского, лежат общие дидактические принципы. Такими принципами являются: научность, доступность, презентабельность в обучении, индивидуальный подход в условиях коллективной работы и другие.

Частные и общие дидактические принципы выражают типичное, главное, существенное, что должно характеризовать обучение русскому языку и, прежде всего, на начальном этапе, когда этим предметом закладываются основы усвоения. Понимание действия принципов обучения и непосредственное использование правил позволит учителю эффективно проводить обучение [3; 24].

Обучение - это активный процесс, который осуществляется путем вовлечения учеников в различные виды деятельности, что делает их активными участниками получения образования. В этом двустороннем процессе можно выделить основные функции, выполняемые каждой своей частью. Педагог выполняет организационные, обучающие и

контролирующие функции. В функции студента входит ознакомление с учебным материалом, обучение, необходимое для формирования языковых навыков и разговорных навыков, и применение исследуемого языка при решении коммуникативных задач [1; 36].

Благодаря тренировке память ученика обогащается новыми языковыми единицами и развивается автоматизм в их использовании. При применении новой лексики наиболее четко проявляется организующая функция учителя. Он должен создать благоприятные условия, доброжелательную атмосферу для нормального протекания речевого акта. Он должен создать такие условия, в которых каждый студент хотел бы участвовать в работе группы и понимать текст, который они прочитали или слушали, и не боялись ошибиться. При применении новой лексики контролируется формулировка речевых навыков, устанавливается, каким образом обучающийся может использовать каждое из них в практических целях.

Рассмотренные методы отражают сущность педагогического процесса, в котором учитель взаимодействует с другими. Эти методы используются в обучении иностранному языку при учебном процессе, раскрытии специфики учебного предмета и направлены на достижение практических, учебных и развивающих целей.

Использованные источники:

1. Усмонов Н. Лингводидактический потенциал мультипликационных фильмов в обучении русскому языку как иностранному языку. Международный научный журнал. Вопросы науки и образования. № 11 (95) -с.: 2020.
2. Тиллабоева Ф.А. Подходы и принципы обучения русского языка. Международный научный журнал. Экономика и общество. № 6 (73) -с .: 2020.
3. С.Жаббарова «Значение образования и воспитания в истории Средней Азии» Международный научно-практический журнал «Современные исследования» Выпуск № 5(9), Самара, 2018.

*Майструк В.А.
студент магистратуры
СЗИУ РАНХиГС при президенте РФ
РФ, Санкт-Петербург
Дудин Н.В.
студент магистратуры
СЗИУ РАНХиГС при президенте РФ
РФ, г. Санкт-Петербург*

МОДЕРНИЗАЦИЯ ТЕХНОЛОГИЧЕСКИХ РЕЖИМОВ НЕФТЕГАЗОВОГО КОМПЛЕКСА ЗАПАДНОЙ СИБИРИ

Аннотация: В статье рассматриваются перспективы и особенности модернизации технологических режимов нефтегазового комплекса Западной Сибири. Отдельное внимание уделено технологиям повышения эффективности объемов извлечения углеводородов из глубинных скважин. Также рассмотрены инновационные разработки в области увеличения глубины переработки нефти. Особый акцент сделан на необходимости проведения оценки экономической и технологической эффективности внедряемых мероприятий.

Ключевые слова: нефть, газ, добыча, скважина, технологии, Сибирь.

*Maystruk V.A.
magister student
North-West Institute of Management of the Russian Academy
of national economy under the President
of the Russian Federation Russia
Russia, St.Petersburg
Dudin N.V.
magister student
North-West Institute of Management of the Russian Academy
of national economy under the President
of the Russian Federation Russia
Russia, St.Petersburg*

MODERNIZATION OF TECHNOLOGICAL MODELS OF THE OIL AND GAS COMPLEX OF WESTERN SIBERIA

The article discusses the prospects and features of the modernization of technological modes of the oil and gas complex of Western Siberia. Special attention is paid to technologies for increasing the efficiency of hydrocarbon extraction volumes from deep wells. Also considered are innovative developments in the field

of increasing the depth of oil refining. Special emphasis is placed on the need to assess the economic and technological efficiency of the measures being implemented.

Key words: oil, gas, production, well, technologies, Siberia.

Западно-Сибирский нефтегазовый комплекс является одним из крупнейших в мире и самый большой в Российской Федерации регион по добыче нефти и газа. Данные обстоятельства обуславливают тот факт, что Западно-Сибирский нефтегазовый комплекс является на протяжении практически полувека главной сырьевой базой энергетики, нефтеперерабатывающей и нефтехимической промышленности России и важнейшим поставщиком продукции для экспорта (нефть и газ) в страны Западной Европы (см. табл. 1).

Таблица 1 Суммарные запасы нефти и газа на территории России, % [1]

Регион	Сумма углеводородов	Нефть	Газ		Конденсат
			Свободный	Растворенный	
Суша	73,9	87,6	67,9	84,3	77,6
Россия, всего	100	100	100	100	100
Шельф	26,2	12,5	33,4	15,9	21,8
Западная Сибирь	44,7	54,7	42,1	53,8	42,0
Европейская часть России	12,3	19,8	6,5	18,2	16,9
Дальний Восток	4,2	2,8	3,9	3,4	4,6
Восточная Сибирь	12,6	10,2	14,1	8,7	14,7
Доля Сибири и Дальнего Востока (с учетом шельфа), %	88,1	79,4	92,2	80,9	82,6

Реализация нефти и газа, добываемого на Западной Сибири составляет доминирующий источник формирования бюджета Российской Федерации и формирует ключевые валютные поступления в страну.

Крупнейшие российские вертикально-интегрированные нефтегазовые компании, работающие на Западной Сибири в 2014-2019 гг., заметно нарастили экспорт нефти за счет оптимизации объемов переработки: «Роснефть», «Лукойл», «Газпромнефть» поставили на экспорт 195 млн. т. (75% всего экспорта) (см. рис. 1).



Рис. 1 Экспорт нефти крупнейшими компаниями Западной Сибири (млн. т.) [2]

В тоже время, несмотря на все достижения и позитивные моменты необходимо отметить, что в последние годы издержки нефтегазовых компаний растут быстрее рентабельности, капитальные затраты увеличиваются в среднем на 20% в год. Старые месторождения, которые эксплуатируются еще со времен СССР в значительной степени выработаны и обводнены, что предполагает необходимость открытия новых скважин и соответственно существенных инвестиций в их разработку. На рис. 2 представлены актуальные и прогнозные значения капиталовложений в нефтедобычу.

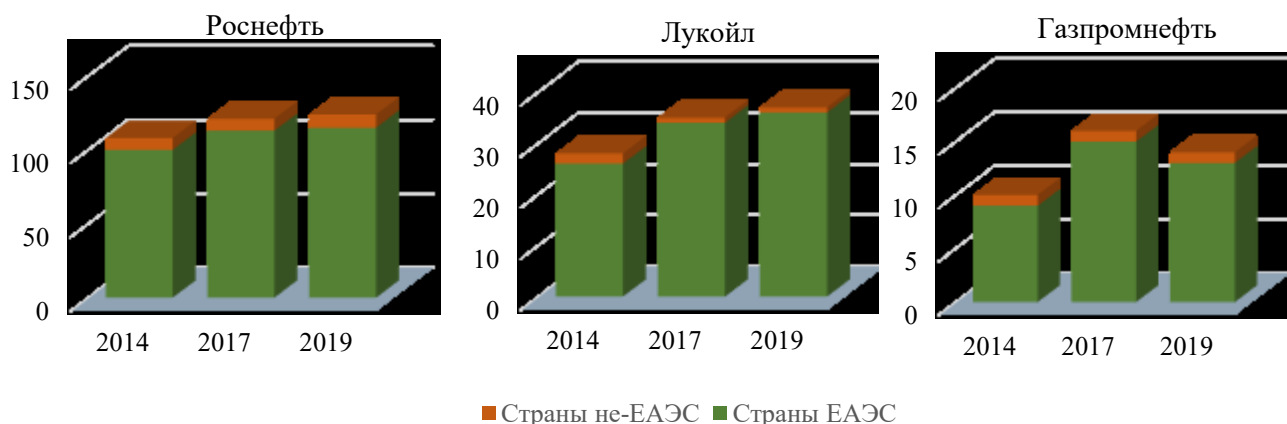

Рис. 2 Капиталовложения в нефтедобычу, млрд. руб. [3]

Указанные обстоятельства в свою очередь обостряют проблему модернизации и внедрения инноваций в технологические режимы работы добывающих компаний. В результате особую актуальность на сегодняшний день приобретают вопросы построения целостной системы обеспечения опережающего инновационного развития и технологического оснащения нефтегазового комплекса Западной Сибири.

Мировой опыт убеждает в необходимости разработки эффективного организационно-экономического механизма, который способствовал бы инновационной политике в нефтедобывающем и нефтеперерабатывающем комплексе. Путем внедрения инновационных технологий, современных технологических процессов возможно увеличить глубину переработки нефти

отечественных заводов и улучшить качество получаемых нефтепродуктов.

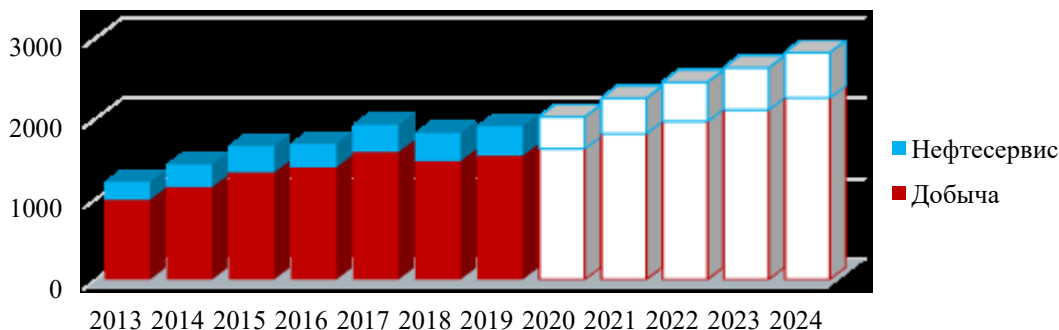
Таким образом, актуальность темы данной статьи не вызывает сомнений, а приведенные факты подтверждают ее научно-практическую значимость.

Проблемам развития топливно-энергетического комплекса России и его секторов сегодня уделяется большое внимание со стороны отечественных ученых-исследователей, таких как: Брехунцов А.М., Нестеров И.И., Нечипорук Л.А., Тимурзиев А.И., Карлусов В.В., Ярков Д.А. и др.

Основные тенденции развития нефтегазового комплекса Западной Сибири в контексте современных экономических процессов детально анализируются в работах Филимоновой И.В., Эдера Л.В., Немова В.Ю., Проворной И.В., Казаненкова В.А., Олейника Е.В., Оксенойда Е.Е. и др.

Обзору и изучению технологических достижений, перспективных инновационных решений для нефтегазовой отрасли посвящены труды известных западных исследователей: Ribeiro, Cássio G., Boul, Peter J., Emma Chiavaro, Junchen, Li; Xiucheng, Dong; Höök, Mikael; Jian, Gao; Shiqun, Li.

С проблемой повышения объемов нефтеизвлечения из пластов, совершенствованием процессов нефтепереработки, технико-технологической модернизацией геологоразведочных работ уже несколько десятилетий сталкиваются нефтяные компании во всех регионах мира. Однако разные периоды разработки месторождений характеризуются различными подходами к решению задач оптимизации и представлениями об целесообразности и сфере применения методов, а также конкретных технологий повышения эффективности работы нефтегазовых комплексов.

Принимая во внимание вышеизложенное, цель статьи заключается в изучении на основе передового международного опыта особенностей и перспектив модернизации технологических режимов нефтегазового комплекса Западной Сибири.

Итак, представляется, что главная задача модернизации технологических режимов нефтегазового комплекса Западной Сибири заключается в использовании передовых технологий по интенсификации нефтегазодобычи и повышению объемов извлечения углеводородов из глубоких скважин; развитию системы глубокой переработки нефти; внедрении в производство структурных геолого-геофизических моделей; расширении удельного веса поставок как внутренним, так и международным потребителем продукции, которая имеет высокую добавленную стоимость; разработке глобальной системы нефтегазообеспечения, которая будет контролироваться правительством России и бизнесом; создании диверсифицированной коммерчески и технологически эффективной системы экспортных поставок.

Очевидно, что в рамках одной статьи рассмотреть все направления не представляется возможным, поэтому остановимся более детально на первых двух.

В мировой практике для добычи полезных углеводородов из высоких глубин используется два подхода к модернизации нефтяных скважин с целью улучшения нефтедобычи: *Enhanced Oil Recovery (EOR)* и *Improved Oil Recovery (IOR)*. Первый подход включает в себя методы, которые основаны на применении вытеснительных агентов, отличающихся от воды (газовые, тепловые, микробиологические и химические методы); второй подход базируется на технологиях воздействия на скважину и прочих методах, которые приводят к интенсификации добычи нефти и косвенно к росту нефтеизвлечения.

Методы повышения нефтеизвлечения (методы первой группы) представляют собой комплекс принципиальных технологических решений, направленных на улучшение выработки запасов нефти по сравнению с традиционным методом заводнения. Особенностью этих методов является необходимость проведения крупных научно-исследовательских работ в каждом конкретном случае, а также их высокая стоимость, повышенный технологический и экономический риск [4].

Ко второй группе, включающей гидродинамические методы роста нефтеизвлечения из пластов, входят способы и технологии, которые успешно апробированы современной наукой и практикой, и предполагают использование типовых задач и решений на основе разработанных программно-имитационных моделей.

Так, данные с месторождения Alpine (США) свидетельствуют о том, за счет использования гидродинамических методов в 2019 г. средняя эффективность добычи нефти возросла более чем вдвое. Именно поэтому нефтегазодобывающие компании, работающие на этом месторождении, начиная с 2019 года увеличили объемы внедрения высокоэффективных методов воздействия на пласт.

На рис. 3 представлена эффективность методов повышения нефтеизвлечения на примере ConocoPhillips, которая ведет добычу на месторождении Alpine.



Рис. 3 Эффективность методов повышения нефтеизвлечения, используемых ConocoPhillips на месторождении Alpine (тыс. т.) [5]

Как свидетельствует рис. 3 наиболее эффективными из методов повышения нефтеизвлечения в 2018-2019 гг. были: срезка боковых стволов (4,89-5,29 тыс. т), бурение горизонтальных скважин (4,32-7,84 тыс. т.), ГРП (3,05 тыс. т).

Особое значение в комплексе технологий, которые позволят повысить эффективность нефтегазового комплекса Западной Сибири в контексте роста нефтеотдачи, по мнению автора, имеют потоко-регулирующие технологии, которые реализуются путем проведения обработок нагнетательных скважин различными химическими композициями. На сегодня день в результате внедрения потоко-регулирующих технологий в мире ежегодно добывается около 15-20 млн. тонн нефти [6].

В России данные технологии также постепенно находят свое применение и в таблице 2 представлены среднестатистические показатели, отражающие результаты их использования на некоторых нефтяных месторождениях.

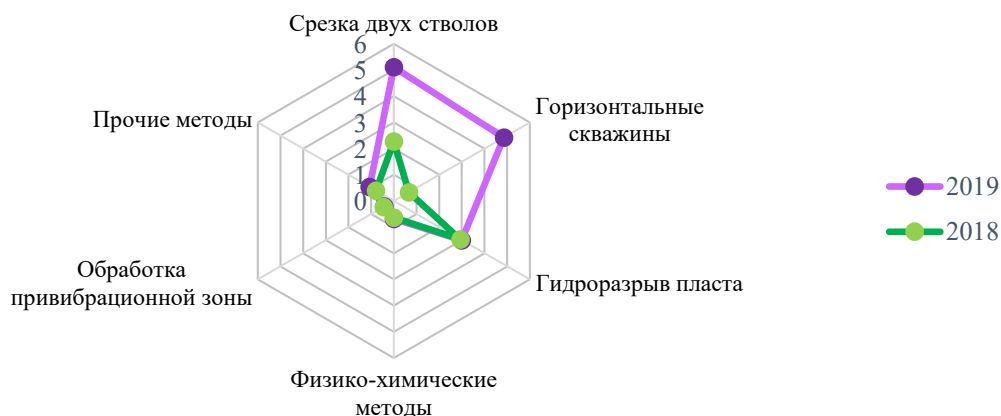
Таблица 2 Среднестатистическая характеристика результатов применения потоко-регулирующих технологий на месторождениях РФ [7]

Успешность работ, %	Дополнительная добыча нефти на одну операцию, тыс. т.	Средний прирост дебита нефти на одну скважину, т/сут.	Продолжительность эффекта, суток	Средний прирост отборов нефти на одну скважину-операцию, т/мес.
69-86	0,6-5,7	0,3-3,0	650	60-230

В настоящее время ПАО «ЛУКОЙЛ» проводит большую работу по внедрению современных технологий повышения изъятия углеводородов на месторождениях Западной Сибири, а также использует технологические инновации, позволяющие интенсифицировать работу скважин, что дает возможность компании ежегодно наращивать объемы дополнительно добытой нефти.

Как уже отмечалось ранее значительный потенциал и перспективы для модернизации технологических режимов нефтегазового комплекса Западной Сибири заложены в передовых инновациях, позволяющих наращивать глубину переработки нефти.

Разница в технологической структуре отечественных заводов по нефтепереработке и предприятий США и Западной Европы определяет заметную разницу в глубине переработки нефти. Как известно, этот показатель характеризуется как технологическими, так и экономическими факторами. В США глубина переработки нефти находится на отметке 96%, в европейских странах составляет 83 - 88%, в России - 71% [8].

Повысить уровень нефтепереработки в России, в целом, и на предприятиях Западной Сибири, в частности, позволит использование современных технологических процессов, в частности построение установок изомеризации, которые дают возможность получения высокооктановых

бензинов, а также установок висбрекинга, благодаря которым в значительной степени увеличивается глубина переработки нефти. Кроме того, в рамках действующих предприятий целесообразно установки термического крекинга реконструировать в установки висбрекинга гудрона и вместо технологически устаревших процессов коксования в кубах построить современные установки замедленного коксования.

С целью производства достаточных объемов высокооктановых бензинов А-95 и А-98 представляется рациональным построить установки изомеризации типа АИ-1508 и установки получения этилтрет-бутилового эфира (ТБЕ). Бензин-изомеризат и ТБЕ как низкокипящие компоненты имеют высокие октановые числа и являются ценными составляющими высокооктановых бензинов. Также отдельный акцент необходимо сделать на том, что значительными возможностями в технологической модернизации нефтегазового комплекса Западной Сибири располагает процесс регенерации отработанных масел, который имеет, кроме экономического, еще и важное экологическое значение.

В таблице 3 представлена сравнительная характеристика эффективности различных технологических процессов в нефтяной отрасли.

Таблица 3 Эффективности переработки нефти с использованием разных технологий в некоторых странах мира, % [8]

Процессы	Мир в целом	США	Западная Европа	Россия	Украина
Каталитический крекинг	16,9	33,2	14	9,5	7,2
Каталитический риформинг	13,3	20,5	15,5	9,3	10,1
Гидрокрекинг	5,5	8,8	3,2	0,6	-
Гидроочистка	50,8	78,2	-	-	15,0
Коксование	5,1	13,7	2,1	0,9	1,8
Алкилирование и изомеризация	4,3	10,9	1,6	0,4	0,5

С экономической точки зрения любые мероприятия по модернизации технологических режимов нефтегазового комплекса Западной Сибири требуют проведения предварительных расчетов, оценки эффективности, определения технологической результативности внедряемых новшеств и инноваций.

В данном контексте предлагаем использовать следующую универсальную модель:

$$E = (Z - Y_2) \cdot H'_2 - (Z - Y_1) \cdot H'_1$$

где Z - средневзвешенная биржевая цена единицы продукции (без НДС и ренты), денежные единицы;

H'_1 - товарная добыча продукции до внедрения новых технологий, натуральные единицы;

H'_2 - товарная добыча продукции после внедрения новых технологий, натуральные единицы;

Y_1 - себестоимость единицы товарного объема продукции до

использования модернизированного оборудования, денежные единицы;

Y_2 - себестоимость единицы товарного объема продукции после использования модернизированного оборудования, денежные единицы.

Таким образом, подводя итоги, отметим, что на сегодняшний день существует широкий спектр разных технических решений и инновационных разработок, позволяющих модернизировать технологические режимы нефтегазового комплекса. Каждое мероприятие по модернизации и совершенствованию производственных процессов на месторождениях Западной Сибири перед внедрением и использованием должно проходить прогностическую оценку эффективности и технологической результативности.

Использованные источники:

1. Давыдова Е.С., Пятницкая Г.Р., Скоробогатов В.А., Соин Д.А. Запасы, ресурсы и перспективы промышленного освоения ачимовского газонефтеносного комплекса севера западной Сибири // Научно-технический сборник Вести газовой науки. 2019. №4(41). С. 121-133.
2. Кааров Ж.З. Анализ эффективности применения методов увеличения нефтеотдачи пластов со сложным геологическим строением // Colloquium-journal. 2020. №6-2(58). С. 20-22.
3. Хартуков Е.М. Экономика нефтедобычи // Финансовая экономика. 2020. №8. С. 108-120.
4. Fundamentals of enhanced oil recovery methods for unconventional oil reservoirs / Dheiaa Alfarge, Mingzhen Wei, Baojun Bai. Amsterdam: Elsevier, 2020. 361 p.
5. Models for optimum decision making: crude oil production and refining / edited by Katta G. Murty. Cham: Springer, 2020. 286 p.
6. Solarin, Sakiru Adebola An investigation of long range reliance on shale oil and shale gas production in the U.S. market // Energy: the international journal. 2020. Volume 195; pp 102-106.
7. Яценко И.Г. Особенности свойств арктической трудноизвлекаемой нефти Сибири // Химия в интересах устойчивого развития. 2019. Т. 27. №1. С. 105-113.
8. Models for optimum decision making: crude oil production and refining / Katta G. Murty, editor. Cham, Switzerland: Springer, 2020. 81 p.
9. Mark J. Kaiser Petroleum refining: technology, economics, and markets. Boca Raton: CRC Press, 2019. 109 p.

Малышева Д.Е.
студент
Оренбургский государственный университет
г. Оренбург

**МЕСТО ИНСТРУМЕНТОВ ПРОГРАММНО-ЦЕЛЕВОГО
БЮДЖЕТИРОВАНИЯ В МЕХАНИЗМЕ РЕАЛИЗАЦИИ
МЕЖБЮДЖЕТНЫХ ОТНОШЕНИЙ В СУБЪЕКТЕ РОССИЙСКОЙ
ФЕДЕРАЦИИ**

Аннотация: Статья посвящена определению места государственных программ и национальных (региональных) проектов в межбюджетных отношениях. Цель статьи – проанализировать взаимосвязь инструментов программно-целевого бюджетирования и инструментов межбюджетного перераспределения. Результатом проведенного исследования стала схема механизма организации межбюджетных отношений с использованием инструментов программно-целевого бюджетирования.

Ключевые слова: межбюджетные отношения, программно-целевое бюджетирование, государственные программы, межбюджетные трансферты.

Malysheva D.E.
student
Orenburg State University
Orenburg

**THE PLACE OF PROGRAM-TARGET BUDGETING TOOLS OF
ORGANIZATION OF INTERGOVERNMENTAL RELATIONS`
MECHANISM IN THE SUBJECT OF THE RUSSIAN FEDERATION**

Annotation: The article is devoted to determining the place of government programs and national (regional) projects in intergovernmental relations. The purpose of the article is analyze the correlation between program-target budgeting tools and intergovernmental relations tools. The result of the research was a scheme of a mechanism for organizing intergovernmental relations using program-target budgeting tools.

Keyword: intergovernmental relations, program-target budgeting, government programs, intergovernmental transfers.

На современном этапе реформ в бюджетной сфере всё более весомое значение приобретают инструменты программно-целевого бюджетирования. Бюджеты всех уровней бюджетной системы Российской

Федерации практически полностью построены на распределении расходов по государственным программам и национальным (региональным) проектам, в рамках которых, в том числе, предусмотрено взаимодействие между публично-правовыми образованиями разного уровня. Отношения между публично-правовыми образованиями регулируются законодательством о межбюджетных отношениях, что обуславливает взаимосвязь между инструментами организации межбюджетных отношений и инструментами программно-целевого бюджетирования.

Межбюджетные отношения являются одним из решающих факторов, влияющих на социально-экономическое развитие как страны в целом, так и отдельно взятых регионов. От эффективности и целесообразности распределения обязанностей и финансовых ресурсов для их выполнения между бюджетами, зависит возможность государства выполнять свои функции, а также обеспечивать население на всей территории страны бюджетными услугами надлежащего качества.

Статья 6 Бюджетного кодекса Российской Федерации определяет межбюджетные отношения, как взаимоотношения между публично-правовыми образованиями по вопросам регулирования бюджетных правоотношений, организации и осуществления бюджетного процесса [1, ст. 6]. Данное определение касается как отношений между Федерацией и регионами, так и отношений между регионами и муниципальными образованиями.

Главным принципом всех межбюджетных отношений остается принцип субсидиарности, планирующий децентрализацию полномочий, которые могут быть выполнены наиболее качественно и полно на региональном или местном уровне [2, с. 115].

Выделяют следующие инструменты межбюджетного перераспределения:

- дотации – на обеспечение выполнения собственных обязательств публично-правового образования перед населением (так как не имеют целевой направленности, следовательно, распределяются публично-правовым образованием по своему усмотрению);

- субсидии – на софинансирование выполнения обязательств публично-правовых образований по совместным полномочиям;

- субвенции – на финансирование выполнения обязательств публично-правовых образований по переданным полномочиям.

Основная идея программно-целевого бюджетирования заключается во взаимной увязке затрат и результатов на всех этапах бюджетного процесса, а ключевые задачи, решаемые в рамках данного подхода, направлены на повышение социальной и экономической эффективности расходов, достижение лучших результатов при меньших затратах [3, с. 1214].

Управление расходами при применении метода программно-целевого бюджетирования на практике также осуществляется через инструменты. К ним относятся государственные программы, федеральные целевые программы, ведомственные целевые программы, а также в 2018 году появились новые инструменты, такие как национальные и региональные проекты [4, с. 3].

Государственная программа – это система мероприятий (взаимоувязанных по задачам, срокам осуществления и ресурсам) и инструментов государственной политики, обеспечивающая в рамках реализации ключевых государственных функций достижение приоритетов и целей государственной политики в сфере социально-экономического развития и безопасности.

Государственная программа включает в себя федеральные целевые программы, подпрограммы, содержащие, в том числе, ведомственные целевые программы и отдельные мероприятия органов государственной власти.

Инструменты программно-целевого бюджетирования непосредственно связаны с организацией межбюджетных отношений, так как формируются с учетом взаимодействия федерального центра с регионами и муниципальными образованиями путем перечисления финансовых ассигнований. При этом формирование целевых показателей осуществляется с учетом расходных полномочий разных уровней власти.

Современные реалии обуславливают необходимость внедрения инструментов программно-целевого бюджетирования в механизм межбюджетных отношений, так как достичь общенациональных целей можно только при вовлечении органов государственной власти на всех уровнях управления.

Вследствие возрастания значимости программно-целевого бюджетирования, приобретает важность контроль целевого исполнения средств. Ориентация на конечный результат позволяет более эффективно планировать и исполнять бюджетные расходы. При этом финансирование в рамках инструментов программно-целевого бюджетирования происходит путем выделения из бюджета субсидий, которые являются инструментами горизонтального регулирования в рамках межбюджетных отношений.

Для того чтобы определить, какую роль играют инструменты программно-целевого бюджетирования в механизме организации межбюджетных отношений, проведем анализ отчетов по исполнению бюджета за 2017-2019 гг. на примере Оренбургской области.

Бюджет Оренбургской области формируется и расходуется преимущественно в программном формате. С 2017 по 2019 гг. процент расходов бюджета, исполненных в рамках реализации государственных программ, составлял от 98,74% до 99,1% от общего объема бюджетных расходов. При анализе отчета об исполнении областного бюджета

Оренбургской области в рамках реализации приблизительно половины государственных программ было предусмотрено взаимодействие между публично-правовыми образованиями разного уровня:

- в 2017 году из 25 госпрограмм - 14;
- в 2018 году из 26 госпрограмм - 13;
- в 2019 году из 26 госпрограмм - 12.

При исполнении государственных программ из вышестоящих бюджетов нижестоящим бюджетам выделяются целевые средства – субсидии и субвенции. Кроме того, дотации на выравнивание бюджетной обеспеченности муниципальных образований также предоставляются бюджетам в рамках подпрограммы «Повышение финансовой самостоятельности местных бюджетов» государственной программы «Управление государственными финансами и государственным долгом Оренбургской области».

При анализе отчетов об исполнении областного бюджета Оренбургской области были выделены межбюджетные трансферты по всем разделам расходов бюджета, которые предоставлялись бюджетам городских округов и муниципальных районов. Полученные результаты, а также структура межбюджетных трансфертов представлены в таблице 1.

Таблица 1 – Анализ структуры межбюджетных трансфертов местным бюджетам Оренбургской области за 2017-2019 гг. [5]

в млн. рублей

Показатель	2017	2018	2019	Удельный вес, в процентах		
				2017	2018	2019
Межбюджетные трансферты местным бюджетам, всего	21 166,60	23 644,79	30 606,50	100	100	100
из них:						
Трансферты местным бюджетам, предоставляемые в рамках непрограммных расходов	80,75	80,78	94,50	0,38	0,34	0,31
Трансферты местным бюджетам, предоставляемые в рамках госпрограмм	21 085,85	23 564,01	30 512,00	99,62	99,6 6	99,69
в том числе:						
дотации	3 759,07	5 738,93	9 839,88	17,83	24,3 5	32,25
субсидии	3 037,32	2 781,65	3 958,15	14,40	11,8 0	12,97
субвенции	14 289,46	15 043,43	16 713,97	67,77	63,8 4	54,78

Межбюджетные трансферты местным бюджетам Оренбургской области из областного бюджета практически в полном объеме предоставляются в рамках реализации государственных программ. Исключение составляет субвенция на осуществление переданных полномочий Российской Федерации на государственную регистрацию актов гражданского состояния, которая составляет от 0,31 до 0,38% от общей величины межбюджетных трансфертов местным бюджетам.

На основании всего представленного выше, считается целесообразным представить следующую схему организации межбюджетных отношений в субъекте Российской Федерации и определить в ней место инструментов программно-целевого бюджетирования (рисунок 1).



Рисунок 1 - Схема организации межбюджетных отношений в субъекте Российской Федерации с использованием инструментов программно-целевого бюджетирования¹⁴⁰

Рассматривая межбюджетные отношения с позиции выравнивания финансовых возможностей муниципальных образований, выделяем элементы, относящиеся к вертикальному и горизонтальному выравниванию. Вертикальное выравнивание в большей степени относится к доходам муниципальных образований, в то время как горизонтальное выравнивание отражается по расходам вышестоящего бюджета. При этом к непрограммным расходам относятся до 1,5% всех расходов субъекта РФ.

¹⁴⁰ Составлено автором

Таким образом, можно сделать вывод, что на современном этапе развития межбюджетных отношений инструменты программно-целевого бюджетирования играют важную роль в процессе горизонтального выравнивания бюджетов. В то же время, практика организации межбюджетных отношений на всех уровнях бюджетной системы служит основанием для наиболее полной реализации целей, на достижение которых направлены государственные программы и национальные (региональные) проекты.

Использованные источники:

- 1 Российская Федерация. Бюджетный кодекс Российской Федерации [Электронный ресурс]: [принят 31 июля 1998 г. №145-ФЗ] // Консультант Плюс: справочно-правовая система. – Режим доступа: http://www.consultant.ru/document/cons_doc_LAW_19702/
- 2 Смагина, М.Н. Проблемы и перспективы совершенствования системы межбюджетных отношений в Российской Федерации // М. Н. Смагина, Г. Т. Мукенге, Социально-экономические явления и процессы. – Тамбов: Тамбовский гос. университет им. Г. Р. Державина. - 2017. – С. 115-121
- 3 Мастеров А.И. Программно-целевое бюджетирование как инструмент стимулирования экономического роста в России // Финансы и кредит - 2018. - №5 (773). – С. 1211-1228
- 4 Исакова А. Р. Содержание и инструменты программно-целевого управления бюджетными расходами // International scientific review. - 2015. - №3
- 5 Отчеты об исполнении областного бюджета Оренбургской области [Электронный ресурс] – Министерство финансов Оренбургской области. – Режим доступа: <http://minfin.orb.ru/отчеты-об-исполнении-бюджета/>

*Мамажоновна З.К.
ассистент
кафедра факультетской терапии
Хужамбердиев М.А.
профессор
кафедра факультетской терапии
Кодирова Г.И.
доцент
кафедра факультетской терапии
Юлдашева С.Л.
ассистент
кафедра факультетской терапии
Андижанский государственных медицинский институт
Узбекистан, Андижан*

**ОЦЕНКА КАЧЕСТВА МЕДИЦИНСКОЙ ПОМОЩИ ПРИ
АРТЕРИАЛЬНОЙ ГИПЕРТОНИИ СРЕДИ СОТРУДНИКОВ
UZ-AVTO MOTORSB АНДИЖАНСКОЙ ОБЛАСТИ**

Аннотация: Дана оценка активности симптоадреналовой системы и определены типы индивидуальной устойчивости к профессиональной деятельности промышленном предприятий, соответствующие состоянию малой, умеренной и сильной напряженности. Данные типы отражают картину адекватной адаптации человека к воздействию отрицательных факторов экстремальной деятельности и состояние напряженности в условиях реальной действительности.

Ключевые слова: симптоадреналовая система, артериальная гипертензия, кардиоваскулярная заболевания.

*Mamazhonova Z.K.
assistant
of the department faculty therapy
Khuzhamberdiev M.A.
professor
of the department faculty therapy
Kodirova G.I.
docent
of the department faculty therapy
Yuldasheva S.L.
assistant
of the department faculty therapy
Andijan State Medical Institute*

ASSESSMENT OF THE QUALITY OF MEDICAL CARE FOR ARTERIAL HYPERTENSION AMONG EMPLOYEES UZ-AVTO MOTORS IN ANDIJAN REGION

Resume. An assessment of the activity of the sympathoadrenal system is given and the types of individual resistance to the professional activity of industrial enterprises corresponding to the state of low, moderate and strong tension are determined. These types reflect a picture of a person's adequate adaptation to the impact of negative factors of extreme activity and a state of tension in real life conditions.

Key words: sympathoadrenal system, arterial hypertension, cardiovascular disease.

Актуальность. В западных странах распространенность АГ составляет 25–35 % населения. В возрасте старше 60 лет доля лиц с МС составляет 42–43,5%. В целом в США от него страдают примерно 47 млн. граждан [3]. Общее число взрослых, страдающих от синдрома, было оценено в 22%, при этом уровень соматического неблагополучия среди людей в возрасте 20–29 лет составил 6,7%, среди 60–летних – 43,5%. Распространенность АГ среди мужчин – 24%, среди женщин – 23,4% [2,4].

Одними из наиболее главных факторов внешней среды, определяющими функциональное состояние организма человека, является характер питания и уровень его физической активности. В настоящее время среди важнейших аспектов исследования гигиены, наряду с нарушениями питания, можно выделить проблему гиподинамии, которая играет существенную роль в развитии широко распространенных заболеваний: атеросклероз, ишемическая болезнь сердца, ожирение и другие [3,5].

В связи с этим проблема рационального питания входит в число кардинальных вопросов гигиены, от решения которых зависит понимание многих механизмов пластического и энергетического обеспечения организма человека в зависимости от режима двигательной активности, лежащих в основе профилактики вышеперечисленных грозных заболеваний [1,3].

На современном этапе развития проблемы гуморальной регуляции рационального питания при различных физических нагрузках большую роль сыграли представления ведущих ученых о нейро-гормональной регуляции симпато-адреналовой системы [4].

Цель исследования. Цель проведенной работы заключалась в изучении роли характера питания в регуляции функционального состояния симпато-адреналовой системы при интенсивной мышечной деятельности и

в условиях повышенной двигательной активности организмасреди сотрудников UZ-AVTO MOTORS в андижанской области.

Материал и методы исследования. В ретроспективное исследование была включена информация о выполненных мероприятиях медицинской помощи среди 62 пациентов с АГ (43 мужчин и 19 женщин), которые работали UZ-AVTO MOTORS в Андижанской области.

Результаты исследования. Результаты вычисления клинических индикаторов в изучаемой когорте пациентов с АГ за 2018–2019 гг. представлены на рис. 1–6. На протяжении почти всего периода с 2018 по 2019 г. на хорошем уровне находилось выполнение мероприятий по контролю уровня физической активности (рис. 2), курения, веса и питания. Однако если оценивать общую результативность данных мероприятий, то эффективными у большинства пациентов их можно признать только для физической активности (большинство пациентов имели достаточный уровень физической активности в течение всех лет).

В начале исследуемого диапазона дат (2018 г.) из исследуемой когорты пациентов (по состоянию на 2019 г. — 62 человека) только 17 лиц имели установленный диагноз «АГ» и находились на диспансерном наблюдении. Однако у части пациентов качество медицинской помощи не было оценено из-за недостаточной полноты имеющихся в первичной документации клинических данных. Охват изучаемой когорты пациентов клиническими индикаторами в разные годы значительно варьировал, К 2019 г. полнота данных в амбулаторных картах по всем клиническим параметрам, необходимым для вычисления индикаторов, была достаточна у 72,6–87,1% пациентов.

Остальные мероприятия имели несколько меньшую эффективность: к 2018–2020 гг. несколько увеличилась доля курильщиков; доля лиц с повышенной массой тела практически не снижалась в течение всего периода, несмотря на проводимую просветительскую работу; подавляющее большинство пациентов с АГ продолжали питаться нерационально, несмотря на разъяснения по особенностям диеты при АГ. Контроль холестерина и контроль АД остаются ключевыми «проблемными» составляющими медицинской помощи пациентам с АГ в ЦСМР.

Результаты работы имеют практическое значение для выяснения особенностей обмена катехоламинов в связи с нарушением питания и гиподинамией в генезе атеросклероза, ишемической болезни сердца, ожирения и других обменных заболеваний. Зависимость функционального состояния симпато-адреналовой системы от характера поступающей пищи может быть положено в основу профилактики вышеперечисленных заболеваний.

Вывод. Таким образом, верификация диагноза АГ может быть сведена к проблеме критериев этого синдрома. Отталкиваясь от принятой гипотезы МС, как о самостоятельной нозологической форме, нужно диагностировать

это заболевание во всех тех случаях, когда у пациента имеются признаки любого из синдромообразующих заболеваний (АГ, ИБС, и/или СД 2 типа), в явной или скрытой форме.

Соответственно, дифференциальный диагноз МС должен проводиться между перечисленными заболеваниями, как формами МС, и соответствующими синдромами, как проявлениями неких иных заболеваний (симптоматические АГ, наследственные дислипидемии и т. п.), что определит пути профилактики и патогенетически обоснованной метаболической терапии.

Использованные источники:

1. Дубова Л.И. Определение содержания глюкозы в слюне глюкозооксидантным методом как показателя психоэмоционального напряжения в стоматологии / Л.И. Дубова // Лабораторное дело. — 1990. — № 4. — С. 70-71.
2. Малов Ю.С. Взаимосвязь уровней кортизола и тестостерона в крови и слюне / Ю.С. Малов, В.А. Карлов, А.К. Кучмин // Клиническая лабораторная диагностика. — 1993. — № 2. — С. 10-14.
3. Терентьев В.П. Особенности функционирования симпато-адреналовой системы у больных артериальной гипертензией с различными вариантами ремоделирования левого желудочка при его гипертрофии / В.П. Терентьев, Е.В. Белова, Б.Я. Зонис // Рос. кардиол. журнал. — 2001. — № 4. — С. 39-42.
4. Bristow M.R. β -Adrenergic receptor blockade in chronic heart failure / M.R. Bristow // Circulation. — 2000. — Vol. 10. — P. 558-569.
5. Hines P.S. Novel epinephrine and cyclic cAMP -mediated action on VCAM/Lu dependent sickle (SS) RBC adhesion / P.S. Hines, Q. Zen, S.N. Burney [et al.] // Blood. — 2003. — Vol. 101 (8). — P. 3281-3287.

*Мамонтова В.М.
студент*

*ВСФ ФГБОУ ВО РГУП
г. Иркутск*

*Кувалдин В.Д.
студент*

*ВСФ ФГБОУ ВО РГУП
г. Иркутск*

*Улмасов М.А.
студент*

*ВСФ ФГБОУ ВО РГУП
г. Иркутск*

*научный руководитель: Власова Е.Л., к.п.н.
доцент*

КУЛЬТУРА МУНИЦИПАЛЬНОГО ПРАВА

Аннотация. В данной статье рассмотрена правовая культура деятельности органов местного самоуправления. Проанализированы проблемы, возникающие у муниципальных служащих при рассмотрении вопросов местного значения, запросов граждан муниципальных образований и возможные способы совершенствования правовой культуры в сфере местного самоуправления.

Ключевые слова: правовая культура, органы местного самоуправления, муниципальный служащий, права граждан, местное самоуправление.

*Mamontova V. M.
student*

*VSF FGBOU VO RSUP
Irkutsk*

*Kuvaldin V. D.
student*

*VSF FGBOU VO RSUP
Irkutsk*

*Ulmasov M. A.
student*

*VSF FGBOU VO RSUP
Irkutsk*

*scientific supervisor: Vlasova E. L., Ph. D.
Associate Professor*

CULTURE OF MUNICIPAL LAW

Annotation. In this article, the legal culture of the activities of local self-government bodies is considered. The problems that arise in municipal employees when considering issues of local importance, requests of citizens of municipalities and possible ways to improve the legal culture in the field of local self-government are analyzed.

Keywords: legal culture, local self-government bodies, municipal employee, citizens ' rights, local self-government.

Законность, приоритет прав человека, его прав и свобод, обеспечение защищенности его публичных интересов являются основными ценностями и принципами в правовом государстве. Для формирования гражданского общества необходимо высокий уровень правовая культура, правового воспитания и правосознания от граждан государства, в том числе от муниципальных органов местного самоуправления и их должностных лиц.

В некоторой степени уважение к закону и положительное отношение к позитивному праву формируется в сознании общества, основываясь на функционирование органов местного самоуправления, деятельность которых основывается на таких принципах, как принцип справедливости, гуманизма и свободы личности.

Проблемными вопросами в развитии правовой культуры общества являются не совершенствование правотворческой деятельности, в также принятие важных для населения нормативных правовых актов без учета его мнений и т.п. Для устранения этих вопросов требуется теоретическая разработка данных проблемных вопросов, целью которой является переоценка сложившихся установок сознания муниципальных служащих для построения и дальнейшего развития правового государства. [1]

Права граждан могут быть нарушены не только при исполнении нормативных правовых актов, но и при предоставлении соответствующих государственных и муниципальных услуг, но это не означает, что это обусловлено умышленным или недобросовестным действием со стороны государственных и муниципальных органов. Причиной нарушения прав могут быть условия реализации, которые закреплены в том или ином нормативном правовом акте, которые никаким образом не связаны с коррупционными действиями или прямым нарушением закона. На возможность нарушения прав граждан влияет недостаточный уровень правовой культуры правотворческих и правоприменительных органов.

Так как эффективное функционирование системы местного самоуправления находится во взаимосвязи с достижением высокого уровня правовой культуры муниципальных служащих, что отражается на их профессионализме, уважении прав и свобод граждан и закону.

Муниципальный служащий должен придерживаться следующих правил:

1) должен осознавать и крайне терпимо относиться к злоупотреблению полномочиями;

2) не может и не должен использовать свое служебное положение для оказания влияния на деятельность других государственных и негосударственных органов, их должностных лиц, государственных служащих, в том числе граждан при решении вопросов личного характера ни при каких условиях;

3) если эти правила были нарушены как проявление неуважения к правам человека, то должно последовать неукоснительное наступление юридической ответственности; [2]

4) действия должны исключать несправедливость, негуманность в отношении граждан.

Муниципальный служащий – это человек, который является:

- образцом с точки зрения профессионализма;
- обладающий безупречной репутацией;
- способствующий формированию в аппарате муниципального образования благоприятного морально-психологического фона;

- от поведения, которого придерживается муниципальный служащий, как и во время исполнения служебных обязанностей, так и за их пределами зависит авторитет органа местного самоуправления с точки зрения граждан. [3]

Для повышения правовой культуры должностных лиц органов местного самоуправления и депутатов местного уровня власти существует множество различных форм и способов, например, тематические семинары, круглые столы по наиболее важным и проблемным вопросам, по распространенным вопросам в случаях нарушения прав населения, создание методических положений по подготовке муниципальных правовых актов и административных регламентов предоставления муниципальных услуг и т.д. Таким образом, требуется регулярная, взаимосвязанная и хорошо скоординированная работа в данном направлении. [4]

Также можно организовать обучение муниципальных служащих органов местного самоуправления, а именно повышение квалификации, что требует законодательного закрепления финансирования, обязательное прохождение повышения всеми депутатами муниципального образования, создание отбора на разные уровни обучения в зависимости от особенностей их работы, установление единого образовательного стандарта для лиц, работающих в органах местного самоуправления. Также необходимо совершенствование реального действующего кадрового резерва, что является на сегодняшний день достаточно актуальным.

В муниципальных образованиях можно организовать онлайн-консультирование по наиболее важным для населения вопросам с

обработкой вопроса в течение одного дня, в том числе вопросы в обязательном порядке должны рассматриваться дистанционно. Для этого необходимо создание call-центров по приему и обработке запросов от граждан, с последующим их рассмотрением экспертами и юристами в области местного самоуправления. Также создание специального информационного портала муниципального образования, с помощью которого можно информационно взаимодействовать с вышестоящими органами федерального уровня.

Необходимо обратить внимание на то, что большая часть прав и свобод граждан реализуется на местном уровне, так как в органы местного самоуправления чаще всего обращаются граждане с проблемными вопросами, поэтому от этого зависит организованность работы по обеспечению прав и свобод граждан в муниципальных образованиях, в том числе уровень законности действий муниципальных органов власти. Наряду с этим в соответствии со ст. 18 Конституции РФ права и свободы человека определяют смысл деятельности законодательной и исполнительной власти, в том числе местного самоуправления. [5]

Как известно Федеральным законом № 131 «Об общих принципах организации местного самоуправления в РФ» установлена двухуровневая система организации муниципальной власти, которая привела к созданию множества муниципальных образований, увеличению органов местного самоуправления и численности муниципальных служащих. [6]

Вследствие этого власть приблизилась к населению, но при этом требуется постоянная потребность в правовом обучении органов и повышении квалификации, когда бюджетных средств недостаточно, особенно это касается поселенческого уровня. Это сказывается на качестве подготавливаемых правовых актов. Поэтому гражданам бесплатно оказываются услуги юридической помощи, и очень даже успешно и эффективно адвокатскими сообществами и «Ассоциацией юристов России». В данном случае муниципальные служащие являются такими же гражданами как все, но наделенные дополнительными полномочиями и ответственностью в отношении граждан. Дальнейшее развитие профилактики данной темы приведет к повышению правовой культуры и граждан, которые получают муниципальные услуги, в том числе и должностных лиц, которые предоставляют подобную услугу, и считается наиболее эффективным способом защиты прав и свобод граждан. Таким образом, граждане учатся правильно отстаивать свои права, а должностные лица учат действовать законно. [7]

Также повышение социальной ценности права поможет в преодолении неграмотности граждан, при помощи правового просвещения, повышения правовой культуры муниципальных служащих.

В первую очередь, муниципальные служащие являются субъектами правотворческой и правоприменительной деятельности. В правотворчестве

низкий уровень правовой культуры проявляется в том, что на уровне муниципальных правовых актов появляются коррупционные факторы, которые подрывают веру в право, снижается уровень уважения к праву и муниципальной власти, появляются определенные социальные группы в муниципальных образованиях, которые убеждают граждан в пренебрежении, игнорировании прав и свобод человека, неуважении права муниципальными органами, в результате чего, это ведет к тому, что резко снижается авторитет муниципальных органов. Для недопущения вышеперечисленных факторов необходимо ужесточить требования к кандидатам на должности муниципальных служащих, дать возможность населению оценивать эффективность деятельности органов местного самоуправления и муниципальных служащих.

Таким образом, можно сделать вывод о том, что правовая культура населения через деятельность органом местного самоуправления в свою очередь способствует созданию развитого гражданского общества, так как при должном уровне правовой культуры создаются условия для эффективной правоприменительной и правотворческой деятельности и эффективного функционирования органов местного самоуправления. Стоит отметить, что необходима потребность в повышении уровня правовой культуры муниципальных служащих.

Использованные источники:

1. Конституция Российской Федерации (принята всенародным голосованием 12.12.1993) (с учетом поправок, внесенных Законами РФ о поправках к Конституции РФ от 30.12.2008 № 6-ФКЗ, от 30.12.2008 № 7-ФКЗ, от 05.02.2014 № 2-ФКЗ, от 01.07.2020 № 11-ФКЗ) // Собрание законодательства РФ от 01.07.2020. – № 31. – ст. 4398. – Ст. 8. [Электронный ресурс] – режим доступа: http://www.consultant.ru/document/cons_doc_LAW_28399/c07038c724cae52fe849aad193a0eac08bda5f93 (дата обращения: 14.12.2020).
2. Федеральный закон от 06.10.2003 № 131-ФЗ (ред. от 09.11.2020) «Об общих принципах организации местного самоуправления в Российской Федерации». [Электронный ресурс] – режим доступа: http://www.consultant.ru/document/cons_doc_LAW_44571 (дата обращения: 13.12.2020).
3. Алешкова Н.П. Правовая культура органов муниципальной власти как способ обеспечения соблюдения конституционных прав граждан // Вестник Сургутского государственного университета. – 2015. – с. 6-7. [Электронный ресурс] – режим доступа: https://www.elibrary.ru/download/elibrary_26293582_38290841.pdf (дата обращения: 13.12.2020).
4. Ефименко Е.Н. Совершенствование правовой культуры муниципальных служащих // Вестник Уральского финансово-юридического института. – 2015. – с. 17. [Электронный ресурс] – режим доступа:

https://www.elibrary.ru/download/elibrary_26223675_79742257.pdf (дата обращения: 14.12.2020).

5. Зимина С.Ю. Правовая культура муниципальных служащих: проблемы и перспективы развития // Правовая культура. – 2016. – с. 111. [Электронный ресурс] – режим доступа: https://www.elibrary.ru/download/elibrary_26193963_31517770.pdf (дата обращения: 13.12.2020).

6. Терентьева К.С. Соотношение правовой культуры и правосознания в сфере деятельности органов местного самоуправления // Аprobация. – 2015. – с. 61-62. [Электронный ресурс] – режим доступа: https://www.elibrary.ru/download/elibrary_21015067_90544564.pdf (дата обращения: 12.12.2020).

*Маруфова З.
Тошкент шаҳар Яшнобод туман
204-мактаб ўқитувчиси*

ШАРҚОНА ГЎЗАЛЛИК ТАСВИРИДА ЎСИМЛИК НОМЛАРИНИНГ РОЛИ

Аннотация: мақолада шарқ шеърлари, хусусан Лутфий ижодиётида гўзаллик концептининг вербаллашуви ҳақида сўз боради. Маъшуқа гўзаллигини ифодалашда ўсимлик номларининг қўлланилиши, бадий тасвир воситаларининг юзага чиқиши жараёнида лексик бирликлар ўртасидаги боғланишларнинг лексик-семантик, когнитив-прагматик асослари таҳлил қилинади.

Калит сўзлар: концепт, ўсимлик, субъектив баҳо, гўзаллик, лексик-семантик майдон, вербаллашув, байт.

*Marufova Z.
teacher
204-school
Yashnobod District of Tashkent City*

THE ROLE OF PLANT NAMES IN THE IMAGE OF SHARGANA BEAUTY

Annotation: The article deals with the verbalization of the concept of beauty in oriental poetry, especially in Lutfi's work. The use of plant names in the expression of the beauty of the mistress, the lexical-semantic, cognitive-pragmatic bases of connections between lexical units in the process of emergence of means of artistic image are analyzed.

Keywords: concept, plant, subjective evaluation, beauty, lexical-semantic field, verbalization, bayt.

Шарқ адабиётида маъшуқа гўзаллигини тасвирлашда ўсимлик номларидан ҳам кенг фойдаланилган. Масалан, ёрнинг юзини гулга, қад-қоматини сарв дарахтига, лабини ғунчага, пистага, сочларини сумбулга, ёноқларини лолага, киприкларини майсага ўхшатиш орқали жозоба ифодалаш анъаналари мавжуд бўлган. Бу ўхшатишлар, албатта, маълум бир мотивацияга, лексемаларнинг лексик-семантик майдонига кирувчи семалар туташувига асосланган.

Бадий тасвирларда кўп қўлланилувчи писта меваси, асосан, ёр оғзининг кичиклигини ифодалаш учун хизмат қилган. Аммо Лутфийнинг

қуйидаги байтида пистага ҳажмдан ташқари ҳолат ифодаси ҳам юкланганини кўриш мумкин:

*Ҳайратда қолиб писта огиз очти-ю, қолди,
Мажлисда чу огзинг соридин кечти ҳикоят.* [1-44]

“Шоирлар ёр оғзини пистага ўхшатадилар. Лутфий тасвиридаги маъшуқа оғзи ҳақида сўз кетган экан, писта оғзини очганча қолибди. Демак, бу маъшуқа оғзи пистадан ҳам кичик экан-да?!” [3-102]. Пистанинг оғизга қиёсланишида “одам+ўсимлик” концептосферасига кирувчи “шакл” ҳамда “ҳолат” концептларининг компонентлари ўзаро туташади. Яъни, ҳар иккала концептга тегишли бўган “кичик” ва “очик” семалари субъект тафаккуридаги тасаввурни вербаллаштиради. Шу билан бирга шоирнинг гўзал ёр ҳуснига берган эмоционал-экспрессив баҳосини ифодалайди. Писта меваси нафақат мумтоз, балки замонавий адабиётда ҳам ёр оғзининг кичиклигини ифодаш учун қўлланади (*Ўтди йиллар, ўчмади дилда шўх истакларим, Эгма қош, писта даҳан, кўзи фаттондан умид. Мухтор Худойқулов*) [2].

*Олма янгоқинг кўргач, мен банда нечук ўлмай!
Бодом кўзи фитна, писта даҳани нозук* [1-142].

Юқоридаги байтда ҳам ёрнинг оғзи ҳажм жиҳатдан пистага ўхшатилса, кўзи шаклан бодомга қиёсланади.

*Эй дўстларим, оҳу кўзин кўрмайин ўлсам,
Зинҳор, сочинг тобутим узра қора бодом,* [1-173]

Оҳу, яъни кийикнинг кўзи қоп-қора ва шахло эканлиги билан шарқ халқларининг миллий-маданий тафаккурида энг чиройли кўз сифатида ассоциациялашган. Шунингдек, кўз шаклининг бодом шаклига ўхшаб кетиши ҳам бизга маълум. М.Раҳматованинг фикрича, “гўзаллик” концептининг тилда воқеланишида ... халқнинг этник хусусиятига хос *табиат ҳодисалари, зоонимлар, ўсимликлар дунёси антропонимлар, таом номлари, диний антропонимлар, историзмлар, услубий хос сўзлар ва ижтимоий* мавзуларга оид лисоний бирликларнинг универсал ҳамда миллий-маданий хусусиятларининг концептуал изоморфик (муштарак) ва алломорфик (фарқли) жиҳатлари исботланган” [4-8].

Келтирилган байт чин маънодаги тасаввуфий ошиқона мисралар бўлиб, бу ерда ҳам ранг, ҳам шакл ўхшашлиги асосида гўзаллик концепти юзага чиқарилган. Шоир тафаккурида **кўз** ва **бодом** лексемаларининг бирламчи маъноларидаги ранг(қора) ва шакл(кўзсифат) белгилари қайта ишланиб, “қора бодом” метафорик бирикмасида мужассам этилади. Адабиётшунос олим М.Абдулхайрнинг таъкидлашича, Алишер Навоий шеърлятида “*бодом - поэтик образ, ирфоний рамз ҳисобланади*”, шунингдек, поклик, комиллик, қаноатни ифода этувчи тимсол ҳамдир. “Шоир ўз шеърлярида поэтик образ тимсоли сифатида бодом сўзини такрор ва такрор қўллаган. Гўё шоир бир комил инсоннинг ўсиб-улғайганидан то

сўнги манзилига кузатиб қўйгунига қадар бодом тимсолидан санъаткорона фойдаланган:

*Чун қора бодом тобут узра расмедур қадим,
Кўз жанозам сари солким, сенсизин бўлдум қатил.* [7]

Лутфий ва Навоий шеърларидан келтирилган ҳар икки мисолда ҳам қора бодомни тобут устига сочиш ҳолатини кўрамыз. Айтиш мумкинки, "қора бодом" бирикмаси нафақат ранг ва шаклни ифодаловчи бирлик, балки чуқур ботиний тасаввуфий тимсол сифатида ҳам Гўзаллик концептининг вербаллашувига хизмат қиляпти.

Гўзаллик ифодалашнинг энг сермахсул шарқона усулларида бири маъшуқа юзини гулга нисбат беришдир.

Лутфий ҳам замондош шоирлари каби ёр жамолини таърифлашда гул, лола, насрин, бинафша, нилуфар, анор(нор) сингари ўсимлик номини билдирувчи лексемалардан кенг фойдаланган.

*Ул оразу рухсор ила зулфи, энги лола,
Ойдинда ётур гул уза бир ҳинду узола* [1-249].

Байтда ёрнинг оппоқ юзи, қизил ёноқлари атрофидан тушган зулфи ойдинда гуллар ичида ётган ҳиндуга қиёсланган. Юзининг оқлиги ва ёноқларининг қизиллиги "ойдин" ҳамда "лола" лексемалари воситасида берилиб, гўзал метафорик тасвир яратилган. Лола ўсимлиги субъект онгида "қизиллик" ва "чиройлилик" белгисини билдиргани сабабли ёр ёноғини ушбу гулга қиёслаш орқали у ўз эстетик баҳосини ифодалайди. Қуйидаги байтда **ранг** ҳамда **ҳид** белгиси одам ва ўсимликка оид лексемаларнинг ўзаро семантик боғланишига асос бўлади:

*То юзунгнинг васфини Лутфий битти, дафтари —
Булди рангину насими гул келур авроқдин* [1-204].

Яъни ёр гўзаллиги битилган дафтарлар гул рангига кириб, улардан гул ҳиди келиши айтилади.

Бу тасвирни лингвистик аспектда қуйидаги схема орқали ифодалаш мумкин:

одам + гул $\xrightarrow{\text{ранг}}$ ҳид, $\xrightarrow{\text{ранг}}$ ёқимли ГЎЗАЛЛИК

Хулоса қилиб айтганда, мумтоз адабиётимизда Гўзаллик концептининг унсурларини ташкил қилувчи *чиройли, ёқимли, жозибадор, ширин, хушбўй, завқ берувчи, жалб этувчи, бенуқсон, тоза* каби тушунчаларни ўсимликлар воситасида ифодалаш анъана тусига кирган бўлиб, шоирларнинг гўзаллик ҳақидаги тасаввурларини вербаллаштиришда аҳамияти катта бўлган.

Фойдаланилган адабиётлар:

1. Лутфий. Девон. Фафур Фулом номидаги нашриёт-матбаа ижойи уйи. Тошкент- 2012
2. <https://ziyouz.uz/uzbek-sheriyati/uzbek-zamonaviy-sheriyati/muxtor-xudoyqulov/>

3. Баҳром Жалилов. Диний-маърифий мавзуларнинг бадиий адабиётдаги талқини. Тошкент – 2010 <http://uz.denemetr.com/docs/768/index-34857.html>
4. Раҳматова М.М. Инглиз, ўзбек ва тожик миллий маданиятида “гўзаллик” концептининг лисоний хусусиятлари. Филология фанлари бўйича фалсафа доктори (PhD) диссертацияси автореферати. Бухоро – 2019
5. Ўразбоев А., Курбанова С. Буюк ипак йўли туғавий бирликлар йўлаги сифатида. “Буюк ипак йўлида умуминсоний ва миллий қадриятлар: тил, таълим ва маданият” халқаро илмий-амалий конференция материаллари. Самарқанд-Шанхай, 2016.
6. https://uz.wikipedia.org/wiki/Guli_sumbul
7. "Қашқадарё" газетасининг расмий веб-сайти 3 декабрь, пайшанба. 2020 йил

*Махмудов Б.М.
ассистент
Холбоев Д.Ж.
ассистент*

*Наманганский инженерно-технологический институт
Узбекистан, Наманган*

ГЕЛИО КОЛЛЕКТОРНЫЕ УСТРОЙСТВА И ГРУППИРОВКА

Аннотация: Обсуждается проблема создание полезных для населения коллекторов. Поскольку использование солнечного коллектора очень рентабельно, солнечный коллектор вырабатывает столько энергии в течение своего срока службы, что покрывается в несколько раз больше, чем стоимость изготовления устройства. На сегодняшний день правительство дало возможность расширить создание коллекторов, приносящих пользу населению.

Ключевые слова: солнечные коллекторы, тепловая энергия, солнечные водонагреватели, фотоэлектрические панели.

*Mahmudov B.M.
assistant
Holboev D.Zh.
assistant*

*Namangan Engineering Technological Institute
Namangan, Uzbekistan*

SOLAR COLLECTOR DEVICES AND GROUPING

Annotation: The problem of creating collectors useful for the population is discussed. Since the use of a solar collector is very cost-effective, the solar collector generates so much energy during its lifetime that it covers several times more than the cost of manufacturing the device. To date, the government has made it possible to expand the creation of collectors that benefit the population.

Key words: solar collectors, thermal energy, solar water heaters, photovoltaic panels.

На сегодняшний день потребность в росте населения и количество энергии, необходимой для удовлетворения его потребностей, резко увеличились. Однако в результате резкого сокращения этих источников энергии на всей планете возникает энергетический кризис. Это связано с резким сокращением использования невозобновляемых источников энергии - источников сухого и жидкого топлива. В результате на Земле происходит

резкое изменение температуры, учащение различных стихийных бедствий. Кроме того, экологическая проблема, возникающая в результате использования этих источников энергии, - загрязнение воздуха острыми токсичными веществами.

Человечество нуждается в возобновляемых источниках энергии для предотвращения глобальных энергетических и экологических проблем, упомянутых выше. Это водопроводная, ветровая, ядерная, солнечная и биогазовая энергия. Сегодня гелиофизики всего мира проводят исследования в области практического использования солнечной энергии, которую можно использовать в любой точке планеты.

Первая модель солнечного коллектора была создана в конце 18 века швейцарским ученым Горацио Соссюром - устройство, состоящее из стеклянного и деревянного ящика со слоем внутри, обладающим свойством нагрева. В этот момент ученый понял, что это «маленький, дешевый и простой». Такие устройства начали использовать на практике в конце 19 века для нагрева горячей воды в Южной Калифорнии. Началось производство простого солнечного коллектора в виде резервуара для воды, покрытого черной краской, установленного на деревянном ящике, накрытом закрытым стеклом, обращенным к солнцу. В таких коллекторах вода вечером не была горячей, приходилось ждать следующего дня, пока она нагреется. В 1909 году в Калифорнии Уильям Бейли создал современный коллектор квартир. В этом случае бак, наполненный водой, отделен от устройства. К концу 1940-х годов промышленность по производству солнечных коллекторов достигла своего пика в южных штатах Калифорния и Флорида. Вскоре после этого потребление электроэнергии и газа, стоимость производства горячей воды упали, а производство солнечных коллекторов прекратилось.



Рисунок 1. (а) и (б) Схематическое изображение обычного солнечного коллектора.

Второй этап производства солнечных коллекторов относится к 1970-м годам. Когда разразился мировой нефтяной кризис и цены на энергоносители взлетели, многие страны мира, включая США, Японию, Австралию и Средиземноморье, начали использовать солнечные батареи. Налажено производство в количестве 'р.

В 1950-х годах острая нехватка энергии в Израиле достигла такого уровня, что вечером правительство приняло закон о прекращении подачи горячей воды. С тех пор в стране развивается производство солнечного оборудования для производства горячей воды. К 1967 году 20% населения страны использовали солнечные коллекторы. Во время энергетического кризиса 1970-х годов парламент принял закон, требующий, чтобы в каждом новом доме была солнечная система отопления. Сегодня 85% энергии, потребляемой домашними хозяйствами в этой стране, обеспечивается солнечными коллекторами. Количество вырабатываемой в них энергии составляет 3% от энергоснабжения страны. Это означает, что в стране проживает 2 миллиона человек в год. баррелей нефти были сохранены.

К 2000 году рост цен на энергоносители открыл новую фазу эксплуатации и производства солнечных коллекторов. К началу 2010 г. по всей планете было установлено 150 ГВт солнечных коллекторов, за исключением солнечных бассейнов (рис. 1.2) и воздушных коллекторов. Солнечные коллекторы мощностью более 30 ГВт устанавливаются каждый год, и сегодня общая мощность солнечных коллекторов в мире вырабатывает более 250 ГВт тепловой энергии, и эта цифра продолжает расти. В частности, в Китае в 2012 году общая площадь солнечных коллекторов составила 145 млн м², а общий объем вырабатываемой ими тепловой энергии превысил 100 ГВт. Если мы сравним это, Его мощность в четыре раза превышает мощность всех атомных электростанций в России вместе взятых. Интересно, что 15 лет назад в Китае почти не было солнечных коллекторов.

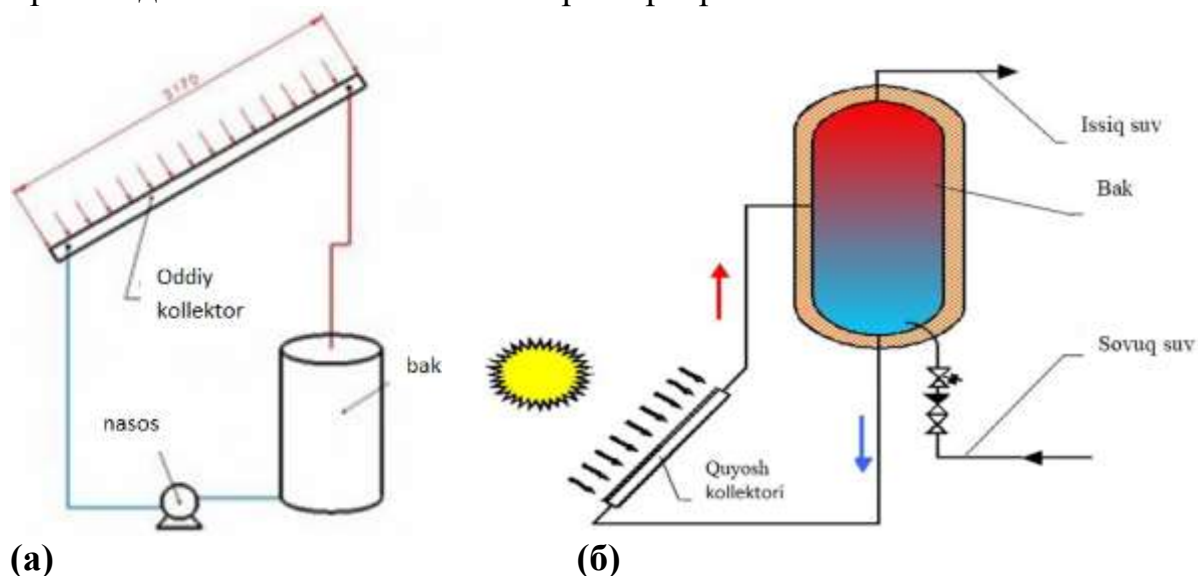

Рисунок 2. Схема обогрева бассейна с помощью солнечного коллектора.

Поскольку использование солнечного коллектора очень рентабельно, солнечный коллектор вырабатывает столько энергии в течение своего срока службы, что окупается в несколько раз больше, чем стоимость сборки устройства. На сегодняшний день правительство дало возможность расширить создание коллекторов, приносящих пользу населению. Поскольку использование солнечного коллектора очень рентабельно, солнечный коллектор вырабатывает столько энергии в течение своего срока службы, что окупается в несколько раз больше, чем стоимость сборки устройства.

На сегодняшний день солнечные коллекторы стали самым эффективным устройством в использовании солнечной энергии. Если фотоэлектрические панели используют 14-18% получаемой солнечной энергии, то эффективность солнечного коллектора достигает 70-80%.

В зависимости от температуры мы рассматриваем солнечные коллекторы следующих типов.

Использованные источники:

1. Михеев М.А., Михеева М.М. Основы теплопередачи. -М.: Энергия, 1977.
2. Теплотехнический справочник /Под.общ.ред.В.Н.Юренева и П.Д.Лебедева. -М.: Энергия, 1976.
3. Ю.Вукалович М.П.»Новиков И.И. Техническая термодинамика. -М.: Энергия, 1968
4. М. Тулкинов, Ш. Сайпиддинов, Метод улучшения коэффициента мощности в однофазной сети// Экономика и социум №12(67) 2019 https://iupr.ru/osnovnoy_razdel__12_67__2019/
5. С.Султонов, М.Камалидинов, Мобильная электростанция «солнце-ветер» в перспективе// Экономика и социум №12(67) 2019 https://iupr.ru/osnovnoy_razdel__12_67__2019/
6. Б.Махмудов, Х. Абдуллаев, Конвейер устройство для сушки фруктов. // Экономика и социум №12(67) 2019 https://iupr.ru/osnovnoy_razdel__12_67__2019/
7. Ражабов И.Т, Шююсупов Ш, Фотогальванические характеристики и коэффициент неидеальности фотоВАХ// Экономика и социум №12(67) 2019 с

*Махмудов О.Т.
соискатель
Термезский государственный университет*

ЗАРУБЕЖНЫЙ ОПЫТ ОПРЕДЕЛЕНИЯ РЕЙТИНГА КОММЕРЧЕСКИХ БАНКОВ

Аннотация: В статье рассматриваются сущность и особенности финансовой устойчивости коммерческих банков. Исследованы методы оценки финансовой устойчивости и особенности ее использования на основе факторов, влияющих на финансовую устойчивость в рейтинговой системе. Также были изучены методики рейтинговой оценки, используемые в банковской практике развитых стран. Приведены выводы и рекомендации по совершенствованию системы рейтинговой оценки.

Ключевые слова: банк, финансовая устойчивость, инвестор, активы, капитал, рейтинг, рейтинговая деятельность, рейтинговые агентства, рейтинговая оценка.

*Makhmudov O. T.
applicant
Termez State University*

FOREIGN EXPERIENCE IN DETERMINING THE RATING OF COMMERCIAL BANKS

Annotation: The article discusses the essence and features of the financial stability of commercial banks. The methods of assessing financial stability and the features of its use based on factors affecting financial stability in the rating system were investigated. The rating assessment methods used in the banking practice of developed countries were also studied. Given the conclusions and recommendations for improving the bank rating system.

Key words: bank, financial stability, investor, assets, capital, rating, rating activities, rating agencies, rating assessment.

В условиях финансовой нестабильности постоянно меняются приоритеты коммерческих банков. Это требует принятия необходимых мер для обеспечения финансовой безопасности банков. Потому что стабильная работа коммерческих банков может меняться в результате влияние внутренних и внешних факторов, в том числе от деятельности ненадежных партнеров (банков, инвестиционных компаний, других финансовых институтов).

Также во взаимоотношениях между банками, если один из них не является финансово устойчивым, то есть, что они не выполняют свои обязательства в полном объеме и в течение определенного периода времени, процесс отрицательно сказывается на финансовых показателях коммерческих банков-партнеров.

Одним из основных видов устойчивости коммерческих банков является их финансовая устойчивость [1,24]. На снижение финансовой устойчивости влияют такие факторы, как частые кризисы в мировой экономике, вызывающие неспособность оценивания потенциальных рисков и отсутствие необходимых механизмов для борьбы с ними. Снижение финансовой устойчивости создается в случаях как увеличения количества банков с дефицитом финансовых ресурсов, снижении рентабельности банковских активов, уменьшении суммы депозитов и повышении депозитных ставок, неудовлетворительном качестве общего кредитного портфеля. Требуется аналитической оценки финансовой устойчивости и научного обоснования ее оптимальных способов влияющих на деятельность коммерческих банков в условиях изменяющихся внешних факторов. Поэтому методы оценки финансовой устойчивости банков постоянно совершенствуются. В связи с этим изучение практического опыта зарубежных стран и его применение в банковской практике нашей страны характеризуется своей актуальностью. Для комплексного анализа финансовой устойчивости необходимо аналитические материалы (ее финансовое состояние и показатели), позволяющие получать достоверную, полную и оперативную информацию о банках. Такая информация включает, прежде всего, нормативные, плановые, бухгалтерские и статистические данные. Также важно знать методологию оценки финансовой устойчивости в процессе анализа финансовой устойчивости коммерческих банков. Методология - это совокупность правил и методов, основанных на установленных принципах исследования банковской деятельности, направленных на точное изучение различных объектов анализа, что помогает полностью оценить финансовую устойчивость.

Методы оценки финансовой устойчивости коммерческих банков, применяемые в западных странах, можно разделить на следующие группы [2,274]:

- рейтинговые системы (PATROL, ORAP, CAMELS) [3, 275];
- системы коэффицентного анализа ((BAKIS);
- комплексные системы оценки банковских рисков (RATE, RAST);
- статистические модели (FIMS, SAABA);
- индексный метод и т.д. [2, 275].

Составление рейтинга - один из наиболее эффективных способов продемонстрировать уровень доверия к банковской системе или конкретному банковскому учреждению. Рейтинг банков - это система оценки их деятельности по совокупным показателям и характеристикам

[2,59].Цель рейтинга - определить уровень надежности банка. В большинстве случаев для составления рейтинга используются данные банковского баланса, отчетов о прибылях и убытках. Таким образом, рейтинг банков представляет собой сложную систему комплексного исследования и сравнения их основных финансовых показателей, которая характеризуется важностью использования рейтинговых систем государственными органами при выполнении надзорных функций в отношении банков и независимых рейтинговых агентств. Рейтинги регулирующих органов не публикуются в прессе, но используются в качестве источника принятия решений для предотвращения банкротства и обеспечения уверенности вкладчиков в стабильности банковской системы. В странах с развитыми рыночными отношениями рейтинг банков - это в первую очередь средство демонстрации инвестиционной привлекательности банка, свидетельствующей о способности менеджеров работать профессионально и прибыльно в такой сложной сфере, как финансовый бизнес. Метод рейтинговой оценки в основном охватывает важные показатели, такие как достаточность капитала, качество активов, ликвидность, прибыльность, анализ управления и чувствительности банков к рыночному риску. Для каждой из этих характеристик устанавливаются рейтинговые баллы в соответствии с уровнем активности финансового учреждения, и эти баллы выражаются количественно. Посредством рейтинга он помогает отбирать банки по их положению среди кредитных организаций. Основное внимание в рейтинге уделяется анализу финансовых результатов и качества управления. В таблице №1 перечислены группы пользователей рейтинговых данных коммерческих банков, отражающие заинтересованные стороны и их цели в обеспечении высокого рейтинга банков.

Пользователи рейтинговых данных коммерческих банков¹⁴¹.

№	Заинтересованные стороны	Ожидаемая выгода от рейтинга
1.	Акционеры	Заинтересованность в адекватности инвестируемого капитала, увеличение рыночной стоимости банка
2.	Сотрудники банка	Заинтересованность в постоянном трудоустройстве в данном банковском учреждении, высоких зарплатах, реализации социальных гарантий со стороны работодателей
3.	Центральный банк	Обеспечение надежности банковской системы, внутренняя и внешняя защита интересов клиентов и инвесторов.
4.	Клиенты	Уверенность банков выполнят свои обязательства перед ними
5.	Аудиторские фирмы и рейтинговые агентства	Соблюдение интересов граждан и инвесторов, достоверность публикуемого отчета
6.	Налоговые органы	Стабильные налоговые поступления в бюджет
7.	Прочие коммерческие банки, небанковские кредитные организации, лизинговые компании и другие финансовые учреждения	Рентабельность совместных проектов, гарантия исполнения обязательств
8	Государство	Эффективная деятельность финансово-кредитной системы в стране, повышение имиджа страны

Следует отметить, что оценку учетливости банков могут проводить ведущие международные рейтинговые агентства, в том числе известные Standard & Poor's (S&P), Moody's, Fitch и другие компании [4,371]. Поэтому в настоящее время важно изучить национальные методы, используемые при оценке устойчивости коммерческих банков, которые используются в развитых странах. В большинстве случаев зарубежные методы оценки учетливости коммерческих банков имеют схожие свойства. Рейтинги - это эффективный инструмент для регулярного анализа деятельности банков. Для получения комплексного рейтинга деятельности банка необходимо проанализировать широкий спектр регламентированных отчетных документов и провести дополнительные исследования в кредитной организации.

Одна из самых популярных рейтинговых систем в мире - рейтинговая система CAMELS, используемая американскими банковскими регуляторами. Он состоит из шести неотъемлемых компонентов: достаточность капитала, качество активов, факторы управления,

¹⁴¹Разработано автором.

прибыльность, ликвидность и оценка рисков. Каждый компонент этой системы оценивается по пятибалльной шкале и является окончательным показателем на основе своих значений. Однако эта система в основном основана на субъективных оценках, поэтому конечный результат во многом будет зависеть от профессионализма экспертов.

Целью французской рейтинговой системы ORAP является выявление значительных проблем в банках на основе оценки всех компонентов риска, связанных с их деятельностью, с использованием данных количественных и качественных показателей. Рейтинговая система ORAP включает 14 показателей, которые разделены на пять групп: пруденциальные коэффициенты, балансовая и забалансовая деятельность, рыночный риск, выручка и критерии качества. Преимуществом данной системы является высокая скорость процесса анализа, так как используется мало индикаторов, по которым можно оценить текущее состояние банка.

Одной из самых популярных рейтинговых систем является PATROL, которую Банк Италии использует с 1993 года. Целью рейтинговой системы является удаленный анализ финансового состояния кредитной организации (на основе регламентированных отчетов банков) и определение показателей, необходимых для установления контроля над банками. В ходе анализа исследуются достаточность капитала, прибыльность, качество кредитов, организационные аспекты и ликвидность. Преимущества этой системы - скорость анализа текущего состояния банка и эффективность оценки. Однако результаты анализа лишь достоверно отражают текущее состояние банка.

Рейтинги - эффективный инструмент для регулярного анализа деятельности банков, но для ведения рейтинга на регулярной основе требуются регулярные и большие объемы данных. Определение рейтинга банков на определенный период требует анализа широкого спектра регламентированных отчетных документов и дополнительных исследований в кредитной организации.

В ходе нашего исследования были изучены следующие проблемы методического обеспечения рейтинга банков:

- методы и используемая информация применяемые международными и национальными агентствами, закрыта для пользователей;
- неспособность национальных методов быстро адаптироваться к изменяющейся ситуации на финансовых рынках других стран с учетом различий в экономическом развитии между странами;
- множество наличия информации о деятельности коммерческих банков, составляющей банковскую тайну, которая должна быть проанализирована оценщиками;
- различия в законодательстве, регулирующем деятельность коммерческих банков.

- несовершенный общий набор количественных и качественных показателей, используемых для формирования рейтинга;
- отсутствие объективного единого подхода к расчету рейтингов с учетом количественных и качественных показателей;
- рейтинги в основном отражают субъективные оценки аналитиков рейтинговых агентств.

На основании вышеизложенного можно вносить следующие предложения:

- разработать эффективную методологию, применяемую в нашей стране, с использованием передовых методов и практику зарубежного опыта определения рейтингов коммерческих банков;
- усилить взаимодействие науки и банковской практики в подготовке высококвалифицированных аналитиков, изучающих деятельность банков;
- сформировать единую методологическую базу информации, необходимой для рейтинговой оценки;

Вышеперечисленные предложения обеспечат стабильность банковской системы нашей страны и послужат их эффективному функционированию.

Использованные источники:

1. Лаврушин О.И., Мамонова И.Д. Оценка финансовой устойчивости кредитной организации / Лаврушин О.И. – М.: КНОРУС, 2013.
2. Костерина Т.М. Банковское дело / Московская финансово-промышленная академия, М., 2005
3. Чернова, С.А., Алиева, М.Ю., Султанов, Г.С. Основные подходы оценки финансовой устойчивости коммерческих банков // Экономика и предпринимательство. – 2015. – № 12-4 (65-4).
4. Замурагина, К.С. Зарубежная практика оценки финансовой устойчивости банковского сектора // Молодой ученый. – 2016. – №21. – С. 367–371.

Махмудов В.В.
ассистент кафедры физического воспитания и спорта
Ташкентский институт ирригации
и инженеров механизации сельского хозяйства
Ходжанов А.Р.
доцент кафедры физического воспитания и спорта
Ташкентский институт ирригации и инженеров механизации
сельского хозяйства

СОЦИАЛЬНЫЕ ФУНКЦИИ ФИЗИЧЕСКОЙ КУЛЬТУРЫ И СПОРТА

Аннотация: В данной статье говорится о физической культуре - как вид культуры, представляющий собой процесс человеческой деятельности. Поднят вопрос о решении задач, направленных на совершенствование природной основы человека, а также социальной ценности спорта, в которой заключается совокупность наиболее действенных средств и методов физического воспитания, как одну из основных форм подготовки человека к трудовой и другим необходимым видам деятельности.

Ключевые слова: спорт, физическая культура, физическое воспитание, социальная ценность, саморегуляция, процесс.

Makhmudov V.V.
assistant of the Department of Physical Education and Sports
of the Tashkent Institute of Irrigation and Agricultural
Mechanization Engineers
Khodjanov A.R.
docent of the Department of Physical Education and Sports
of the Tashkent Institute of Irrigation and Agricultural
Mechanization Engineers

THE SOCIAL FUNCTIONS OF PHYSICAL CULTURE AND SPORT

Annotation: This article defines and gives information about physical culture - as a kind of culture, which is a process of human activity. The issue of solving problems aimed at improving the natural basis of man, as well as the social value of sports, was raised, which consists of a set of the most effective means and methods of physical education, as one of the main forms of training a person for labor and other necessary activities.

Key words: sport, physical culture, physical education, social value, self-regulation, process.

Физическая культура - это вид культуры, который представляет собой специфический процесс и результат человеческой деятельности, средство и способ физического совершенствования людей для выполнения ими своих социальных обязанностей.

Физическое воспитание - процесс формирования потребности в занятиях физическими упражнениями в интересах всестороннего развития личности, формирования положительного отношения к физической культуре, выработка ценностных ориентации, убеждений, вкусов, привычек, наклонностей.

Спорт - вид физической культуры: игровая, соревновательная деятельность и подготовка к ней, основанные на использовании физических упражнений и направленные на достижение наивысших результатов.

Укрепление здоровья людей, содействие воспроизводству здорового населения и сохранению генофонда страны. Основным показателем физического состояния человека является его здоровье, которое обеспечивает полноценное выполнение человеком всех жизненных функций и форм деятельности в тех или иных конкретных условиях.

В физической культуре, как части общечеловеческой культуры, отражаются в специфической форме общекультурные связи и традиции, единое содержание и функции культуры. Материальная, духовная и физическая культуры взаимно проникают друг в друга, обеспечивая в конечном счете каждая своими средствами реализацию общественного интереса в целостной, гармоничной личности.

При решении задач, направленных на совершенствование природной основы человека, его физической организации, физическая культура, будучи одной из человеческих и социальных ценностей, выступает как культура образа жизни людей, человеческого общества в целом, участвует в реализации главной цели общества - совершенствовании человека.

Физическая культура вносит свой вклад в формировании целостной личности, способной адекватно действовать в многообразном мире, ориентируя человека на разнообразные формы социальной активности.

Поэтому развитое общество объективно заинтересованно в высоком уровне развития физической культуры всего общества и его граждан, в максимальном внедрении ее в их повседневную жизнь.

Физическая культура несет в себе специфически личностную функцию - формирование индивидуального интереса к физическому совершенству как социально и культурно осознаваемой потребности.

Социальная ценность спорта заключается в совокупности наиболее действенных средств и методов физического воспитания, одну из основных форм подготовки человека к трудовой и другим необходимым видам деятельности.

Физическая культура общества воплощает в себе высшие достижения в данной сфере общечеловеческой культуры. Государственно важным

направлением деятельности является организация в стране физического воспитания в различных подразделениях общества, начиная с детских садов - яслей и до производственных образований. Создана государственная система руководства по внедрению различных форм физического воспитания в учебных, военных и производственных подразделениях.

Важную роль в развитии физической культуры и спорта играет целая сеть учебных и научно - исследовательских учреждений, организованных у нас в стране. Они эффективно анализируют и используют передовой опыт других стран и одновременно сами осуществляют поиск новых методик и научных исследований различных явлений физической культуры и спорта.

Наш организм напоминает государство, в котором много клеточных образований, выполняющих множество жизненно важных функций. Координированное их взаимодействие в течении необходимого времени, обеспечивает определенного рода деятельность человека. Для этого необходимо участвующим в процессе клеткам доставить питание и убрать шлаки. Эту функцию в нашем организме исполняет в первую очередь сердечно сосудистая система, а также печень, почки, кишечник и др. органы.

Очень важно, чтобы функциональные клеточные образования нашего организма способны были необходимое конкретное время проявлять свои функции для эффективного выполнения запланированной деятельности в определенных внешних условиях.

Целый ряд современных профессий, которыми овладевают студенты МАИ, предъявляют высокие требования к физической подготовке и связанными с этим способностями человека. Эти профессии имеют свою двигательную специфику, различаются по психофизиологическим характеристикам и условиям труда, они будут предъявлять разные требования к физической подготовленности студентов в будущем.

Ученые объединили с учетом физической тяжести, нервной напряженности и затраты килокалорий все существующие виды труда в четыре группы: 1 - легкий, ненапряженный; 2 - средний, малонапряженный; 3 - тяжелый, напряженный; 4 - очень напряженный.

К первой группе относятся виды умственного труда, включающие работу на счетно - вычислительных машинах и пультах управления, работу корректоров типографий, инженеров заводских отделов, главных конструкторов, главных механиков, работников планового отдела и т.д., характеризующаяся циклом саморегуляции напряжения внимания и мышления. Сюда относятся работники конструкторского отдела, которые разрабатывают новые изделия. Такая деятельность связана с интенсивным участием высших отделов центральной нервной системы, деятельность которой обеспечивается работой таких психических функций, как память, внимание, ассоциативное и логическое мышление.

Для этих работников характерно интенсивное напряжение высших отделов головного мозга, интенсивная концентрация внимания, быстрое его переключение, экстренное принятие решений, оперативное руководство и контроль за их выполнением. Присущий им творческий труд характеризуется повышенной способностью удерживать в памяти сведения, необходимые для создания новых образцов, процессов, быстротой сравнения и анализа исследуемых явлений. Инициативный цикл саморегуляции при умственных видах труда проявляется в концентрации нервных процессов, точности дифференцировок (различий), скорости и точности решения задач, устойчивости внимания и его интенсивности, адекватного реагирования нервных процессов (соблюдение закона силы нервных процессов), скорости восприятия и переработки информации, быстрого краткосрочного запоминания, повышенного нервно - эмоционального состояния.

Использованные источники:

1. Грименко М.Ф. «Целебная сила движений», ФКиС, 4/1991.
2. Матвеев Л.М. «Введение в теорию физической культуры», ФКиС, 1983.
3. Матвеев Л.М., Новиков А.Д., «Теория и методика физического воспитания», изд.2, испр. и доп. (в 2-х т.) ФКиС. М.,1976:
Т-1 - Общие основы и методики физического воспитания;
Т-2 - Специализированные направления и особенности основных возрастных звеньев системы физического воспитания.

*Мелентьева О.А.
студент*

*ФГБОУ ВО «Пермский государственный аграрно-технологический
университет им. академика Д.Н.Прянишникова»
Россия, Пермский край, г. Пермь*

УПРАВЛЕНИЕ КАЧЕСТВОМ ПРОДУКЦИИ НА ПРЕДПРИЯТИЯХ ПИЩЕВОЙ ПРОМЫШЛЕННОСТИ

Аннотация: В данной статье рассмотрено и отражено современное состояние производства продукции на предприятиях пищевой промышленности.

Ключевые слова: управление качеством, международный стандарт системы менеджмента безопасности пищевых продуктов.

*Melentyeva O.A.
student*

*FSBOU "Perm State Agrarian and Technological University named after
academician D.N.Pryanishnikov,"
Russia, Perm Krai, Perm*

PRODUCT QUALITY MANAGEMENT AT FOOD INDUSTRY ENTERPRISES

This article considers and reflects the current state of production at food industry enterprises.

Keywords: quality management, international standard of food safety management system

Под управлением качеством продукции понимаются действия, осуществляемые при ее создании, эксплуатации и потреблении в целях формирования, обеспечения и поддержания заданного уровня качества продукции.

Современное производство продукции существенно отличается от производства нескольких десятилетий назад. Такие изменения наблюдаются как в отечественных, так и в зарубежных компаниях, как в пищевой промышленности, так и в других отраслях.

Ключевым фактором, влияющим на успешность компании, становится качество производимой продукции, следовательно, управление им (качеством продукции) в определенной степени можно рассматривать как управление успехом компании. В связи с этим важную роль в деятельности любого предприятия, нацеленного на развитие и успех, играет

управление качеством, а современные концепции управления качеством и инструменты контроля качества, доказавшие свою эффективность на предприятиях разных стран мира, воспринимаются как руководство к действию и как путь достижения успеха. Как уже было отмечено выше, современный менеджмент качества базируется на философии всеобщего управления качеством TQM, ключевые принципы которого, в свою очередь, отражены в международных стандартах ISO серии 9000.

В основе систем менеджмента качества на базе стандартов ISO серии 9000 лежат семь ключевых принципов, близких к идеологии всеобщего управления качеством TQM:

1. Ориентация на потребителя;
2. Лидерство;
3. Взаимодействие людей;
4. Процессный подход;
5. Улучшение;
6. Принятие решений, основанных на свидетельствах;
7. Менеджмент взаимоотношений.

Еще одним трендом развития современного менеджмента, в том числе и на предприятиях пищевой промышленности, является применение интегрированных систем менеджмента качества. Под интегрированной системой управления качеством принято понимать часть системы общего менеджмента организации, отвечающую требованиям двух или более международных стандартов на системы менеджмента и функционирующую как единое целое.

На сегодняшний день в России и за рубежом практикуется создание интегрированных систем менеджмента, основанных на системах менеджмента качества, экологического менеджмента, менеджмента профессиональной безопасности и здоровья, социального и этического менеджмента.

С 1996 г. стали появляться международные стандарты ISO серии 14000, которые устанавливали системные требования к менеджменту охраны и защиты окружающей среды и сформировали руководство по созданию систем экологического менеджмента (EMS – Environmental Management Systems).

Базовым стандартом экологического менеджмента является международный стандарт ISO 14001:2015 «Системы экологического менеджмента. Требования и руководство по применению», содержащий набор базовых правил, которые применяются организациями для проектирования и внедрения эффективных систем экологического менеджмента.

Еще одной и более актуальной именно для пищевой отрасли областью применения интегрированных систем менеджмента качества является область обеспечения безопасности выпускаемой продукции. Как известно,

пищевая продукция относится к потенциально опасной продукции, т.к. она способна оказывать непосредственное влияние на здоровье и жизнь человека. В связи с этим в пищевой промышленности как в России, так и за рубежом все большую роль играет проблема обеспечения безопасности пищевых продуктов путем снижения рисков производства опасной продукции и повышения гарантий безопасности продукции для потребителей.

Обеспечение стабильности безопасности и качества выпускаемой продукции является основной целью создания различных систем менеджмента. Например, для пищевого предприятия является актуальной и востребованной интегрированная система менеджмента качества, которая сочетает в себе две системы: система менеджмента качества (международные стандарты ISO серии 9000) и система обеспечения безопасности пищевой продукции на базе принципов ХАССП (международные стандарты ISO серии 22000).

Среди множества преимуществ для предприятий пищевой и перерабатывающей промышленности от внедрения системы обеспечения безопасности пищевой продукции на базе принципов ХАССП можно выделить следующие основные пять:

1. Снижение финансовых затрат от возникновения брака за счет изменения подхода к обеспечению безопасности продукции, а также за счет более экономного использования ресурсов для управления безопасностью;
2. Повышение конкурентоспособности за счет появления новых возможностей по освоению новых рынков сбыта и расширению существующих;
3. Создание репутации предприятия как производителя качественного и безопасного продукта питания;
4. Достижение документально подтвержденной уверенности относительно безопасности пищевых продуктов;
5. Реализация системного подхода обеспечения безопасности пищевой продукции, что можно использовать для интеграции с системой менеджмента качества на базе ISO серии 9000.

Использованные источники:

1. Горбашко Е.А. Управление качеством : учебник для ВУЗов / Е.А.Горбашко.3-е изд., перераб. И доп. — Москва: Издательство Юрайт, 2020.-352 с. (Высшее образование). – Текст: непосредственный.
2. Дунченко Н. И. Управление качеством продукции. Пищевая промышленность. Для аспирантов: учебник / Н. И. Дунченко, М. П. Щетинин, В. С. Янковская. — Санкт-Петербург: Лань, 2018.

*Миловидова В.С.
студент магистратуры 3 курса
Московский областной филиал РАНХиГС*

УПРАВЛЕНИЕ РИСКАМИ В СИСТЕМЕ ЗДРАВООХРАНЕНИЯ

Аннотация: В данной статье анализируются подходы к оценке и управлению рисками в здравоохранении, рассматриваются основные этапы риск-менеджмента, риск-ориентированные подходы в медицине. Определяется значение риск-менеджмента в системе здравоохранения.

Ключевые слова: риск-менеджмент, медицина, управление, риск.

*Milovidova V.S.
student of magistracy 3 course
Krasnogorsk Branch of RANEPA*

RISK MANAGEMENT IN THE HEALTHCARE SYSTEM

Abstract: This article analyzes approaches to assessing and managing risks in healthcare, discusses the main stages of risk management, risk-oriented approaches in medicine. The value of risk management in the healthcare system is determined.

Keywords: risk-management, medicine, management, risk.

Управление рисками или риск-менеджмент получило развитие как новое научно-практическое направление в конце XX века в экономически развитых странах в различных сферах человеческой деятельности, в том числе в здравоохранении

Успех управленческой деятельности в здравоохранении во многом определяется уровнем развития основных разделов менеджмента, включающих планирование, управление, контроль и корректировку. Особое место занимает относительно новое направление в управлении современным здравоохранением – риск-менеджмент или управление рисками.

Деятельность организации в сфере здравоохранения невозможна без риска как для медицинского персонала, так и для пациентов. В современном здравоохранении существуют многочисленные медицинские, организационные, управленческие, психоэмоциональные, экономические и другие риски, которые могут привести к нежелательным последствиям. Но в данной сфере риски принимают несколько другое значение, нежели в какой-либо организации другой сферы деятельности.

Применительно к здравоохранению риск можно охарактеризовать как вероятность того, что случится нежелательное событие, или эффект, опасный для здоровья пациента или безопасности медицинского работника. Характерной чертой случайного наступления события является невозможность точно определить время и место его возникновения.

Как и само определение риска, его элементы имеют специфическое значение в области здравоохранения.

Риск-менеджмент в здравоохранении, как относительно новое направление, несет научное обоснование теории и практики управления рисками в системе охраны и восстановления здоровья населения. Приоритетом риск-менеджмента в медицине является контроль качества лечебно-диагностического процесса с целью обеспечения безопасности. Безопасность медицинской деятельности, в свою очередь, зависит от эффективного управления, минимизации и устранения возможных рисков, как со стороны руководителей, так и со стороны исполнителей, определяет результативность работы медицинской организации и включает: •

- Эффективное управление ресурсами и сведение к минимуму вероятности событий, имеющих негативные последствия для пациентов, персонала и аппаратуры.
- Обеспечение соблюдения государственных и ведомственных норм медицинской деятельности.
- Обеспечение финансового благополучия и устойчивого развития учреждения.
- Сведение к минимуму вероятности событий, имеющих негативные последствия для пациентов, персонала и учреждения.
- Минимизацию риска смерти, увечья или болезни для пациентов, сотрудников и посетителей в результате предоставляемых услуг.
- Улучшение результатов диагностики и лечения пациентов.
- Эффективное управление ресурсами.

Общими оценочными составляющими рисков медицинской деятельности являются:

1. Объекты оценки:
 - пациент;
 - медицинский работник;
 - аппаратура и оборудование;
 - окружающая среда (люди, животные, растения, водоемы, воздух, здания и т.п.).
2. Экономическая целесообразность:
 - по отношению к аппаратуре и оборудованию:
 - 1) прибыль от экономии на средствах для обработки и расходных материалах;

2) прибыль от повышения сроков службы аппаратуры, например, благодаря использованию доказано безопасных средств для обработки, применения автоматизированных способов обработки, соблюдению условий хранения и т.п.;

- по отношению к пациенту:

1) безопасность применяемых методик и аппаратуры, в том числе отсутствие рисков передачи инфекций при медицинских манипуляциях и причинения любого вреда пациенту от применения неисправной аппаратуры;

2) сроки постановки диагноза, лечения и реабилитации в зависимости от доступности и качества оказания медицинской помощи;

3) применения доказано эффективных методов диагностики и лечения, организация скрининга и диспансеризации, внедрение малоинвазивных оперативных методик и т.п.;

- по отношению к медицинскому персоналу:

1) качество оказания медицинской помощи, благодаря соблюдению квалификационных требований, постоянному повышению знаний и навыков в системе непрерывного медицинского образования и т.п.;

2) сохранение здоровья медицинского персонала, благодаря использованию малотоксичных и безопасных средств для обработки аппаратуры, правильному размещению приточно-вытяжной вентиляции, нормированию труда и соблюдению графика работы в соответствии с ТК РФ.

3) исключение из процесса медицинской деятельности неблагоприятных факторов рабочей среды, связанных с оплатой труда, психологическим настроением, общей атмосферой в медицинской организации и т.п.;

4) мотивация на профессиональный рост, совершенствование рабочих навыков и пополнение знаний персонала;

3. Ущерб - ухудшение или потеря свойства объекта. Так, если объектом выступает человек, то ущерб может выражаться в виде ухудшения его здоровья, если объектом выступает оборудование, ущерб выражается в выходе его из строя и оценивается, исходя из затрат на ремонт и/или приобретение нового оборудования.

4. Вероятность события - математический признак, означающий возможность рассчитать частоту наступления события (вероятности ущерба) при наличии достаточного количества статистических данных.

5. Случайность события - невозможность точно определить время и место его возникновения.

Эффективности организации управления рисками должна служить классификация рисков. Наиболее полная классификация общих рисков в здравоохранении приведена в работе коллектива кафедры общественного

здоровья и здравоохранения МПФ Первого Московского государственного медицинского университета им. И.М. Сеченова и включает 5 групп рисков:

1. Социально-правовые и экономические.
2. Риски, связанные с управлением.
3. Профессиональные риски.
4. Риски, связанные с угрозой здоровью медицинских работников.
5. Прочие риски (техногенные, пожароопасные, взрывоопасные, и др.).

Риск-менеджмент в здравоохранении включает также анализ комплаенс-рисков, связанных с соблюдением регламентирующих норм и правил, профессиональным взаимодействием руководства и персонала, этикой ведения пациентов, что относится к рискам рабочей среды и может быть выделено в отдельную группу рисков. За последние 20 лет в мире отмечен рост числа медицинских организаций, фокусирующих свою деятельность на внедрении и развитии комплаенс-программ - по общепринятому термину «программ производственного контроля».

За последние 20 лет в мире отмечен рост числа медицинских организаций, фокусирующих свою деятельность на внедрении и развитии комплаенс-программ - по общепринятому термину «программ производственного контроля» (в дословном переводе - «программ соответствия»). Тем не менее, доказательная база большинства этих программ сегодня не является полностью научно обоснованной и поэтому не может быть признана достаточно эффективной.

Использованные источники:

1. Кучеренко, В.З. Организационно-управленческие проблемы рисков в здравоохранении и безопасности медицинской практики / В.З. Кучеренко, Н.В. Эккерт // Вестник Российской Академии Медицинских наук. – 2012. – Т.67, №3. – С.4-9.
2. Мурашко, М.А. Единые подходы к проведению экспертизы качества медицинской помощи / М.А. Мурашко, Ю.А. Кондратьев, Н.О. Матыцин, О.Р. Швабский // Вестн. Росздравнадзора. - 2016. - № 1. - С. 5-9.
3. Прохорова А.А. Развитие антикризисных программ Правительства Российской Федерации с 2009 года // Эффективное Антикризисное Управление. – 2016. – №4. С.
4. Стародубов В.И., Улумбекова Г.Э. Здравоохранение России: сценарии развития // ОРГЗДРАВ: новости, мнения, обучение: журнал для непрерывного медицинского образования врачей. – 2015. – №2. – С.34 – 46.

Михайлов В.С.

студент

ФГБОУ ВО РГАУ-МСХА имени К.А. Тимирязева

Москва

научный руководитель: Алексанов Д.С., к.э.н.

ФГБОУ ВО РГАУ-МСХА имени К.А. Тимирязева

Москва

ОСОБЕННОСТИ ОЦЕНКИ ИНВЕСТИЦИОННЫХ ПРОЕКТОВ ОБНОВЛЕНИЯ ТЕХНОЛОГИИ ПЕРЕРАБОТКИ САХАРНОЙ СВЁКЛЫ

Аннотация: в данной статье исследована процедура инвестиционного анализа проектов по модернизации предприятий свеклосахарного подкомплекса на примере АО «Ульяновский сахарный завод». По результатам исследований определены особенности методологического подхода при оценке инвестиционных проектов по обновлению технологии переработке сахарной свеклы

Ключевые слова: инвестиции, свеклосахарный подкомплекс, инвестиционный анализ, сахар.

Mikhailov V.S.

student

Russian State Agrarian University - Moscow Timiryazev Agricultural

Academy

Scientific supervisor: Aleksanov D.S., Ph.D.

Russian State Agrarian University - Moscow Timiryazev Agricultural

Academy

FEATURES OF EVALUATION OF INVESTMENT PROJECTS UPGRADING SUGAR BEET PROCESSING TECHNOLOGY

Abstract: This article examines the procedure for investment analysis of projects for the modernization of enterprises of the sugar beet subcomplex on the example of JSC "Ulyanovsk sugar plant". Based on the results of the research, the features of the methodological approach were determined when evaluating investment projects to update the technology for processing sugar beet.

Keywords: investments, sugar beet subcomplex, investment analysis, sugar.

Свеклосахарное производство является одной из главных составляющих АПК Российской Федерации. Свекловичный сахар – ценный высоко энергетический продукт питания, обеспечивающий необходимый

баланс углеводов в организме человека. Кроме того, сахар используется в качестве сырья для кондитерской, хлебопекарной, фармацевтической, химической отраслей промышленности. На примере системного анализа свеклосахарного производства (в частности АО «Ульяновский сахарный завод») попытаемся рассмотреть его состояние и перспективы устойчивого экономического роста, что позволит повысить конкурентоспособность отечественной сельскохозяйственной продукции в целом.

АО "Ульяновский сахарный завод" является единственным в области свеклосахарным заводом, построен в 1967 году. Производительность по переработке сахарной свеклы в 2019 году составила 4141,8 тонн сахарной свеклы в сутки, что на 4,38% выше, чем в 2018 году. При этом выработано всего за 2019 год 74 274,90 тонн сахара-песка, тогда как за 2018 - 60 487,35 тонн. [1]

Анализ масштабов производства показывает, что за 2019 год заводом было переработано 455 500,548 тонн сахарной свеклы, за 2018 год - 372 488,814 тонн. В тоже время прибыль от основного вида деятельности – продажи сахара-песка в 2019 году сократилась на 80,5% и составила 35 696 тыс. руб. Данный спад прибыльности деятельности связан с тем, что цены на сахар на протяжении всего 2019 года снизились более чем на 45%, упав до минимума за последние 7 лет. В этой ситуации наиболее чувствительно ощущается влияние таких факторов, как существенный износ основных производственных фондов, что не позволяет использовать эффективные ресурсосберегающие технологии, сокращая себестоимость продукции, а также исключительная ориентированность на единственный продукт – сахар-песок в структуре продаж.

Аналогичная ситуация наблюдается на большинстве из действующих 74 свеклосахарным заводах России.

Суть инвестиционного проекта заключается в строительстве завода по переработке сахарной свеклы в Новомалыклинском районе Ульяновской области. Проектная мощность завода заявлена в 17000 тонн/сутки. По окончании сезона переработки сахарной свёклы запускается выпуск продукции, полученный с помощью глубокой переработки отходов производства - гранулированного жома, минеральных удобрений и биоэтанола.

Задачами инвестиционного проекта являются:

- осуществить переход от экстенсивных энергозатратных технологий в переработке сахарной свеклы и производстве сахара в области к современным мировым технологическим решениям.

- решить демографически-социальные проблемы: создать новые рабочие места, повысить престиж трудоустройства в сфере свеклосахарного производства, подготовить высококвалифицированных специалистов, снизить ежегодно прогрессирующий отток населения из области

- производить сахар в достаточных количествах для обеспечения поставок в близлежащие регионы (Самарская область, Республика Татарстан)

Создание инновационного свеклосахарного завода в Ульяновской области также будет являться показательным предприятием, демонстрирующий рациональный, экологический и общественно-полезный подход к свеклосахарному производству.

Технологическая отсталость существующей технологии выражается как в применении устаревшего оборудования, так и в общей организации производственного процесса. Применение энергозатратных технологий ярко выражено в сушке свекловичного жома в барабанных сушилках продуктами сгорания топлива с высокой температурой, тогда как современным способом реализации данного процесса, используемом, в том числе в европейских странах, является сушка перегретым паром под давлением. Это позволяет сократить выбросы загрязненного отработанного энергоносителя в атмосферу, а также сократить затраты теплоты с 74 мДЖ/100 кг свеклы до 36 мДЖ/100 кг. [2]

Инновационность проекта характеризуется наличием глубокой переработки отходов на сахарном заводе, что приведёт к круглогодичному функционированию завода, и современного оборудования - к снижению необходимых площадей, энергозатрат и времени переработки сырья.

На фоне политики ведущих производителей сахарной отрасли в мире, идёт тенденция к сокращению количества мало- и средне- мощных сахароперерабатывающих заводов в регионах и концентрации производства на небольшом количестве более мощных предприятий. Таким образом, можно сделать предположение, что количество сахарных заводов в ближайшие 5-10 лет в России начнёт сокращаться, в то время как завод в Ульяновской области будет являться центром инновационных технологий Приволжского федерального округа.

В ходе проведения анализа проекта, были выявлены определенные положительные тенденции в отношении вторичной продукции переработки сахарной свеклы. На региональных рынках в РФ существует высокий потенциальный спрос на карбид-амиачные смеси для удобрения почв (КАС). Данный продукт предлагается получать из дефеката – отхода сахарного производства, образующегося в процессе дефекации сахарного сока.

Другое перспективное направление, требующее существенного внимания – производство и сбыт биоэтанола, как отхода от переработки мелассы. Несмотря на то, что идея использование биоэтанола как альтернатива традиционному топливу сейчас ещё не до конца развита, рост доступности данного вида топлива может в том числе послужить импульсом к развитию применения возобновляемых источников энергии.

Смета инвестиционных затрат на первые 2 года проекта представлена в таблице 1.

Таблица 1

Характеристика инвестиционных затрат, тыс. руб.

Наименование показателей	Всего по проектно-сметной документации	1 год				2 год			
		I кв.	II кв.	III кв.	IV кв.	I кв.	II кв.	III кв.	IV кв.
		Капитальные вложения по утвержденному проекту, всего	2744986	379971	241586	326986	383419	432719	322086
в том числе:									
строительно-монтажные работы, всего	176000	29333	29333	29333	29333	25000	15000	14000	4667
включая:									
Строительство 1 очереди свеклосахарного завода	86500	24000	22500	21000	19000				
Строительство 2 очереди свеклосахарного завода	45500					23500	22000		
Строительство 3 очереди свеклосахарного завода	44000							21000	23000
Оборудование, всего	2481000	345253	212253	295253	329253	404919	282753	347353	263966
включая:									
Подготовительное оборудование	239880	145000			40000		16000		38880
Главная производственная линия	1602020	200253	200253	200253	200253	200253	200253	200253	200253
Аппараты для очистки сока	180000				89000	23000	22000	46000	
Технологические установки завершающего цикла	209600		12000	95000		98500		41000	

Оборудования глубокой переработки отходов производства	249500					8316 7	4450 0	9700 0	24833
Приобретение земельного участка, 10 га	2284,7	2284 ,7							
Инженерно-геодезические изыскания	2080,0	1680 ,0				400			
Услуги по монтажу оборудованию, пуско-наладочным мероприятиям и пробному запуску	7200,0			2400		2400		2400	
Транспортные средства	73000,0				2433 3		2433 3		24333
Расходы на проведения аттестации, сертификации и получение разрешительной документации	3420,0	1420 ,0			500				1500
Создание запаса оборотных средств	5967000								59670 00

В связи с тем, что собственных денежных средств предприятия не достаточно для реализации проекта, было принято решение и необходимости его субсидирования.

В целях исполнения мероприятий по реализации проекта предполагается получение государственной поддержки в виде бюджетных средств областного бюджета Ульяновской области в рамках программы предоставления субсидий в целях возмещения части затрат, связанных с промышленной переработкой продукции растениеводства (Постановление Правительства Ульяновской области от 01.06.2015 N 244-П «Об утверждении Правил предоставления хозяйствующим субъектам субсидий из областного бюджета Ульяновской области с целью возмещения части их затрат, связанных с промышленной переработкой продукции

растениеводства»). Предполагаемую субсидию планируется получить в пределах суммы, не превышающей 75 процентов затрат, связанных со строительством объектов. [3]

Особенностью субсидирования в рамках указанной программы является предоставление денежных средств на возмещение уже понесённых затрат, т.е. после фактического расходования на строительство объекта и приобретение оборудования. В результате на осуществление данных операций будет необходимо привлекать заемные средства в первый год проекта, с целью последующего их частичного возмещения субсидией.

Поскольку полученная субсидия на совершенствование производства не сможет покрыть все затраты, необходимые для осуществления проекта, необходимо привлекать дополнительные средства.

Оставшуюся часть денежных средств для инвестирования в строительство сахарного завода предполагается получить у заинтересованных инвесторов. Предполагаемая ставка по займу 20%.

На основании вышесказанного, проект предусматривается осуществлять за счёт собственных средств от существующего производства, за счёт заемных средств и за счет получения государственной субсидии. Всего предусмотрено привлечение инвестиций на его осуществление в размере 9794468 тыс. руб., в том числе: 1044698 тыс. руб. – получение государственной субсидии, 7470529 тыс. руб. – привлечение заёмных средств, 689241 тыс. руб. – высвобожденные оборотные средства со старого производственного объекта, 590000 тыс. руб. – высвобожденные оборотные средства со старого производства.

Таким образом, привлечённые средства окажут влияние на:

- показатели реализуемости проекта – т.е. минимальное накопленное сальдо, в соответствии с которым будут привлечены средства в рамках займа. Без привлечения заемных средств проект не может быть реализован, что связано в том числе с необходимостью прироста рабочего капитал из-за увеличения производственной мощности почти в 4 раза. Тогда как привлечение субсидии не оказывает влияние на показатели реализуемости проекта.

- показатели эффективности проекта – т.е. чистая приведенная стоимость, отражающая финансовую привлекательность проекта. С получением субсидии NPV проекта будет выше, но если субсидия не сможет быть получена по различным причинам (например, изменение регионального законодательства, бюрократические барьеры и т.д.), то проект также будет реализуем. Получение субсидии позволит сократить необходимую сумму займа и реструктурировать другие статьи затрат.

При такой схеме финансирования проект может стать реализуемым и эффективным для инициатора.

Особенностью проектов по модернизации свеклосахарного производства является высокая капиталоемкость основных средств,

необходимость перестройки всех производственных процессов в случае внедрения прогрессивных технологий по переработке отходов. В связи с круглосуточным режимом работы завода в период сахароварения, оборудование значительно изнашивается и после окончания сезона должно подвергаться ремонту и чистке.

Также проблемой модернизации технологии, связанной с заменой основных производственных мощностей, является постепенный переход на новое производство с временным сохранением старой технологии. Т.е. на начальном этапе реализации проекта в период строительства сооружений и монтажа оборудования, производство сохраняется на старом объекте.

По мере завершения строительства очередей объектов завода, к концу второго года осуществляется перенос всех активов на новую производственную площадку, таким образом, что в третьем году реализации проекта переработка осуществляется по новой технологии. В то же время осуществляется получение оборотных средств с закрывающейся площадки и реализация основных средств и земельного участка в связи с её закрытием.

Применив подход и общие правила оценки инвестиционного проекта, установленные "Методическими рекомендациями по оценке эффективности инвестиционных проектов" (утв. Минэкономки РФ, Минфином РФ, Госстроем РФ 21.06.1999 N ВК 477), проект по модернизации свеклосахарного подкомплекса Ульяновской области на базе АО «Ульяновский сахарный завод» оценивается как коммерчески эффективный. [4]

На первом этапе оценки был проведена агрегированная экономическая оценка предлагаемого проекта. Получены сведения об участниках проекта и экономическом окружении. Также предварительно была собрана информация о текущем состоянии отрасли, определена величина спроса в области, а также расширенный круг поставщиков сырья. Предварительно были собраны сведения о зарубежных перерабатывающих центрах, была получена информация о передовом опыте производств, осуществляющих переработку сахарной свеклы. От ведущих производителей перерабатывающей оборудования были получены коммерческие предложения с условиями поставки, монтажа и обучения эксплуатации технологических установок.

Далее был осуществлен выбор схемы и условий финансирования. Предполагается использования государственной субсидии с целью повышения эффективности проекта, однако основной объем привлекаемых средств будет получен в рамках кредита. Были рассчитаны денежные потоки от инвестиционной и финансовой деятельности и дисконтированием приведены к базовому моменту времени.

В итоге представленный проект был признан реализуемым и эффективным и может быть применен к аналогичным производстве. Однако, как и у любого планируемого проекта в связи с ситуацией

неопределенности, существуют определенные риски при реализации данного проекта.

В первую очередь, это риск, с которым столкнулись все производители в свеклосахарной отрасли – снижение цен на сахар на более чем на 40% в 2019 году. Данный риск связан с переизбытком готовой продукции на рынке. В результате производители должны снижать цену реализации и тем самым сокращать рентабельность своего производства.

Второй существенный риск, характерный для комплексных проектов, затрагивающих различные производственные процессы и связи множества контрагентов, существует риск нарушения условия договорных обязательств при поставке высокотехнологичного производственного оборудования. Данные нарушения могут быть как объективными – например, необходимость дополнительной доработки блоков технологической линии в соответствии с индивидуальными требованиями заказчиков, так и субъективными – ошибки в планировании, нарушение логистических цепочек, отсутствие денежных средств для предоплаты по контракту. В результате существует шанс смещения в сроках запуска комплексных процессов, содержащих несколько производственных систем.

Другим возможным риском для данного проекта может быть переполнение регионального рынка производимой продукцией, либо нехватка сырья у местных поставщиков. Данные ситуации могут повлечь высокие логистические издержки, связанные с необходимостью доставки готовой продукции в соседние регионы или закупкой сырья у удаленных поставщиков.

Риски, связанные с персоналом предприятия, должны быть также учтены при реализации проектов с инновационными технологиями. Существует риск отсутствия необходимых компетенций у кадров для работы на импортном высокотехнологичном оборудовании.

Таким образом, основной целью анализа рисков следует считать минимизацию масштаба и вероятности негативных для проекта событий. [5]

Базовые меры по минимизации рисков представлены в таблице 2.

Риски проекта

Риски	Способы минимизирования
Снижение цены реализации на сахар	Введение ресурсосберегающих технологий, автоматизации производства с целью сокращения переменных затрат. Повышение доли побочной продукции в структуре производства.
Недоставка части оборудования	Наличие резервных поставщиков, конкретизация сроков в контрактах, подготовка альтернативного варианта для запуска основного производства с частичной установкой оборудования
Нехватка рынков сбыта или поставщиков сырья	Проведение комплексных маркетинговых исследований, проработка логистических цепочек поставок в соседние регионы, поиск крупно и мелко оптовых поставщиков сырья
Низкий уровень подготовки персонала	Повышение квалификации кадров предприятия, осуществление рекламных мероприятий в областном центре для привлечения специалистов

Данные меры должны носить предупредительный характер, внося оперативные корректировки в план реализации проекта, не дожидаясь негативных последствий.

Использованные источники:

1. Бухгалтерская отчетность АО «Ульяновсксахар», 2019 г.
2. Энергетический анализ технологических режимов жомосушильной установки в тепловой схеме сахарного завода. Статья. А.В. Дранников, Известия вузов. Пищевая технология. №4, 2011.
3. Постановление Правительства Ульяновской области от 01.06.2015 N 244-П «Об утверждении Правил предоставления хозяйствующим субъектам субсидий из областного бюджета Ульяновской области с целью возмещения части их затрат, связанных с промышленной переработкой продукции растениеводства
4. Методические рекомендации по оценке эффективности инвестиционных проектов (Вторая редакция, исправленная и дополненная) (утв. Минэкономки РФ, Минфином РФ и Госстроем РФ от 21 июня 1999 г. N ВК 477)
5. Инвестиционный анализ. Учебник / Д.С. Алексанов, В.М. Кошелев. - М.: РГАУ-МСХА, 2015.

*Мицкевич Н.О.
студент 2 курса
факультет экономики и финансов
УО «Полесский государственный университет»
Республика Беларусь, г. Пинск
научный руководитель: Козловская Е.Е.
преподаватель кафедры банкинга и финансовых рынков
УО «Полесский государственный университет»
Республика Беларусь, г. Пинск*

ДИНАМИКА СТАВКИ РЕФИНАНСИРОВАНИЯ В РЕСПУБЛИКЕ БЕЛАРУСЬ

Аннотация: В данной статье рассматривается основной инструмент денежно-кредитной политики Республики Беларусь – ставка рефинансирования, динамика которой отражена за 2017-2020 годы, а также определена тенденция её изменения.

Ключевые слова: ставка рефинансирования, рефинансирование, процентная политика, кредит, депозит.

*Mitskevich N.O.
student 2nd year
faculty of Economics and Finance
UE "Polessky state University"
Minsk, Republic of Belarus
scientific adviser: Kozlovskaya E. E.
lecturer of the Department of banking and financial markets
UE "Polessky state University"
Minsk, Republic of Belarus*

DYNAMICS OF THE REFINANCING RATE IN THE REPUBLIC OF BELARUS

Abstract: this article discusses the main instrument of monetary policy-the refinancing rate. Its dynamics in the Republic of Belarus for the period 2017-2020 is presented. The trend of changes in the refinancing rate is determined.

Keywords: refinancing rate, refinancing, interest rate policy, credit, deposit.

Процентная политика центрального банка является важным фактором, определяющим стоимость привлекаемых и размещаемых на кредитном рынке ресурсов. Большинство центральных банков проводят

свою денежно-кредитную политику на основе регулирования процентных ставок. Не прибегая к прямому регулированию процентной политики коммерческих банков, центральный банк определяет единство процентной политики в масштабах хозяйства, стимулируя повышение или понижение процентных ставок. К числу ставок, с помощью которых осуществляется регулирование денежного и кредитного рынков в стране, относится ставка рефинансирования [1, с. 438].

Ставка рефинансирования – ставка Национального банка Республики Беларусь, являющаяся базовым инструментом регулирования уровня процентных ставок на денежном рынке и служащая основой для установления процентных ставок по операциям предоставления ликвидности банкам [2, с. 102].

Рефинансирование коммерческих банков может проводиться либо путем прямого краткосрочного кредитования, либо посредством переучета коммерческих векселей. Понижение официальной процентной ставки приводит к удешевлению кредитных ресурсов и увеличению предложения на рынке, напротив, ее повышение – к сжатию денежной масс, замедлению темпов инфляции, но в тоже время – к сокращению объема инвестиций.

Изменение ставки рефинансирования сигнализирует об изменениях в денежно-кредитной политике центрального банка в зависимости от уровня инфляции. Основным объектом, на который воздействует процентная политика центрального банка, во всех развитых странах являются краткосрочные кредиты. Однако посредством регулирования учетной ставки центральные банки воздействуют не только на состояние денежного, но и финансового рынка. Так рост учетной ставки влечет за собой повышение ставок по кредитам и депозитам на денежном рынке, что в свою очередь влияет на уменьшение спроса на ценные бумаги и увеличение их предложение [1, с. 439].

Главными факторами, которые оказывают влияние на формирование ставки рефинансирования в Республике Беларусь, являются: уровень инфляции; ситуация на внутреннем валютном рынке; состояние платёжного баланса; уровень золотовалютных резервов государства; динамика обменных курсов белорусского рубля к иностранным валютам; мировые тенденции на финансовых рынках и др.

За анализируемый период в Республике Беларусь происходили следующие изменения ставки рефинансирования (рис. 1):



Рис. 1. Динамика ставки рефинансирования в Республики Беларусь за период 2017-2020 гг., %

Примечание – Источник: собственная разработка на основе [3].

Согласно данным рисунка 1 за последние 3 года наблюдается тенденция снижения ставки рефинансирования. На протяжении анализируемого периода ставка рефинансирования снизилась на 6,25 процентных пункта, в том числе с 19 апреля 2017 г. по 14 июня 2017 г. – на 1 процентный пункт; с 14 июня 2017 г. по 19 июля 2017 г. – на 1 процентный пункт; с 19 июля 2017 г. по 13 сентября 2017 г. – на 0,5 процентных пункта; с 13 сентября 2017 г. по 18 ноября 2017 г. – на 0,5 процентных пункта; с 18 ноября 2017 г. по 14 февраля 2018 г. – на 0,5 процентных пункта; с 14 февраля 2018 г. по 27 июня 2018г. – на 0,5 процентных пункта; с 27 июня 2018г. по 14 августа 2019 г. – на 0,5 процентных пункта; с 14 августа 2019 г. по 20 ноября 2019 г. – на 0,5 процентных пункта; с 20 ноября 2019 г. по 19 февраля 2020 г. – на 0,25 процентных пункта; с 19 февраля 2020 г. по 20 мая 2020 г. – на 0,75 процентных пункта; с 20 мая 2020 г. по 1 июля – на 0,25 процентных пункта.

Данные изменения ставки рефинансирования произошли из расчёта на повышение деловой активности в Республике Беларусь, т.к. снижение ставки рефинансирования делает кредиты более доступными для субъектов предпринимательства и даёт возможность большему количеству предприятий использовать заемные средства и направлять их на реализацию своих проектов. Однако рост деловой активности возможен только в том случае, если в экономике существует платежеспособный спрос на кредиты, т.е. как на практике будут реализованы данные возможности, будет зависеть от каждого субъекта хозяйствования, работающего в Беларуси. Помимо выше описанного, снижение ставки рефинансирования ведёт к увеличению кредитной активности банков и улучшению их ликвидности, однако рост предложения денег в экономике может привести к ускорению инфляции.

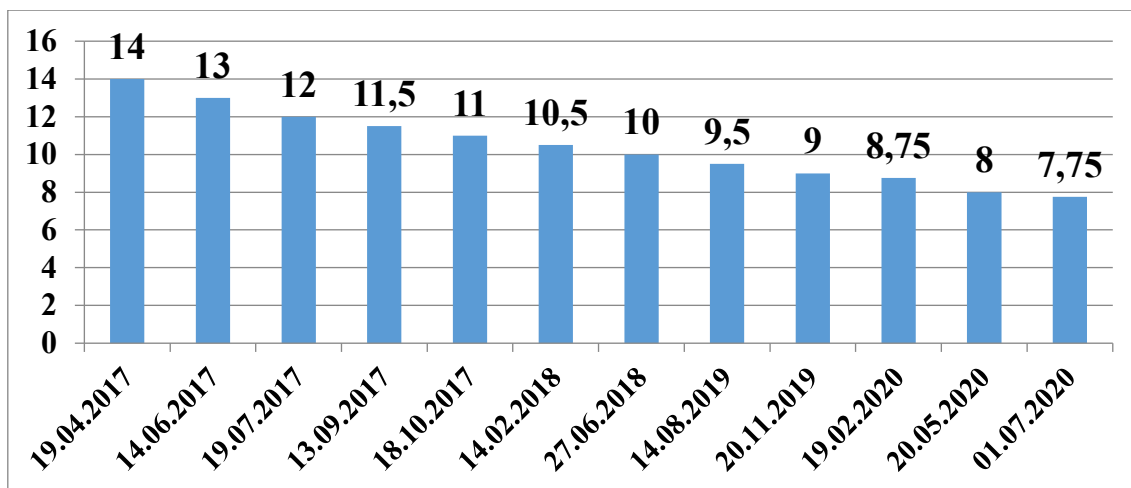
Таким образом, ставка рефинансирования - одни из ключевых инструментов регулирования денежно-кредитного рынка в Республике

Беларусь. Она также представляет собой своеобразный экономический ориентир. Ее ожидаемое значение отражается в разрабатываемых ежегодно основных направлениях денежно-кредитной политики, которые утверждаются Указом Президента Республики Беларусь.

Использованные источники:

1. Деньги, кредит, банки: учеб. / Г.И. Кравцова [и др.]; под ред. Г.И. Кравцовой. – Минск: БГЭУ, 2010. – 527 с.
2. Козловская, Е.Е. Динамика ставки рефинансирования в Республике Беларусь / Е.Е. Козловская // Экономическая модель современности: задачи, проблемы, перспективы: материалы Международной научно-практической конференции, г. Нежин, 6–7 апреля 2017 г. / Нежинский агротехнический институт; ред.: В. С. Лукач (гл. ред.) [и др.]. – Нежин, 2017. – С. 102–103.
3. Ставка рефинансирования [Электронный ресурс] / Национальный банк Республики Беларусь. – Режим доступа: <http://www.nbrb.by/statistics/MonetaryPolicyInstruments/RefinancingRate> – Дата доступа: 25.12.2020.

*Морозов М.К.
студент*

*научный руководитель: Шестопалова Н.С., к.э.н.
Мытищинский филиал МГТУ им. Н. Э. Баумана*

СОВРЕМЕННЫЕ ТЕНДЕНЦИИ ПРЯМЫХ ИНОСТРАННЫХ ИНВЕСТИЦИЙ В МИРЕ

Аннотация. Статья посвящена современным тенденциям прямых иностранных инвестиций в мире. Автор приходит к выводу о наличии структурных изменений в инвестиционных потоках и тенденции к снижению их объема, что объясняется кризисными тенденциями в глобальных торгово-экономических отношениях.

Ключевые слова: инвестиционный климат; международная торговля; международные инвестиции; прямые иностранные инвестиции; транснациональные корпорации.

*Morozov M.K.
student*

*Research advisor: Shestopalova N.S., PhD in Economic sciences
Mytischki Branch of Bauman Moscow State Technical University*

CURRENT TRENDS OF FOREIGN DIRECT INVESTMENT IN THE WORLD

Annotation. The article is devoted to modern trends of foreign direct investment in the world. The author comes to the conclusion that there are structural changes of investment flows and a tendency towards a decrease of their volume, which are explained by the crisis trends in global trade and economic relations.

Key words: investment climate; international trade; international investment; direct foreign investment; transnational corporations.

В мировых торгово-экономических отношениях существенное значение имеет объем и распределение инвестиционных потоков. В том случае, если инвестирование производится в экономику иностранного государства, такие инвестиции являются иностранными. «Прямые иностранные инвестиции, - пишет В. С. Галактионов, - реализуются путём приобретения иностранными инвесторами местного предприятия за границей в форме слияний и поглощений или же создания смешанного предприятия, строительства нового предприятия или франшизы. Но помимо

этого существуют и другие формы прямого инвестирования, такие как приобретения активов за рубежом, инвестиции без вложений в капитал» [2, с. 41].

Теория прямых международных инвестиций была выдвинута Хаймером в начале 1960-х годов, а к концу 1970-х Даннинг окончательно завершил общую теорию ПИИ. Даннинг выделял пять стадий развития страны в потоках ПИИ. На первой стадии страна не привлекает инвестиций из-за существенных инфраструктурных проблем, а последней же стадии страна превращается в чистого экспортера капитала.

При изучении вопроса о об общей теории прямых иностранных (международных) инвестициях следует подчеркнуть два отличия от традиционных международных потоков капитала: первое состоит в том, что лица, осуществляющие ПИИ, могут получить большие выгоды; второе отличие состоит в возможности снижения трансакционных издержек. ПИИ позволяют инвесторам получать прибыль в долгосрочном периоде и осуществлять контроль за деятельностью предприятия.

До 1980-х годов теория ПИИ в основном фокусировалась на компаниях в развитых странах, особенно в США. Считалось, что конкурентные преимущества крупных компаний в развитых странах в основном проистекают из монополии на рынке, дифференциации продукции, высокотехнологичных и крупномасштабных инвестиций и превосходной технологии корпоративного управления. Напротив, компании в развивающихся странах не имеют вышеуказанных преимуществ. Они часто имеют небольшие масштабы инвестиций, низкотехнологичные продукты. Однако после 1980-х годов некоторые ученые стали специализироваться на теории ПИИ в развивающихся странах.

ПИИ являются основной формой долгосрочного движения капитала. Прямые иностранные инвестиции порождают право контролировать деятельность предприятия. В отличие от косвенных инвестиций, инвесторы получают выгоду, участвуя в праве на управление предприятием и контролируя его. Современные ПИИ имеют следующие характеристики: увеличивающийся масштаб; ПИИ в развивающихся странах становятся более активными; взаимные инвестиции расширяются; структура сектора ПИИ претерпевает серьезные изменения – в частности, трансграничные слияния и поглощения стали важной формой инвестиций. На рис. 1 представлены представлены объем ПИИ в ряде стран мира за период 2017-2019 годов [4].



Рис. 1. Объем ПИИ в ряде стран мира

Общих тенденций в отношении ПИИ в развивающиеся и развитые страны мира не имеется. Объем ПИИ в США снизился. Объем ПИИ в Китай к 2019 году увеличился, тогда как инвестиционно привлекательный Гонконг в ПИИ существенное потерял, что связано в первую очередь с политической нестабильностью в самом Гонконге, которая отрицательно сказалась на инвестиционном климате.

В России ситуация с ПИИ неоднозначная. После событий 2014 года объемы ПИИ существенно сократились (рис. 2) [1]. Если в 2013 году ПИИ в Россию составили 69,2 млрд. долларов США, то в 2019 году - 31,9 млрд. долларов США. Необходимо отметить, что ПИИ из России за границу практически всегда по объему превышали ПИИ в Россию. В 2019 году ситуация изменилась, однако пандемия коронавируса наложила серьезный отпечаток на ПИИ.

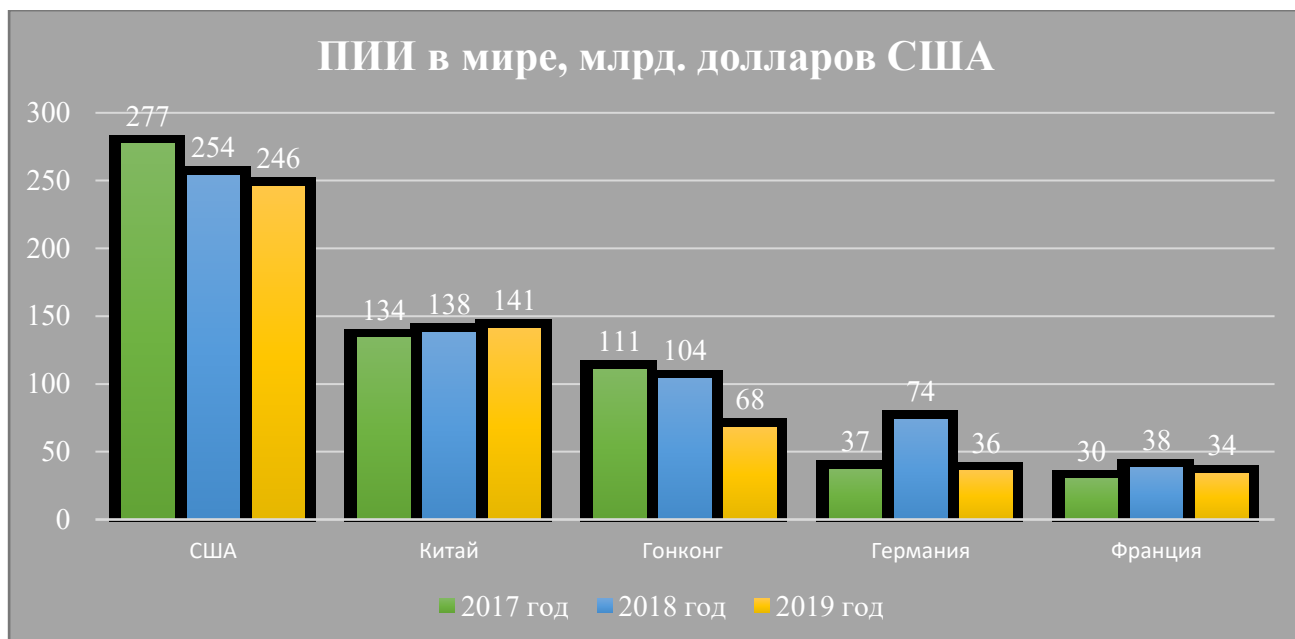

Рис. 2. ПИИ в России

В 2019 году по отношению к 2018 году темп роста ПИИ в Россию составил 363,9%. Между тем, в условиях пандемии поток инвестиций существенно снизился, причем отток инвестиций пришелся на первый квартал 2020 года (-3,8 млрд. долларов США). Говорить о последствиях пандемии и дальнейшем развитии инвестиционных потоков пока рано, поскольку продолжение распространения коронавируса вынудило государство вернуться к политике социально-экономических ограничений. В таб. 1 представлен индекс ввоза ПИИ в Россию за период 2017-2019 годов.

Таблица 1

Индекс ввоза ПИИ в Россию

	Доля в ввозе ПИИ	Доля страны в мировом ВВП по ППС	Доля в мировом экспорте	Доля в численности занятых в мире	Индекс
2019 год	2,0%	3,07%	2,3%	2,1%	0,82
2018 год	0,5%	3,12%	2,0%	2,1%	0,22
2017 год	1,9%	3,14%	2,0%	2,2%	0,80

С 2017 по 2019 год индекс был меньше единицы. Это говорит о том, что в эти года доля России в мировых ПИИ не соответствовала её экономическим позициям.

Потоки ПИИ структурируются не только по странам, но также и по сферам инвестиционной активности. В Европе наибольшей инвестиционной привлекательностью обладают цифровые технологии (в общем и целом, не только IT). Количество проектов в области цифровых технологий в 2019 году составило 1219, их доля в общем числе проектов – 19 %. В сфере деловых услуг сосредоточено 12%, 774 проекта [5]. Данная

логика инвестирования связана в первую очередь с бурным развитием цифровых технологий. Подчеркнем, что речь здесь идет именно о проектах, реализуемых посредством привлечения ПИИ. Реализация цифровых проектов привела к созданию 41 025 новых рабочих мест (15% от общего числа новых рабочих мест, связанных в связи с реализацией проектов на средства ПИИ). Между тем, большее число новых рабочих мест было создано в сфере производства транспортных средств и комплектующих к ним – 64 440 новых рабочих мест, что составило 23% от всех новых рабочих мест, связанных с реализацией проектов на средства ПИИ.

При анализе потоков ПИИ необходимо учитывать, что они не подчиняются единой логике развития. Н. В. Шемякина, В. И. Похилько справедливо отмечают, что единых экономических закономерности ПИИ в мире не существует. Набор стимулов и критериев предоставления инвестиций различен и определяется индивидуально по каждой стране. Соответственно, универсальных рецептов повышения ПИИ не имеется [6, с. 158]. Рекомендации по увеличению объема ПИИ могут носить лишь частный, национальный характер. В первую очередь стратегия формирования инвестиционной привлекательности зависит от категории национальной экономики – для развитых и развивающихся стран особенности привлечения ПИИ различны. Помимо этого, следует учитывать, что снижение или рост ПИИ могут обуславливаться не связанными с государством обстоятельствами.

И. В. Гомон, Д. Д. Юрков пишут о снижении привлекательности России для ПИИ. Объясняется это не внутренним инвестиционным климатом, а сокращением глобальной доходности ПИИ в принимающих странах и замедлением роста глобальных производственно-сбытовых систем [3, с. 121]. В 2020 году появился фактор пандемии, который весьма негативно сказался на ПИИ. Вероятно, что в некоторых областях потоки ПИИ возрастут (фармацевтика и др.), однако общая картина будет негативной. В условиях пандемии прямо пострадали развитые страны. Более того – народные волнения в США являются дополнительным негативным фактором (в первую очередь для американской экономики). В вопросе об инвестициях политический фактор играет заметную роль – вложение денег в нестабильные системы чревато высокими рисками. В некоторых случаях такое инвестирование оправдано, если имеется потенциально высокая вероятность стремительного экономического роста. Однако, это относится скорее к некоторым развивающимся странам. Тем не менее, США вряд ли в ближайшие годы утратит лидерство по объему поступающих в страну ПИИ по причине практически двухкратной разницы с Китаем.

По мере того, как степень экономической глобализации продолжает углубляться, взаимосвязь между прямыми иностранными инвестициями и внешней торговлей будет продолжать развиваться. России следует

адаптироваться к этой новой ситуации и нивелировать нынешнее отсутствие конкурентных преимуществ в области прямых иностранных инвестиций и повышать масштабы внешней торговли. Предприятиям необходимо формулировать реалистичные и выполнимые стратегические цели для прямых иностранных инвестиций на основе укрепления своего собственного развития. В то же время следует ускорить совершенствование законодательства об иностранных инвестициях, использовать фискальные и финансовые средства для поддержки предприятий, предоставлять высококачественные услуги для прямых иностранных инвестиций и стремиться установить связь между прямыми иностранными инвестициями и внешней торговлей. Проблематику также составляет вывоз капитала за рубеж в соотношении с ПИИ в российскую экономику. Одной из причин недостаточной инвестиционной привлекательности России является низкий уровень защиты прав собственности и корпоративных прав участников хозяйственных обществ. Отрицательно сказывается и политическая напряженность, которая существенно повышает инвестиционные риски. Отдельного внимания заслуживает привлечение инвестиций в регионы – ПИИ способны оказать заметное влияние на региональные экономические системы.

Таким образом, в настоящее время определилась тенденция снижения объемов ПИИ и изменения структуры их распределения, что было форсировано коронавирусной пандемией. Тем не менее, предпосылок для утраты США лидерства пока не имеется. Что же касается России, то нам представляется необходимой ориентация на европейскую практику с развитыми цифровыми технологиями и высокими гарантиями прав собственности.

Использованные источники:

1. Банк России. Статистика внешнего сектора [Электронный ресурс] // Режим доступа: https://cbr.ru/statistics/macro_itm/svs/ (дата обращения 30.10.20).
2. Галактионов В. С. Роль прямых иностранных инвестиций в глобальной экономике // Хроноэкономика. 2018. № 1 (9). С. 39-45.
3. Гомон И. В., Юрков Д. Д. Анализ прямых иностранных инвестиций в экономике России // Международный журнал гуманитарных и естественных наук. 2019. Том 1. № 5. С. 119-121.
4. Доклад ЮНКТАД о мировых инвестициях 2020 [Электронный ресурс] // Режим доступа: https://unctad.org/system/files/official-document/wir2020_en.pdf (дата обращения 30.10.20).
5. Исследование инвестиционной привлекательности стран Европы [Электронный ресурс] // Режим доступа: <https://ru.investinrussia.com/data/file/european-attractiveness-survey-russia-2019-rus.pdf> (дата обращения 30.10.20).

6. Шемякина Н. В., Похилько В. И. Мировой опыт привлечения прямых иностранных инвестиций // Вестник Института экономических исследований. 2018. № 4 (12). С. 153-159.

*Муминова Н.М.
преподаватель кафедры узбекского языка,
педагогике и физической культуры
факультет защиты растений и агрохимии
Андижанский институт сельского хозяйства и агротехнологии
Узбекистан, г. Андижан*

СПОСОБЫ АКТИВИЗАЦИИ ДЕЯТЕЛЬНОСТИ НА УРОКАХ РУССКОГО ЯЗЫКА

Аннотация: Этот процесс сопровождается существенными изменениями в педагогической теории и практике учебно - воспитательного процесса. Новые цели образования требуют обновления его содержания, поиска таких форм обучения, которые дадут возможность их оптимальной реализации. Обилие предметных знаний при отсутствии интереса и осмысленности изучения у обучающихся может осваиваться ими только за счет эксплуатации их памяти и послушания.

Ключевые слова: знания, студенты, технологии, обучение, преподавание, русский язык.

*Muminova N.M.
teacher of the department of the uzbek language, pedagogy and physical
culture
faculty of plant protection and agro chemistry
Andijan Institute of Agriculture and Agro technologies
Uzbekistan, Andijan*

WAYS TO ACTIVATE ACTIVITIES IN RUSSIAN LANGUAGE LESSONS

Abstract: This process is accompanied by significant changes in the pedagogical theory and practice of the educational process. New goals of education require updating its content, searching for such forms of education that will make it possible for their optimal implementation. They can master the abundance of subject knowledge in the absence of interest and meaningfulness of the study among students only through the exploitation of their memory and obedience.

Key words: knowledge, students, technology, learning, teaching, Russian language.

Русский язык является одним из сложных предметов. Следовательно, однотипность и шаблонность уроков снижают интерес к обучению, делают учебный процесс скучным и бесперспективным.

Поэтому проблема активизации деятельности обучающихся на уроках русского языка была и остаётся одной из самых актуальных. В течение долгого времени она стоит в центре внимания целого ряда научных педагогических коллективов и практических работников школы. Учёные и учителя давно ведут поиск путей активизации деятельности обучающихся. Тема эта большая и интересная, школе нужны такие методы, приемы и средства обучения, которые позволяли бы учить обучающихся мыслить. Система знаний по русскому языку нужна ученику не только сама по себе, а больше для решения разнообразных коммуникативных и практических задач.

Поэтому ученые стали искать ответ на вопрос о формировании общих приёмов познавательной деятельности, общих подходов к решению любой задачи в любой новой ситуации.

Активизация деятельности через самостоятельные задания поискового и творческого характера

При такой системе работы у обучающихся развивается интерес к родному языку, к работе с дополнительными источниками информации, умение ставить цель, наблюдать, сравнивать, обобщать, делать выводы, формируется поисковый и творческий тип деятельности, что выражается в качестве и количестве вопросов, которые обучающие задают учителю и друг другу на уроке, высказываниях собственной точки зрения, собственной позиции, в формировании самостоятельных выводов и оценочных суждений.

Данный метод активизации деятельности обучающихся можно представить в виде системы домашних заданий.

Этот подход к организации домашней работы обучающихся предполагает обучение подростков приемам самостоятельной учебной деятельности, а также способов, преследующих цель развития познавательной деятельности.

Творческий замысел заключается в том, чтобы повысить познавательную деятельность за счет расширения информации и применения заданий адекватных заявленной цели.

На первом этапе предполагается самостоятельное изучение теории, где использую следующие приемы работы: внимательно прочитать текст; определить, сколько в нем частей; придумать вопросы к каждой части текста и ответить на них с помощью учебника; дополнить вопросы, если в тексте остается невостребованная информация; выделить ключевые слова текста; найти значения незнакомых слов в словаре, опираясь только на ключевые слова; пересказать текст, проверяя себя по учебнику; по ключевым словам построить таблицу или разработать алгоритм.

При такой организации домашнего задания у обучающихся возникает интерес к словарям и справочной литературе, вырабатывается умение самостоятельно пользоваться ими. Также возникает интерес к слову, его истории, стремление писать грамотно и говорить правильно, выразительно, красиво.

На втором этапе обучающихся обучают нестандартным способам решения проблемы, поиску недостающей информации и использованию ее для решения возникающих проблем, развивают фантазию и воображение, вызывают интерес не только к результату, но и к процессу учебной деятельности. Здесь используют следующие задания:

а) разработка наглядных пособий, таблиц, схем;

Особенность этих пособий в том, что они помогают формированию самоорганизации обучающихся при выполнении домашнего задания, а также являются подсказками при самостоятельной работе. А главное - развитие зрительной памяти.

б) разработка новых вариантов кроссвордов, ребусов;

в) подготовка карточек для само диктантов;

г) тесты;

д) исправление допущенных ошибок;

На данном этапе используют групповую форму работы. Принцип формирования групп такой: объединение в группы учащихся примерно одинакового уровня обученности. Слабым - задания базового уровня, а сильным - повышенной трудности и творческие. Это позволяет осуществлять дифференцированный подход. Особое внимание уделяют взаимопроверке работ, что является эффективным средством формирования умений само- и взаимоконтроля. Оценка за выполненную работу заносится в тетрадь учета знаний, умений и навыков.

На третьем этапе создают условия для раскрытия собственного творческого потенциала обучающихся. Мыслительную деятельность обучающихся стимулируют различными средствами и приемами: используют методы исследовательского, эвристического характера, творческие задания, подразумевающие длительную самостоятельную работу (рефераты, творческие сочинения, эссе) [2, 260].

Наряду с традиционными формами организации учебной деятельности эффективно использовать на уроке занимательные элементы. Они традиционно применяются в обучении как средство возбуждения интереса к учению.

К ним можно отнести ребусы, кроссворды, карточки с анаграммами, графические диктанты, трехуровневые карточки, которые помимо определенной образовательной функции непосредственно стимулируют интерес обучающихся к изучаемому предмету. Основу таких учебно-познавательных подходов составляют термины русского языка [3, 187].

Такие серии заданий позволяют активно включаться учащимся в учебный процесс предмета «Русский язык».

Все рассмотренные элементы занимательности доказывают то, что они дают возможность закреплять все основные разделы русского языка, основные единицы уровней, важнейшие термины, помогают заложить теоретическую базу, формируют коммуникативные качества, популяризируют предмет. Они заставляют учащихся рассуждать логически, развивают речь, воображение, творчество, зрительное внимание, умение мыслить нестандартно, укрепляют память, помогают увидеть и объяснить многое в языке [1, 56].

Использованные источники:

1. Носирова М.К. Структура урока и ее составляющие. Международный научный журнал. Экономика и общество. № 6 (73) -с.: 2020.
2. Тиллабоева Ф.А. Подходы и принципы обучения русского языка. Международный научный журнал. Экономика и общество. № 6 (73) -с.: 2020.
3. Ульянова Е.В. Активизация интереса и познавательной деятельности на уроках русского языка через самостоятельные задания поискового и творческого характера // Русский язык в школе. - №5. - 2001. С. 187.
4. Организация самостоятельной работы студентов: материалы научно-методической конференции. – Красноярск, 2004.

АНАЛИЗ МЕХАНИЗМА ЗАКЛЮЧАЮЩИХ ПЛАТИН ВЯЗАЛЬНО-ПРОШИВНЫХ МАШИН

Аннотация: В статье рассматриваются вопросы определения технологических и конструктивных ограничений на движение заключающих платин вязально-прошивных машин

Ключевые слова: вязально-прошивная машина, рабочие органы, закон движения, технологические ограничения, конструктивные ограничения

*Muradov A.A.
dotsent*

*Namangan engineering-technological institute
Republik of Uzbekistan, Namangan*

ANALYSIS OF THE MECHANISM OF CLOSING PLATES OF KNITTING AND STITCHING MACHINES

Abstract: In this article, considered the question of clarifying the parameters of the movement of the working organs of knitting and piercing machines, taking into account technological and constructive conditions.

Keywords: Knitting and piercing machines, technological conditions, machine, loop-generator system, needle, law of motion, flexible element.

Целесообразность создания новой конструкции определяется тем, насколько вновь создаваемая машина отвечает требованиям развития экономики. Это условие определяет и требования к текстильному машиностроению, перед которым стоит задача – всемерно снижать себестоимость выпускаемой продукции. Решение этой задачи возможно только в том случае, если новая обеспечивать повышение производительности оборудования путем интенсификации скоростных режимов, повышение принципиально новых методов переработки сырья при изготовлении продукции. Из перечисленных задач вытекает одно из направлений в машиностроении для текстильной промышленности - модернизация оборудования, то есть улучшение технико - экономических показателей [1,2]. Основным и принципиально важным направлением в модернизации машин является конструктивная преемственность, которая характеризуется степенью использования деталей, сборочных единиц и

отдельных механизмов, применяющихся в базовой, исходной конструкции машин.

Технологические ограничения на взаимную установку и движение исполнительных органов определим, рассмотрев условия выполнения операций технологического процесса. Направленный на получение петельной структуры, этот процесс представляет собой последовательность десяти известных технологических операций: заключения, прокладывания, вынесения, прессования, нанесения, соединения, кулирования, сбрасывания, формирования, оттяжки. Взаимные положения исполнительных органов, определяющие условия выполнения технологических операций называются контрольными положениями исполнительных органов. Анализ контрольных положений позволяет сформулировать технологические ограничения на взаимную установку и движение исполнительных органов [3]. Механизм привода заключающих платин служат для облегчения работы пазовой движковой иглы при прокалывании волокнистого холста. Верхние платины подводятся в зону вязания в момент прокола движковой иглой волокнистого холста снизу вверх, прижимая его к неподвижным платинам [4]. При движении движковой иглы в обратном направлении платины выводятся из зоны вязания, не мешая протаскиванию нити через волокнистый холст.

Угол, характеризующий начальное положение кривошипа механизма привода заключающих платин – $\alpha_0 = 20^\circ$. Необходимые данные для анализа механизма: длина звеньев, координаты оси вращения и кинематическая схема показаны на рис.1.



Рис-1. Кинематическая схема привода заключающих платин

Наша задача определить перемещение звеньев, описываемые точками звеньев, в зависимости от угла поворота главного вала машины α_i .

Как известно, анализ механизма можно провести графическим или аналитическим методом.

Аналитическое решение задачи о положениях звеньев механизма будем находить по методу преобразования координат. Для определения положений всех звеньев механизма достаточно задать значение обобщенной координаты и постоянные параметры механизма. Механизм привода заключающих платин – плоский рычажной механизм первого класса, образованный последовательным соединением трех шарнирных передаточных четырехзвенников. Поэтому кинематический анализ выполняется в последовательности присоединения этих групп. систему

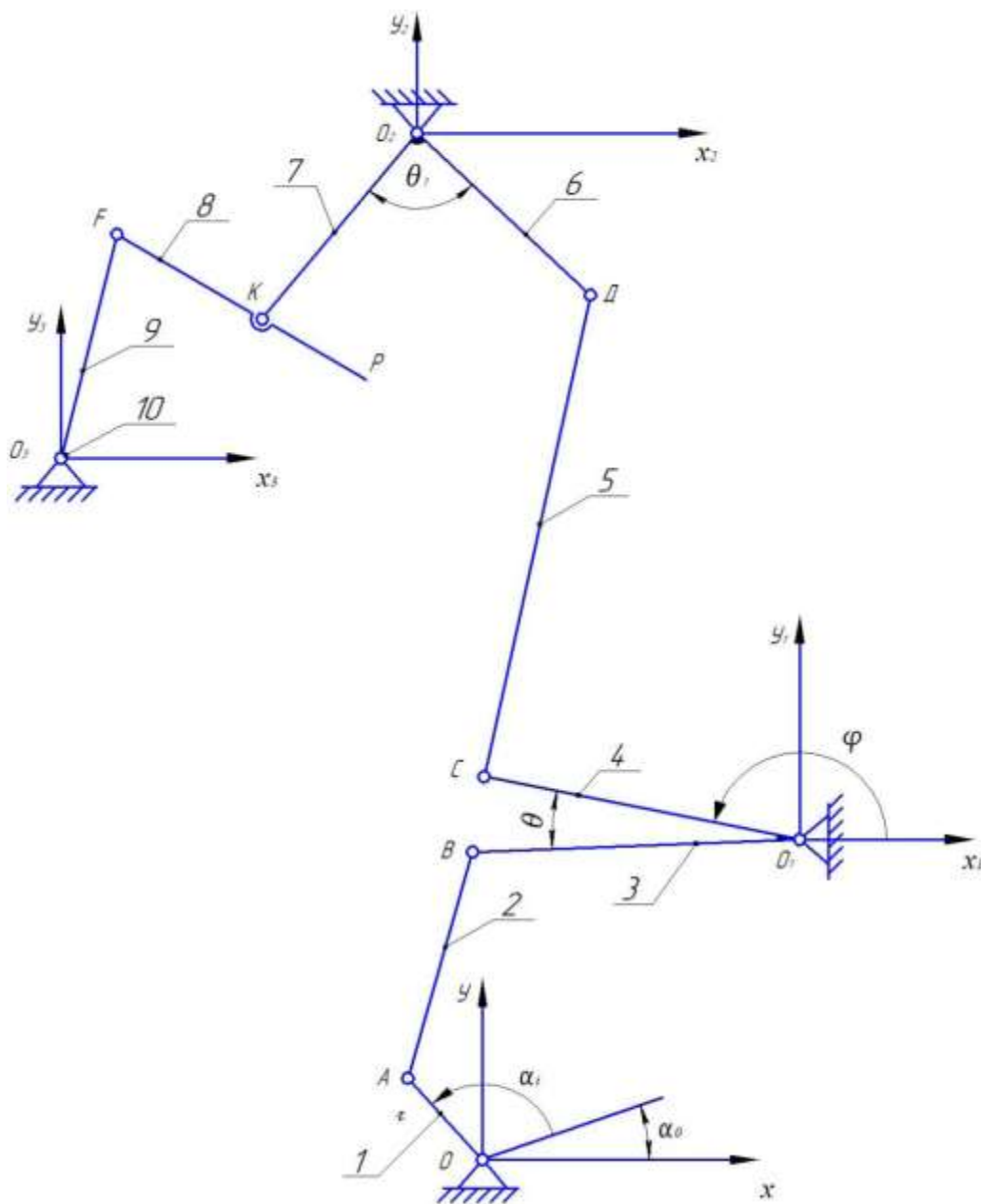
координат ХОУ. Координаты точки А в неподвижной системе координат находятся из соотношений:

$$\begin{aligned} X_A &= l_{OA} \cos(\alpha_i + \alpha_o) \\ Y_A &= l_{OA} \sin(\alpha_i + \alpha_o) \end{aligned} \quad (1)$$

Где α_i – углы поворота главного вала машины.

Координаты точки O_1 заданы схемой механизма. Следовательно, для первого шарнирного четырехзвенника $OABO_1$ оказываются известными координаты точек А и O_1 , то есть центров элементов внешних пар, что дает возможность найти положение точки В в системе ОХУ. Положение звена плоского механизма в движении относительно стойки определяется либо координатами двух его точек, либо координатами одной точки, расстоянием ее до другой точки и углом наклона линии, соединяющей эти точки. Для определения неизвестных координат точки воспользуемся известной теоремой из курса аналитической геометрии для определения расстояния между двумя данными точками. Имеем систему двух уравнений

$$(X_B - X_{o1})^2 + (Y_B - Y_{o1})^2 = L_{OB}^2 \quad (2)$$

$$(X_B - X_A)^2 + (Y_B - Y_A)^2 = L_{AB}^2$$

Где X_B, Y_B – искомые координаты точки В.

Система уравнений выражает условия пересечения геометрических мест точек В в незамкнутых кинематических цепях АВ и BO_1 , то есть пересечения окружностей с центрами в точках А и O_1 и радиусом L_{AB} и L_{OB} .

Решая систему уравнений (2) получаем

$$X_B = M - Y_B N \quad (3) \quad Y_B = T \pm \sqrt{T^2 - D} \quad (4)$$

$$M = \frac{l_{AB}^2 - l_{O_1B}^2 - X_A^2 - Y_A^2 + X_{O_1}^2 + Y_{O_1}^2}{2(X_{O_1} - X_A)}, \quad N = \frac{Y_{O_1} - Y_A}{X_{O_1} - X_A},$$

Где

$$T = \frac{M * N - Y_{O_1} + X_{O_1} * N}{1 + N^2}, \quad D = \frac{(X_{O_1} + M)^2 + Y_{O_1}^2 - l_{O_1B}^2}{1 + N^2}.$$

Для определения координат точек остальных двух шарнирных передаточных четырехзвенного O_1CD и O_2KFO_3 расчет проводится аналогично.

Зная координаты X_p и Y_p в зависимости от угла поворота главного вала α можно определить необходимое перемещение заключающих платин, которое удовлетворяет технологическим условиям, путем подбора радиуса кривошипа L_{OA} , при движении движковых игл.

Использованные источники:

1. Проектирование исполнительных механизмов вязально-прошивных машин "Экономика и социум" №12 (67), 2019г.

2. Muradov A.A. Pirnazarov A.U. Flexible joined needle mechanism for knitting stitch-bonding machines. Актуальные научные исследования в современном мире".5 (25), 104-106, Украина. 2017, май
3. Мурадов А.А. "Исследование и разработка механизмов петлеобразования с упругими звеньями для вязально-прошивных машин". Дисс. канд. тех. наук., -М., 1990.
4. Мурадов А.А. Проектирование петлеобразующей системы вязально-прошивных машин. Вестник ТашИИЖТ 2016г.№4

*Мякотина А.С.
студент специалитета 3 курса
факультет подготовки специалистов
для судебной системы (Юридический факультет)
Российский государственный университет правосудия
Россия, г. Иркутск*

*Заяшникова И.А.
студент специалитета 3 курса
факультет подготовки специалистов
для судебной системы (Юридический факультет)
Российский государственный университет правосудия
Россия, г. Иркутск*

АКТУАЛЬНЫЕ ВОПРОСЫ УПРАВЛЕНИЯ ИМУЩЕСТВОМ МУНИЦИПАЛЬНОГО ОБРАЗОВАНИЯ

Аннотация: Муниципальная собственность наряду с местными финансами составляет экономическую основу местного самоуправления. Поэтому вопросы формирования эффективного управления и распоряжения муниципальным имуществом являются приоритетными для муниципальных образований. Органы местного самоуправления от имени муниципального образования самостоятельно владеют, пользуются и распоряжаются муниципальным имуществом в соответствии с Конституцией РФ, федеральными законами и принимаемыми в соответствии с ними нормативными правовыми актами органов местного самоуправления.

Ключевые слова: муниципальное право, органы местного самоуправления, муниципальное образование, муниципальная собственность.

*Myakotina A.S.
a student of the specialty 3rd year
faculty of training specialists for the judicial system (faculty of law)
of the russian state university of justice
Russia, Irkutsk*

*Zayasnikova I.A.
student specialist 3rd year
faculty of Training Specialists for the Judicial System (Faculty of Law)
of the Russian State University of Justice
Russia, Irkutsk*

CURRENT ISSUES IN PROPERTY MANAGEMENT OF MUNICIPAL EDUCATION

Abstract: Municipal property forms the economic basis of local government. Therefore, the issues of formation of effective management and disposal of municipal property are priority for municipalities. Bodies of local self-government on behalf of the municipality independently own, use and dispose of municipal property. This is so thanks to the Constitution of the Russian Federation, federal laws and norms of local self-government bodies.

Keywords: Municipal property, municipal law, local government department, municipality.

Главным требованием к использованию муниципального имущества является максимально сбалансированное сочетание принципов экономической эффективности и социальной ответственности органов местного самоуправления за обеспечение жизнедеятельности муниципальных образований, социально-экономических интересов населения. Поэтому организация управления имуществом, находящимся в муниципальной собственности в современных условиях, - довольно сложная проблема, включающая в себя как традиционные административные, организационно-распорядительные, бюджетные, так и современные - маркетинговые, финансовые, экономические, налоговые методы управления.

Наиболее оптимальным должно быть использование сочетания организационно-правовых, организационно-экономических, финансовых и учетно-аналитических методов, учитывающее их содержание и целенаправленность воздействия управляющих субъектов на объекты управления посредством специальных инструментов прямого и косвенного воздействия.

Под организационно-правовыми методами понимается нормативно-распорядительное воздействие на участников имущественных отношений, выражающееся в форме нормативно-правовых актов органов местного самоуправления. В зависимости от их компетенции в сфере управления и распоряжения муниципальной собственностью это могут быть постановления, распоряжения, приказы, устанавливающие порядок распоряжения, правила и процедуры, регулирующие процессы управления муниципальным имуществом, приватизацию и приобретение объектов собственности, участие в гражданско-правовых сделках. К таким методам управления можно отнести создание, реорганизацию и ликвидацию муниципальных унитарных предприятий и учреждений, внесение вкладов и участие в капитале хозяйственных обществ, передачу имущества в хозяйственное ведение, оперативное и доверительное управление, аренду, лизинг, наем, безвозмездное пользование, приватизацию, ипотеку, залог,

хранение, страхование и другие формы распоряжения муниципальным имуществом.

Использование организационно-экономических методов позволяет регулировать имущественные отношения, процесс управления муниципальным имуществом посредством стимулирования экономических интересов субъектов имущественных отношений, применяя инструменты кредитно-денежной, бюджетной, налоговой политики. К таким методам могут быть отнесены прежде всего такие базовые функции управления, как планирование и организация, учет и контроль, инвентаризация имущества, а также современные функции управления: маркетинг, аудит, рыночная оценка и оценка эффективности использования имущества, инновационное управление и контроллинг, информационное обеспечение управления муниципальным имуществом.

Финансовые методы позволяют обеспечить деятельность по управлению и воспроизводству городского имущества с учетом получения и распределения доходов от его использования. Это позволяет оптимизировать нагрузку на расходную часть городского бюджета, максимизировать поступления в него от использования муниципальной собственности, устанавливать процент отчислений от прибыли муниципальных унитарных предприятий, прогнозировать получение дивидендов от участия в капитале хозяйственных обществ, других доходов в бюджет.

В ходе становления и развития местного самоуправления происходит изменение функций муниципальной собственности. Для оптимизации муниципального имущества и возможности вовлечения объектов недвижимости муниципальной казны в сделки (приватизация, сдача в аренду, передача в хозяйственное ведение, оперативное управление) необходимо наличие следующих документов на объект недвижимого имущества: межевого плана земельного участка, технического, кадастрового паспортов. Кроме того, должна быть осуществлена государственная регистрация права муниципальной собственности. В современной практике муниципального управления в России выделяются четыре основных способа ведения муниципального хозяйства: прямое управление, подрядная система, арендная система, муниципальная.

1. В случае прямого управления муниципалитеты осуществляют непосредственное руководство муниципальными предприятиями и учреждениями. Органы местного самоуправления вправе создавать муниципальные учреждения в форме унитарных предприятий и закреплять за ними имущество, находящееся в муниципальной собственности. Имущество может принадлежать унитарному предприятию на праве хозяйственного ведения и на праве оперативного управления.

Муниципальное унитарное предприятие, которому имущество принадлежит на праве хозяйственного ведения, владеет, пользуется и

распоряжается этим имуществом в соответствии со ст. 295 Гражданского кодекса РФ. Так, предприятие не вправе продавать принадлежащее ему на праве хозяйственного ведения недвижимое имущество, сдавать его в аренду, отдавать в залог, вносить в качестве вклада в уставный (складочный) капитал хозяйственных обществ и товариществ или иным способом распоряжаться этим имуществом без согласия собственника. Остальным имуществом, принадлежащим предприятию, оно распоряжается самостоятельно.

Один из основных недостатков права хозяйственного ведения состоит в значительных возможностях злоупотребления такими организациями предоставленной им собственником экономической свободой, используемой отнюдь не в интересах собственника и даже не в интересах такой организации, а с целью передачи имущества собственника в частный сектор на убыточных для собственника условиях. Муниципальные предприятия, за которыми имущество закреплено на праве оперативного управления, владеют, пользуются этим имуществом в пределах, установленных законом (ст. 296 ГК РФ), в соответствии с целями своей деятельности, назначением этого имущества и распоряжаются этим имуществом с согласия собственника этого имущества. Реальный объем правомочий конкретного учреждения в данном случае определяется собственником имущества с учетом гораздо большего числа ограничивающих факторов.

Право оперативного управления предоставляет возможности ограниченного владения и пользования муниципальным имуществом. Учреждение не вправе отчуждать или иным способом распоряжаться закрепленным за ним имуществом и имуществом, приобретенным за счет средств, выделенных ему по смете. Более того, у собственника по отношению к имуществу, закрепленному за учреждением, сохраняются более широкие вещные правомочия, позволяющие ему изымать в любое время это имущество без ликвидации либо реорганизации учреждения. И право хозяйственного ведения, и право оперативного управления как два "стандарта" вещных прав муниципальных юридических лиц не в состоянии охватить всего многообразия интересов, возникающих при опосредованной реализации права муниципальной собственности. Существуют такие виды муниципального имущества, предоставление которого унитарным предприятиям только по форме носит характер закрепления на праве хозяйственного ведения. По существу же оно мало чем отличается от права оперативного управления.

Например, закрепление на балансе жилищно-эксплуатационных организаций объектов муниципального жилищного фонда дает последним не больше прав на это имущество, чем муниципальному учреждению на объекты ведомственного муниципального жилищного фонда. Здания и сооружения, отнесенные к памятникам истории и культуры, особо

охраняются законом и предоставляются муниципальным унитарным предприятиям на праве хозяйственного ведения с дополнительными ограничениями правомочий владения, пользования и распоряжения. Преимуществами создания таких предприятий являются: получение дохода в долгосрочной перспективе в виде отчислений от чистой прибыли и платы за пользование муниципальным имуществом, а также возможность решения задач социально-экономического развития территории.

2. При подрядной системе выполнение определенных функций ведется не службами муниципалитета, а временно нанимаемыми на конкурсной основе частными подрядчиками, получающими часть прибыли. Подрядная система играет очень важную роль в современных условиях, однако ее эффективное применение требует соблюдения определенных принципов и правил, строгой системы учета и контроля. В Российской Федерации данный метод регулируется Федеральным законом от 21.07.2005 N 94-ФЗ "О размещении заказов на поставки товаров, выполнение работ, оказание услуг для государственных и муниципальных нужд".

3. Следующая форма распоряжения муниципальной собственностью - это передача муниципального имущества в аренду. Аренда применяется не с целью избавления органов местного самоуправления от расходов по эксплуатации имущества, а лишь при условии невозможности распорядиться муниципальным имуществом более выгодным образом. При этом муниципалитет на срок аренды, как правило, полностью отказывается от доходов, получаемых от использования сдаваемого имущества в обмен на фиксированные платежи.

Преимуществами передачи в аренду являются появление стабильного источника доходов и возможность использования объектов недвижимости в будущем для развития муниципального образования. Недостатки аренды: потеря возможных доходов в виде земельного налога; при фиксированной ставке возможны потери от инфляции.

Обладая большим, чем у любого другого собственника на данной территории объемом ликвидного имущества, муниципалитет способен диктовать свои условия рынку: сдерживать рост и разброс цен, задавать уровень корректности и стабильности договоров, снижать уровень произвола в отношении арендаторов со стороны частных владельцев недвижимости.

Естественно, для арендаторов умеренные цены, стабильность и предсказуемость условий аренды, открытые конкурсы на право аренды, выявляющие истинную стоимость объектов аренды, имеют особое значение. Именно благодаря этим факторам предприниматели охотнее арендуют муниципальную недвижимость, чем частную.

4. Муниципальная концессия представляет собой уступку муниципалитетом на определенный срок и на договорных условиях

частному хозяйствующему субъекту права устраивать и вести хозяйство в определенной сфере деятельности.

Фактически, использование подобной системы означает неспособность муниципалитета вести ту или иную часть местного хозяйства. Специалисты отмечают, что при концессиях около 50% прибыли, полученной в результате деятельности организации, переходит в частные руки. Местные власти оказываются связанными договором на много лет вперед и не могут отказаться от невыгодных концессионных договоров. Реальных же инструментов, позволяющих бороться с крупными внешними, особенно зарубежными, концессионерами у местных органов власти, как правило, нет.

В этом случае, как показывает практика, при концессии частная монополия не стремится вкладывать средства в развитие и техническое совершенствование производства, и при окончании договора муниципальному образованию возвращается изношенное оборудование и недвижимость. Сторонниками такой системы являются, прежде всего, представители частного бизнеса. Есть мнение, что концессия муниципального имущества, строительства муниципальных объектов, эксплуатации зданий экономически не эффективна и малоприспособна в практике муниципального управления.

Современная практика определяет преимущества и недостатки применения концессионного механизма. К его преимуществам относят:

- ограничение финансового участия муниципальных образований в осуществлении различных проектов;
- приток дополнительных денежных средств на территорию;
- создание дополнительного числа рабочих мест за счет строительства или реконструкции объектов коммунального назначения;
- расширение числа возможных инвесторов, так как в управление могут передаваться как предприятия в целом, так и отдельные объекты коммунальной инфраструктуры;
- пополнение собственности муниципального образования современным оборудованием, так как по истечении срока договора оно переходит в распоряжение органов местного самоуправления.

Но реализация концессионного механизма связана и с такими проблемами, как:

- отсутствие практики договорных отношений как между собственником и концессионером и потребителем коммунальных услуг, поэтому об эффективности этого способа можно судить по расчетным параметрам;
- необходимость закрепления ответственности за тарифное регулирование услуг, например, водоснабжения, за органами местного самоуправления (только при этом условии концессия будет работать);
- потеря влияния в сфере коммунального обслуживания;

- отсутствие стимулов для инвесторов и местных властей к заключению подобного типа договоров.

Таким образом, каждое муниципальное образование должно индивидуально подходить к данному методу управления муниципальной собственностью исходя из соображений продуктивности и с учетом возможных рисков.

Также имущество можно продать и сравнительно быстро получить относительно крупную сумму денежных средств единовременно и получать в дальнейшем доход в виде земельного налога. От эффективности управления и распоряжения муниципальным имуществом и земельными ресурсами в значительной степени зависят объемы поступлений в бюджет города. Но недостатками продажи являются потеря возможных доходов от использования недвижимости в будущем, а также трудности в поиске покупателей, которые обладали бы достаточно крупными средствами для полного выкупа.

Какую бы форму управления органы местного самоуправления ни выбрали, они должны стремиться максимально сохранить управляемость имуществом на своей территории, однако искусственно сохранять неэффективное муниципальное имущество не следует. Например, необходимость в муниципальных унитарных предприятиях можно обосновать исключительно в случаях, когда их цели и задачи не могут эффективно реализовываться предприятиями других форм собственности. При выборе способа управления собственностью следует учитывать и отраслевую специфику. Например, при реорганизации муниципальных предприятий в сфере жилищно-коммунального хозяйства следует руководствоваться тем, что не всегда можно использовать рыночные механизмы. Также необходимо, чтобы все мероприятия, связанные с управлением муниципальным имуществом, были увязаны как по срокам, так и по ресурсам (финансовым, материальным, трудовым), а также при решении проблем должны учитываться интересы развития местного сообщества и территории.

Таким образом, при выполнении этих условий эффективное управление муниципальной собственностью будет не только способствовать повышению доходности муниципального имущества, но и изменению роли имущества в социально-экономическом развитии муниципального образования. Это станет реальностью, если при выборе способа распоряжения муниципальным имуществом будут учитываться не только интересы различных сторон (населения, органов местного самоуправления, организации разных форм собственности), но и будут изыскиваться средства для текущего функционирования и стратегического развития территории.

Использованные источники:

1. Адамоков, Б.Б. Уставы муниципальных образований. Проблемы правового регулирования в субъектах Российской Федерации. Монография / Б.Б. Адамоков. - М.: Проспект, 2018.
2. Мильшин, Ю. Н. Муниципальное право России / Ю.Н. Мильшин, С.Е. Чаннов. - М.: Дашков и Ко, 2019.
3. Савостьянова, С. А. Правовое регулирование финансовой деятельности муниципальных образований Российской Федерации / С.А. Савостьянова. - М.: Юрлитинформ, 2018.
4. Федеральный закон от 06.10.2003 N 131-ФЗ (ред. от 09.11.2020) "Об общих принципах организации местного самоуправления в Российской Федерации"

*Набиев М.Я.
старший преподаватель
Содиқов Т.Б.
ассистент*

*Наманганский инженерно-технологический институт
Узбекистан, Наманган*

СОЛНЕЧНАЯ СУШКА ХЛОПКА

Аннотация: Исследуются сушильные барабаны, которые в настоящее время используются на хлопчатобумажных заводах для сушки хлопко-сырца, помимо потребления большого количества электроэнергии, могут использоваться для сушки хлопко-сырца, а также 1 тонны хлопко. потребляя много топлива для сушки хлопко, размер габаритных размеров не является экономически целесообразным.

Ключевые слова: сушка хлопко, сушильные барабаны, солнечный коллектор, КПД коллектора, солнечная энергия, тепловая энергия

*Nabiev M.Ya.
senior lecturer
Sodikov T.B.
assistant*

*Namangan Engineering Technological Institute
Uzbekistan, Namangan*

SOLAR DRYING COTTON

Annotation: Drying drums, which are currently used in cotton factories for drying raw cotton, are investigated, in addition to consuming a large amount of electricity, they can be used to dry raw cotton, as well as 1 ton of cotton. consuming a lot of fuel to dry cotton, the overall size is not economically viable.

Key words: cotton drying, tumble dryers, solar collector, collector efficiency, solar energy, thermal energy

Сушильное оборудование работает следующим образом: хлопок-сырец проходит через шахту 1 и подается на 2 лопаты, которые делят хлопок на две равные части. Благодаря своему прямому и обратному движению лопатка делит хлопок на две равные части, левую или правую, и передает ее в рабочие камеры. Рабочая камера движется вниз по направляющей 3. В это время горячий воздух выпускается в атмосферу через трубы 4 и 9, направляющие 8 и 10, которые проходят через хлопковые промежутки в сушильной камере, состоящей из поверхностей сетки горячего воздуха, и

выхлопных труб 5 и 11. В результате хлопок, попадающий в слои, равномерно сушится и через 12 валиков передается в следующий технологический процесс. Эти передаточные 12 роликов могут использоваться в качестве барабанного барабана, а также могут использоваться для очистки 26 ватных шариков от мелких загрязнений. отработанный воздух выводится в атмосферу через выхлопные трубы 5 и 11. В результате хлопок, попадающий в слои, равномерно сушится и через 12 валиков передается в следующий технологический процесс. Эти передаточные 12 роликов могут использоваться в качестве барабанного барабана, а также могут использоваться для очистки 26 ватных шариков от мелких загрязнений. отработанный воздух выводится в атмосферу через выхлопные трубы 5 и 11. В результате хлопок, попадающий в слои, равномерно сушится и через 12 валиков передается в следующий технологический процесс. Эти конвейерные ролики с 12 роликами могут использоваться в качестве барабанного барабана, а также могут использоваться для очистки 26 ватных шариков от мелких загрязнений. Как видно из приведенных выше строк, хлопкоочистительные заводы ассоциации «Узпахтасаноат» несут большую ответственность за развитие конкурентоспособного хлопкового волокна и текстиля на мировом рынке при сохранении естественного качества основной продукции. Мы несем большую ответственность перед специалистами в области снабжения отрасли. Это, в свою очередь, является обязанностью ведущих ученых, специалистов и исследователей отрасли, включая полное переоснащение хлопкоочистительных заводов научно обоснованным, современным новым и улучшенным низкоэнергетическим оборудованием и технологиями 27.

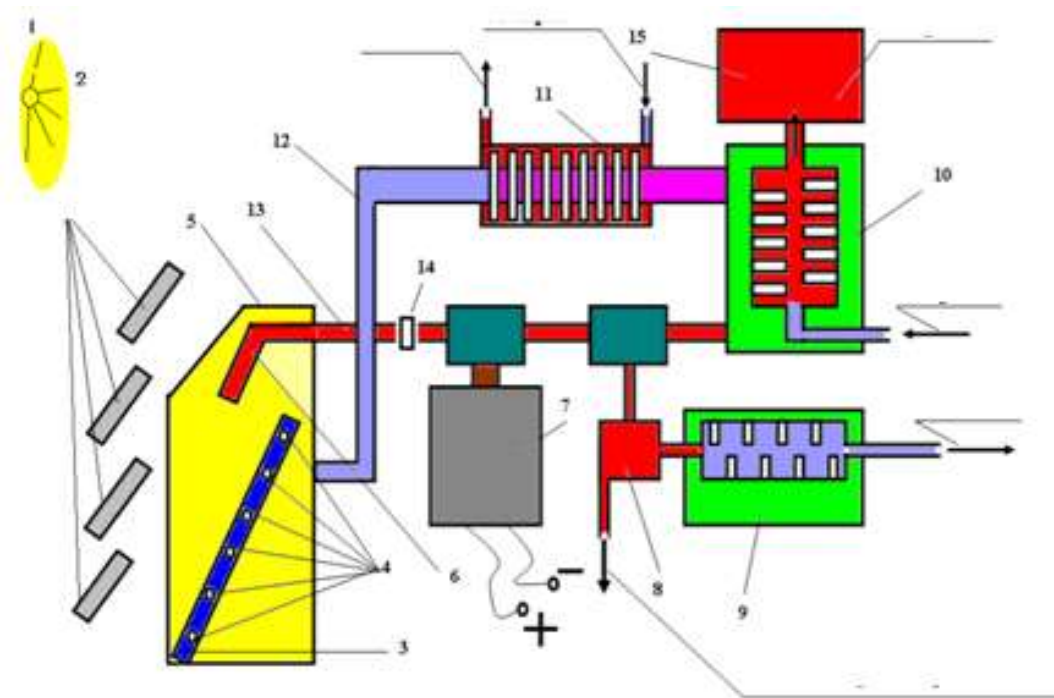

1 солнце, 2 коллектора, 3-4 метра, 5-емкость, 6-нагревательная эталонная трубка, 8-лопастной, 9-охладитель, 10-нагреватель, 11-водонагреватель, 12-трубка, 13-пар`трубное, 14-клапанное, 15-позиционное сушильное оборудование.

Рисунок 1. Многофункциональная солнечная установка, обеспечивающая электроэнергией сушку семян хлопчатника в поле

В настоящее время используются 2СБ-10, СБО, Тот факт, что сушка высококачественного хлопка в сушильных барабанах SBT приводит к высокому энергопотреблению, является одной из основных причин хлопкопрядения. Таким образом, основными факторами, влияющими на высокую эффективность сушки и очистки высококачественного хлопка-сырца в специальном новом оборудовании в этом устройстве, являются: температура сушильного агента, предотвращение гниения хлопка во время сушки, высокая эффективность оборудования. Основные параметры нового оборудования для сушки высококачественного хлопка-сырца выбираются путем анализа и изучения таких факторов, как урожайность и своевременное отделение пассивных загрязняющих веществ в хлопке, которые образуются при строительстве хлопка.



Рисунок 2. Сушилка для хлопка на солнечных батареях.

Использованные источники:

1. Михеев М.А., Михеева М.М. Основы теплопередачи. - М.: Энергия, 1977.
2. Теплотехнический справочник /Под. общ. ред. В.Н. Юренева и П.Д. Лебедева. - М.: Энергия, 1976.
3. Ю. Вукалович М.П. Новиков И.И. Техническая термодинамика. - М.: Энергия, 1968.
4. М. Тулкинов, Ш. Сайпиддинов, Метод улучшения коэффициента мощности в однофазной сети // Экономика и социум №12(67) 2019 https://iupr.ru/osnovnoy_razdel__12_67_2019/
5. С. Султонов, М. Камалидинов, Мобильная электростанция «солнце-ветер» в перспективе // Экономика и социум №12(67) 2019 https://iupr.ru/osnovnoy_razdel__12_67_2019/
6. Б. Махмудов, Х. Абдуллаев, Конвейер устройство для сушки фруктов. // Экономика и социум №12(67) 2019 https://iupr.ru/osnovnoy_razdel__12_67_2019/
7. Ражабов И.Т, Шоюсупов Ш, Фотогальванические характеристики и коэффициент неидеальности фотоВАХ // Экономика и социум №12(67) 2019 с

УДК: 639.33

*Насритдинов К.М., кандидат исторических наук
доцент кафедры «Гуманитарные науки»
Андижанский институт сельского хозяйства и агротехнологии
Республика Узбекистан
Уролов С.Г.
ассистент кафедры «Гуманитарные науки»
Андижанский институт сельского хозяйства и агротехнологии
Республика Узбекистан*

СЕЛЬСКОЕ ХОЗЯЙСТВО УЗБЕКИСТАНА ВО ВРЕМЯ ВТОРОЙ МИРОВОЙ ВОЙНЫ

Аннотация: В статье авторы на основе архивных документов, научно-исторических источников и литератур анализируют историю и развитие сельского хозяйства Узбекистана в годы второй мировой войны XX века.

А также в статье авторы раскрывают суть и причины, объективных и субъективных трудности в сельском хозяйстве, показывают историческую картину героического трудового подвига сельских трудящихся, делают соответствующие научные выводы.

Ключевые слова: вторая мировая война, фашизм, земледелие, орошение, народные экстенсивный путь развития, пленум, гектар, севооборот, хлопок кенаф, сахарная свекла трудовые ресурсы, эвакуация, трудодень, мельница, кетмень, лопата, лом, земляные работы, ирригационная система, ирригация.

*Nasritdinov K.M., candidate of Historical Sciences
Associate Professor of the Department of Humanities
of the Andijan Institute of Agriculture and Agrotechnology
the Republic of Uzbekistan
Urolov S.G.
Assistant of the Department of Humanities
of the Andijan Institute of Agriculture and Agrotechnology
the Republic of Uzbekistan*

AGRICULTURE OF UZBEKISTAN DURING THE SECOND WORLD WAR

Resume: In the article, the authors analyze the history and development of agriculture in Uzbekistan during the Second World War of the twentieth century on the basis of archival documents, scientific and historical sources and literatures.

And also in the article, the authors reveal the essence and reasons, objective and subjective difficulties in agriculture, show the historical picture of the heroic labour feat of rural workers, draw the appropriate scientific conclusions.

Keywords: World War II, fascism, agriculture, irrigation, folk extensive development path, plenum, hectare, crop rotation, cotton kenaf, sugar beet labour resources, evacuation, workday, mill, ketmen, shovel, scrap, earthworks, irrigation system, irrigation.

Вторая мировая война, как и другие миролюбивые народы мира, стала серьезным испытанием для сельскохозяйственных рабочих Республики Узбекистан. В конце концов, начавшаяся война поставила перед ними огромную и сложную задачу, такую как бесперебойное снабжение промышленности сырьем, продуктами питания и одеждой. Сложность ситуации заключалась в том, что, во-первых, в довоенный период сельское хозяйство республики было в основном ориентировано на выращивание хлопка, который был стратегически важным сырьем для центральной промышленности, а продукты питания для населения обеспечивала Союзный фонд. Когда разразилась война, подача продуктов питания из центра прекратилась, и в результате перед правительством республики стояла важная задача - найти внутренние возможности прокормить население. Во-вторых, рост населения городов республики за счет эвакуированного населения из прифронтовых районов привел к дальнейшему увеличению потребности населения в продуктах питания. В-третьих, в связи с мобилизацией полноправных крестьян, которые составляли основной трудовой ресурс в сельском хозяйстве, для работы на фронте и в военной промышленности тяжелый сельскохозяйственный труд во время войны возлагался на стариков, женщин и подростков. В-четвертых, прекратились поставки новых тракторов, сельхозтехники и запчастей из центра в МТС и совхозы, и даже тракторы, машины и некоторые лошади из существующих хозяйств были отобраны для нужд Красной Армии, что еще больше ухудшило сельскохозяйственную ситуацию.

В связи с войной на всех уровнях сельского хозяйства был установлен строгий график работы. В частности, с 26 июня 1941 года минимальное количество обязательных рабочих дней было увеличено в 1,5 раза, причем для подростков с 12 лет. Обязательно проработать определенное количество рабочих дней. Сельскохозяйственных рабочих заставляли работать 12-14 часов [1.В-81].

В годы войны структура сельского хозяйства республики кардинально изменилась. Были приняты меры для увеличения производства зерна, сахарной свеклы, конопли, коконов, овощей и бахчевых культур при сохранении хлопководства в качестве основной отрасли. Прежде всего, высокими темпами велись работы по расширению посевных площадей и

увеличению поливной мощности. Выступая на V пленуме ЦК Компартии Узбекистана (б) в декабре 1941 года, Усмон Юсупов в своем выступлении поставил задачу решить проблему зерна в Узбекистане, обеспечить себя мукой и хлебом. В частности, по решению Пленума в 1942 г. посевные площади в стране увеличились на 521,8 тыс. Га, урожай зерна увеличился с 5,5 млн. Центнеров в 1941 г. до 15 млн. Центнеров, сахарная свекла засеяна не менее чем на 70 тыс. Га, хлопчатник с гектара. Чтобы повысить урожайность в среднем до 19,8 центнеров [2.V.-2, 44,151], только весной 1942 г. планировалось освоить 130 000 га новых орошаемых земель и включить их в сельское хозяйство в результате строительства ирригации через народный хашар [3.В. -169].

В первые годы войны расширились орошаемые земли, на которых выращивали зерно. Использовались зарангские земли, заповедники, тугайные, лалмикорские земли. В 1942 г. зерновые и зернобобовые культуры были посажены на 1 408,1 тыс. Га, в 1943 г. - на 2 090,2 тыс. Га. В результате производство зерна увеличилось с 4,8 миллиона центнеров в 1941 году до 5,3 миллиона центнеров в 1943 году, что позволило удовлетворить потребности населения. В сельском хозяйстве запущена новая отрасль для Узбекистана - сахарная свекла. Самаркандская, Ташкентская, Ферганская и Кашкадарьинская области страны специализируются на выращивании сахарной свеклы. В 1942 году сахарная свекла была засеяна в стране на 65 000 га, а в последующие годы - на более чем 70 000 га плодородных земель. Для переработки сахарной свеклы и производства сахара построены Зирабулакский, Кокандский и Янгиюльский сахарные заводы. В 1944 г. 1 млн. 373 тысячи центнеров, в 1945 году 1 миллион. Поставлено 646 тысяч центнеров сахарной свеклы. Во время войны Узбекистан поставлял четверть сахара, производимого во всем Союзе.

В годы войны рабочие также самоотверженно трудились на полях животноводства, шерсти, каракуля, кожи, шелководства. Благодаря стараниям, проявленным в приготовлении мяса, масла, молока, картофеля, овощей и дынь, фруктов, создана прочная пищевая база. За годы войны сельхозработники республики доставили государству 1262 тысячи тонн зерна, 54,1 тысячи тонн коконов, 482 тысячи тонн картофеля и овощей, 57,5 тысячи тонн фруктов и винограда, 36 тысяч тонн сухофруктов, 159 тысяч тонн мяса, 22,3 тысячи тонн. тонны шерсти.

Даже в годы войны хлопководство оставалось важной отраслью сельского хозяйства. Несмотря на упорный труд хлопкоробов, план производства хлопка на 1942–1943 годы не был выполнен. План передачи хлопка государству выполнен на 57,7%, а средний урожай хлопка в колхозах упал с 17,4 центнера до 7,1 центнера в 1942-1943 годах [4.В-449]. Это было связано с рядом объективных обстоятельств. Во-первых, посевные площади под хлопком уменьшились с 927 650 га в 1941-1943 годах до 625 343 га. Во-

вторых, отсутствие средств механизации. В-третьих, минеральные удобрения, нехватка топлива. В-четвертых, агротехника выращивания хлопка ухудшилась из-за нехватки рабочей силы для своевременной вспашки, кошения, полива и очистки ирригационных сетей. Республиканское руководство это прекрасно понимало. Уменьшение посевных площадей под хлопчатником привело к увеличению посевных площадей под зерновыми, сахарной свеклой и другими продовольственными культурами. Однако руководство Центра не принимает во внимание эти объективные факторы. Поэтому руководителей республики вызвали на обсуждение в Москву, обвинив в пренебрежении хлопковой отраслью. От них требовалось каким-либо образом реализовать план производства хлопка, чтобы еще больше увеличить его [5.В-106]. Это было не более чем дальнейшее усиление административно-командных методов управления. Итоги этой борьбы нашли отражение в постановлении ЦК ВКП (б) от 6 марта 1944 года «О работе ЦК Коммунистической партии Узбекистана (б)». X Пленум ЦК Коммунистической партии Узбекистана в апреле 1944 года разработал меры по реализации этого решения. В 1944 году союзное правительство выделило узбекским хлопкоробам 2 300 новых тракторов, 300 грузовиков, 375 000 тонн минеральных удобрений и другую сельскохозяйственную технику. В результате в республике был выполнен госплан по производству хлопка в 1944 году, государству поставлено на 375 тыс. Тонн хлопка больше, чем в 1943 году, а в 1945 году план по производству хлопка выполнен. За годы войны хлопкоробы республики выплатили государству 4 миллиона. Они поставили 806 тысяч тонн хлопка-сырца.

В годы войны усилились сплоченность и взаимопомощь рабочих и крестьян. Промышленные предприятия переняли колхозы и снабдили их сельскохозяйственной техникой и запчастями. Горожане активно участвовали в сборе урожая сельхозпродукции. Колхозники активно участвовали в строительстве промышленности страны. К примеру, только в строительстве Фарходской ГЭС участвовало около 70 тысяч колхозников. Рабочие и крестьяне Узбекистана объединились, самоотверженно трудились и внесли весомый вклад в победу над фашистами. Во время войны около 160 000 человек были награждены Медалью Славы за самоотверженный труд в тылу.

Война оставила узбеков в крайней нужде. В результате мобилизации всего на фронт, для победы возникла нехватка продовольствия. В городах введена раздача продуктов питания и промышленных товаров по карточкам. Планируется, что в сутки рабочим и служащим будет выдаваться 400-500 граммов хлеба, а членам семьи - 300 граммов. На практике население получало хлеба меньше установленной нормы. Мясо, масло, рыба, макаронные изделия, крупы также распределялись в установленном порядке, часто не в количествах, указанных в карточке. Жить сельчанам

стало труднее. Нормы раздачи продуктов питания и промышленных товаров сельскому населению не вводили. Им почти не платили за те дни, когда они работали. Продовольствие им выдавалось в фиксированных количествах, в зависимости от того, какая сельскохозяйственная продукция доставлялась государству в цехах пресс-кооперативов. На колхозных полях в зависимости от суточной загруженности колхозник на мукомольной фабрике отвешивал 500 грамм муки за одну норму труда с подписью бригадного стола. Поэтому колхозники старались с избытком выполнять суточную норму работы на полях [7.В-46].

В целях улучшения продовольственного обеспечения населения было разрешено создание подсобных хозяйств при промышленных предприятиях. Им выделено 53 тысячи гектаров земли во временное пользование. Рабочие и служащие обычно занимаются индивидуальным садоводством.

В годы войны каждая колхозная семья должна была сдавать в год более 40 кусков мяса, 4 килограмма масла и 40 яиц. Кроме того, каждый работающий член колхоза должен был выплачивать в среднем от 500 до 1000 сумов в год по государственной ссуде [1.В-81].

Перед лицом нехватки продовольствия деньги все больше обесценивались, и бушевали спекуляции. Несмотря на нужды, рабочие промышленности и сельского хозяйства самоотверженно трудились на победу, ради своих детей и мужей, ушедших на фронт. Несмотря на трудности, о семьях солдат, ушедших на фронт, всячески заботились, их детей поместили в ясли и детские сады. Колхозы и совхозы обеспечивали семьи воинов продуктами питания и урожаем.

В заключение следует отметить, что в тяжелые годы войны народ Узбекистана, в очередной раз продемонстрировав свои высокие человеческие качества, своим упорным трудом внес свой вклад в великую победу над общим врагом человечества - фашизмом.

Использованные источники:

1. Жалилов С., Комил А. Избоскан ва избосканликлар (Она диёримизнинг ўтмиши ва бугунги ҳаётидан лавҳалар).-Т.: “VEKTOR-PRESS”,2007.-Б-224.
2. Ўз.МА. 58-фонд, 17-рўйхат, 26-иш, 2,44,151-варақлар.
3. Насритдинов К.М. Фарғона водийсининг суғорилиш тарихи (На узбекском языке) Т.: “Янги аср авлоди”, 2009. Б-224.
4. Ўзбекистон совет мустамлакачилиги даврида.-Т.: “Шарқ”,2000. Б-449.
5. Муҳитдинов Н.А.Кремлда ўтказган йилларим. I-жилд, -Т.: 1994.Б.-109.
6. Насруллаев М.У. Ўзбекистоннинг уруш гирдобига тортилиши. <http://e-tarix.uz/vatan-tarixi/477-vatan-tarixi.html>.
7. Халилов К., Насритдинов Қ.М. Қорасув тарихидан лавҳалар.-Т.: “Янги аср авлоди”, 2010. Б-88.

*Недригайлова А.П.
ГОАУ Курской области
«Курская академия государственной
и муниципальной службы»
Россия, г. Курск*

СОЦИАЛЬНАЯ СФЕРА

Аннотация: В данной статье рассматриваются определение, цели и составные части, а также затрагивается нормативно-правовая база социальной сферы.

Ключевые слова: социальная сфера, население.

*Nedrigailova A.P.
GOAU of the Kursk region
"Kursk Academy of State
and Municipal Service"
Russia, Kursk*

SOCIAL SPHERE

Abstract: This article discusses the definition, goals and components, as well as the legal framework of the social sphere.

Key words: social sphere, population.

Социальная сфера, безусловно, является основным элементом каждого государства, которое имеет социально-ориентированную экономику, особенно, государств, решающих актуальные и общественно важные вопросы и проблемы и чья деятельность направлена на оказание социальных услуг населению.

Авторы Кураков Л. П., Кураков В. Л., Кураков А. Л. большого энциклопедического экономико-юридического словаря дают следующее определение социальной сферы: «совокупность отраслей, предприятий и организаций, непосредственно связанных и формирующих уровень жизни населения, его благосостояние»

Данная сфера обеспечивает решение социальных проблем населения, проживающего в границах муниципального образования, а также находит свое проявление в социальной инфраструктуре и комплексе соответствующих отраслей, а также в том социальном пространстве, в котором реально осуществляется жизнедеятельность населения, его общение, взаимодействие и непосредственно все социальные связи.

В структуре социальной сферы выделяют ряд элементов: здравоохранение, образование, культура, а также искусство как отдельный аспект социальной сферы жизни человека, спортивные организации, социальное обеспечение, коммунальное обслуживание, общественное питание и пассажирский транспорт.

Если рассмотреть более подробно, то к составным частям элементов социальной сферы можно отнести следующие учреждения и организации: занимающиеся медицинским обслуживанием, лаборатории, медицинские центры, образовательные организации разного уровня, дворцы и дома культуры, музеи, безусловно, стоит отметить, что разного рода парки, а также жилищно-коммунальное хозяйство, городской транспорт и организации, оказывающие материальную помощь нуждающимся, тоже является значимой частью социальной сферы.

Каждый её элемент имеет свои основные цели, например: сохранение и повышение уровня здоровья населения государства, организация и обеспечение доступного и, по возможности, бесплатного медицинского обслуживания населения, удовлетворение потребности людей в знаниях, умениях и навыках, а также обогащение духовной жизни людей и создание условий для социальной и культурной деятельности населения.

Данные цели актуальны и реализуются на любом уровне: федеральном, региональном, так и на муниципальном уровне. В последнее время социальной сфере, непосредственно ее развитию, уделяют всё больше внимания, причем как на государственном, так и на муниципальном уровне.

Социальная сфера оказывает непосредственное влияние на качество жизни и уровень благосостояния населения. Большая часть социальной сферы состоит из работников, получающих заработную плату из бюджетных средств. Поэтому одной из главных задач органов власти является формирование и реализация муниципальной социальной политики.

Нормативно-правовую базу, регулирующую социальную сферу в Российской Федерации составляет целый ряд актов: международные документы, например, Всеобщая декларация прав человека и гражданина, Конституция РФ, Трудовой кодекс РФ, Семейный кодекс РФ, Жилищный кодекс РФ., Федеральный закон «Об образовании в Российской Федерации» от 29.12.2012 N 273-ФЗ (ред. от 31.07.2020), Федеральный закон «Об основах охраны здоровья граждан в Российской Федерации» от 21.11.2011 N 323-ФЗ (ред. от 31.07.2020), Федеральный закон «О социальной защите инвалидов в Российской Федерации» от 24.11.1995 N 181-ФЗ (ред. от 24.04.2020), указы и послания президента, например Указ Президента Российской Федерации от 7 мая 2012 г. № 597 «О мероприятиях по реализации государственной социальной политики» или Послание Президента РФ Федеральному Собранию от 15.01.2020 «Послание

Президента Федеральному Собранию», а также множество государственных программ и национальных проектов.

В последнее время, составные части социальной сферы приобретают всё большее значение в развитии общественного производства. Они оказывают непосредственное влияние на качество жизни и уровень благосостояния населения.

Основная часть работников социальной сферы получает заработную плату из бюджетных средств, это подтверждает, что человек также является частью социальной сферы.

Таким образом, структуру социальной сферы муниципального образования образуют как учреждения образования, медицины, культуры, физической культуры и спорта, бытового и транспортного обслуживания, занятости и другие, обеспечивающие жизнедеятельность человека на данной территории, так и непосредственно сам человек, его физические и духовные характеристики.

Использованные источники:

1. Законодательство Российской Федерации Сборник основных федеральных законов РФ - <https://fzrf.su/zakon/>
2. Волков Ю.Е. Социальные отношения и социальная сфера 2003 г. - <https://dlib.eastview.com/browse/doc/4995799>
3. Кураков Л. П., Кураков В. Л., Кураков А. Л. Экономика и право: словарь-справочник. - М.: Вуз и школа.- 2004.
4. Малюгов А.А. Теоретико-методологические основы управления социальной сферой муниципальных образований - Экономика и социум № 11 (30) - 2016 - <https://www.iupr.ru>
5. Туишева М.Р. Особенности социальной сферы как институционально-экономической категории - Вестник экономики, права и социологии, 2012, № 1 Экономика - <http://www.vestnykeps.ru/0112/30.htm>

*Ниязметова Н.Б.
преподаватель кафедры педагогики
начального образования
ТГПУ им. Низами*

СОВЕРШЕНСТВОВАНИЕ МЕТОДИКИ ОБУЧЕНИЯ СТУДЕНТОВ ТЕХНОЛОГИИ НА ОСНОВЕ ИНТЕГРИРОВАННОГО ОБУЧЕНИЯ

Аннотация. Современный период развития мировой педагогики диктует необходимость положить конец воспитанию молодежи, приобретению ею узкопрофессиональных знаний по профессии, обладать широким спектром интегрированных знаний в системе непрерывного образования, в том числе и в системе общего образования.

Ключевые слова. Интеграция, технология, начальное образование, методология, эффективность.

*Niyazmatova N. B.
lecturer of the Department of pedagogy
primary education
TSPU them. Nizami*

IMPROVING THE METHODOLOGY OF TEACHING TECHNOLOGY STUDENTS BASED ON INTEGRATED LEARNING

Annotation. The modern period of development of world pedagogy dictates the need to put an end to the education of young people, their acquisition of narrow professional knowledge in the profession, to have a wide range of integrated knowledge in the system of continuing education, including in the system of general education.

Keywords. Integration, technology, primary education, methodology, efficiency.

В настоящее время важно использовать образование и опыт стран мира в подготовке квалифицированных кадров для народного хозяйства нашей страны в общеобразовательных школах. Разработка научно-методических основ внедрения достижений интерактивного образования в практику является одной из актуальных проблем.

Проблемы интеграции преподавания и обучения в начальной школе очень важны с точки зрения современного времени в теории и практике и будут более актуальны в свете новых социальных требований. Сегодня, в связи с колоссальными изменениями в науке, образовании и производстве, возникающие потребности ставят перед школьным образованием новые

задачи. Современная система дачи знаний направлена на установление основ науки на высоком уровне, развитие мышления, понимания и представления о мире в целом, правильное понимание происходящих вокруг событий, воспитание молодежи, способной понять их суть. Наука, которая преподается в школах, порождает у выпускника школы одно-мировоззренческое (фрагментарное) мировоззрение.¹⁴²

В современной науке высока тенденция к интеграции экономических, политических и культурных наук. То, что школа преподает предметы общего образования здраво, не преподает их связно, вызывает у учащихся затруднения, препятствующие их полному познанию и пониманию всего бытия в целом. По мнению наших ученых, интеграция входит в число дидактических принципов и среди них является ведущей. Такая концепция порождает необходимость еще раз рассмотреть вопрос об интеграции в системе образования, вопрос о взаимозависимости и взаимообусловленности.

Внедрение интеграции в систему образования может стать ключевым инструментом в решении образовательных и воспитательных задач, стоящих между школой и обществом. Интегрированные уроки учат детей понимать от природы, что они понимают единство мировоззрения, непрерывность событий. Следует также учитывать, что интеграционные связи классов в начальной школе слабо развиты научно. А поскольку различные идеи и взгляды, которые существуют, противоречивы и противоречивы, проблема интеграции все еще остается одним из спорных вопросов среди наших приобретений. Развитие теории применения интеграции в педагогическом процессе представляет собой соперничество научно-педагогических концепций, основных и важных. Интеграция неразрывно связана с дифференциацией. Эта гармония проявляется в восстановлении системы их стремления понять знания, которые они получают в учениках. Интеграция - это сближение и взаимосвязь наук в процессе дифференциации. Интеграционный процесс - это стадия соединения взаимосвязей между дисциплинами в новом, более высоком качестве, проявляющаяся в более высокой форме. Следует отметить, что в основе интеграционного процесса лежит народная педагогика и научная педагогика далекого прошлого. Интеграция связана с наукой. Н.Ю. Светловская понимает, что интеграция-это "создание нового целого (учебных предметов, видов деятельности) из нескольких частей выявленного однополого элемента, находящихся в разных единицах, а затем объединение этих частей элемента в отдельное целостное качество, ранее не существовавшее".

¹⁴² Мавлонова Р.А., Рахмонкулова Н. - Комплексная педагогика начального образования | Т.: Или-Зиё 2009. Стр.55

Причем, интеграция описывается как метод составления множественных учебных предметных материалов, на основе естественного подчинения задаче и единственной цели методики.

Аналогичную трактовку понятия "интеграция" дает Л. Н. Бакарева. Она раскрывает интеграцию как соединение и конвергенцию наук. "Интеграция-это наука и коммуникация, инструмент, который поднимает обучение на новый качественный уровень, то есть позволяет создать целый "монолит знаний".¹⁴³

Как бы ни совершенствовалась материальная база, стандарт, учебный план, учебные программы и учебники в образовании, достижение ожидаемого базового результата, обеспечение глубоких и основательных знаний, достижение самореализации в высоком качестве будет по-прежнему напрямую связано с творчеством, сомнительностью, квалификацией преподавателя, проводящего теоретическую и практическую подготовку.¹⁴⁴

Известно, что процесс обучения и обучения неразрывно связаны друг с другом, но в процессе формирования человеческой личности образование приобретает мастерство. Потому что образование включает в себя весь комплекс образовательного процесса. Она охватывает все аспекты интегрированного образования (умственное, нравственное, экономическое, трудовое, эстетическое, гигиеническое, физическое воспитание) в воспитании современного человека и обеспечивает их взаимообусловленность.

В процессе интегрированного обучения читатель приобретает всесторонние знания о целостности мироздания, мироздании, законах природы, взаимодействии природы, общества и человека. Природа сможет ощутить ее красоту, насладиться ею, приобрести навыки почестей.

В освещении содержания каждого предмета его сущность оформляется преподавателем с целью глубокого, научно обоснованного воображения учащихся, продуктивного использования времени, широкого охвата возможностей применения их теоретических знаний на практике, в быту и производстве, расширения их политехнических представлений, и выражается в календарно-тематическом плане.

Содержание наук начального образования через комплексное совершенствование преподавания:

- создать мониторинг уровня усвоения знаний и духовного становления учащихся;
- постоянный контроль за тем, в какой степени знания, данные учителями, осваиваются учащимися;
- обеспечение последовательности и преемственности в формировании духовности личности учащегося в процессе начального образования;

¹⁴³ Мавлонова Р.А., Тораева О.Т., Холикбердиев К.М. «Педагогика» Т., «Учитель» 1998 г.

¹⁴⁴ «Мавлонова Р.А. Санакулов. Ходиева Д.П. «Труд и его методы обучения». Учебник Т-2007. 3-6

- организация занятий, направленных на формирование интегрированных уроков с учетом психологических особенностей учащихся начального класса;

- индивидуализация процесса обучения.¹⁴⁵

Взаимозависимость плана наук в естественнонаучной категории.

Ниже приведена связь между техникой, физикой, математикой, химией, рисованием и другими науками. Учитель определяет, как студенты усваивают свои знания в этой области, проводя беседу, и на основе знаний, которые они получают из этих дисциплин, они будут понимать структуру и входной процесс обрабатываемых металлов.

Естественные науки в научной категории				
Технология	Физика	Математика	Химия	Черчение
Процесс резания и режущий инструмент, его геометрия: общее представление о процессе формирования стружки, глубине резания, скорости проталкивания и резания, долговечности инструмента. Виды режущего инструмента, пальцы, фрезы, фрезы, опилки и т. д.	Свойства твердых тел (сорок-это погружение нетвердого тела в твердое тело, клин. Прочность, масса и ускорение, работа трения и тепло)	Прямая и плоскость-параллельность в пространстве, свойства углов многоугольника	Растворы эмульсии, минеральные масла и животные жиры, хладагенты	Обрезки

Ниже мы приводим примеры неразрывно связанных с другими дисциплинами дисциплин при преподавании технологии в начальных классах:

Технология и рисунок.

Роль, которую технология играет в изображениях, в конечном счете велика, потому что, прежде чем сделать одну деталь или кусок, его изображение или эскиз рисуется и отображается читателям. Читатели также

¹⁴⁵ Турсинова Г. «Комплексный инновационный подход к совершенствованию уроков начальной школы» ИМТ. Ташкент-2014 60-р

могут скопировать и нарисовать эти картинки в своем блокноте. Учащиеся создают изображение одной и той же детали или фрагмента с помощью этих картинок. Оказывается, здесь у студентов навык рисования всевозможных картинок тоже идет на формирование. Но из опытов известно, что рисование-задача не из легких. Многие студенты сталкиваются с трудностями при выполнении этой работы, потому что им не хватает знаний и навыков в рисовании. Поэтому учитель на уроках труда должен будет дать учащимся представление о техническом чертеже предметов, эскизе, наглядном изображении, последовательности работы по рисованию картин, а также о разнице цветов, их пропорциональном расположении и т.¹⁴⁶

Технология и математика.

На уроках технологии учащимся понадобятся такие понятия, как прямой угол, перпендикулярные и параллельные линии, прямоугольные треугольники и прямоугольный прямоугольник, чтобы сформировать фигуры. Кроме того, учащиеся должны будут определить углы детали или объекта, центры дуг, другие размеры прямой и изогнутой линии с помощью различных инструментов, таких как ось симметрии, симметричное рисование фигур, круг, делающий попытки, пончик, пончик, линейка угла, круг, на уроки труда. В такие времена будут необходимы науки, связанные с геометрией. Следовательно, в школьном курсе геометрии имеются большие возможности для выполнения таких работ, как использование чертежных и измерительных инструментов, замена поверхностей. Задача состоит в том, чтобы разумно использовать их на уроках труда. Также знание арифметики необходимо при выполнении таких работ, как определение длины заданных предметов, подачи, высоты, поверхности, объема, а также различных размеров, расчет того, сколько материала будет затрачено времени.

Технологии и образование.

Как известно, основная часть уроков технологии состоит из практических занятий. По этой причине тот факт, что студенты не устают от практических занятий, во многом обусловлен их физическими нагрузками. Из этого следует рациональный вывод, что необходимо координировать работу и занятия физкультурой между собой. Следовательно, с физическим воспитанием молодежи решается взаимосвязанный вопрос подготовки ее к труду, то есть в ней формируются профессиональные физические характеристики, необходимые для трудовой деятельности личности, навыки движения, волевые и социальные качества. В частности, можно согласовать работу пиления, градуировки с такими упражнениями, как гимнастика, забивание молотком, бокс, назначение скашив-ных работ. Стоит отметить, что если в 4-м классе занятия физкультурой в общем плане связаны с уроками технологии, то в

¹⁴⁶ Азизходжаева Н.Н. педагогическая технология и педагогическое мастерство. Ташкентский ТДПУ. 2003 год. 29-стр

старших классах нетрудно адаптироваться непосредственно к таким профессиям, как плотник, токарь, электрик пайвандчи, штукатур, сантехник, слесарь-сантехник, например.¹⁴⁷

Технология и литература.

Известно, что на уроках техники значительно проявляется связь литературы с наукой. Потому что в литературных произведениях дуют идеи трудового воспитания и труда. На уроках трудового воспитания необходимо использовать их как фактор, читать нужные отрывки. Стоит также упомянуть, что знаменитые поэты использовали замечательные предметы, которые были сделаны в прошлом мастерами. Например, информируя студентов о пластине для чтения книг, они непосредственно сосредоточились на творчестве наших ученых, таких как Низами, Аль-Хорезми, Абдурахман Джами, Лутфи, Алишер Навои, Мукими, Фуркат. Стоит отметить, что они читают книгу именно с этого устройства, то есть с планшета.

Технология и родной язык.

Значение речи и языка в жизни невероятно важно. Как мы все знаем, в период существования бывшего Советского Союза внимание к узбекскому языку, терминам, словарю, богатству языка замедлилось. Принятие в 1989 году Закона Республики Узбекистан "О государственном языке" также оказало влияние на работу педагогов трудового воспитания. При описании тем необходимо указывать узбекскую форму некоторых терминов в соответствии с родным языком. Среди них есть слова и термины, которые нельзя перевести на узбекский язык, поскольку они являются выражениями и ранее не использовались, поэтому необходимо использовать эти слова без изменений. Примеры таких терминов: компас, тиски, отвертка, резьба, резина, крепление, пластик, агрегат, дрель, бор, вольтметр, амперметр, радио, лампа, диод, долото, штангенциркуль, конвейер, токарный станок.

Технология и история.

Наша древняя и молодая земля имеет долгую историю и культурное наследие. У нас сложились десятки уникальных профессий: народные промыслы, живопись, архитектура. Умелые мастера сделали прекрасные вещи, построили великолепные здания. Их работа была продолжена самоотверженными учениками, поэтому мы не можем процветать в нашей настоящей жизни, в нашей будущей жизни, не глядя в прошлое. Неслучайно первый президент Ислам Каримов сказал: «Нет будущего без исторической памяти». В воспитании гармонично развитого поколения история играет особую роль на уроках трудового воспитания в школе. Студенты могут познакомиться с историей строительства, мастерами строительства, умелыми руками, ювелирами, плотниками, кузнецами. В наши дни внимание к народному искусству и ремеслам растет с каждым днем.

¹⁴⁷ Азизходжаева Н. Н. педагогическая технология Ю. и педагогического мастерства (учебное пособие). - Т.: издательство Литературного фонда Союза писателей Узбекистана, 2006 62-стр

Например, сейчас во многих школах учащихся учат делать такие предметы, как столы, двери, рамы, ворота, стулья, сандалии, люльки, сундуки, национальные стулья.

Технологии и экология.

Сегодня, в условиях рыночной экономики, экономное использование инструментов и сырья стало одним из основных требований повестки дня. Неэффективное использование сырья и оборудования на практических занятиях, в конечном итоге, приводит к экологическим проблемам. Поэтому, давая студентам такие материалы, как дерево, металл, пластик, необходимо объяснить, почему необходимо использовать это сырье экономно. Им можно рассказать, как эти вещи существовали в течение долгого времени и каким образом, и насколько они влияют на природу или зависят от нее. Вышеупомянутые моменты показывают, что междисциплинарные связи в трудовом образовании являются важным фактором повышения эффективности образования. Мы знаем, что невозможно связать один урок со всеми предметами сразу, но можно выбрать концепции и информацию, которые имеют отношение к изучаемой теме, и использовать их при необходимости. Концепции из других дисциплин, включая иностранные языки и экономику, также могут широко использоваться на уроках технологий.

Из рассмотренных выше методов и направлений стало ясно, что обучение технологиям в начальных классах с использованием интегрированного образования является высокоэффективным. Принимая во внимание мировоззрение младших школьников, уровень проникновения в сферу образования, обучение их технологической науке в тесной связи с другими дисциплинами глубоко проникает в сознание учеников и облегчает их освоение. Если интегративное образование будет реализовано не только в сфере технологий, но и по всем предметам начальной школы, произойдет повышение уровня усвоения учащимися, их мировоззрения.

Использованные источники:

1. Закон Республики Узбекистан «Об образовании» (Гармонично развитое поколение - основа развития Узбекистана. 1997, Т., Издательство «Шарк»)
2. Национальная программа обучения. (Гармонично развитое поколение - основа развития Узбекистана. 1997, издательство «Шарк»)
3. Мавлонова Р.А., Тураева О.Т., Холикбердиев К.М. «Педагогика» Т., «Учитель» 1998 г.
4. Х.Санакулов, М.Хайдаров «Практикум по бумаге в начальной школе» 1996 г.
5. Мавлонова Р.А., Горохова, Оглуздина О. «Методика трудового воспитания» Т., «Учитель» 1986 г.
6. Азизходжаева Н.Н. Педагогическая технология и педагогическое мастерство. Ташкентское ТДПУ. 2003 г.

7. Азизходжаева Н.Н. Педагогическая технология и педагогическое мастерство (Учебник). - Т .: Издательство Литературного фонда Союза писателей Узбекистана, 2006.

8. Р.А.Вонлова, Н.Рахмонкулова «Интегрированная педагогика начального образования» Т .: Или-Зиё 2009.

Информация в Интернете

<http://www.pedagog.uz>.

<http://www.ziyonet.uz>.

*Ноибжонова Х.М.
ассистент
Андижанский медицинский институт
Узбекистан*

БИОХИМИЧЕСКИЕ СВОЙСТВА ЖЕЛЕЗЫ

Аннотация: в этой статье обсуждаются биохимические свойства железа.

Ключевые слова: железа, железняк, гемоглобин, гем, анемия.

*Noibjonova Kh.M.
assistant
Andijan state medical institute
Uzbekistan*

BIOCHEMICAL PROPERTIES OF IRON

Abstract: This article discusses the biochemical properties of iron.

Keywords: iron, iron ore, hemoglobin, heme, anemia.

Железо принадлежит к числу семи металлов древности (золото, серебро, ртуть, медь, железо, олово, свинец). Железо — самый распространенный после алюминия металл на земном шаре: оно составляет 4% (масс.) земной коры. Встречается железо в виде различных соединений: оксидов, сульфидов, силикатов. К важнейшим рудам железа относятся *магнитный железняк* Fe_3O_4 *красный железняк*- Fe_2O_3 , *бурый железняк* $2Fe_2O_3 \cdot 3H_2O$ и *шпатовый железняк* $FeCO_3$.

Железо - (лат. Ferrum), химический элемент, атомный номер 26, атомная масса 55,847. Природное железо представляет собой смесь четырех нуклидов с массовыми числами 54 (содержание в природной смеси 5,82% по массе), 56 (91,66), 57 (2,19) и 58 (0,33). Обычно образует соединения в степенях окисления +3 и +2. Известны также соединения с атомами железа в степенях окисления +4, +6. В периодической системе Менделеева железо входит в группу VIII. В четвертом периоде, к которому принадлежит и железо, в эту группу входят, кроме железа, также кобальт и никель. Эти три элемента образуют триаду и обладают сходными свойствами.

Физические свойства. Железо серебристо-белый металл. Тверже чем Al но по сравнению Au и Ag мягче. Чистое Fe имеет температуру плавления $1539^{\circ}C$ температура кипения $2861^{\circ}C$. В промышленности железо получают из железной руды, в основном из гематита и магнетита. А химически чистое железо получают электролизом растворов его солей.

Хотя в организме взрослого человека содержится всего около 4 г железа, оно играет важнейшую роль в процессах переноса кислорода к тканям и клеткам, удаления углекислого газа, окислительного фосфорилирования. Три четверти атомов железа в организме находятся в форме гемоглобина, состоящего из порфиринового комплекса железа, называемого *гемом*, и белка глобина. Гемоглобин обеспечивает транспорт кислорода к тканям организма а родственные ему белок миоглобин, обуславливает способность тканей запасать кислород. Гемоглобин содержится в эритроцитах крови, а миоглобин присутствует в мышечной ткани. Оба соединения имеют красный цвет обусловленный наличием в них атома железа в степени окисления +2. Окисление железа приводит к потере биологической активности гемоглобина и миоглобина. Суточная потребность человека в железе (6-20 мг) с избытком покрывается пищей (железом богаты мясо, печень, яйцо, хлеб, шпинат, свекла и другие). В организме среднего человека (массой тела 70 кг) содержится 4.2 г железа, в 1 л крови около 450 мг. При недостатке железа в организме развивается железистая анемия, которую лечат с помощью препаратов, содержащих железо (актиферрин, фенюльс, мальтофер, ферронал, гемофер и т.д). Препараты железа применяются и как общеукрепляющие средства. Избыточная доза железа (200 мг и выше) может оказывать токсичное действие.

Использованные источники:

1. Аскаров И.Р., Производные ферроцена. Фергана. 1999. ст. 24-70.
2. С.С.Косимова. Биогенные элементы.-Т.:1990 г.
3. М.М. Mirkomilova. Analytical chemistry.-Т.:1996 у.
4. N.T.Olimxojayeva Bioorganic and physic-colloidal chemistry.-Т.:2005.

*Ноибжонова Х.М.
ассистент
Андижанский медицинский институт
Узбекистан*

СВОЙСТВА ВИТАМИНОВ

Аннотация: в этой статье обсуждаются химические свойства и использование витаминов.

Ключевые слова: витамины, аллергия, синтетические витамины.

*Noibjonova Kh.M.
assistant
Andijan state medical institute
Uzbekistan*

PROPERTIES OF VITAMINS

Abstract: This article discusses the chemical properties and uses of vitamins.

Keywords: vitamins, allergy, synthetic vitamins.

Некоторые сведения о витаминах, к которым мы привыкли в повседневной жизни, на деле оказываются неверными. Поэтому перед началом приема нужно изучить как распространенные заблуждения, так и полезные факты о витаминах. Итак, приступим. **Много витаминов – всегда полезно.** Зачастую можно услышать мнение, что чем больше употреблять витаминов, тем лучше. На деле это оказывается не совсем так. Интересные факты про витамины подтверждают, что важно строго соблюдать необходимые дозировки. Ведь переизбыток этих веществ иногда бывает опасней недостатка. Не зря врачи делают акцент на том, что авитаминоз может вызвать ослабление организма и различные заболевания, но ни в коем случае не призывают поглощать бездумно тонны фармацевтической продукции. К примеру, всем известный, полезный и, казалось бы, безопасный витамин С, интересные факты о котором гласят, оказывается, что его переизбыток очень вреден. Он может быть причиной повышения давления и температуры, нарушения работы почек и бессонницы, и даже уменьшения выработки инсулина. Исходя из этого, ни в коем случае нельзя злоупотреблять даже самыми известными витаминами, не изучив досконально их необходимую дозировку.

Аллергия на витамины. Частая ошибка мам – постановка диагноза «аллергия на витамин» без анализов. Такие мамы забывают, что в

многокомпонентных витаминных комплексах используются различные ароматизаторы, красители и добавки – именно они зачастую и служат причиной аллергии.

При правильном питании синтетические витамины не нужны. Правильное сбалансированное питание с большим количеством овощей и фруктов – это, несомненно, очень хорошо. Однако современные фрукты и овощи далеко не так богаты витаминами, как нам хотелось бы. Из-за истощения почв и использования большого количества удобрений они не обеспечивают организм полезными веществами в полной мере. Поэтому грамотно подобранные витаминные комплексы должны присутствовать в каждой семье.

Важные факты

Рассмотрим самые необходимые витамины и интересные факты о них.

- В овощах, как известно, много полезных веществ. Однако не храните их долго ни в холодильнике, ни при комнатной температуре, потому как через несколько дней количество витаминов в них значительно уменьшится. Примерно на 30%.

- Очень полезен витамин А, интересные факты о нем следует знать многим мамам. Например, примечательно, что он разрушается под воздействием ультрафиолета. Кроме того, боится любой термической обработки.

- Занимательные факты о витамине С: если бы люди не утратили способность, которая была у них миллионы лет назад, они могли бы, как другие животные, сами синтезировать его. Но теперь нам приходится принимать этот полезный элемент с пищей.

- Группа В включает витамины, факты о которых также интересны. Меньше всего нам требуется витамина В12. В1 стоит употреблять тем, кто плохо переносит полеты и морские путешествия, его много в растительных продуктах. При преобладании в рационе белковой пищи, стоит особое внимание уделить витамину В6. А В2 уничтожается солнечными лучами.

Использованные источники:

1. Спиричев, Владимир Борисович. Что могут и чего не могут витамины: монография / Спиричев В. Б. - 3-е изд., доп. - Москва: Миклош, 2003. - 299 с. – ISBN 5-900518-11-6
2. Жбанова, Екатерина Викторовна. Витамины: от истории открытия до наших дней / Е. В. Жбанова; Рос. акад. с.-х. наук, Всерос. НИИ генетики и селекции плодовых растений им. И. В. Мичурина. - Мичуринск: МичГАУ, 2009. - 231 с. - Библиогр.: с. 226-231. - ISBN 978-5-94664-174-6
3. Кузнецов, Евгений Дмитриевич. Макробиотика живого питания/ Кузнецов Е. Д., Креславский В. Д., Клериков Н. В. - Ярославль: Найс, 2012. - 159 с. - (Библиотека основ эстетической макробиотики). - Библиогр.: с. 153-156.

*Норқобилов М.Н.
заведующий кафедры физического воспитания и спорта
Ташкентский институт ирригации и
инженеров механизации сельского хозяйства*

ФИЗИЧЕСКАЯ КУЛЬТУРА И ЗНАНИЯ СТУДЕНТОВ

Аннотация: В данной статье говорится об основах развития, включающего в себя принципы физического воспитания среди обучающихся студентов. В работе раскрыта суть содержания физической культуры и её аспектов. В основе работы лежит стратегия приоритетных направлений государственной политики в сфере физкультурного образования студентов, отражающая возрастание количества сверхсложных систем и технологий, информатизацию всех сфер жизни общества.

Ключевые слова: физическая культура, структура, физическое воспитание, студенческий спорт, аспекты, односторонности и фрагментарности.

*Norkobilov M.N.
Head of the Department of Physical Education and Sports
Tashkent Institute of Irrigation and Agricultural
Mechanization Engineers*

PHYSICAL EDUCATION AND STUDENTS' KNOWLEDGES

Annotation: In this article given information about the basics of development, which includes the principles of physical education among students. The work reveals the essence of the content of physical culture and its aspects. The work is based on the strategy of priority directions of state policy in the field of physical education of students, reflecting the increase in the number of highly complex systems and technologies, informatization of all spheres of society.

Key words: physical culture, structure, physical education, sports for students, aspects, one-sidedness and fragmentation.

Физическая культура студентов представляет собой неразрывную составную часть высшего гуманитарного образования. Она выступает качественной и результирующей мерой комплексного воздействия различных форм, средств и методов на личность будущего специалиста в процессе формирования его профессиональной компетенции. Материализованным результатом этого процесса является уровень

индивидуальной физической культуры каждого студента, его духовность, уровень развития профессионально значимых способностей.

Содержание физической культуры студентов, стратегия приоритетных направлений в её развитии подвержены активному влиянию социально-экономических факторов. Государственная политика в области высшего образования определяет социальный заказ на будущего специалиста и степень его физической готовности. Существенным недостатком содержания физической культуры студенческой молодежи 80-х годов является её несомненный консерватизм, унитарность и выраженная деперсонализация (неспособность человека к личностному самовыражению в отношениях с другими людьми). Поэтому, на современном этапе перехода вузов Республики Узбекистана на многоуровневую систему образования, остро встала проблема поиска новых нетрадиционных подходов, позволяющих повысить её эффективность.

Перед студенческой молодежью сегодня обществом поставлена глобальная социально-экономическая задача по интегрированию отечественного культурного потенциала в мировое сообщество. Однако её реализация по силам только специалистам новой формации, отвечающим по целому комплексу профессиональных и личностных качеств современным требованиям. Помимо глубоких профессиональных знаний по избранной специальности такой специалист должен обладать: высокими физическими кондициями и работоспособностью, личной физической культурой, духовностью, неформальными лидерскими качествами. Он должен не бояться конкуренции, уметь принимать самостоятельные решения, т.е. быть творчески мыслящей, активной и высоконравственной личностью. Намечившаяся сегодня стратегия развития физической культуры студентов, выражаемая в тенденции отхода от унитарной концепции, либерализации и последовательной гуманизации педагогического процесса является гарантом формирования специалиста новой формации.

Структура физической культуры студентов включает три относительно самостоятельных блока: физическое воспитание, студенческий спорт и активный досуг. Для деятельности студентов в сфере физического воспитания приоритетными являются образовательные аспекты.

Целью физического образования является удовлетворение объективной потребности студентов в освоении системы специальных знаний, приобретении профессионально значимых умений и навыков. Гуманистическая направленность педагогического процесса предполагает целенаправленную интеграцию биологических и социальных потребностей, интеллектуальных и нравственных аспектов при реализации генетически обусловленных природных задатков каждого студента на протяжении его обучения в вузе.

Таким образом, создаются объективные предпосылки к преодолению односторонности и фрагментарности подготовки специалистов в вузе, приданию педагогическому процессу комплексного, целостного характера. Объективным критерием эффективности этого концептуального подхода является существенное сокращение сроков социально-психологической адаптации студентов к обучению в вузе, повышение их социальной активности, качественное повышение учебно-познавательной продуктивности, повышение духовности личности каждого студента.

Студенческий спорт представляет собою обобщенную категорию деятельности студентов в форме соревнования и подготовки к нему с целью достижения предельных результатов в избранной спортивной специализации. Это требует от студента проявления максимальных психофизических кондиций, мобилизации его резервных возможностей.

Занятия спортом выступают формой самовыражения и самоутверждения студента, определяя его образ жизни, общекультурные и социально значимые приоритеты. На передний план в спорте выдвигается стремление к успеху, поощряется стремление личности к реализации своих возможностей в рамках определенного спортивного сценария. Результатом сопряженной учебной и спортивной деятельности студентов является формирование социально значимых качеств: социальной активности, самостоятельности, уверенности в своих силах, а также честолюбия.

В сфере активного досуга реализуются, главным образом, биологические потребности студентов в двигательной активности, здоровом образе жизни, получении удовольствия от занятий различными формами физической культуры. Высокая вариативность выбора студентами формы активного досуга подвержена сильному влиянию флуктуации культурных и социальных факторов, синергично взаимодействующих с биологическими запросами личности.

Трехкомпонентная структура физической культуры студентов определяет специфику выделения дифференцированных целей и педагогических задач каждого её структурного блока. Тем не менее, это не является существенным препятствием к определению генеральной цели физической культуры студентов: целенаправленного формирования гармонично развитой, высоко духовной и высоконравственной личности, квалифицированного специалиста, овладевшего устойчивыми знаниями и навыками в сфере физической культуры.

Занятия по физическому воспитанию строятся таким образом, чтобы обеспечить максимальный профессионально-прикладной эффект при воспитании предприимчивости, оригинальности мышления, настойчивости, честолюбия, интуиции, способности идти на риск.

Стратегия приоритетных направлений государственной политики в сфере физкультурного образования студентов, отражающая возрастание количество сверхсложных систем и технологий, информатизацию всех сфер

жизни общества, определяет новые требования к творческой подготовке будущего специалиста, его готовность к высокопроизводительному труду. Их реализация связана с раскрытием психофизических возможностей студенческой молодежи, гармоническим развитием ее физических, интеллектуальных и духовных сил путем использования физических упражнений, различных видов двигательной активности, рационального питания, природосообразного режима труда и отдыха. Используемая с этой целью физкультурная деятельность связана с физическим упражнением, сущность которого отражает целенаправленно выполняемые двигательные действия, включающими как моторно-исполнительные (операционные механизмы), так и познавательные, проектно-смысловые и эмоционально-оценочные аспекты.

Использованные источники:

1. Виленский М. Я. Физическая культура в научной организации учебного труда студентов. М., 1993.
2. Виленский М. Я., Ильинич В. И. Физическая культура работников умственного труда. М., 1987.
3. Гулько Я. Н. Социально-биологические основы физической культуры. М., 1994.
4. Евсеев Ю. И. Физическая культура (учебное пособие для студентов вузов). Ростов н/Д : Феникс, 2004 г.
5. Евсеев Ю. И. Основы гигиены и самоконтроля. Ростов н/Д, 1988.
6. Евсеев Ю. И., Асланов В. А., Кравченко П. В. Самостоятельная физическая подготовка студентов полевых специальностей. Ростов н/Д, 1988.

*Огнев П.Н.
студент 3 курса
ВСФ ФГБОУВО «Российский
государственный университет правосудия»
Россия, г. Иркутск
Доржиева А.Б.
ВСФ ФГБОУВО «Российский
государственный университет правосудия»
Россия, г. Иркутск
научный руководитель: Власова Е.Л., кандидат педагогических
наук
доцент*

МУНИЦИПАЛЬНО-ПРАВОВАЯ ОТВЕТСТВЕННОСТЬ

Аннотация: Настоящая статья посвящена исследованию муниципально-правовой ответственности как части института ответственности органов и должностных лиц местного самоуправления. Проводится анализ теоретических положений и законодательства Российской Федерации относительно проблем обособления и разграничения муниципально-правовой ответственности. Поддерживается мнение о представлении муниципально-правовой ответственности как самостоятельном виде.

Ключевые слова: юридическая ответственность, муниципально-правовая ответственность; субъекты муниципально-правовой ответственности.

*Ognev P.N.
3rd year student
VSF FSBEI «Russian State University
Justice»
Russia, Irkutsk
Dorzhiyeva A.B.
3rd year student
VSF FSBEI «Russian State University
Justice»
Russia, Irkutsk
Scientific adviser: Vlasova E.L., candidate of Pedagogical
Sciences
Associate Professor*

MUNICIPAL LEGAL RESPONSIBILITY

Annotation: This article is devoted to the study of municipal and legal responsibility as part of the institution of responsibility of bodies and officials of local government. The analysis of the theoretical provisions and legislation of the Russian Federation regarding the problems of isolation and delineation of municipal and legal responsibility is carried out. The opinion on the representation of municipal legal responsibility as an independent form is supported.

Keywords: legal responsibility, municipal legal responsibility; subjects of municipal legal responsibility.

Согласно Конституции Российской Федерации [1], местное самоуправление является основополагающим элементом конституционного строя, самостоятельной формой народовластия. Законодательное закрепление ответственности органов публичной власти на всех уровнях гарантирует устойчивое положение демократической системы, является гарантией дальнейшего ее развития.

В юридической литературе традиционно выделяют несколько видов юридической ответственности:

- административно-правовая;
- уголовно-правовая;
- гражданско-правовая;
- дисциплинарная.

Такой вид ответственности, как муниципально-правовая ответственность, долгое время наукой не выделялся и не назывался. Однако, в настоящее время ученые не только говорят, но детально исследуют данный вид ответственности.

Стоит отметить, что ни в одном нормативно-правовом акте, действующим на сегодняшний день в системе законодательства Российской Федерации, не раскрывается статус понятия «муниципально-правовая ответственность» ввиду чего основная проблема обособления рассматриваемого понятия как самостоятельного вида состоит прежде всего в определении правой природы муниципально-правовой ответственности, разграничения ее от иных видов юридической ответственности, в частности, от конституционно-правовой. Так, бывший судья Конституционного суда Российской Федерации С.Д. Князев, аргументируя свою позицию на этот счет следующими фактами, что «ни один нормативный правовой акт о местном самоуправлении не раскрывает данное понятие, в отличие от административной, дисциплинарной, уголовной, материальной, гражданской ответственности; процедура ответственности органов и должностных лиц местного самоуправления перед населением и государством принципиально не отличаются от процедуры ответственности органов государственной власти и должностных лиц субъектов РФ, следовательно, выделение муниципально-правовой ответственности от

конституционно-правовой можно считать бессмысленной; исключительно с муниципальным правом не связана и такая мера ответственности, как расформирование избирательной комиссии муниципального образования и досрочное прекращение полномочий ее членов с правом решающего голоса, так как правовые основы закреплены в законодательстве о выборах на федеральном уровне и распространяются на всю структуру избирательных комиссий» [4].

У данной позиции, поддерживаемую многими известными учеными, существует противоположная сторона ее рассмотрения и обсуждения другими оппонентами, в задачу которых входит дифференциация муниципально-правовой и конституционно-правовой ответственности. Как пишет И.А. Алексеев: «Муниципально-правовая ответственность особый вид юридической ответственности, направленный на охрану интересов населения муниципального образования, законных интересов доминирующей части местного сообщества, данный вид ответственности обеспечен специальным набором санкций, применяемых к специальному субъекту (выборным, должностным лицам и органам местного самоуправления) за совершение особого вида правонарушения – муниципального правонарушения» [3].

Таким образом, муниципально-правовая ответственность – это самостоятельный вид юридической ответственности. Муниципально-правовая ответственность наступает за реализацию задач и функций, которые возлагает законодательство на органы и выборных должностных лиц местного самоуправления.

Муниципально-правовая ответственность как особый институт права дает определенную гарантию применения муниципально-правовых санкций к выборным органам власти. Данное обстоятельство лишь указывает на непосредственное участие граждан в реализации основ местного самоуправления. Федеральный закон от 06.10.2003 № 131-ФЗ «Об общих принципах организации местного самоуправления в Российской Федерации» (далее – ФЗ «Об общих принципах организации местного самоуправления в Российской Федерации») закрепляет, что органы и должностные лица органов местного самоуправления несут ответственность перед населением муниципального образования, государством, физическими и юридическими лицами [2]. Стоит отметить, что основания и порядок ответственности законодатель в указанном федеральном законе детально не определяет, что дает возможность муниципальным образованиям самостоятельно решать данные вопросы, устанавливая их в своих уставах.

Придерживаясь точки зрения, что муниципально-правовая ответственность может существовать в дальнейшем, как самостоятельный вид ответственности, следует отметить ее особенности:

Во-первых, муниципально-правовая ответственность

материализуется в форме правового отношения, являющегося, следствием обнаружения муниципального правонарушения. Сторонами такого правонарушения являются:

- орган либо должностное лицо местного самоуправления, совершившее правонарушение;
- представитель власти, в чьи полномочия входит привлечение к муниципально-правовой ответственности;
- субъекты, интересы которых были нарушены в следствие совершения правонарушения (население муниципального образования, государство, физические и юридические лица).

Во-вторых, муниципально-правовая ответственность является формой государственного принуждения.

В-третьих, муниципально-правовая ответственность реализуется согласно с закрепленным на законодательном уровне процессуальным порядком.

В-четвертых, привлечение органов (должностных лиц) местного самоуправления к муниципально-правовой ответственности имеет свои цели:

- охрана личности от противоправных посягательств;
- поддержание правопорядка в обществе, государстве;
- восстановление социальной справедливости, то есть восстановление прав, которые были нарушены в следствие совершения правонарушения;
- предупреждение совершения правонарушения вновь как субъектом, уже совершившим его, так и иными лицами [5].

Спецификой муниципально-правовой ответственности является то, что она развивается внутри публичного права, поскольку государство также осуществляет контроль за развитием местного самоуправления как одной из основ конституционного строя. Нормы конституционного и муниципального права устанавливают не только карательные меры, но и стимулирующие, и в этой связи возникает вопрос о соотношении негативной и позитивной муниципально-правовой ответственности. С учетом всех обозначенных выше обстоятельств необходимым и актуальным представляется формирование современной концепции муниципально-правовой ответственности и отражение ее в законодательстве.

На основании вышесказанного, следует сделать вывод о том, что муниципально-правовая ответственность – это самостоятельный вид юридической ответственности, планомерное развитие которой свидетельствует о наличии достаточных оснований для выделения ее в качестве особого института отрасли муниципального права. Однако, в законодательстве Российской Федерации имеется ряд неразрешенных коллизий в правовом регулировании муниципально-правовой ответственности, в частности, неопределенно понимание сущности и правовой природы муниципально-правовой ответственности, субъекты

муниципальной ответственности весьма неоднозначны. Обусловлено это тем, что общественные отношения, возникающие в сфере муниципальной ответственности органов местного самоуправления и должностных лиц местного самоуправления, являются относительно новыми для российской правовой действительности и, несмотря на имеющийся законодательный и правоприменительный опыт реализации норм муниципально-правовой ответственности.

Использованные источники:

1. Конституция Российской Федерации (с учетом поправок, внесенных Законами РФ о поправках к Конституции Российской Федерации от 30 октября 2008 г. № 6-ФКЗ, от 30 декабря 2008 г. № 7-ФКЗ, от 5 февраля 2014 г. № 2-ФКЗ, от 21 июля 2014 г. № 11-ФКЗ, от 14 марта 2020 № 1-ФКЗ) // Российская газета. – 2020. – 04 июля.
2. Федеральный закон от 06.10.2003 № 131-ФЗ (ред. от 09.11.2020) «Об общих принципах организации местного самоуправления в Российской Федерации» // Собрание законодательства РФ. – 2003. – № 40. – Ст. 3822.
3. Алексеев И.А. Муниципально-правовая ответственность: проблемы исследования на современном этапе / И.А. Алексеев // Гуманитарные и юридические исследования. – 2013. – № 3. – С. 8-11.
4. Князев С.Д. Конституционная ответственность в муниципальном праве: вопросы теории и практики / С.Д. Князев // Журнал российского права. – 2013. – № 6. – С. 83-87.
5. Соколовская Ю.Г. Особенности муниципально-правовой ответственности органов и должностных лиц местного самоуправления / Ю.Г. Соколовская // В сборнике: Молодёжь Сибири – науке России. Материалы международной научно-практической конференции. – 2020. – С. 284-286.

*Орипова Н., кандидат педагогических наук
доцент
заведующий кафедрой дошкольного образования
Каршинский государственный университет
Узбекистан
Нарзиева Л.
студент магистратуры
Каршинский государственный университет*

СОЦИАЛЬНО-ИСТОРИЧЕСКИЕ И ПЕДАГОГИЧЕСКИЕ ПРОБЛЕМЫ ОВЛАДЕНИЯ ПРОФЕССИЕЙ

Аннотация: В данной статье представлен анализ социально-исторических и педагогических проблем овладения профессией, а также философских, педагогических подходов к овладению профессией во взглядах ученых из народной педагогики и Центральной Азии.

Ключевые слова: профессия, Авесто, хадисы, наука, честность, религия, этика.

*Oripova N., candidate of Pedagogical Sciences
Associate Professor
Head of the Department of Preschool Education
Karshi State University
Uzbekistan
Narzieva L.
master's degree student
Karshi State University.*

SOCIO-HISTORICAL AND PEDAGOGICAL PROBLEMS OF PROFESSIONAL DEVELOPMENT

Abstract: This article presents an analysis of socio-historical and pedagogical problems of mastering a profession, as well as philosophical, pedagogical approaches to mastering a profession in the views of scientists from folk pedagogy and Central Asia.

Keywords: profession, Avesto, hadith, science, honesty, religion, ethics.

Многовековой исторический опыт показывает, что во все времена одной из основных задач общества было обучать молодых людей профессии и побуждать их к честной жизни в избранной профессии. В частности, узбекский народ имеет богатый исторический опыт в этой области. Первоначально уникальное решение этой проблемы было искусно описано

в узбекской народной педагогике. Например, в таких пословицах, как «Учитель больше отца твоего», «Родители рожают ребенка, а учитель поднимает его на высоту, в небо», «Ученик, не видевший учителя, ходит на все позиции». достоинство уважается.

Позже этот вопрос стал более отшлифованным в письменных источниках. Например, священная книга зороастризма, Авесто, на протяжении веков была главным руководством для обучения молодежи. Каждый должен быть воспитан таким образом, говорит Авеста, что он должен сначала научиться хорошо читать, затем писать, а затем подняться на высший уровень. Согласно этой доктрине, религиозное воспитание детей начинается с 7 лет. В это время учителя играли важную роль в духовной жизни общины. В обучении детей эффективно использовались демонстрационные инструменты, рассказывание историй и беседа. Самое главное, акцент делается на развитии у детей трудолюбия и профессиональных навыков с раннего возраста. С раннего возраста их учили сажать деревья, делать предметы домашнего обихода, обрабатывать землю и разводить скот [1].

Точно так же в исламском учении главная задача - обучить подрастающее поколение, научить его жить честно, упорным трудом и профессией. В частности, в хадисах человеческие качества интерпретируются как признак духовной зрелости наряду с воздержанием, нечистотой и честностью. В то же время хадисы учат, что честность в профессии, как и честность во всех аспектах, доставляет людям счастливые моменты: «Самое чистое, что человек ест, - это то, что он ест своей профессией» или «Лучшая из профессий - это ручной труд, если он искренен. [3,8].

В то же время хадисы говорят о награде честной профессии: «Если человек зарабатывает честной профессией и дает от нее милостыню, он получит награду и благословение. Но если он зарабатывает богатство нечестным образом и делает эти вещи (садака, инфак) или оставит это позади, это только усилит адский огонь для него» [2,6].

В целом, проблема направления молодых людей в учении ислама к профессии и поощрения их к честной жизни через выбранную профессию также важна для образования современной молодежи. Уникальная педагогическая интерпретация этого вопроса была в центре внимания восточных мыслителей. В частности, Абу Наср аль-Фараби в своих произведениях считает, что для того, чтобы каждый был человеком, достойным общества и государства, он должен иметь профессию и работать в этой профессии честно и искренне. Например, ученый, по его мнению, предъявляет ряд требований к каждому профессионалу. Например, он предъявляет следующие требования к главам государств: «Никто не может руководить городом-государством. Две предпосылки для того, чтобы стать лидером:

1. Человеческая природа - способность руководить (духовная и умственная зрелость).

2. Такого человека должны уважать люди за его высокий статус, человеческие качества и способности. Также важно приобретение опыта лидерства [3].

По словам Абу Али ибн Сины (980-1037), воспитание - это уникальный процесс, который включает в себя умственное, физическое, моральное и профессиональное образование молодых людей. В Законе о медицине говорится о передаче ребенка учителю для обучения и воспитания с шести лет. Ибн Сина считает, что в процессе обучения необходимо соблюдать следующие правила: переходить от простого к сложному в обучении; учет способностей и склонностей ребенка; выполнять упражнения, придающие ребенку силы; совмещение обучения с упражнениями [4].

В «Кобуснаме» Кайковус (11 век) предостерегает своего сына, подчеркивая важность профессии: «О дитя, берегись, что человек без профессии всегда бесполезен и никому не приносит пользы. Знаете, у хора есть тело, но нет тени. Вторая глава «Кобуснаме», такая как «О профессиях и профессионалах», в которой автор останавливается на работе разных профессий, также не приносит пользы ни ему самому, ни кому-либо другому»[4]. Кайковус признает потребность в знаниях для приобретения профессии и трудность получения этих знаний: «... И если учителя, которые учат каждой науке, бьют (ребенка) за образование, вы (отец) должны проявить милосердие, позвольте им ударить, почему мальчик изучает науку и манеры с палкой, а не учится добровольно. Но если ребенок груб и вы злитесь из-за этого, не бейте его рукой, угрожайте учительской палкой. Пусть учителя наказывают детей, чтобы вы не сердились на своего сына»[5,7].

Алишер Навои - один из ученых, высоко ценивших роль профессии и труда в воспитании подрастающего поколения. Поэтому герои его произведений - люди, заработавшие репутацию своим трудом и профессией. Люди честны, и он считает, что люди, особенно учителя, должны любить свою профессию и своих учеников. Он говорит своим ученикам быть требовательными. Педагог подчеркивает, что престижного в обществе человека нужно уважать и уважать [9-13].

В заключение следует отметить, что проблема профессиональной подготовки молодежи - это не только проблема сегодняшнего дня, но и проблема с давней историей. Ведь главная задача педагогического процесса - внимательно изучить секреты профессии, чтобы работать эффективно и осмысленно, побудить их следовать учениям учителей.

Использованные источники:

1. Йулдошев Т. Б. и др. АВЕСТО."Культурная жизнь" // Интернаука. – 2019. – №. 18-1. – С. 57-58.

2. Ободжон Мирхамидов. Ҳалол кас-хунар – кут-барака келтирар. Т.: Мовороуннаҳр, 2018, 15.64.
3. Forobiy A. N. Fozil odamlar shahri // Т.: А. Qodiriy nomidagi halq merosi. – 1993.
4. Ibn Sino A. A. Tib qonunlari //А. Qodiriy nomidagi xalq merosi nashr. Toshkent. – 1992.
5. Кайковус Унсурулмаоли. Кайковус. – Т. – “Истиклол”. – 1994. й 26
6. Nurullayeva S. H. Pedagogical cooperation in higher education //Современное музыкальное образование: традиции и инновации. – 2016. – С. 43-46.
7. Нуруллаева Ш. У. Технологии формирования профессиональных навыков у будущих преподавателей //Подготовка профессиональных управленческих кадров: опыт, проблемы, инновационные образовательные технологии. – 2014. – С. 60-64.
8. Орипова Н. Х., Келдиярова В. Б. Формирование образного мышления учеников начальных классов через интеграционное обучение //Журнал научных публикаций аспирантов и докторантов. – 2018. – №. 7. – С. 43-45.
9. Khalilovna, O. N., Axmatjanovna, M. M., Kosimovich, N. U., Botirovna, K. V. Main core and meaning of shaping professional faith //Journal of Critical Reviews. – 2020. – Т. 7. – №. 2. – С. 242-245.
10. Botirovna K. V. Methods of using oral folk creativity to shape the thinking of preschool children //ACADEMICIA: An International Multidisciplinary Research Journal. – 2020. – Т. 10. – №. 5. – С. 608-612.
11. Орипова Н. Х., Ашурова С. Б. Современные методы формирования мировоззрения детей дошкольного возраста //Журнал научных публикаций аспирантов и докторантов. – 2018. – №. 7. – С. 46-48.
12. Орипова Н. Х., Мухаммадиева А. Способы обучения креативности детей дошкольного возраста //Science And World. – 2013. – С. 50.
13. Орипова Н. Х., Келдиярова В. Б. Формирование образного мышления учеников начальных классов через интеграционное обучение //Журнал научных публикаций аспирантов и докторантов. – 2018. – №. 7. – С. 43-45.

*Османов Р.Т.
студент аспирантуры кафедры финансов и кредита
Институт экономики и управления
ФГАОУ ВО «Крымский федеральный университет
имени В. И. Вернадского»
г. Симферополь*

МЕТОДЫ СОЦИАЛЬНО-ЭКОНОМИЧЕСКОГО РАЗВИТИЯ СЕЛЬСКИХ ТЕРРИТОРИЙ

Аннотация: В статье раскрываются методы социально-экономического развития сельских территорий. Формы государственной поддержки.

Ключевые слова: Сельское хозяйство, развитие, сельская местность, сельские территории, меры поддержки, государственная программа.

*Osmanov R. T.
post-graduate student of the department
of Finance and Credit
Institute of Economics and Management
V.I. Vernadsky Crimean Federal University
Simferopol*

METHODS OF SOCIO-ECONOMIC DEVELOPMENT OF RURAL AREAS

Abstract: The article reveals the methods of socio-economic development of rural areas. Forms of state support.

Keyword. Agriculture, development, rural areas, rural territories, support measures, state program.

ОСНОВАННАЯ ЧАСТЬ. Развитие сельских территорий является важнейшим социально-экономическим и экологическим потенциалом нашего социума. На селе сконцентрированы значительные человеческие, природные и производственные ресурсы, а также отрасли, эффективное развитие которых, может существенно улучшить состояние экономики и поднять уровень жизни населения государства. Если применять к Республике Крым и к Российской Федерации в целом под сельской местностью или сельской территорией принимается территория вне границ городских поселений, включающая всю территорию сельских поселений и межселенную территорию [1,6].

В Крыму насчитывается 1019 населённых пунктов, в том числе 16 городских населённых пунктов и 1003 сельских населённых пунктов, в том числе 56 поселков городского типа, которые учитываются как сельские населённые пункты и 947 сёл и посёлков. Таким образом, можно считать целесообразным создавать все условия для развития именно сельских территорий Республики Крым.

Единицы административно-территориального и населённые пункты	Количество единиц АТД и НП	Единицы муниципального самоуправления
Административные районы	14	Муниципальные районы
Города республиканского значения с подчинёнными им территориями	11	Городские округа
в т.ч.: городские районы	3	
Город в подчинении города республиканского значения	1	
Города районного подчинения	4	Городские поселения
Поселки городского типа	56	Сельские поселения
Сельские населённые пункты	947	

Таб. 1 Количество административно-территориальных единиц в сопоставлении с муниципальными единицами

С целью создания комфортных условия для жителей сел Республики Крым правительством республики принимаются значительные меры, а также принимают активное участие в различных программах предусмотренных на развитие сельских территорий РФ. Все вышеуказанные программы принимаются с целью:

- создание комфортных условий жизнедеятельности в сельской местности;
- стимулирование инвестиционной активности в агропромышленном комплексе путём создания благоприятных инфраструктурных условий в сельской местности;

- содействие созданию высокотехнологичных рабочих мест на селе;
- активизация участия граждан, проживающих в сельской местности, в реализации общественно значимых проектов;
- формирование позитивного отношения к сельской местности и сельскому образу жизни.

Для достижения целей вышеуказанных необходима реализация следующих мероприятий:

- улучшение жилищных условий граждан, проживающих в сельской местности, в том числе молодых семей и молодых специалистов;
- комплексное обустройство населённых пунктов, расположенных в сельской местности, объектами социальной и инженерной инфраструктуры: развитие в сельской местности сети общеобразовательных учреждений, фельдшерско-акушерских пунктов и (или) офисов врача общей практики, плоскостных спортивных сооружений, учреждений культурно-досугового типа, развитие в сельской местности газификации, водоснабжения, реализация проектов комплексного обустройства площадок под компактную жилищную застройку в сельской местности;
- грантовая поддержка местных инициатив граждан, проживающих в сельской местности;
- поощрение и популяризация достижений в сфере развития сельских территорий [5].

Государственную поддержку на развитие сельских территорий и агропромышленного комплекса можно разделить на: программы поддержки на федеральном уровне и на программы поддержки на республиканском уровне.

К федеральным программам поддержки можно отнести:

- Развитие отраслей агропромышленного комплекса
- Стимулирование инвестиционной деятельности в агропромышленном комплексе
- Создание системы поддержки фермеров и развитие сельской кооперации
- Устойчивое развитие сельских территорий
- Развитие мелиорации земель сельскохозяйственного назначения России
- Техническая и технологическая модернизация, инновационное развитие.

К региональным программам поддержки относятся:

- Поддержка растениеводства
- Поддержка животноводства
- Развитие малых форм хозяйствования

Развитие прочих направлений, к которым можно отнести компенсацию прямых понесенных затрат на строительство и модернизацию объектов АПК, предоставление субсидий на развитие мелиорации земель сельскохозяйственного назначения Республики Крым и пр.

Одним из самых важных факторов привлечения специалистов в Крымские села является предоставление доступного жилья возможно по договорам социального найма либо в собственность по льготной ипотеке или за счёт государства, но с условиями отработки определённого срока в селе в определённой сфере. Так например в Крыму очень хорошо работает программа «Земский доктор», согласно которой граждане соответствующей профессии - врачи переезжают в сельские регионы, где большая нехватка квалифицированных кадров в сфере медицины. Таким гражданам предлагаются условия, при которых они переезжают и работают по профессии в медицинских учреждениях, больницах, ФАПах и иных учреждениях на территориях сельских поселений и сельских районов. Вышеуказанная выплата предоставляется врачам в возрасте до 50 лет не имеющим не исполненные обязательства по договору о целевом обучении, прибывшим на работу в сельские населенные пункты, либо города с населением до 50 тыс. человек и заключившим трудовой договор с медицинской организацией на условиях полного рабочего дня, с продолжительностью рабочего времени, установленной в соответствии со статьей 350 ТК РФ, на срок не менее 5 лет. Размер такой выплаты составляет 1 млн. руб., которые гражданин, получивший данную выплату, может использовать на абсолютно любые цели по своему усмотрению.

Также подобная программа действует в сфере образования. Данная программа имеет название «Земский учитель». Условия данной программы схожи с вышеописанной, только гражданам, с соответствующим образованием, требуется устроиться на работу в сфере образования на работу в сельские населенные пункты, либо города с населением до 50 тыс. человек и заключившим трудовой договор с образовательной организацией на срок не менее 5 лет.

Сейчас ведутся разработки программы «Земский строитель», которая направлена на стимулирование привлечения в малые населенные пункты, сельские поселения квалифицированных работников строительных специальностей. По нашему мнению, строители являются не менее дефицитными кадрами в сёлах и малых городах Республики Крым, при условии «большой» стройки, которая инициирована Федеральной целевой программой «Социально-экономическое развитие Республики Крым и г. Севастополя до 2024 года». Строительство новых объектов здравоохранения и образования на территории сел и малых городов и запуск их в эксплуатацию само по себе повлечёт дефицит квалифицированных кадров в вышеуказанных сферах, который и так имеется на сегодняшний день.

На данном этапе социально-экономическое развитие сельских территорий, а также аграрная политика Республики Крым и Российской Федерации в целом ориентирована на улучшение и совершенствование состояния сельских территорий. Это направление отражено в совершенствовании социальной политики и социальной поддержки работающего сектора сельского населения. Также необходимо не забывать о занятости населения на селе, уменьшения безработицы является одним из приоритетных направлений социальной политики Республики Крым.

Развитие сельских территорий подразумевает наличие источников финансирования, внедрение инноваций, создание условий для совершенствования уровня жизни при интенсивном участии органов всех уровней власти. Данные меры позволят улучшить доступ к продуктам питания, уменьшит безработицу на селе, увеличит доходы населения и т. д. Все это будет содействовать притоку населения и совершенствования финансового положения села [6].

Использованные источники:

1. Гольшев М. Е. Сущность устойчивого развития сельских территорий // Вестник НГИЭ. 2011. № 2 (3).
2. Терновых К. С., Нечаев Н. Г., Черных А. Н. Развитие сельских территорий в системе инновационных преобразований АПК // Вестник ОрелГАУ. 2011. № 5. С.45–48.
3. Матвеев Д. М. Управление технологическими процессами как основа развития сельскохозяйственных предприятий / Д. М. Матвеев // Вестн. Новосиб. гос. аграр. ун-та. — 2008. № 8. — С. 60–65.
4. Матвеев Д. М. Управление технологическими процессами в сельскохозяйственных организациях / Т. А. Стадник, А. Т. Стадник, Д. М. Матвеев. — Новосибирск, ЭКОР-книга, 2011. — 245 с.
5. Постановление Правительства РФ от 15 июля 2013 г. N 598 "О федеральной целевой программе "Устойчивое развитие сельских территорий на 2014 - 2017 годы и на период до 2020 года", Сайт правительства РФ. Дата обращения 20.12.2020 URL: <http://government.ru/docs/3313>.
6. Развитие сельских территорий: реалии и перспективы / А. П. Печатнова. — Текст : непосредственный // Молодой ученый. — 2014. — № 8 (67). — С. 390-392. — URL: <https://moluch.ru/archive/67/11354/>

УДК: 32. 001.

Отабоева З.Ф.
ассистенти

“Ўзбек тили педагогика ва жисмоний маданият” кафедраси
Андижон қишлоқ хўжалиги ва агротехнологиялар институти
Абдумухтарова Б.
1-босқич талабаси
Андижон қишлоқ хўжалиги ва агротехнологиялар институти

БОШҚАРУВ ТИЗИМИДА НИЗОЛИ ВАЗИЯТЛАР ПСИХОЛОГИЯСИ

Аннотация. Ушбу мақолада бошқарув тизимидаги учраётган турли хил низо ва зиддиятлар тахлили ва келиб чиқиш сабаблари ёритилган. Низоли вазиятларнинг бир нечта турлари келтириб ўтилган. Рахбарлик фаолиятини тўғри ташкил этишида ишни режаслаштириш ва вазифаларни тақсимлаш фикр юритилган.

Калит сўзлар. Низо, зиддият, антогонистик, вертикал, горизонтал, компромисс, потенциал, хиссий-эмоционал, потенциал, Ригид тоифа, ижобий эмоция, объектив, мотивация, оптималлаштириш.

Otaboeva Z.G.
assistant

Department of «Uzbek language pedagogy and Physical Culture»
Andijan Institute of Agriculture and agrotechnologies
Abdumukhtarova B.
Andijan Institute of Agriculture and agrotechnologies

PSYCHOLOGY OF CONFLICT SITUATIONS IN THE MANAGEMENT SYSTEM

Abstract. The article analyzes various conflicts and contradictions encountered in the management system and explains their causes. Several types of conflict situations are given. With the correct organization of management activities, the idea of work planning and division of responsibility is taken into account.

Key words. Conflict, contradiction, antagonistic, vertical, horizontal, compromise, potential, emotional, potential, tough category, positive emotion, goal, motivation, optimization.

Жаҳонда глобаллашув жараёни жадал суръатлар билан кечаётган айни бир пайтда жамоа билан самарали мулоқот ўрната билиш, жамоаларда юз берадиган низоли вазиятларни тўғри тахлил қилиш ҳамда келиб чиқиш сабабларини чуқур ўрганиш бугунги кун психолог ва социологлари олдида

турган муҳим вазифалардан биридир. Зиддият ва низолар инсоният пайдо бўлган даврданоқ мавжуд бўлиб, уни илмий тадқиқот предмети сифатида ўрганиш борасидаги илк қарашлар ҳам ўз тарихига эга. Тобора такомиллашиб бораётган ҳаёт тарзи, меҳнат фаолияти, шахслар аро муносабат муҳитининг ўзгараётганлиги зиддиятларнинг ҳам ўзига хос томонлари мавжудлигини кўрсатмоқда.

Низо лотинча «конфликт» сўзидан олинган бўлиб, «тўқнашиш», яъни зиддият, мақсад, қизиқиш, нуқтаи назар, фикрлар, кишиларнинг ўзаро таъсирлашувидаги қарама-қарши йўналишлар борасида тўқнашишларидан иборат¹

Низо – мулоқот иштирокчиларининг ҳар бири учун муҳим бўлган муаммони ҳал этиш вақтида улар ўртасида вужудга келган қарама-қаршилиқ ва курашнинг кескин кучайиб кетиш жараёнидир.

Инсоний муносабатларнинг ҳар қандай тизимида ҳам фикрларнинг ранг-баранг бўлиши ва улар ўртасида фарқларнинг бўлиши муқаррар ҳолдир. Фикрлар ранг-баранглигининг асосий сабаблари сифатида қуйидагиларни кўрсатиш мумкин:

1. Алоҳида шахс ва жамоатчилик манфаатларининг мос келмаслиги;
2. Айрим алоҳида жамоа аъзолари хатти-ҳаракатларининг ижтимоий, гуруҳий номаларга зид келиши;
3. Ишни ташкил этиш ва меънатга муносабатдаги фарқлар;
4. Ишчи ходимлар ўртасидаги вазифаларнинг тўғри тақсимланмаганлиги.

Низонинг асоси мулоқот иштирокчиларининг бири иккинчисининг ўз эътиёжларини қондириш, ўз мақсадларига эришиш жараёнига тўсқинлик қила бошлаши туфайли пайдо бўлади ва бу низоли вазият сифатида қаралади. Мулоқот иштирокчиларининг ушбу низоли вазиятда вужудга келган тўсқинчи бартараф этиш учун амалга оширувчи ҳаракатлари низони, яъни очиқдан очиқ қарши курашни келтириб чиқаради.

Низоли вазиятларнинг бир нечта турлари мавжуд:

- 1) Таъсирнинг йўналишига кўра: вертикал ва горизонтал низолар;
- 2) Низони ҳал қилиш усулига кўра: антогонистик ва келишувга олиб келадиган низолар – компромисс;
- 3) Намоён бўлиш даражасига кўра: очиқ, яширин, потенциал, асосли.
- 4) Иштирокчилар сонига кўра: шахсий, шахслар аро, гуруҳлар аро;
- 5) Келиб чиқиш табиатига кўра: миллий, этник, миллатлар аро, ишлаб чиқариш, ҳиссий-эмоционал.

Агар юқоридагиларни таҳлил қиладиган бўлсак, “горизонтал низолар” ҳаётда энг кўп учрайди. Бундай номуросозликлар аксарият ҳолларда ходимлар ўртасида айрим аъзоларнинг ишни яхшилаш, янги иш методларини жорий этиш, ахлоқ нормаларини химоя қилиш, адолат учун кураш, илғор жамоа аъзоларининг шу ердаги маънавий муҳитни

соғломлаштириш борасидаги фикрларини айримлар томонидан эътирозлар билан қабул қилиши натижасида рўй беради.

Низолар юзга келишида икки хил шарт-шароит мавжуд. Объектив шарт-шароитларга:

- Мехнат қилиш учун шароитнинг ёмонлиги;
- Ходимлар орасида мажбурият ва вазифаларнинг нотўғри тақсимланганлиги;
- Бошқарув тизимидаги номутаносибликлар;
- Қўйилган вазифаларга мос профессионалликни ходимларда кузатилмаслиги;
- Ишчи ўринларининг етишмаслиги туфайли, ишларнинг тақсимланишидаги адолацизлик;
- Мехнатни ташкил этиш ва мехнатга ҳақ тўлашда адолацизлик ҳолатларини кузатилиши.

Низолар юзага келишида субъектив шарт-шароитларга:

- Ишбилармонлик муносабатларида негатив йўлларни кўриниши;
- Шахслар аро муносабатларда шахсга оид хусусиятларнинг намоён бўлиши.
- Муомалани ташкил этишда нўноқлик ва саводсизликнинг кузатилиши.

Низоли ҳолатларда шахснинг қандай ҳулқ-атвор хусусиятларини намоён этишига қараб турли тоифаларини кузатилади. Ф.М.Бородкин ва Н.М.Коряклар низоли вазиятларда олти хил шахс типлари-тоифаларини кўрсатиб берганлар. Булар:

1. Намойишкорона тоифадаги низоли шахс.
2. Ригид тоифадаги низоли шахс.
3. Бошқариб бўлмайдиган тоифадаги низоли шахс.
4. Аниқликни талаб этадиган тоифадаги низоли шахс.
5. Низосиз тоифадаги низоли шахс.
6. Мақсадга йўналтирилган тоифадаги низоли шахс 3.

Бу низоли шахс тоифалари ўзаро муносабатларда намоён бўлар экан, қайси тоифа билан қандай ишбилармонлик муносабатларини ўрнатишга, музокаралар олиб боришга бевосита таъсир этади. Шунинг учун ҳамкорликка киришишда албатта кузатувчан бўлиш, ҳар бир ҳаракат мақсадини англаш малакаларини таркиб топтириш муҳимдир. Бугунги кунда вақт омилининг ахамияти беқиёс даражда. Ҳар дақиқадан унумли фойдаланиш замонавий раҳбар олдида турган долзарб вазифалардан биридир. Дунёнинг машҳур психологлари томонидан ўтказилган тадқиқотлар натижасида фанга “вақт ўғрилари” тушунчаси кириб келди. Раҳбар вақтининг турли хил ҳаётий вазиятларга сарф этилиб, иш самарадорлигига салбий таъсир этувчи омиллар кўпайиб бормақда. Раҳбарни, раҳбар қилиб иш олиб боришига ходимни таъсири катта, чунки

рахбар ва ходим тил топиб ишламас экан олдига кўйилган мақсадга эришиш сустлашади.

Мақсаднинг аниқ эмаслиги, кадриятларнинг йўқлиги, кўп вазифани бир вақтда бажаришга интилиш, вазифаларни бажаришда уларнинг ечимини тўлиқ тасаввур қила олмаслик, иш кунини нотўғри режалаштириш, ўз ўзини бошқара олмаслик “қоғозларга кўмилиб қолиш, тартибсиз ва меъеридан кўп ўқиш, хужжатларнинг ўз вақтида етиб келмаслиги, мотивациянинг етишмаслиги, дангасалик, керакли ахборотнинг яхши сақланмаслиги, ишнинг тўғри тақсимланмаганлиги, ишчи кучининг етишмаслиги, тасодикий телефон кўнғироқлари, режалаштирилмаган келувчилар, ”йўқ” дея олмаслик, тўлиқ бўлмаган ва кечиккан ахборот, тартибнинг йўқлиги, ишни охиригача етказа олмаслик, диққатнинг кўп бузилиши (шовқинлар ва хк...), асабий мажлислар, сухбат ва мажлисларга яхши тайёргарлик кўрмаслик, мулоқотнинг йўқлиги ёки қайта алоқанинг ноаниқлиги, шахсий хаёт ҳақида кўп гапириш, ортиқча мулоқатчанлик, иш ёзувларининг кўплиги, ишни “кейин”га қолдириш одати, ҳамма нарсани билишга интилиш, кўп кутиш, сабрсизлик, зерикаш, топширилган вазифаларни қай даражада эканлигини назорат қилмаслик ёки назоратнинг сустлиги натижанинг самарасизлигига сабабдир.

Кўпчилик раҳбарлар ижодий алтернативларни яратишдан кўра муаммоларни ҳал қилишни; воситалардан фойдаланишни оптималлаштиришдан кўра воситаларни тежашни; натижага эришишдан кўра вазифани бажаришни; фойдани кўпайтиришдан кўра зарарни пасайтиришни ўз олдиларига мақсад қилиб қўйишади ва хато қилишади. Бу ўз навбатида ташкилот ёки муассасанинг миссиясига ҳам салбий таъсир этади. Вақт эса ҳеч қачон ортга қайтмайди. Раҳбарлик фаолиятини тўғри ташкил этишда ишни режалаштириш ва вазифаларни тақсимлаш муҳим аҳамиятга эга.

Ишни режалаштириш ва вазифаларни тақсимлашнинг самарали томони шундаки бу режалаштириш вақтдан унумли фойдаланишга олиб келади. Бошқарув фаолиятдан маълумки 10 минутлик тайёргарлик 2 соатлик иш вақтининг беҳуда кетишини олдини олади. Иш кунининг режаси албатта ёзма шаклда бўлмоғи лозим.

Раҳбар фаолиятидаги энг муаммоли масалалардан бири-бу ходимлар билан бўладиган зиддият, низолар. Психологлар мулоқотдаги низоларни олдини олиш учун қуйидаги қоидаларга амал қилиш лозимлигини уқтириб ўтадилар:

- танқид ва айбловни кўп ишлатмаслик, кўп нолийвермаслик;
- фикрни қисқароқ гапларда ифодалаш;
- эътиборли тингловчи бўлиш;
- овознинг имкон қадар самимий жаранглашини таъминлаш;
- қатой фикр билдиришдан сақланиш;
- буйруқ оҳангидан воз кечиш;

- «хеч қачон» ва «хар доим» сўзларидан эътиёткорлик билан фойдаланиш;

- ижобий эмоцияларни сақлаб туриш, кўпроқ табассум қилиш.

Айрим раҳбарлар зиддиятни келиб чиқиш механизмларини чуқур ўрганмайди, баъзилари эса зиддиятдан қочади, бефарқ бўлади. Бу иккала қараш нотўғри. Бефарқлик низоларнинг чуқурлашиб кетишига олиб келади.

Зиддиятлар бошқа шахсларга юқиши “наслдан наслга ўтиши” мумкин. Масалан, айрим ҳолларда ишнинг келажаги учун фойдали бўлиши, айрим низонинг сабаби йўқолса ҳам у қайтадан вужудга келиши мумкин. Низоли вазият ҳолда шахснинг ўзига –соғлиғига зарар бўлиши мумкин. Низодан сўнг кишининг кайфияти пасаяди, қўли ишга бормаслиги мумкин. Зиддиятли вазиятни тўрт қисмга бўлиш мумкин: объектив мақсадга йўналтирилган, объектив мақсадга йўналтирилмаган, субъектив мақсадга йўналтирилган ва субъектив мақсадга йўналтирилмаган. Юқоридаги вазиятда объектив мақсадга йўналтирилган вазият тури амалга оширилган. Объектив зиддият хеч қачон субъектив зиддиятга айланмаслиги керак.

Хулоса қилиб айтганда, низо рўй бергач уларни бартараф этиш учун қуйидагиларга амал қилиш тавсия этилади:

- 1) Вазминликни сақлаб қолиш;
- 2) Низонинг асосий сабабини аниқлашга интилиш;
- 3) Шахсий соҳадаги тўқнашувга йўл қўймаслик;
- 4) Хар бир сўз ва иборадан эътиёткорлик билан фойдаланиш;
- 5) Компромисс учун очик бўлиш;
- 6) Сухбатдошнинг хар бир гапини диққат билан тинглаш ва таҳлил қилиш.

Биз ўзаро мулоқотда низоларнинг пайдо бўлмаслигига ҳаракат қилмоғимиз, сухбатдошимизни тўғри тушунмоғимиз керак. Шундагина атрофдагилар билан бўладиган мулоқотимиз муваффақиятли амалга ошади.

Фойдаланилган адабиётлар:

1. Д.Б.Рахмонова. Бошқарув психологияси фанидан маърузалар матни - Бухоро 2010.
2. Р.Х.Душанов, Ё.А.Парфиев “Касбий психология” Маърузалар курси. Тошкент 2010.
3. Х.Х.Шарофутдинова “Мулоқот психологияси” - Термиз 2008.
4. Педагогика ва психология фанидан маърузалар матни - Тошкент 2010.
5. Ф.А.Акрамова “Ижтимоий психология” – Т. 2007
6. Яровицкий В. “Сто великих психологов” – М.: “Вечер”. 2004

Оглавление

ОСНОВНОЙ РАЗДЕЛ	3
Abdullayeva N.S., THE USE OF AUTHENTIC VIDEO MATERIALS IN THE FORMATION OF STUDENTS' COMMUNICATIVE COMPETENCE IN NON-LANGUAGE HIGHER EDUCATION INSTITUTIONS.....	3
Abduraxmonova S.Sh., Mamasoliyeva Sh.Kh., ASSIGNMENT OF PEOPLE'S FAIRY TALES AND THE FORMATION OF LIBRARY IN CHILDREN THROUGH MASS MEDIA	7
Abdusalomov U.S., Boltaboyev A., GENERAL CHARACTERISTICS OF THE MILITARY COMMITTEES OF THE ARMED FORCES OF THE REPUBLIC OF UZBEKISTAN.....	10
Achilova O.U., “FIZIKA FANIGA HISSA QO'SHGAN OLIMLAR” MAVZUSIDA KONFERENSIYA DARSLARINI TASHKIL ETISH METO‘DIKASI.....	14
Ahmadjonova Sh.N., THE USAGE OF INTERNET TECHNOLOGIES FOR EFFECTIVE FL ACQUISITION	18
Alimova X.T., PROJECT METHOD AS A NEW METHOD OF TEACHING AND LEARNING ENGLISH.....	22
Almatova N.A., PSYCHOLOGICAL FEATURES OF VISUAL AIDS IN TEACHING ENGLISH	26
Amanov A.K., THE ROLE OF SPECIAL ECONOMIC ZONES IN THE ECONOMY: FOREIGN EXPERIENCE AND UZBEKISTAN.....	30
Atakhanova G.O., TEACHING ENGLISH TO BLIND STUDENTS.....	35
Baltabaev O.O., THE ETYMOLOGY OF THE TAKHTAKUPIR TOPONYMY	38
Baxodirova Sh.B., MAKTABGACHA TA’LIM JARAYONIDA BOLALAR OG‘ZAKI NUTQINI TAKOMILLASHTIRISH.....	41
Mekhriban B.B., STYLE AND STYLISTICS: FUNDAMENTALS	47
Bobobekova J.A., Melibayeva M.S., FAMOUS PEOPLE OF UZBEKISTAN.....	51
Bobobekova J.A., Turgunova Sh.J., EDUCATIONAL SYSTEM IN GREAT BRITAIN TYPES OF SCHOOLS	55
Boboyev M.K., HASHIM IBN HAKIM (MUKANNA) AS A HISTORICAL PERSON.....	59
Bohdaniuk O.V., CLASSIFICATION OF INCOME FROM OPERATING ACTIVITIES AS A BASIS FOR THE ORGANIZATION OF ITS ACCOUNTING AND ANALYSIS.....	63

Bokiyev M., Mamazulunov N., SOME BIOLOGICAL ACTIVE PRODUCTS OF METALLOCENES	67
Bozorov E.H., Jo'rayev M.Qa., DUNYODA YADRO ENERGETIKASI TARAQQIYOTI RIVOJLANISHINI AMALIY AHAMIYATINING INNOVATSION TEXNOLOGIYALARDAGI BOSQICHLARI	71
Bozorov E.H., Rustamov S.Sh., DUNYODA YADRO TEXNOLOGIYALARI RIVOJLANISH BOSQICHLARINING PEDAGOGIK TAHLILLAR ORQALI ASOSLASH	77
Choriyeva M.Qi., LIFE AND LITERARY HERITAGE OF ABDURAHMON TAMKIN BUKHARI.....	83
Egamberdiyeva D.U., PROBLEMS OF LEARNING DIALOGUE AND ITS STRUCTURAL COMPONENTS	86
Ergashev A.A., Najmitdinova G.K., FEATURES OF DIFFERENTIATED TEACHING OF CHEMISTRY	89
Fayazov O.A., Kadirova R.A., THE IMPACT OF DECENTRALIZATION OR DELEGATION OF AUTHORITY ON THE REGIONAL DISPARITY.....	93
Gulomjonova M., THE ROLE OF DISTANCE LEARNING IN THE ORGANIZATION OF INDEPENDENT COGNITIVE ACTIVITY OF STUDENTS.....	97
Haknazarova Z.U., AMERICAN HOLIDAYS AND TRADITIONS.....	101
Hamroyeva I.E., TEACHING STRATEGIES FOR YOUNG LEARNERS....	105
Irgashev M.U., SPECIFICITY OF VOCATIONAL TRAINING OF STUDENTS WITH DISABILITIES IN A HIGHER EDUCATIONAL INSTITUTION	109
Isayev A.A., THE IMPACT OF THE GEOGRAPHICAL LOCATION OF THE REPUBLIC OF UZBEKISTAN ON THE FORMATION OF TRANSPORT CORRIDORS	113
Ishankulov Sh.U., Niyozova Yu.T., TEACHING LISTENING COMPREHENSION	117
Ishonkulov Sh.U., Tursuniyozov D.O., TEACHING SPECIFIC ASPECTS OF LANGUAGE.....	124
Izzatillayev A.A., THE IMPORTANCE OF SPEECH ACTS IN ADVERTISEMENT CONCERNING TOURISM.....	128
Sulaymanov S., Kamilov Kh.M., RESULTS OF INTEGRAL SCORE ASSESSMENT OF TRAIN DISPATCHERS BY SERIOUS AND STRENGTH OF WORKING CONDITIONS (ON THE EXAMPLE OF THE SINGLE DISPATCH CENTER OF UZBEKISTAN RAILWAYS JOINT STOCK COMPANY).....	131

Kholmurodova N.Sh., PILGRIMAGE SITE "KHUZHAI SAROB ATA"	135
Khusainov O.Dj., SOCIO-ECONOMIC CHARACTERISTICS OF THE DEVELOPMENT OF THE INFRASTRUCTURE SYSTEM PROVIDING SERVICES TO THE LIVESTOCK NETWORK IN THE CONDITIONS OF INNOVATIVE ECONOMY	137
Kolesnikova Yu.S., DIGITALIZATION OF INDUSTRY AS A VECTOR OF A NEW DIGITAL SPACE	141
Kulliyev O.A., Jiyanov L.N., INNOVATIVE DEVELOPMENT AND AGRICULTURAL APPROACH TO AGRICULTURE.....	148
Kurbonov A.B., Jalilova N.M., Safarov K.B., DIRECTIONS FOR THE FORMATION OF COOPERATION IN THE FIELD OF AGRICULTURAL ENTREPRENEURSHIP	151
Majidova Z.A., THE STAGES OF DEVELOPMENT OF E-LEARNING, TECHNOLOGIES OF DISTANCE LEARNING	157
Makhammadjonov T.A., Makhammadjonova F.A., Tajiddinov S.S., SUBJECT AND TASKS OF BIOLOGICAL CHEMISTRY.....	160
Mamajonova G.A., Kholmatova M.A., Saidnazarova T.M., HISTORY OF TECHNOLOGICAL SCIENCE AND DEVELOPMENT STRATEGY	163
Mamatov R.R., USING INFORMATION TECHNOLOGY AND EDUCATIONAL ELECTRONIC RESOURCES WHILE PLANNING A FOREIGN LANGUAGE LESSON	167
Matkarimova G., ANALYSIS OF PEDAGOGICAL ACTIVITY IN CONDUCTING DIDACTIC GAMES IN ENGLISH LESSONS IN ORDER TO INCREASE INTEREST IN THE SUBJECT	171
Mukhammadiyeva Kh.K., DEVELOPING INTELLIGENCE IN PRESCHOOL CHILDREN THROUGH THE USE OF PERSON-CENTERED TECHNOLOGIES.....	174
Muxitdinova F.R., EXPERIMENTAL WORK ON USING NEW INFORMATION TECHNOLOGIES IN THE PROCESS OF LEARNING A FOREIGN LANGUAGE	177
Nasriyeva D.A., L'EPOQUE DES LUMIERES EST UN RENNAISSANCE DE LA SOCIETE FRANÇAISE.....	181
Nishonova K.Sh., DIDACTIC OPPORTUNITIES FOR PROFESSIONAL SOCIALIZATION OF FUTURE PRIMARY SCHOOL TEACHERS	183
Normamatov I.B., REDUCTION OF EXTERNAL BANK CIRCULATION OF CASH AS A COMPULSORY CONDITION IN DEVELOPMENT OF PAYMENT BY CHEQUE IN COUNTRIES OF CIS.....	187

Nosirova M.K., PRACTICAL USE OF TEACHING METHODS FOR TEACHING GERMAN IN THE LESSON.....	192
Nuritdinova Yo.A., THEORETICAL FOUNDATIONS FOR THE IMPLEMENTATION OF THE PROBLEMATIC APPROACH IN TEACHING FOREIGN LANGUAGES AT SCHOOL.....	196
Ochilova M.Sh., ALISHER NAVOI'S MYSTICAL VIEWS ON THE RELATIONSHIP BETWEEN THE UNIVERSE AND MAN (ON THE EXAMPLE OF "SAB'AYI SAYYAR").....	200
Ochilova N.S., ORGANIZATION OF THE EDUCATIONAL PROCESS USING DISTANCE LEARNING	203
Odilova N.A., USE OF INNOVATIVE METHODS IN PROFESSIONAL DISCOURSE OF A TEACHER OF FOREIGN LANGUAGES	207
Ostonova R.F., MOTIVATIONAL IMPACTS FOR EFFECTIVE VIRTUAL TEACHING AND LEARNING	212
Pirnazarova R., SATIRICAL JOURNALISM, ENVIRONMENTAL PROBLEMS AND THE VALUE OF WATER	216
Polvonov Kh.N., Khamrayev J., Jurakulov Sh.B., THE STRUCTURE AND FUNCTIONS OF CLOUD PRODUCTION.....	220
Polvonov X.M., KALSIY XLORAT DEFOLIANTINI OLIHDA TEXNOLOGIK HISOBLAR	224
Pulatova M., APPLICATION OF ENCARSIA PARASITE AGAINST TYPES	231
Qiryigitov B.A., CHARACTERIZATION DIFFERENT METHODS OF APPROXIMATION AND INTERPOLATION AND THEIR IMPLEMENTATION IN MATHCAD AND MATLAB	234
Qodirova G.T., THE MODERN METHODS OF TEACHING BASIC LANGUAGE SKILLS	237
Qoraboyeva N., THE ROLE OF FUNCTIONAL-COGNITIVE DICTIONARY IN DESCRIBING VARIOUS PHRASEOLOGICAL LEVELS	241
Sadullaev B.A., Astanaliev E.T., JAPANESE METHOD FOR FORMATION OF MULTI-GROUP TRAINS.....	245
Shaniyazova D.S., THE ROLE OF SPEECH IN IMPROVING THE PROFESSIONAL COMPETENCE OF A PRIMARY SCHOOL TEACHER	249
Shokhuzhaeva Z.S., Donaeva F.B., EFFECTIVENESS OF AGRARIAN AND ECONOMIC REFORMS IN AGRICULTURE OF UZBEKISTAN	252
Samira Yaser Shomul, ANALYZING THE REALITY OF THE TOURISM SECTOR IN SYRIA BETWEEN BEFORE AND DURING THE CRISIS (2011-2018).....	258

Sodiqova G.G'., BOSHLANG'ICH SINIF O'QUVCHILARINING MUSTAQIL O'QISH KO'NIKMALARINI SHAKLLANTIRISH METODIKASI METHODOLOGY OF INDEPENDENT READING SKILLS FOR PRIMARY SCHOOL STUDENTS	267
Tojibaeva N., ENSURING FINANCIAL SUSTAINABILITY OF FARMS IN UZBEKISTAN.....	271
Turdimambetov I.R., Uzaqbaev Q.K., Oteuliev M.O., TERRITORIAL FORMATION OF THE EDUCATION SYSTEM IN IMPROVING THE QUALITY OF LIFE OF THE POPULATION OF THE REPUBLIC OF KARAKALPAKSTAN	276
Turopova L.S., Ismoilova M.K., TEACHING GRAMMAR CREATIVELY AT ELEMENTARY LEVEL	280
Umarova R.U., TA'LIM TIZIMIDA SMART TEXNOLOGIYASIDAN FOYDALANISH SAMARADORLIGINI OSHIRISH.....	288
Usmonova Sh.R., THE USE OF MODERN EDUCATIONAL AND INFORMATION AND COMMUNICATION TECHNOLOGIES IN THE PROCESS OF TEACHING ENGLISH LANGUAGE	293
Yusupov R.M., Yusupova U.K., RULE OF LAW IN HISTORICAL DEVELOPMENT	297
Amanov O.A., THE IMPORTANCE OF DIGITAL TECHNOLOGIES IN ENSURING EMPLOYMENT.....	302
Абакаров Ш.М., ОСНОВНАЯ ПРОБЛЕМА В ЗДРАВООХРАНЕНИИ РФ.....	315
Абдурахманова А.М., НОРМАТИВНО-ПРАВОВОЕ РЕГУЛИРОВАНИЕ ВЗЫСКАНИЯ НАЛОГОВОЙ ЗАДОЛЖЕННОСТИ В СОВЕТСКИЙ ПЕРИОД.....	319
Абдурахманова А.М., ЭКОНОМИКО–ПРАВОВОЕ ЗНАЧЕНИЕ НАЛОГОВОЙ ЗАДОЛЖЕННОСТИ.....	324
Абдурахмонов А., Сайпиддинов Ш., РЕНТАБЕЛЬНОСТЬ, ПОЛУЧЕННАЯ ОТ ИСПОЛЬЗОВАНИЯ ХЛОПКО ОЧИСТКИ В ПРОИЗВОДСТВЕ.....	329
Абброва Н.Ф., ОПРЕДЕЛЕНИЕ ПАДЕЖА И ПАДЕЖНЫХ ОКОНЧАНИЙ В КОРЕЙСКОМ ЯЗЫКЕ	333
Авезимбетов Ш.Д., МЕТОДЫ ЛЕЧЕНИЯ И ЛАБОРАТОРНОЕ ИССЛЕДОВАНИЕ СЕКРЕТНОГО ХРОНИЧЕСКОГО ЭНДОМЕТРИТА	338
Айвазян А.Л., УПРАВЛЕНИЕ НАЛОГОВЫМИ РИСКАМИ НА ПРЕДПРИЯТИЯХ ПИЩЕВОЙ ПРОМЫШЛЕННОСТИ	342

Аймуханова С.А., МЕТОДИКИ АНАЛИЗА ДЕБИТОРСКО-КРЕДИТОРСКОЙ ЗАДОЛЖЕННОСТИ	346
Акрамова Ш.Г, ПОЛОЖЕНИЕ ЖЕНЩИН НА РЫНКЕ ТРУДА В РЕСПУБЛИКЕ УЗБЕКИСТАН В СВЕТЕ ГЛОБАЛЬНЫХ ТЕНДЕНЦИЙ	351
Алимова Д., АНАЛИЗ ПОНЯТИЯ "ВЕЖЛИВОСТЬ" В КОРЕЙСКОМ И РУССКИХ ЯЗЫКАХ	361
Аманов О.А., Жонузоков Н.Б., ВЛИЯНИЕ ЦИФРОВОЙ ЭКОНОМИКИ НА РЫНОК ТРУДА	365
Аманов О.А., Чуллиев Ж.К., ПОВЫШЕНИЕ ЭФФЕКТИВНОСТИ ИСПОЛЬЗОВАНИЯ ЧЕЛОВЕЧЕСКОГО КАПИТАЛА	373
Арутюнян Д.В., Брюханова Г.Д., ЭКОЛОГЧЕСКИЙ ТУРИЗМ КАК ФАКТОР УСТОЙЧИВОГО РАЗВИТИЯ	378
Асадуллаева Д.А., Каландаров М.М., ИЗУЧЕНИЕ ИНТРОДУКЦИИ КИПАРИСА ВЕЧНОЗЕЛЕННОГО В УСЛОВИЯХ УЗБЕКИСТАНА	382
Асронов Э.К., Солиева М.Б., ВЛИЯНИЕ ИЗМЕНЕНИЯ ТЕМПЕРАТУРЫ НА ПРОДУКТИВНОСТЬ И КАЧЕСТВО КОКОНОВ ВО ВРЕМЯ КОРМЛЕНИЯ ТУТОВОГО ШЕЛКОПРЯДА	388
Ахунбаев А.А., Ражабова Н.Р., Вохидова Н.Х., ИССЛЕДОВАНИЕ ГИДРОДИНАМИКИ РОТОРНОЙ СУШИЛКИ С БЫСТРОВРАЩАЮЩИМСЯ РОТОРОМ	392
Базаров А.А., РТУТЬ В ПОДЗЕМНЫХ И ПОВЕРХНОСТНЫХ ВОДАХ БУХАРО-КАРШИНСКОЙ НЕФТЕГАЗОНОСНОЙ ОБЛАСТИ	397
Базикян М.А., АКТУАЛЬНЫЕ ВОПРОСЫ ЭКОНОМИКИ ПРИ ГРАДОСТРОИТЕЛЬСТВЕ	402
Баязитова Р.Н., РАЗВИТИЕ НЕФТЕГАЗОВОГО СЕКТОРА РЕСПУБЛИКИ БАШКОРТОСТАН	406
Бичурина И.Р., ПРОБЛЕМА ПАССИВНОЙ ЗАЩИТЫ В УГОЛОВНОМ ПРОЦЕССЕ	410
Богомазова В.А., СИСТЕМА ОРГАНИЗАЦИИ ИННОВАЦИОННОЙ ДЕЯТЕЛЬНОСТИ В КОМПАНИЯХ КОРПОРАТИВНОГО ТИПА	413
Борисов А.В., Вахрамеев Ю.В., Житков Д.С., ОТЛИЧИЯ ПОРЯДКА ОБРАЗОВАНИЯ, ОРГАНИЗАЦИИ И КОМПЕТЕНЦИИ ЗАТО И МО ...	417
Боташева А.Д., Бадахова И.Т., ВЛИЯНИЕ ПАНДЕМИИ COVID-19 НА СМЕЩЕНИЕ ПОЗИЦИИ МАЛОГО ПРЕДПРИНИМАТЕЛЬСТВА НА ВНУТРЕННЕМ РЫНКЕ РОССИЙСКОЙ ФЕДЕРАЦИИ	423
Бочков П.В., Первушин К.В., ОСНОВНЫЕ ПРОБЛЕМЫ БЕЗОПАСНОСТИ МУНИЦИПАЛЬНЫХ ГОРОДСКИХ ОКРУГОВ	429

Буркут А., ОСОБЕННОСТИ ОТРАЖЕНИЯ В БУХГАЛТЕРСКОМ УЧЕТЕ ОПЕРАЦИЙ ПО ОПЛАТЕ ТРУДА.....	433
Васильева Т.И., КРАТКИЕ ЗАМЕТКИ ОБ ОРКЕСТРОВОЙ ДРАМАТУРГИИ В «РЕКВИЕМЕ» ВЯЧЕСЛАВА АРТЁМОВА	440
Винокуров А.О., КУРОРТНЫЙ СБОР.....	447
Гадоев А., Шарипова Б., Гадоева Г., Комилова Х., ЗАРАЖЕННОСТЬ ДОМАШНИХ ЖИВОТНЫХ САРКОСПОРИДИЯМИ В ЗАВИСИМОСТИ ОТ ВОЗРАСТА.....	451
Гадоев А., Туркистанова М., Гадоева Г., Комилова Х., ЗАРАЖЕННОСТЬ ДОМАШНИХ ЖИВОТНЫХ САРКОСПОРИДИЯМИ В ЗАВИСИМОСТИ ОТ ПОЛА	454
Ғойипов А.Р., Нормуродов И.Ў., Таджиходжаева У.Б., МОДИФИЦИРЛАНГАН ФЕНОЛ-ФОРМАЛЬДЕГИД ОЛИГОМЕРЛАРИНИ ТИКИЛИШ ШАРОИТЛАРИНИ ФЕНОЛОСПИРТ ТАРКИБИГА БОҒЛИҚЛИГИНИ ЎРГАНИШ	457
Гайсина А.В., СТРАТЕГИЯ РАЗВИТИЯ ЭКОНОМИЧЕСКОЙ ДЕЯТЕЛЬНОСТИ ПРЕДПРИЯТИЯ ТОО «ОМАС ИНТЕГРЕЙТЕД».....	462
Гильманова Р.Р., ОСОБЕННОСТИ НАЛОГООБЛОЖЕНИЯ ИНДИВИДУАЛЬНОГО ПРЕДПРИНИМАТЕЛЯ.....	466
Гильманова Р.Р., ПРЕДЪЯВЛЕНИЕ ДЛЯ ОПОЗНАНИЯ.....	470
Головин А.А., Скиба М.С., КАЧЕСТВО ОКАЗАНИЯ МУНИЦИПАЛЬНЫХ УСЛУГ НАСЕЛЕНИЮ И ПУТИ ЕГО СОВЕРШЕНСТВОВАНИЯ	473
Горбачева Н.А., Родионова Т.С., СОВЕРШЕНСТВОВАНИЕ СИСТЕМЫ БЕЗНАЛИЧНЫХ БАНКОВСКИХ РАСЧЁТОВ	477
Горбулинская А.П., СУЩНОСТЬ ПОНЯТИЯ ФИНАНСОВОЕ СОСТОЯНИЯ ОРГАНИЗАЦИИ.....	481
Григорян А.Р., ПРИМЕНЕНИЕ CRM-МАРКЕТИНГА ДЛЯ ПРОДВИЖЕНИЯ БИЗНЕСА В СТОМАТОЛОГИИ.....	485
Гусев А.В., АЛГОРИТМЫ ИНДЕКСИРОВАНИЯ ГЕОПРОСТРАНСТВЕННЫХ ДАННЫХ В СИСТЕМАХ КОНТРОЛЯ ЗА МОБИЛЬНЫМИ СРЕДСТВАМИ	489
Джаксымуратов К., Ембергенов Н., Айтмуратов А., ИССЛЕДОВАНИЯ КЛИМАТО - МЕЛИОРАТИВНЫХ УСЛОВИИ ПРИАРАЛЬЯ.....	493
Джаксымуратов К., Отеулиев М., Айтмуратов А., Бекмуратов А., ИССЛЕДОВАНИЕ РЕЖИМА, РЕСУРСОВ И ИСПОЛЬЗОВАНИЕ ПОДЗЕМНЫХ ВОД ЮЖНОГО ПРИАРАЛЬЯ (РЕСПУБЛИКА КАРАКАЛПАКСТАН)	497

Дружинина А.А., Ермаков Б.А., СОВРЕМЕННЫЕ МЕТОДЫ И ТЕХНОЛОГИИ ПРОДВИЖЕНИЯ ТУРИСТИЧЕСКИХ УСЛУГ В ИНТЕРНЕТ-ПРОСТРАНСТВЕ	502
Дустярова С.Н., ПОНЯТИЕ “ДУХОВНОСТЬ” В СЛОВАРЯХ И В СОВРЕМЕННОЙ НАУЧНОЙ ЛИТЕРАТУРЕ	505
Дышкекова В.Ф., Дадашев А.А., БИОЛОГИЯ В КОНТЕКСТЕ ФИЛОСОФИИ И МЕТОДОЛОГИИ НАУКИ XX ВЕКА	514_Точ63272648
Евстифеева У.С., Наконечная Т.В., АНАЛИЗ И ОПТИМИЗАЦИЯ ДЕНЕЖНЫХ ПОТОКОВ ОРГАНИЗАЦИИ	520
Ермоленко А.Л., Ляшенко В.В., О ПРЕДОРКЕСТРОВОМ ПЕРИОДЕ ОТЕЧЕСТВЕННОЙ ДУХОВОЙ МУЗЫКИ	524
Есинова Э.Б., ГОСУДАРСТВЕННЫЙ КОНТРОЛЬ И НАДЗОР В СИСТЕМЕ ГОСУДАРСТВЕННОГО УПРАВЛЕНИЯ НА ПРИМЕРЕ ФЕДЕРАЛЬНОЙ СЛУЖБЫ ПО НАДЗОРУ В СФЕРЕ ЗДРАВООХРАНЕНИЯ ПО РЕСПУБЛИКЕ КАЛМЫКИЯ	528
Ешимбетов У., Наурузбаева Г., Дальжанов К., МЕТОДИЧЕСКИЕ ВОПРОСЫ АНАЛИЗА И ПРОГНОЗИРОВАНИЯ ИНДУСТРИАЛЬНОГО РАЗВИТИЯ РЕГИОНА С УЧЕТОМ РАЦИОНАЛЬНОГО ИСПОЛЬЗОВАНИЯ МИНЕРАЛЬНЫХ РЕСУРСОВ.....	532
Жабборова С.Т., ПРОБЛЕМА ПОВЫШЕНИЯ ИНТЕРЕСА СТУДЕНТОВ К РУССКОМУ ЯЗЫКУ В ВУЗЕ	541
Жалолов Ш.У., РАЗЛИЧНЫЕ ПОДХОДЫ К КОНТРОЛЮ И ОЦЕНКЕ УЧЕБНОЙ ДЕЯТЕЛЬНОСТИ СТУДЕНТОВ	545
Жамолов А.Т., Хакбердийев Х.М., Набийев Т.У., Туляев Ф.М., ИНЖЕНЕРНО-ГЕОЛОГИЧЕСКАЯ КЛАССИФИКАЦИЯ БУРОВЫЕ РАСТВОРЫ ДЛЯ БУРЕНИЯ	549
Зульбухарова А.А., Каландаров М.М., ВЫРАЩИВАНИЕ ПЛОСКОВЕТОЧНИКА ВОСТОЧНОГО В БОТАНИЧЕСКОМ САДУ Г.ТАШКЕНТА	561
Ибрагимов И.У., ОРГАНИЗАЦИОННО-ЭКОНОМИЧЕСКИЙ МЕХАНИЗМ УПРАВЛЕНИЯ МАЛЫМ БИЗНЕСОМ.....	566
Ибрагимов И.У., РАЗВИТИЕ ИСПОЛЬЗОВАНИЯ КЛАСТЕРНОЙ СИСТЕМЫ В ЭФФЕКТИВНОМ УПРАВЛЕНИИ ХОЗЯЙСТВЕННЫМИ ОБЩЕСТВАМИ	570
Ибрагимова Ш., Исмоилова З., ФОРМИРОВАНИЕ МЕТОДИЧЕСКОЙ КОМПЕТЕНТНОСТИ БУДУЩИХ УЧИТЕЛЕЙ НАЧАЛЬНОЙ ШКОЛЫ	574

Игнатенко Е.В., Игнатенко П.В., Губкина Л.А., Губкин А.В., ПРОЕКТИРОВАНИЕ ЭКСПЕРТНОЙ СИСТЕМЫ ПОДБОРА ОДЕЖДЫ С ПОМОЩЬЮ ОБОЛОЧКИ-ИНТЕРПРЕТАТОРА БАЗ ЗНАНИЙ ESWIN	579
Ихнев В.С., АНАЛИЗ ФИНАНСОВО-ЭКОНОМИЧЕСКИХ ИТОГОВ И ПРОБЛЕМ РЕАЛИЗАЦИИ ГОСУДАРСТВЕННЫХ ПРОГРАММ В СФЕРЕ КУЛЬТУРЫ СУБЪЕКТОВ РФ	584
Камилова Р.Ш., Кузнецова М.А., ПРОГРАММНЫЙ КОМПЛЕКС «1С: ПРЕДПРИЯТИЕ». СРАВНИТЕЛЬНЫЙ АНАЛИЗ, ДОСТОИНСТВА И НЕДОСТАТКИ	594
Камилова Р.Ш., Магомедов А.Г., СОВЕРШЕНСТВОВАНИЕ СИСТЕМЫ НАЛОГОВОГО УЧЁТА	598
Камилова Р.Ш., Кузнецова М.А., ПРОГРАММНЫЙ КОМПЛЕКС «ПАРУС» и «ИНФИН-БУХГАЛТЕРИЯ». СРАВНИТЕЛЬНЫЙ АНАЛИЗ, ДОСТОИНСТВА И НЕДОСТАТКИ	602
Камилова Р.Ш., Магомедов А.Г., ОРГАНИЗАЦИЯ НАЛОГОВОГО УЧЁТА НА ПРЕДПРИЯТИИ	606
Каримов Н., Каримова З., ФИЛОСОФИЯ РАННЕГО СРЕДНЕВЕКОВЬЯ	609
Қаххаров М.М., Мўминжонов М.М., ТЕОРИЯ ПЕРКОЛЯЦИИ И КЛАСТЕРЫ	618
Қаххаров С.С., Баҳромов Б.М., ПОЛИМЕРНЫЕ КОНСТРУКЦИИ КОМПОЗИТНЫХ МАТЕРИАЛОВ	623
Қодиров Р.Ш., Мамазулунов Н.Х., Ботиров Э.Х., Юсупов М.М., ФЛАВОНОИДЫ RUSSOWIA SOGDIANA (BGE). FEDSCH	628
Комилова З.Х., Назиржонова Ф.С., МЕТОДЫ ЗАЩИТЫ КОМПЬЮТЕРНОЙ СЕТИ ОТ НЕСАНКЦИОНИРОВАННОГО ДОСТУПА ИЗ СЕТИ ИНТЕРНЕТ	632
Комов Д.А., Таланов А.Д., Кузнецов А.К., Никулин А.С., ИНФОРМАЦИОННОЕ ОБЕСПЕЧЕНИЕ И ЕДИНОЕ ИНФОРМАЦИОННОЕ ПРОСТРАНСТВО В СФЕРЕ ГОСУДАРСТВЕННОГО И МУНИЦИПАЛЬНОГО УПРАВЛЕНИЯ	635
Конькова О.В., ТЕНДЕНЦИИ СОЦИАЛЬНО-ЭКОНОМИЧЕСКОГО РОСТА РАЗВИТИЯ СТРАНЫ	643
Конькова О.В., ИНТЕГРИРОВАННЫЙ ПОДХОД И МОДЕЛИРОВАНИЕ ФАЗ ЦИКЛИЧЕСКИХ ПРОЦЕССОВ В СЕЛЬСКОМ ХОЗЯЙСТВЕ РОССИИ	648

Коротченкова А.В., Алексеева И.В., ИСПОЛЬЗОВАНИЕ ИНСТРУМЕНТОВ ЦИФРОВОЙ ЭКОНОМИКИ ДЛЯ ФОРМИРОВАНИЯ ФИНАНСОВОЙ ОТЧЕТНОСТИ КОММЕРЧЕСКИХ ОРГАНИЗАЦИЙ.	653
Кочанова А.А., КРІ КАК СОВРЕМЕННЫЙ ИНСТРУМЕНТ МОТИВАЦИИ ПЕРСОНАЛА ПРЕДПРИЯТИЯ	658
Кочанова А.А., СОВРЕМЕННАЯ ПРАКТИКА МОТИВАЦИИ ПЕРСОНАЛА.....	663
Кочко Н.А., Семенникова В.В., Кувалдин В.Д., ОТВЕТСТВЕННОСТЬ ОРГАНОВ МЕСТНОГО САМОУПРАВЛЕНИЯ ПЕРЕД ФИЗИЧЕСКИМИ И ЮРИДИЧЕСКИМИ ЛИЦАМИ.....	667
Кузеванов Е.Е., МЕТОДИЧЕСКИЕ РЕКОМЕНДАЦИИ ПО РАЗРАБОТКЕ ПЛАНИРУЕМЫХ РЕЗУЛЬТАТОВ ОСВОЕНИЯ РАБОЧЕЙ ПРОГРАММЫ «ФИЗИЧЕСКАЯ КУЛЬТУРА».....	673
Кулакова О.А., К ВОПРОСУ О ПРАВЕ ПОДПИСИ ПРИ ВЕДЕНИИ БУХГАЛТЕРСКОГО УЧЕТА КОНСАЛТИНГОВОЙ ФИРМОЙ.....	677
Кулакова О.А., АНАЛИЗ СОВРЕМЕННЫХ ПРОБЛЕМ НА РЫНКЕ ЮВЕЛИРНОЙ ОТРАСЛИ	681
Куликов И.А., ОБЗОР НОРМАТИВНОГО РЕГУЛИРОВАНИЯ БУХГАЛТЕРСКОГО УЧЁТА РАСХОДОВ В СОВРЕМЕННЫХ ЭКОНОМИЧЕСКИХ УСЛОВИЯХ	686
Куликов И.А., МЕТОДИКА АНАЛИЗА КРЕДИТОРСКОЙ ЗАДОЛЖЕННОСТИ ОРГАНИЗАЦИИ	691
Лагода М.Ю., АНАЛИЗ ЭФФЕКТИВНОСТИ ИСПОЛЬЗОВАНИЯ МАТЕРИАЛЬНЫХ РЕСУРСОВ.....	696
Лепс Я.С., Романова Л.М., СОВЕРШЕНСТВОВАНИЕ ТЕХНОЛОГИЙ В ЭКСКУРСИОННОЙ ДЕЯТЕЛЬНОСТИ.....	702
Ли А.А., АНАЛИЗ РОЗНИЧНОГО ТОВАРООБОРОТА ТОРГОВОЙ ОРГАНИЗАЦИИ НА ПРИМЕРЕ ООО «АЛЕКСАНДРИТ»	706
Ли Саша, СПОРТИВНЫЙ МАРКЕТИНГ В УСЛОВИЯХ ПАНДЕМИИ COVID-19	715
Литвина С.О., СОВЕРШЕНСТВОВАНИЕ МЕТОДИКИ ОПРЕДЕЛЕНИЯ СТАВКИ ДИСКОНТИРОВАНИЯ ДЛЯ ОЦЕНКИ СТОИМОСТИ ПРЕДПРИЯТИЙ ДОХОДНЫМ ПОДХОДОМ	718
Лихолетова Н.В., СОВЕРШЕНСТВОВАНИЕ СОСТАВЛЕНИЯ ОТЧЕТА ДВИЖЕНИЯ ДЕНЕЖНЫХ СРЕДСТВ В СЕЛЬСКОХОЗЯЙСТВЕННОМ ПРЕДПРИЯТИИ.....	725

Лукьяненко П.А., ПРАВОВОЕ РЕГУЛИРОВАНИЕ ВЗАИМОДЕЙСТВИЯ ОРГАНОВ ВЛАСТИ СУБЪЕКТА РОССИЙСКОЙ ФЕДЕРАЦИИ И ОРГАНОВ МЕСТНОГО САМОУПРАВЛЕНИЯ.....	730
Лусакуено Ж.К., СВЯЗИ С ОБЩЕСТВЕННОСТЬЮ В ГОСУДАРСТВЕННОМ УПРАВЛЕНИИ	738
Ляшенко В.В., Кавторев В.В., К ВОПРОСУ О РЕФОРМЕ РУССКОЙ ВОЕННОЙ МУЗЫКИ ВО ВТОРОЙ ПОЛОВИНЕ 19 ВЕКА	742
Мадиханова Б.М., ТЕОРЕТИЧЕСКИЙ АСПЕКТ ТЕХНОЛОГИЙ ОБУЧЕНИЯ РУССКОМУ ЯЗЫКУ КАК ВТОРОМУ	745
Майструк В.А., Дудин Н.В., МОДЕРНИЗАЦИЯ ТЕХНОЛОГИЧЕСКИХ РЕЖИМОВ НЕФТЕГАЗОВОГО КОМПЛЕКСА ЗАПАДНОЙ СИБИРИ.	749
Малышева Д.Е., МЕСТО ИНСТРУМЕНТОВ ПРОГРАММНО-ЦЕЛЕВОГО БЮДЖЕТИРОВАНИЯ В МЕХАНИЗМЕ РЕАЛИЗАЦИИ МЕЖБЮДЖЕТНЫХ ОТНОШЕНИЙ В СУБЪЕКТЕ РОССИЙСКОЙ ФЕДЕРАЦИИ	757
Мамажонова З.К., Хужамбердиев М.А., Кодирова Г.И., Юлдашева С.Л., ОЦЕНКА КАЧЕСТВА МЕДИЦИНСКОЙ ПОМОЩИ ПРИ АРТЕРИАЛЬНОЙ ГИПЕРТОНИИ СРЕДИ СОТРУДНИКОВ UZ-AVTO MOTORSB АНДИЖАНСКОЙ ОБЛАСТИ.....	763
Мамонтова В.М., Кувалдин В.Д., Улмасов М.А., КУЛЬТУРА МУНИЦИПАЛЬНОГО ПРАВА.....	767
Маруфова З., ШАРҚОНА ҒЎЗАЛЛИК ТАСВИРИДА ЎСИМЛИК НОМЛАРИНИНГ РОЛИ	773
Махмудов Б.М., Холбоев Д.Ж., ГЕЛИО КОЛЛЕКТОРНЫЕ УСТРОЙСТВА И ГРУППИРОВКА.....	777
Махмудов О.Т., ЗАРУБЕЖНЫЙ ОПЫТ ОПРЕДЕЛЕНИЯ РЕЙТИНГА КОММЕРЧЕСКИХ БАНКОВ	781
Махмудов В.В., Ходжанов А.Р., СОЦИАЛЬНЫЕ ФУНКЦИИ ФИЗИЧЕСКОЙ КУЛЬТУРЫ И СПОРТА	787
Мелентьева О.А., УПРАВЛЕНИЕ КАЧЕСТВОМ ПРОДУКЦИИ НА ПРЕДПРИЯТИЯХ ПИЩЕВОЙ ПРОМЫШЛЕННОСТИ	791
Миловидова В.С., УПРАВЛЕНИЕ РИСКАМИ В СИСТЕМЕ ЗДРАВООХРАНЕНИЯ.....	794
Михайлов В.С., ОСОБЕННОСТИ ОЦЕНКИ ИНВЕСТИЦИОННЫХ ПРОЕКТОВ ОБНОВЛЕНИЯ ТЕХНОЛОГИИ ПЕРЕРАБОТКИ САХАРНОЙ СВЁКЛЫ	798
Мицкевич Н.О., ДИНАМИКА СТАВКИ РЕФИНАНСИРОВАНИЯ В РЕСПУБЛИКЕ БЕЛАРУСЬ	807

Морозов М.К., СОВРЕМЕННЫЕ ТЕНДЕНЦИИ ПРЯМЫХ ИНОСТРАННЫХ ИНВЕСТИЦИЙ В МИРЕ	811
Муминова Н.М., СПОСОБЫ АКТИВИЗАЦИИ ДЕЯТЕЛЬНОСТИ НА УРОКАХ РУССКОГО ЯЗЫКА.....	818
Мурадов А.А., АНАЛИЗ МЕХАНИЗМА ЗАКЛЮЧАЮЩИХ ПЛАТИН ВЯЗАЛЬНО-ПРОШИВНЫХ МАШИН	822
Мякотина А.С., Заяшникова И.А., АКТУАЛЬНЫЕ ВОПРОСЫ УПРАВЛЕНИЯ ИМУЩЕСТВОМ МУНИЦИПАЛЬНОГО ОБРАЗОВАНИЯ.....	827
Набиев М.Я., Содиқов Т.Б., СОЛНЕЧНАЯ СУШКА ХЛОПКА.....	835
Насритдинов К.М., Уролов С.Г., СЕЛЬСКОЕ ХОЗЯЙСТВО УЗБЕКИСТАНА ВО ВРЕМЯ ВТОРОЙ МИРОВОЙ ВОЙНЫ.....	839
Недригайлова А.П., СОЦИАЛЬНАЯ СФЕРА.....	844
Ниязметова Н.Б., СОВЕРШЕНСТВОВАНИЕ МЕТОДИКИ ОБУЧЕНИЯ СТУДЕНТОВ ТЕХНОЛОГИИ НА ОСНОВЕ ИНТЕГРИРОВАННОГО ОБУЧЕНИЯ.....	847
Ноибжонова Х.М., БИОХИМИЧЕСКИЕ СВОЙСТВА ЖЕЛЕЗЫ.....	855
Ноибжонова Х.М., СВОЙСТВА ВИТАМИНОВ	857
Норқобилов М.Н., ФИЗИЧЕСКАЯ КУЛЬТУРА И ЗНАНИЯ СТУДЕНТОВ	859
Огнев П.Н., Доржиева А.Б., МУНИЦИПАЛЬНО-ПРАВОВАЯ ОТВЕТСТВЕННОСТЬ.....	863
Орипова Н., Нарзиева Л., СОЦИАЛЬНО-ИСТОРИЧЕСКИЕ И ПЕДАГОГИЧЕСКИЕ ПРОБЛЕМЫ ОВЛАДЕНИЯ ПРОФЕССИЕЙ	868
Османов Р.Т., МЕТОДЫ СОЦИАЛЬНО-ЭКОНОМИЧЕСКОГО РАЗВИТИЯ СЕЛЬСКИХ ТЕРРИТОРИЙ	872
Отабоева З.Ғ., Абдумухтарова Б., БОШҚАРУВ ТИЗИМИДА НИЗОЛИ ВАЗИЯТЛАР ПСИХОЛОГИЯСИ	877

ЭЛЕКТРОННОЕ НАУЧНО-ПРАКТИЧЕСКОЕ
ПЕРИОДИЧЕСКОЕ МЕЖДУНАРОДНОЕ ИЗДАНИЕ

«Экономика и социум»

Выпуск № 12(79) 2020

Сайт: <http://www.iupr.ru>

Издательство: ООО "Институт управления и социально-
экономического развития", Россия, г. Саратов

Дата издания: Декабрь 2020