

PAPER • OPEN ACCESS

Vibrations of high-rise buildings under seismic impact taking into account physical nonlinearity

To cite this article: S Mirzaev *et al* 2022 *J. Phys.: Conf. Ser.* **2176** 012052

View the [article online](#) for updates and enhancements.

You may also like

- [On improving productivity of a combined cotton picker](#)

R D Matchanov and A I Yuldashev

- [Propagation of fungi in the soils: A case study of scientific experimental fields of forestry of Tashkent region](#)

S Yu Khidirov, R Gulmurodov, M S Mamiev *et al.*

- [Combined cotton picker with interchangeable devices](#)

R Matchanov, A Rizayev, K Astanakulov *et al.*



ECS Membership = Connection

ECS membership connects you to the electrochemical community:

- Facilitate your research and discovery through ECS meetings which convene scientists from around the world;
- Access professional support through your lifetime career;
- Open up mentorship opportunities across the stages of your career;
- Build relationships that nurture partnership, teamwork—and success!

Join ECS!

Visit electrochem.org/join



Vibrations of high-rise buildings under seismic impact taking into account physical nonlinearity

S Mirzaev¹, M Yusupov², B Rakhmankulova¹, G Abdikayimova³

¹ Tashkent Institute of Irrigation and Agricultural Mechanization Engineers, 39, Kari Niyazi street, Tashkent, 100 000, Uzbekistan

² Tashkent Regional Chirchik State Pedagogical Institute, 104, Amir Temur avenue, Chirchik city, Tashkent region, 111700, Uzbekistan

³ Tashkent Technical University named after Islam Karimov, 2, University street, Tashkent, 100095, Uzbekistan

E-mail: smirzaev@yandex.ru

Abstract. Analytical description of vibration loads of the complex construction structure is considered as a system of masses connected by means of viscoelastic springs. To take into account the rheological properties of the spring material, the Boltzmann-Volterra principle is used. A mathematical model of the problem under consideration has been developed, which boils down to the solution of a system of nonlinear integro-differential equations. A solution method based on the use of quadrature formulas has been developed and a computer program has been compiled on its basis. The results are shown as graphs. Influence of nonlinear and rheological properties of spring on amplitude and phase of mass oscillations is investigated.

1. Introduction

Tower and mast-type high-rise structures are exposed to variable loads during operation: these are loads caused by equipment operation, wind load, seismic disturbances.

The idea of vibration isolation was realized in the Middle Ages. So, during the construction of Central Asian minarets, special "reed belts" or pillows made of bulk material were laid in the foundations. However, the theory of vibration isolation has been developed only in the last 25-30 years. The first works in this area were aimed at reducing inertial seismic loads by reducing the period of the fundamental pitch of the structure's oscillations [1].

Calculation of buildings and structures designed for seismic areas is carried out according to SNiP methodology based on linear-spectral approach. This method of calculation does not allow one to estimate probabilities of deviation of calculated values of reaction from actual values, as well as to reveal reserves of strength of structures associated with physically nonlinear properties of structural materials, which appear during dynamic loading [2].

Currently, there are a large number of design varieties of vibration protection devices designed both for the protection of devices and equipment installed on vibrating bases, and for the protection of bases and foundations from dynamic effects.

Since the damping forces for the actual construction of an industrial building cannot be estimated with the same accuracy as the elastic and inertia forces, strict mathematical modeling of damping phenomena is impossible. However, in order to explain the dissipative forces present in any design, it



is necessary to assume the form of damping, which makes it possible to evaluate the damping forces in practice. In addition, the type of damping should contribute to simple mathematical operations specifically applied to linear equations of motion - this means that during harmonic excitation, the damping forces also change according to a harmonic law. Two such suitable forms of damping are viscous and hysteresis damping. In any vibration protection system there are both forms of damping, but in different ratios [3].

2. Statement and mathematical model of the problem

For the analytical description of vibration loads, a complex construction structure can be considered as a system of masses connected using viscoelastic elements. We consider the vertical vibrations of four weights (Figure 1) with masses m_1 , m_2 , m_3 and m_4 connected by nonlinear viscoelastic elements. We denote the displacements of weights with masses m_1 , m_2 , m_3 and m_4 from the static equilibrium position through x_1 , x_2 , x_3 and x_4 , and the force of action of elements on mass – through $F(z)$.

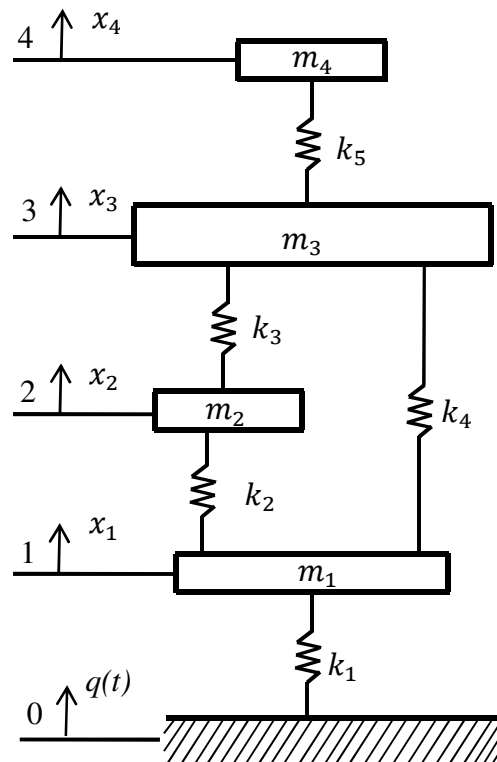

Figure 1. Diagram of the vibration protection system of the construction structure.

Using the D'alambert principle and considering the fictitious equilibrium of masses to which inertia forces and restoring forces are applied, we obtain [4.5]:

$$\begin{cases} m_1 \ddot{x}_1 + F(x_1) - F(x_2 - x_1) - F(x_3 - x_1) = q \\ m_2 \ddot{x}_2 + F(x_2 - x_1) - F(x_3 - x_2) = 0 \\ m_3 \ddot{x}_3 + F(x_3 - x_1) + F_3(x_3 - x_2) - F(x_4 - x_3) = 0 \\ m_4 \ddot{x}_4 + F(x_4 - x_3) = 0. \end{cases} \quad (1)$$

For the function $F(z)$, we accept the expression [6-8]:

$$F(z) = k(1 - R^*)z(1 + \gamma z^2) \quad (2)$$

where k is a stiffness factor of viscoelastic links (elements); γ is a coefficient of nonlinearity depending on physical properties of element material; R^* is an integral operator with relaxation nucleus $R(t, \tau) = \varepsilon e^{-\beta(t-\tau)} \cdot (t - \tau)^{\alpha-1}$:

$$R^*z = \int_0^t R(t, \tau)z(\tau)d\tau.$$

Then taking into account (2) the system (1) will have the form:

$$\left\{ \begin{array}{l} m_1 \ddot{x}_1 + k_1(1 - R_1^*)x_1(1 + \gamma_1 x_1^2) - k_2(1 - R_2^*)(x_2 - x_1)[1 + \gamma_2(x_2 - x_1)^2] - \\ \quad - k_4(1 - R_4^*)(x_3 - x_1)[1 + \gamma_4(x_3 - x_1)^2] = q_1; \\ m_2 \ddot{x}_2 + k_2(1 - R_2^*)(x_2 - x_1)[1 + \gamma_2(x_2 - x_1)^2] - k_3(1 - R_3^*)(x_3 - x_2)[1 + \gamma_3(x_3 - x_2)^2] = 0; \\ m_3 \ddot{x}_3 + k_4(1 - R_4^*)(x_3 - x_1)[1 + \gamma_4(x_3 - x_1)^2] - k_3(1 - R_3^*)(x_3 - x_2)[1 + \gamma_3(x_3 - x_2)^2] - \\ \quad - k_5(1 - R_5^*)(x_4 - x_3)[1 + \gamma_5(x_4 - x_3)^2] = 0; \\ m_4 \ddot{x}_4 + k_5(1 - R_5^*)(x_4 - x_3)[1 + \gamma_5(x_4 - x_3)^2] = 0. \end{array} \right.$$

We accept that $x_1(0) = \dot{x}_1(0) = x_2(0) = \dot{x}_2(0) = x_3(0) = \dot{x}_3(0) = x_4(0) = \dot{x}_4(0) = 0$.

3. Solution methods

By entering dimensionless parameters:

$$\frac{t}{\tau}; \frac{R_i}{\tau}; \frac{x_1}{l}; \frac{x_2}{l}; \frac{x_3}{l}; \frac{x_4}{l}; \frac{q_1}{q_0}; \frac{\gamma_i}{l^2}$$

and while retaining the former designations, we have:

$$\left\{ \begin{array}{l} \ddot{x}_1 + c_1(1 - R_1^*)x_1(1 + \gamma_1 x_1^2) - c_2(1 - R_2^*)(x_2 - x_1)[1 + \gamma_2(x_2 - x_1)^2] - \\ \quad - c_3(1 - R_4^*)(x_3 - x_1)[1 + \gamma_4(x_3 - x_1)^2] = q_1; \\ \ddot{x}_2 + c_4(1 - R_2^*)(x_2 - x_1)[1 + \gamma_2(x_2 - x_1)^2] - c_5(1 - R_3^*)(x_3 - x_2)[1 + \gamma_3(x_3 - x_2)^2] = 0; \\ \ddot{x}_3 + c_6(1 - R_4^*)(x_3 - x_1)[1 + \gamma_4(x_3 - x_1)^2] - c_7(1 - R_3^*)(x_3 - x_2)[1 + \gamma_3(x_3 - x_2)^2] - \\ \quad - c_8(1 - R_5^*)(x_4 - x_3)[1 + \gamma_5(x_4 - x_3)^2] = 0; \\ \ddot{x}_4 + c_9(1 - R_5^*)(x_4 - x_3)[1 + \gamma_5(x_4 - x_3)^2] = 0. \end{array} \right. \quad (3)$$

here

$$c_1 = \frac{k_1 \tau^2}{m_1}; \quad c_2 = \frac{k_2 \tau^2}{m_1}; \quad c_3 = \frac{k_4 \tau^2}{m_1}; \quad c_4 = \frac{k_2 \tau^2}{m_2}; \quad c_5 = \frac{k_3 \tau^2}{m_2}; \quad c_6 = \frac{k_4 \tau^2}{m_3}; \\ c_7 = \frac{k_3 \tau^2}{m_3}; \quad c_8 = \frac{k_5 \tau^2}{m_3}; \quad c_9 = \frac{k_5 \tau^2}{m_4}; \quad q = \frac{\tau^2}{m_1 l} \cdot q_1.$$

The system (3) is solved by methods based on the quadrature formula [7-13]. Integrating the system (3) twice by t , at the interval $[0; t]$ we have:

$$\begin{aligned}
x_1(t) &= -c_1 \int_0^t G_1(t-s)x_1(s)[1 + \gamma_1 x_1^2(s)]ds + \\
&+ c_2 \int_0^t G_2(t-s)[x_2(s) - x_1(s)]\{1 + \gamma_2[x_2(s) - x_1(s)]^2\}ds + \\
&+ c_3 \int_0^t G_4(t-s)[x_3(s) - x_1(s)]\{1 + \gamma_4[x_3(s) - x_1(s)]^2\}ds + \int_0^t (t-s)q_1(s)ds; \\
x_2(t) &= -c_4 \int_0^t G_2(t-s)[x_2(s) - x_1(s)]\{1 + \gamma_2[x_2(s) - x_1(s)]^2\}ds + \\
&+ c_5 \int_0^t G_3(t-s)[x_3(s) - x_2(s)]\{1 + \gamma_3[x_3(s) - x_2(s)]^2\}ds; \\
x_3(t) &= -c_6 \int_0^t G_4(t-s)[x_3(s) - x_1(s)]\{1 + \gamma_4[x_3(s) - x_1(s)]^2\}ds + \\
&+ c_7 \int_0^t G_3(t-s)[x_3(s) - x_2(s)]\{1 + \gamma_3[x_3(s) - x_2(s)]^2\}ds + \\
&+ c_8 \int_0^t G_5(t-s)[x_4(s) - x_3(s)]\{1 + \gamma_5[x_4(s) - x_3(s)]^2\}ds; \\
x_4(t) &= -c_9 \int_0^t G_5(t-s)[x_4(s) - x_3(s)]\{1 + \gamma_5[x_4(s) - x_3(s)]^2\}ds;
\end{aligned}$$

where

$$G_i(t-s) = t-s - \int_0^{t-s} (t-s-\tau)R_i(\tau)d\tau, \quad R_i(t) = \varepsilon_i e^{-\beta_i t} \cdot t^{\alpha_i-1}, \quad (i = \overline{1,5}).$$

In the latter system, replacing the integrals with quadrature trapezoid formulas to determine the displacement of the load from the static equilibrium position $x_{1i} = x_1(t_i)$, $x_{2i} = x_2(t_i)$, $x_{3i} = x_3(t_i)$ and $x_{4i} = x_4(t_i)$ ($i = 1, 2, 3, \dots$), we have the following recurrence expressions:

$$\begin{aligned}
x_{1n} &= -c_1 \sum_{i=0}^{n-1} A_i G_1(t_n - t_i) x_{1i} [1 + \gamma_1 x_{1i}^2] + \\
&+ c_2 \sum_{i=0}^{n-1} A_i G_2(t_n - t_i) [x_{2i} - x_{1i}] \{1 + \gamma_2 [x_{2i} - x_{1i}]^2\} +
\end{aligned}$$

$$\begin{aligned}
& +c_3 \sum_{i=0}^{n-1} A_i G_4(t_n - t_i) [x_{3i}(s) - x_{1i}(s)] \{1 + \gamma_4 [x_{3i}(s) - x_{1i}(s)]^2\} + \sum_{i=0}^{n-1} A_i (t_n - t_i) q_1(t_i); \\
x_{2n} = & -c_4 \sum_{i=0}^{n-1} A_i G_2(t_n - t_i) [x_{2i}(s) - x_{1i}(s)] \{1 + \gamma_2 [x_{2i}(s) - x_{1i}(s)]^2\} + \\
& +c_5 \sum_{i=0}^{n-1} A_i G_3(t_n - t_i) [x_{3i}(s) - x_{2i}(s)] \{1 + \gamma_3 [x_{3i}(s) - x_{2i}(s)]^2\}; \quad (4) \\
x_{3n} = & -c_6 \sum_{i=0}^{n-1} A_i G_4(t_n - t_i) [x_{3i}(s) - x_{1i}(s)] \{1 + \gamma_4 [x_{3i}(s) - x_{1i}(s)]^2\} + \\
& +c_7 \sum_{i=0}^{n-1} A_i G_3(t_n - t_i) [x_{3i}(s) - x_{2i}(s)] \{1 + \gamma_3 [x_{3i}(s) - x_{2i}(s)]^2\} + \\
& +c_8 \sum_{i=0}^{n-1} A_i G_5(t_n - t_i) [x_{4i}(s) - x_{3i}(s)] \{1 + \gamma_5 [x_{4i}(s) - x_{3i}(s)]^2\}; \\
x_{4n} = & -c_9 \sum_{i=0}^{n-1} A_i G_5(t_n - t_i) [x_{4i}(s) - x_{3i}(s)] \{1 + \gamma_5 [x_{4i}(s) - x_{3i}(s)]^2\};
\end{aligned}$$

where $t_i = i \cdot \Delta t$; $i = \overline{0, n}$; $A_0 = A_n = \frac{\Delta t}{2}$; $A_j = \Delta t$, $j = \overline{1, n-1}$.

4. Results and conclusions

To conduct a computational experiment, a computer program has been developed that implements the proposed algorithm. The results are shown as graphs. The calculation uses the following initial data: $c_1 = 2,84$; $c_2 = 2,84$; $c_3 = 2,71$; $c_4 = 2,75$; $c_5 = 1,32$; $c_6 = 2,30$; $c_7 = 1,15$; $c_8 = 2,76$; $c_9 = 4,41$; $\gamma_1 = 15$; $\gamma_2 = 20$; $\gamma_3 = 16$; $\gamma_4 = 17$; $\gamma_5 = 19$; $\alpha_i = 0,25$; $\beta_i = 0,05$; $\varepsilon_i = 0,01$ ($i = \overline{1,5}$); $q(t) = 1,2e^{-0,7t} \sin 2,1\pi t$.

Figures 2,3,4,5 show non-linear elastic (solid line) and viscoelastic (dashed line) vibrations of weights with masses m_1 , m_2 , m_3 and m_4 from static equilibrium position. It can be seen from the graph that considering the rheological properties of the element leads to a decrease in the amplitude of the weights from the static equilibrium position. Reduced frequency of weights oscillation results in phase shift. Over time, the viscoelastic properties of the element significantly affect the amplitudes and frequencies of the weights.

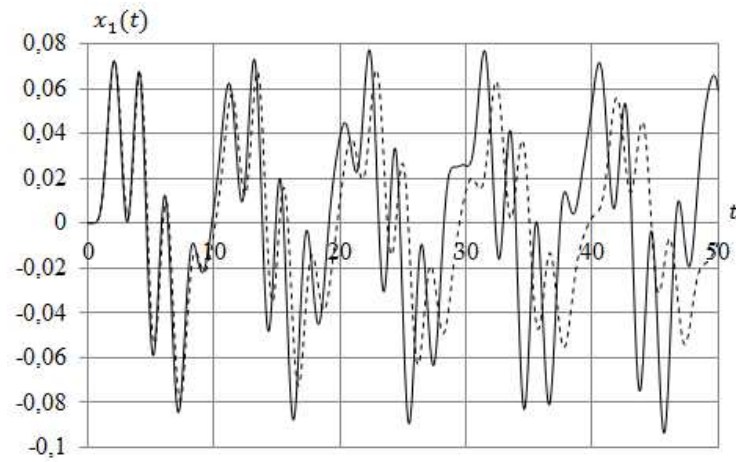

Figure 2. Shape of load oscillations with mass m_1 .

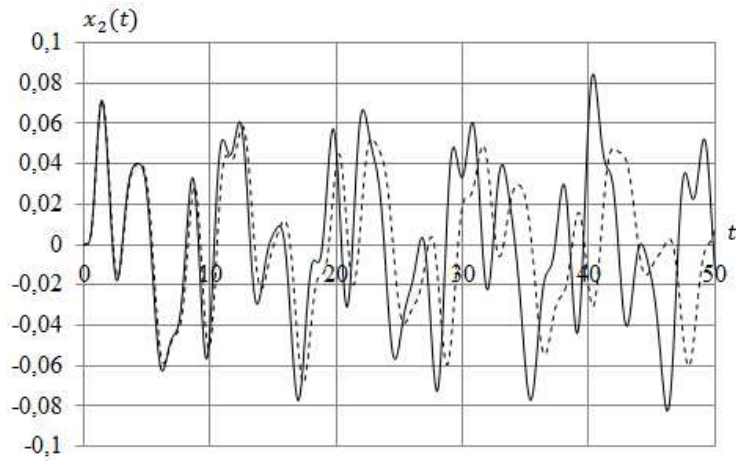

Figure 3. Shape of load oscillations with mass m_2 .

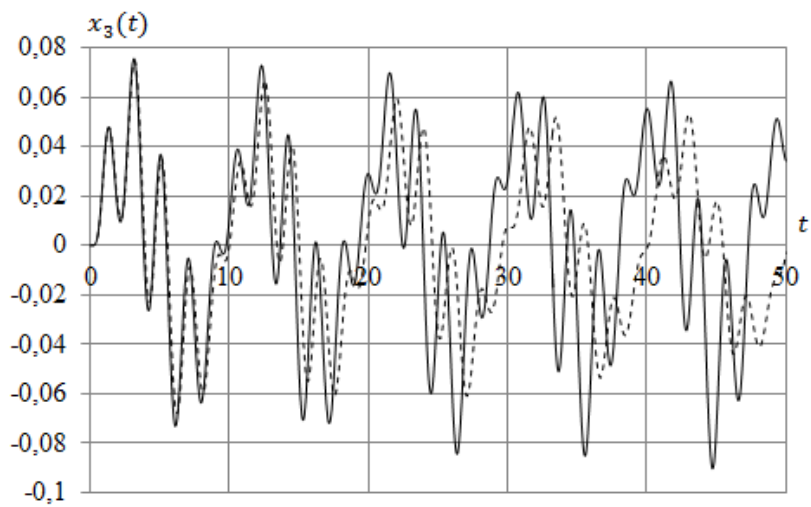

Figure 4. Shape of load oscillations with mass m_3 .

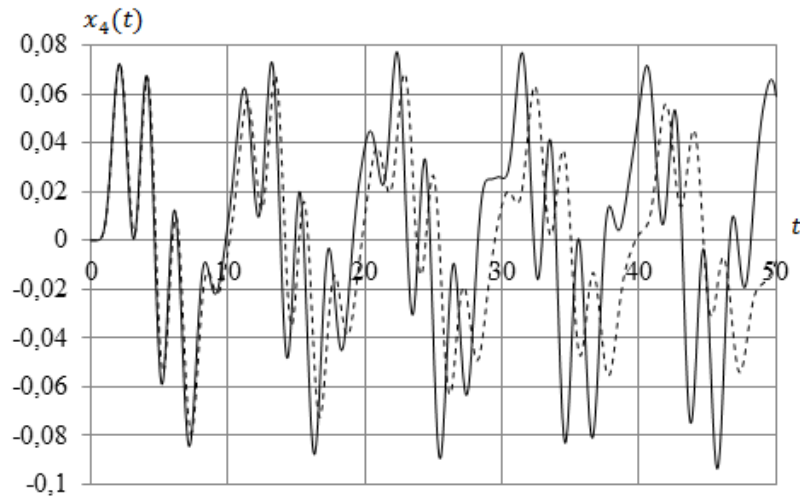

Figure 5. Shape of load oscillations with mass m_4 .

There is a large class of problems of the dynamics of structures in which systems cannot be considered elastic. For example, the reaction of buildings in an earthquake can be quite intense, which leads to serious damage to structures. Stiffness factors can vary due to the appearance of fluidity in structural elements. In many cases, it is necessary to attract a nonlinear theory of viscoelasticity. In this case, the equilibrium equation of structures will be written in the form of systems of nonlinear integro-differential equations. The use of schemes capable of obtaining a solution in a closed form or using algorithms of type (4) is of great interest. The obtained results allow us to conclude that it is advisable to apply the theory of hereditary viscosity-elasticity to reduce the amplitude of oscillations, both in ideally elastic and in hereditary-deformable systems during transient processes.

References

- [1] Uzdin A M 1993 *Fundamentals of the theory of seismic resistance and earthquake-resistant construction of buildings and structures*. (St. Petersburg, Russia VNI)
- [2] Birbraer A N 1998 *Calculation of structures for seismic resistance*. (St. Petersburg, Russia Science)
- [3] Gordeev B A, Filatov L V and Einbinder R M 2018 *Mathematical models of vibration protection systems* (Nizhny Novgorod, Russia NNGASU)
- [4] Bondar N G 1972 *Nonlinear autonomous systems of construction mechanics* (Moscow, Russia Stroyizdat)
- [5] Bondar N G 1967 *Applied Mathematics* **3(5)** 1-8
- [6] Ilyushin A A, Ogibalov P M 1962 *Polymer mechanics* **2** 170-189
- [7] Kauderer G 1961 *Nonlinear mechanics* (Moscow, Russia Mir)
- [8] Aldoshin G T 2013 *Theory of linear and nonlinear oscillations* (St. Petersburg, Russia LAN Publishing House)
- [9] Yusupov M, Rahkmankulova B and Aynaqulov Sh 2019 *E3S Web of Conferences* **97**, 05024
- [10] Abdullaev Z, Yusupov M, Mirzaev S, Noraliyev N and Kusharov Z 2020 *IOP Conference Series: Materials Science and Engineering* **896** 012116
- [11] Yusupov M, Rahkmankulova B, Ziyaeva Sh and Kushaev A 2020 *IOP Conference Series: Materials Science and Engineering* **896** 012141
- [12] Yusupov M, Akhmedov B A and Karpova O V 2020 *Acta of Turin Polytechnic University in Tashkent* **10** 71-75

- [13] Yusupov M, Pardaboev A, Kubyashev K and Mavlanov S 2019 *Int. Conf. on Information science and communications technologies: Applications, Trends and Opportunities*, ICISCT 2019. (Tashkent, Uzbekistan)