

Calculation of strength of stilling basins and pressure in downstream water outlet structures

Sanatjon Khidirov^{1*}, *Fotima Artikbekova*¹, *Ilkhom Begmatov*¹, *Azam Azimov*¹, *Naim Ismailov*¹, and *A. V. Sadikova*²

¹“Tashkent Institute of Irrigation and Agricultural Mechanization Engineers” National Research University, Tashkent, Uzbekistan

²Tashkent State Pedagogical University, Tashkent, Uzbekistan

Abstract. Calculations performed to determine the strength of the stilling basin and apron of the downstream zone should mainly be carried out, considering the conditions of their stability and strength. When calculating the elements of the fastening zone for strength and stability, it is advisable to consider vertical and moment hydrodynamic stresses. Conducting targeted research on developing scientific methods for calculating the interface between the spillway and downstream outlet structures, mitigating kinetic energy in the downstream toe, choosing designs for protecting downstream of the structure, and determining hydrodynamic loads is particularly important. In this regard, one of the important tasks is to conduct scientific research on improving the design of the downstream toe, working out methods for determining hydrodynamic loads while calculating the thickness of the stilling basin and apron, which ensures the strength of the downstream toe.

1 Introduction

The possibility of determining the stability of stilling basin and apron in the downstream water outlets of low- and medium-head reservoirs by comparing their vibrational oscillations with the spectral characteristics of pulsating stresses is substantiated by the authors of the article considering the results of experiments carried out by other researchers [1-7].

However, unfortunately, it was impossible to measure these structures' partial vibrations in actual operating and field conditions. Therefore, in these calculations, we restrict ourselves to statically setting stresses, not considering the dynamics of their foundations.

The unstable state of the downstream part of water structures is explained by the inconstancy of the hydraulic modes of operation. Structures often operate in the absence of flooding from the downstream side, which causes undesirable hydraulic phenomena, forms of conjunction - a repulsed jump or a hydraulic wave jump with an uneven distribution of velocities and significant pressure fluctuations, especially during the start-up period; design flaws and deviations from the design during anchoring and construction, taking into

*Corresponding author: sanat.kx@mail.ru

account difficult engineering and geological conditions; poor-quality construction work or unsatisfactory work of the operation service of low- and medium-pressure reservoirs.

Based on the analysis of existing problems, when designing a stilling basin and an apron for low and medium-pressure water outlet structures, scientific solutions are given to the following problems: calculation of the conjunction of pools, selection of forms and parameters of various energy absorbers, ensuring the absence of unfavorable modes of a repulsed jump, failure, etc. with various schemes of maneuvering shutters. In addition, it is required to determine the laws of distribution of flow velocities, averaged, and pulsating pressures of the water flow in the structure for various water flow regimes.

Based on these experimental data, it is possible to determine the dimensions of the length and thickness of the slabs of the stilling basin and apron. These solutions increase the level of strength and stability of the structures.

2 Methods

Calculating the strength of reinforced concrete elements [79, 91] primarily includes calculating the stability of the stilling basin and apron.

The condition for stability of the floating state of a structural element of a structure upon ascent to the water surface is taken in the following form

$$|G_{nл}| \geq P_b \quad (1)$$

where, $G_{nл}$ is the mass of the slab, taking into account the force of the rise of water; P_b is the total hydrodynamic stress.

Stability condition for overturning concerning the top and bottom edges of the slab:

$$0.5L_n G_{nл} \geq P_i l_i \quad (2)$$

here, $L_n - G_{nл}$ arm of the force;

P_i is the sum of hydrostatic and pulsation forces;

$l_i - P_i$ arm of the force;

In the presence of an absorber, the stability condition concerning horizontal shear

$$(G_{nл} - P_b) f \geq P_z \quad (3)$$

here, f is the coefficient of friction;

P_z is horizontal force affecting one absorber

According to ShNK 2.06.01-97, the stability condition has the following form:

$$n_m P_z \leq \frac{m}{K_u} |G_{nл}| \quad (4)$$

here, n_m is stress compliance factor;

m is the coefficient of working conditions;

K_u is reliability coefficient.

Formula (4) can also be expressed in the following form:

$$n_m P_i \leq 0.5 L_n |G_{ni}| \frac{m}{K_u} \quad (5)$$

$$n_m P_z \leq \frac{m}{K_u} |G_{ni} - P_b| f$$

Above, we talked about the proposed results of experimental studies; the sensors used in the tests made it possible to determine hydrodynamic stresses depending on the size of stilling basin and apron [61, 79, 114]. Based on these studies, we obtained graphs with dimensions for specific pulsating vertical stresses (p'). These graphs are built separately for slabs of different sizes (l/d), absorbers, and modes. These graphs are compiled for areas with maximum pulsation stresses. Such areas are areas located behind the first and second rows of absorbers.

We know that the total hydrodynamic stress consists of the sum of two components:

$$P_b = \bar{P}_b + P'_{b \max} \quad (6)$$

in this case, \bar{P}_b is the average vertical component of the hydrodynamic stress over time; $P'_{b \max}$ is the maximum value of the pulsation stress component, which depends on the flow turbulence.

The maximum amplitude of the stress pulsation in the calculation of stability and endurance is determined using the following formula:

$$P'_{b \max} = K_A P'_b \quad (7)$$

here K_A is the maximum stress factor. Depending on the structure classification $K_A = 3,0 \div 6,0$. This also applies to moment pulsation stresses $P'_{m \max}$ and horizontal pulsation stresses $P'_{r \max}$.

It should also be noted that in the zone of the stilling basin, in places with the highest average pressure values, the pulsation pressure has a minimum value. In this regard, it can be concluded that hydrodynamic stresses arise in the front and next to the front zones of the first row absorbers.

3 Results and discussion

After determining the conditions for stability and strength of structural slabs with stress-absorbing devices, the calculations of stilling basin and apron are carried out in the following order:

1. The total comparative specific energy of the flow flowing out of the pipe for these energy absorbers is determined:

$$\frac{\mathcal{E}_1 + p}{h_1} = \frac{h_1 + \frac{\alpha v_1^2}{2g} + p}{h_1} \quad (8)$$

2. Average stresses are calculated:

- Using the data obtained, the time-averaged value of the vertical component of the hydrodynamic stress affecting the slab of the water well is determined:
- For the selected absorber, the resistance coefficient is determined by the expression $(\Theta_1 + p)/h_1$ and type of absorber.

In the next stage, the formula determines the average horizontal stresses over time, which affects the energy absorber.

3. The pulsation components of stresses are determined:

- Taking into account the length of the slab and the total specific energy of the flow $(\Theta_1 + p)/h_1$, determined on their basis, we accept the specific standard value of the

pulsation stress $\left(\frac{P'_g}{\alpha v_1^2 / 2g} \right)$;

- For these hydraulic modes, as mentioned above, the specific value of the pressure pulsation of the vertically distributed stress is determined, which is equivalent to the

overturning moment $\left(\frac{P'_M}{\alpha v_1^2 / 2g} \right)$;

- The ratio of the horizontal component of the stress pulsation to the average stress (p'_r/\bar{p}_r) is determined. For certain values of the average horizontal stress component (\bar{p}_r) , the pulsation horizontal component is determined on the basis of part b of paragraph 2.

General hydrodynamic stresses are determined using the following formulas, respectively:

$$\begin{aligned} P_b &= \bar{P}_b + P'_{b \max} \\ P_M &= \bar{P}_M + P'_{M \max} \end{aligned} \quad (9)$$

here $P'_{b \max}$ is the vertical pulsation stress; $P'_{M \max}$ is the vertical stress equivalent to the overturning moment.

Horizontal stress affecting one absorber

$$P_z = \bar{P}_z + P'_{z \max} \quad (10)$$

The thickness of the slabs under vertical stress is determined based on the following condition: the total hydrodynamic load for conditions where the slab can float to the water surface about the top and bottom edges is determined in stages.

Ensuring the stability of the slab for overturning is realized when the following condition is met:

$$|G_{nl}| \geq P_b \quad (11)$$

$$t = \frac{P_b}{(\gamma_\sigma - \gamma)L_n b} = \frac{P'_{b \max} + \sum_{i=1}^n \bar{P}_i}{\gamma_\sigma - \gamma} \quad (12)$$

In this case, the average vertical (\bar{P}_b) and pulsation (P'_b) loads are determined as functions of quantities without units of measurement $(\mathcal{E}_1 + p)/h_1$, L_{nn}/h_1 n, depending on the absorber schemes used in the downstream.

The thickness required to provide resistance against the ascent to the water surface of the slab of the stilling basin concerning the upper and lower edges is determined by the following condition:

$$0.5L_{nn}G_{nn} \geq P'_i l_i \quad (13)$$

$$t = \frac{P'_{m\max} + \sum_{i=1}^n \bar{P}_i l_i}{0.5L_n^2 b (\gamma_\sigma - \gamma) b} = \frac{P'_{m\max} + \frac{\sum_{i=1}^n \bar{P}_i l_i}{0.5L_n^2 b} + \frac{\sum_{i=1}^n P'_i l_i}{0.5L_n^2 b}}{\gamma_\sigma - \gamma} \quad (14)$$

Based on the above method, calculations of the strength of the outlet structures of the downstream of several reservoirs were performed.

Calculations were made for a flat stilling basin with energy absorbers of water outlet structures and a deep stilling basin; the results were compared and analyzed.

Discharge at the water outlet structure ($Q = 50 \text{ m}^3/\text{s}$), the average flow velocity in the compressed section is $v_1 = 3.0 \text{ m/s}$, average flow velocity in front of the first row of absorbers $v_{1c} = 2.5 \text{ m/s}$, flow velocity in front of the stilling basin wall $v_{2c} = 2.0 \text{ m/s}$, the first conjugate depth $h'_c = 1.0 \text{ m}$. The design of the stilling basin shown in Fig. 3.1., which consists of two slabs $L_n = 10 \text{ m}$ long each. The difference between the bottom of the pipe and the bottom of the downstream

$p = 1.0 \text{ m}$. Downstream depth $h_{n\sigma} = 2.0 \text{ m}$.

1. Using the following formula, the total specific energy of the flow is calculated:

$$\frac{\mathcal{E}_1 + p}{h_1} = \frac{h_1 + \frac{\alpha v_1^2}{2g} + p}{h_1} = \frac{1 + \frac{3.5^2}{20} + 1}{1} = 2.5$$

2. Calculate the average stress.

3. Based on the design scheme shown in Fig. 1., in a non-drainage state, the thickness of the slab is determined by the following formula based on the condition of stability against its ascent (1) (the calculation is carried out for a slab thickness of 1 m).

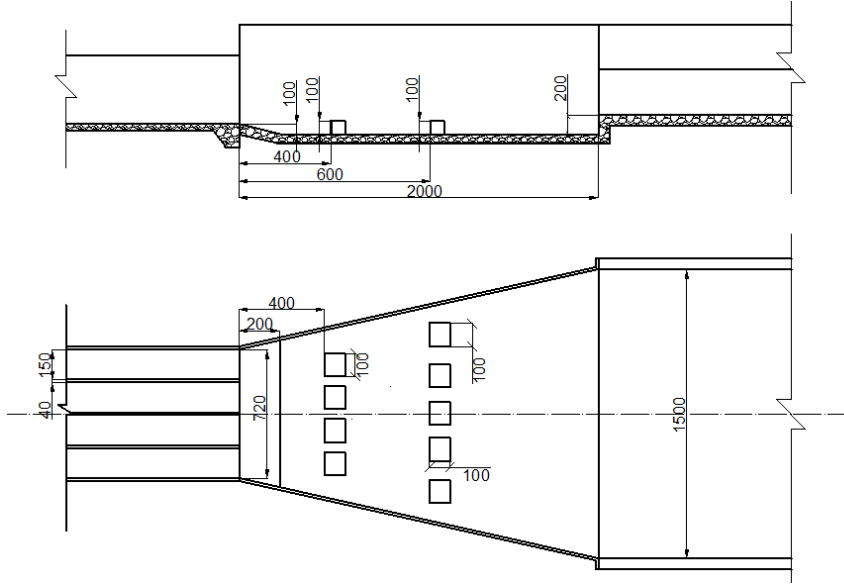

Fig.1. The downstream structure of the reservoir spillway structure selected for calculations (dimensions in sm)

$$t = \frac{P'_{b\max} + \frac{\sum_{i=1}^n \bar{P}_i}{L_n}}{\gamma_6 - 1}$$

$$t = \frac{P'_{M\max} + \frac{\sum_{i=1}^n \bar{P}_i l_i}{0.5L_n^2} + \frac{\sum_{i=1}^n P_c l_c}{0.5L_n^2}}{\gamma_6 - 1}$$

here, \bar{P}_i and l_i are the arm of the force obtained from the diagram of the lack of pressure and the average pressure (Fig. 2).

$$\begin{aligned} \sum \bar{P}_i &= \bar{P}_1 - \bar{P}_2 + \bar{P}_3 - \bar{P}_4 = 0.5 \cdot 1.9 \cdot 1.4 - 0.5 \cdot 2.6 \cdot 2.18 + \\ &+ 0.5 \cdot 4 \cdot 2.07 - 0.5 \cdot 2 \cdot 2.05 + 0.5 \cdot 10 \cdot 1.91 = 1.33 - 2.83 + 4.14 - \\ &- 2.05 + 9.55 = 1014 tk = 1014 kN \\ \sum \bar{P}_i l_i &= \bar{P}_1 l_1 - \bar{P}_2 l_2 + \bar{P}_3 l_3 - \bar{P}_4 l_4 = 1.33 \cdot 19 - 2.83 \cdot 17 + 4.14 \cdot 14 - \\ &- 2.05 \cdot 11 + 9.55 \cdot 8 = 25.27 - 48.18 + 57.96 - 22.55 + 76.4 = 88.9 tk \cdot m = 889 kN \cdot m \end{aligned}$$

Medium stresses exerting the walls of the stilling basin and the energy dissipator

$$\sum P_c l_c = \frac{P_c \cdot 4}{B_1} l_c + \frac{P_d}{B_2} l_d \quad \bar{P}_c = \gamma \omega_c C v_{front}^2 / 2g$$

Here, $\omega_r = 1.0 m^2$ is the upwind surface of one absorber located above the slab; $C = 1.2$ is absorber resistance coefficient in the design mode; $v_{front} = 2.5 m/s$ is speed in the front part of the 1st row of the absorber.

$$\bar{P}_{c1} = \gamma \omega_c C_c v_{\text{front}}^2 / 2g = 1 \cdot 1 \cdot 1.2 \cdot \frac{2.5^2}{19.62} = 0.38 \text{ tk} = 3.8 \text{ kN}$$

$$\bar{P}_{c2} = \gamma \omega_c C_c v_{\text{front}}^2 / 2g = 1 \cdot 1 \cdot 1.2 \cdot \frac{2.0^2}{19.62} = 0.24 \text{ tk} = 2.4 \text{ kN}$$

$B_1=10 \text{ m}$, $B_2=13 \text{ m}$ are the width of the stilling basin at the site of the absorber installation on the lower edge of the alignment; $l_c = t + 1.4/2 - \bar{P}_c$ is arm of force, here this arm is taken concerning the starting point under the following conditions

$$t = 2.5 \text{ m}, l_c = \frac{2}{3}h_c = 3.2$$

$$\sum \bar{P}_c l_c = \bar{P}_{c1} l_{c1} + \bar{P}_{c2} l_{c2} = \frac{0.38 \cdot 4}{10} \cdot 0.67 + \frac{0.24 \cdot 5}{13} \cdot 0.67 = 0.1 + 0.06 = 0.16 \text{ tk} = 1.6 \text{ kN}$$

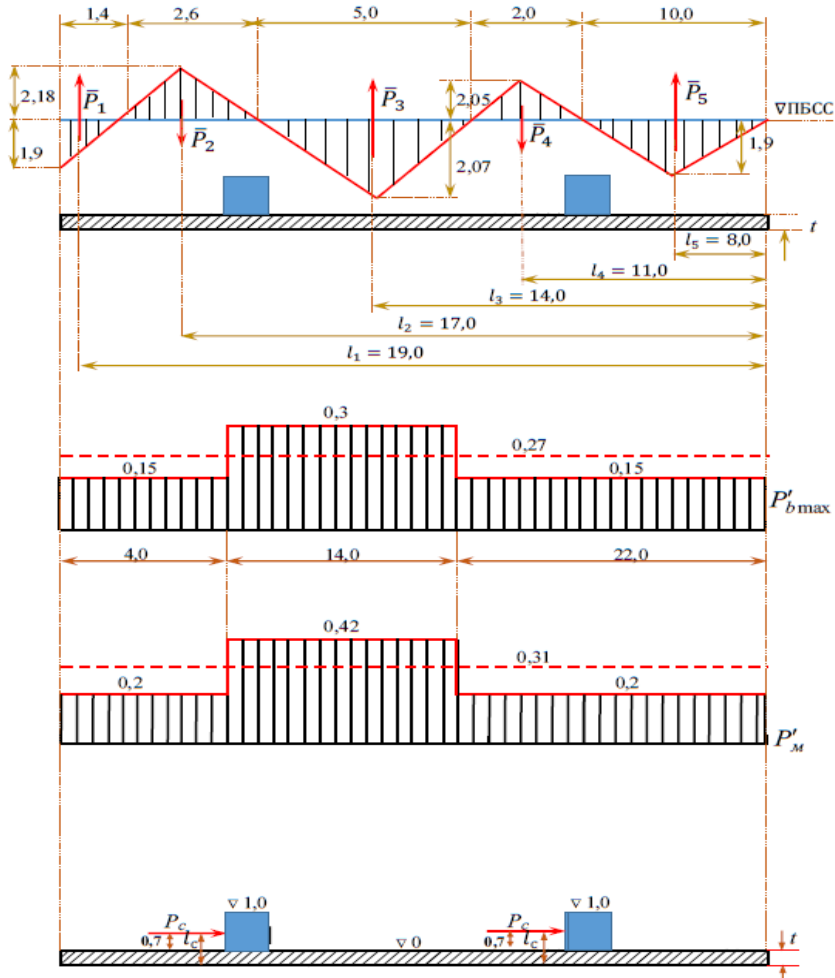

Fig. 2. Scheme for calculating the hydrodynamic stress on the slabs of the stilling basin of the water outlet

Determination of pulsation stress components. Relative standard of vertical stress pulsation. (from the graph in Fig. 2.).

$$P'_b = 0.045 \frac{\gamma v_1^2}{2g} = 0.045 \cdot \frac{1 \cdot 3^2}{19.62} = 0.02 \text{ tk/m}^2 = 200 \text{ Pa}$$

The relative standard equivalent to the vertical pulsating overturning moment is determined from Fig. 3.2:

$$P'_{.M} = 0.055 \frac{\gamma v_1^2}{2g} = 0.055 \cdot \frac{1 \cdot 3^2}{19.62} = 0.025 \text{ tk/m}^2 = 250 \text{ Pa}$$

We define the following

$$P'_c = 0.3 \bar{P}_c = 0.3 \cdot (0.38 + 0.24) = 0.186 \text{ tk} = 1.86 \text{ } \kappa H.$$

To estimate the maximum extreme value of the amplitude of the pulsating stress exerted on the slab of the stilling basin, we calculate the coefficient K_A , determined by the ratio to the maximum value of the arithmetic mean value of the deviation from the probability of occurrence p_0 , taken to skip the estimated time T :

$$K_A = \sqrt{\frac{2 \ln \frac{T/\tau_0}{2 \ln 1/p_0}}{2 \ln 1/p_0}} \quad (15)$$

Here the characteristic time can be calculated as follows:

$$\tau_0 = \pi \frac{\sqrt{\int_0^{\infty} S(\omega) d\omega}}{\sqrt{\int_0^{\infty} \omega^2 S(\omega) d\omega}} \quad (16)$$

For class I structures, we take the ratios $T/\tau_0 = 10^6$ and $p_0 = 0.95$, and take the value $K_A = 6$ [79].

In this case, the extreme specific stress for the slab of the water well is equal to:

$$P'_{b \max} = K_A P'_b = 6 \cdot 0.02 = 0.12 \text{ tk/m}^2 = 1200 \text{ Pa}$$

$$P'_{.M \max} = K_A P'_{.M} = 6 \cdot 0.025 = 0.15 \text{ tk/m}^2 = 1500 \text{ Pa}$$

Putting all the calculation formulas in place, we get the following:

$$t = \frac{P'_{b \max} + \frac{\sum_{i=1}^n \bar{P}_i}{L_n}}{\gamma_\phi - 1} = \frac{0.12 + \frac{10.14}{20}}{2.4 - 1} = \frac{0.627}{1.4} = 0.45 \text{ m}$$

$$t = \frac{P'_{m\max} + \sum_{i=1}^n \bar{P}_i l_i + \sum_{i=1}^n P_c l_c}{\gamma_6 - 1} = \frac{0.15 + \frac{88,9}{0.5 \cdot 20^2} + \frac{0.16}{0.5 \cdot 20^2}}{2.4 - 1} = \frac{0.15 + 0.445 + 0.001}{1.4} = 0.50 \text{ m.}$$

According to the condition of ascent, having overturned the resistance of the slab, we accept the first condition as the main one since it is greater than the shear condition. That is, the accepted slab thickness is 0.5 m.

4 Conclusions

According to the calculation results, the main stresses are vertical and overturning moment stresses, consisting of the average and pulsation components of the stability of the slabs of the stilling basin. Horizontal stresses, to which a small value of the overturning moment is added, have an imperceptible influence in determining the thickness of the stilling basin slab. This allows us to think that it is possible to increase the efficiency of energy absorbers without increasing the thickness of the slab of the downstream stilling basin for water outlet structures of reservoirs. Thus, it is possible to increase energy dissipation by increasing the number of absorbers or the absorption surface.

References

1. Boccotti P. On a new wave energy absorber. *Ocean Engineering*, 30(9), 1191-1200. (2003).
2. Cushman R. M. Review of ecological effects of rapidly varying flows downstream from hydroelectric facilities. *North American journal of fisheries Management*, 5(3A), 330-339. (1985).
3. De Vriend H. J., and Geldof H. J. Main flow velocity in short river bends. *Journal of hydraulic engineering*, 109(7), 991-1011. (1983).
4. Khidirov S., Norkulov B., Ishankulov Z., Nurmatov P., and Gayur A. Linked pools culverts facilities. In *IOP Conference Series: Materials Science and Engineering*, Vol. 883, No. 1, p. 012004. (2020).
5. Rozanov N. P., and Kubetskii V. L. Evaluation of the state of the dam and foundation of the sayano-shushenskoe hydroelectric station and measures to ensure its reliability (based on materials of the expert commission formed by the Engineering Academy of the Russian Federation). *Hydrotechnical Construction*, 28(2). (1994).
6. Norkulov, B. M., Khidirov, S. K., Tadjieva, D., Nurmatov, P., & Suyunov, J. (2023, March). Study of kinematic structure of low flood of water supply facilities. In *AIP Conference Proceedings* (Vol. 2612, No. 1, p. 020017). AIP Publishing LLC.
7. Norkulov B. M., Khidirov S. K., Suyunov J. S., Nurmatov P. A., Tadjieva D. O., and Rustamova, D. B. Determination of dynamic forces affecting floating structure in pump station water supply channel. In *AIP Conference Proceedings*, Vol. 2612, No. 1, p. 020020. (2023).

8. Khidirov S., Artikbekova F., Azimov A., and Yulchiev D. Hydrodynamic characteristics of water flow in area of lower pool junction of spillway structures. In *E3S Web of Conferences*, Vol. 365, p. 03037. (2023).
9. Norkulov B. M., Khidirov S. K., Tadjieva D., Nurmatov P., and Suyunov J. Study of kinematic structure of low flood of water supply facilities. In *AIP Conference Proceedings* Vol. 2612, No. 1, (2023).
10. Bazarov D., Vatin N., Bakhtiyor O., Oybek V., Rakhimov A., and Akhmadi, M. Hydrodynamic effects of the flow on the slab of the stand in the presence of cavitation. In *IOP Conference Series: Materials Science and Engineering* (Vol. 1030, No. 1, p. 012116). (2021).
11. Caska, A. J., & Finnigan, T. D. Hydrodynamic characteristics of a cylindrical bottom-pivoted wave energy absorber. *Ocean Engineering*, 35(1), 6-16. (2008).
12. Choi, W. M., & Kwon, T. S. (2012, March). Variation of kinetic friction coefficient with respect to impact velocity in tube type energy absorbers. In *Proceedings of the 6th international conference on Applied Mathematics, Simulation, Modelling*. World Scientific and Engineering Academy and Society (pp. 30-37).
13. Bazarov, D., & Vokhidov, O. Extinguishing Excess Flow Energy in Spillway Structures. In *Proceedings of EECE 2020: Energy, Environmental and Construction Engineering 3* (pp. 535-545). Springer International Publishing. (2021).
14. Rozanov, N. P., & Kaveshnikov, A. T. Investigation of cavitation damage to baffle piers and flow splitters. *Hydrotechnical Construction*, 7(1), 44-48. (1973).
15. Das, S., & Choudhury, M. R. Overview of energy dissipators and stilling basins with design aspects of hydraulic jump type energy dissipators. (2016).
16. Hager, W. H. *Energy Dissipators: IAHR Hydraulic Structures Design Manuals 9*. Routledge. (2018).