

Automatic water level regulator with flexible working bodies in form of partition structure for trapezoidal channels

Mukaddas-Gaukhar Kadirova *

“Tashkent Institute of Irrigation and Agricultural Mechanization Engineers”, National Research University, Tashkent, Uzbekistan

Abstract. To improve the designs of hydraulic automatic water level regulators with flexible working bodies for channels, the object of research was developing and studying an innovative design of an autoregulator of the water level with flexible working bodies in the form of a partition structure for trapezoidal channels. The study's main purpose was to create a design for trapezoidal channels that do not allow channel narrowing and provides automatic level control, draining excess water, washing deposits in front of the partition, and determining its throughput. The developed design consists of a gate with flexible working bodies and a water level regulator combined with it. The article presents a theoretical formula for determining the flow rate of lateral water flows through the gate of the water level autoregulator. Experimental studies were carried out on an experimental installation by the method of physical modeling using the criterion of geometric similarity of the model and nature. As a result of these studies, simpler formulas were obtained for determining the flow rate of lateral water flows through the gate and a formula for determining the total flow rate of water passing through the gate of the water level autoregulator with flexible working bodies for trapezoidal channels for use during operation.

1 Introduction

Modern trends and the scale of development of hydraulic engineering and land reclamation put forward the problem of effective water level management in the irrigation system, which can be achieved only by automating this process. Currently, much attention is paid to the issues of uninterrupted operation, continuous modernization of irrigation systems and other water management and hydraulic structures, the development and implementation of modern innovative and resource-saving technologies in the water sector, improving the efficiency of the operation of structures on irrigation canals, described in the works of Ya.E. Pulatov [1], T.S. Koshkarova, L.N. Medvedeva, A.A. Novikov, L.A.Voevodina [2], V.N. Shchedrin, S.M. Vasilyev, A.A. Churaev[3], A.A. Aldoshkin[4], E.M. Khalifa, M.A.Eltavil, M.E. Melekh, M.M. Sharaf [5], P.P. Gadj, V. Jotiprakash, V.V. Bhosekar [6].

And to maintain the required water level, the front of the partition structure, and the

*Corresponding author: mukaddas-gauhar1952@yandex.ru

supply of a given constant water flow to the outlets from the channel for economical water consumption by consumers, automation of partition structures is carried out, described in the works of K. M. Melikhov, A. A. Pakhomov, E. A. Kolobanov [7] V. N. Shchedrin, A. A. Churaev, V. M. Shkolnaya, L. V. Yuchenko [8] V. I. Olgarenko, N. S. Stepanov, A. P. Kisarov, I. V. Olgarenko [9], M. I. Balzannikov [10], And A. S. Ovchinnikov, R. Z. Kiseleva, K. M. Melikhov, A. A. Kiselev [11].

The massive use of gates on partition structures of irrigation systems and their remote location from power transmission lines, from the point of view of economic efficiency, shows that their hydraulic automation is most appropriate, that is, equipping them with automatic hydraulic gates, hydraulic level autoregulators operating entirely on renewable hydraulic energy of water flow. They provide economical use of water, saving electricity spent on their operation and reducing operating costs.

In the well-known works of Ya.V. Bochkarev, P.I. Kovalenko, E.E. Makovsky, and others, only some designs of automatic hydraulic gates that have found application in partition structures of irrigation channels are described. They are made of traditional metal materials. Their peculiarity is the presence of a metal gate (flat, segmental, valve, sector) of a certain design and the need to erect a capital structure. This, of course, is expensive and prevents their widespread introduction into production. Due to the rapid development of the chemical industry, flexible rubberized fabric has now appeared as a new type of building material. Their properties: low weight, flexibility, the ability to change shape when the load changes, and high maneuverability, as shown in the works of T. Tomiyama and I. Nishizaki [12], Weston, G. Chartuni, L. Dalton, D. Force, J. Trovillion, K. Zyumbulev, R. Macmillan [13], Novikov S.G., Kutsenko V.N. [14], - create great prospects for their use as flexible organs in hydraulic water level regulators. Therefore, today there are already combined flexible designs of hydraulic valves – automatic machines and autoregulators. These constructions are shown in the well-known works of O.G. Zatvornitsky, B.I.Sergeev and are shown in the works of V.I. Loginov, S.M. Rtischev, V.N. Kozyrev, M.V. Ilemenov, E.D. Mikhailova [15], M.-G.A. Kadirova [16, 17, 18, 19, 20].

However, the main disadvantage of these structures is their inconvenient implementation on channels, which mainly have a trapezoidal cross-section, especially on channels with small slopes, and the lack of the possibility of flushing the channel section from alluvial deposits in front of the partition structure.

2 Methods

The mass use of gates on partition hydraulic structures of irrigation systems naturally puts forward interest in finding simpler designs of such hydraulic automatic gates, the designs of which have the following advantages: lack of metal consumption, ease, cheapness, do not narrow the working section of the channel, can implement with minimal costs on channels of a trapezoidal section, maintainability, environmental cleanliness, etc.

Therefore, the task was sent to develop such an autoregulator of the water level with flexible working bodies, which has these advantages for trapezoidal channels.

To perform the task based on the previously developed design of an autoregulator of the water level with flexible working bodies for partition structures on canals, previously published by Kadirova M.-G. [18], it was necessary to develop an innovative design of a hydraulic autoregulator of the water level with flexible working bodies for channels of trapezoidal cross-section, which does not narrow the cross-section of the channel, ensuring the flushing of sediments to prevent their accumulation in front of the structure, to justify the shapes of its elements, to develop their parameters, dimensions, to derive not only its theoretical formula for determining the throughput taking into account lateral expirations but also based on experimental studies of the model of the proposed design of a hydraulic

level autoregulator with flexible working bodies, to propose simpler formulas for determining its throughput for their use in practice.

Thus, the design of a hydraulic automatic water level regulator with flexible working bodies for a trapezoidal channel was developed, which is shown in Figure 1.

It consists of a tank filled with water and a float water level regulator located next to the autoregulator on the canal bank. The shape of the reservoir of the water-filled gate in the closed position is a triangle in a longitudinal section, with the top lowered down; its width in the transverse direction corresponds to the width of the channel along the bottom. In this case, the pressure part 2 of the gate tank is made flat and rigid in the form of a channel and is located in the longitudinal section at an angle of 45 degrees to the horizon, and the lower and lateral non-pressure parts are made of flexible rubberized meliorative fabric following the shape of the channel.

To reduce the cost of the shutter, it is better to make the clamping part of the shutter 2 in the form of a rigid flat rigid frame covered with a flexible rubberized meliorative fabric. In the closed state, the clamping part of the shutter in the longitudinal section forms an angle of 90 degrees with the non-pressure part of the shutter.

To improve the hydraulic conditions of water outflow from under the shutter, the pressure part 2 of the shutter is equipped with a rigid visor 6 in the lower part. The capacity of the shutter has an inlet 5, the area of which is 4...6 times smaller than the area of the outlet 7. This provides a condition for rapid emptying of the gate tank when the water level in front of the autoregulator rises above the set one. The capacity of the gate 1 is filled through the permanently open inlet pipe 5 and emptied through the outlet pipe 7, equipped with a ball valve 8.

This valve 8 is connected using a cable 10 to a rigid block 11 mounted in the middle of the axis of rotation 12 of the gate. The movement of the valve is limited by guides 9, which allows it to move in the direction of closing and opening the outlet from the reservoir of the gate of the water level autoregulator. At one end of the shutter rotation axis, there is a block 13 rigidly connected to the shutter rotation axis. On one side of this block, a float 15 is suspended on a cable, lowered into the float chamber, and on the other side, a counterweight 14 is suspended from the block.

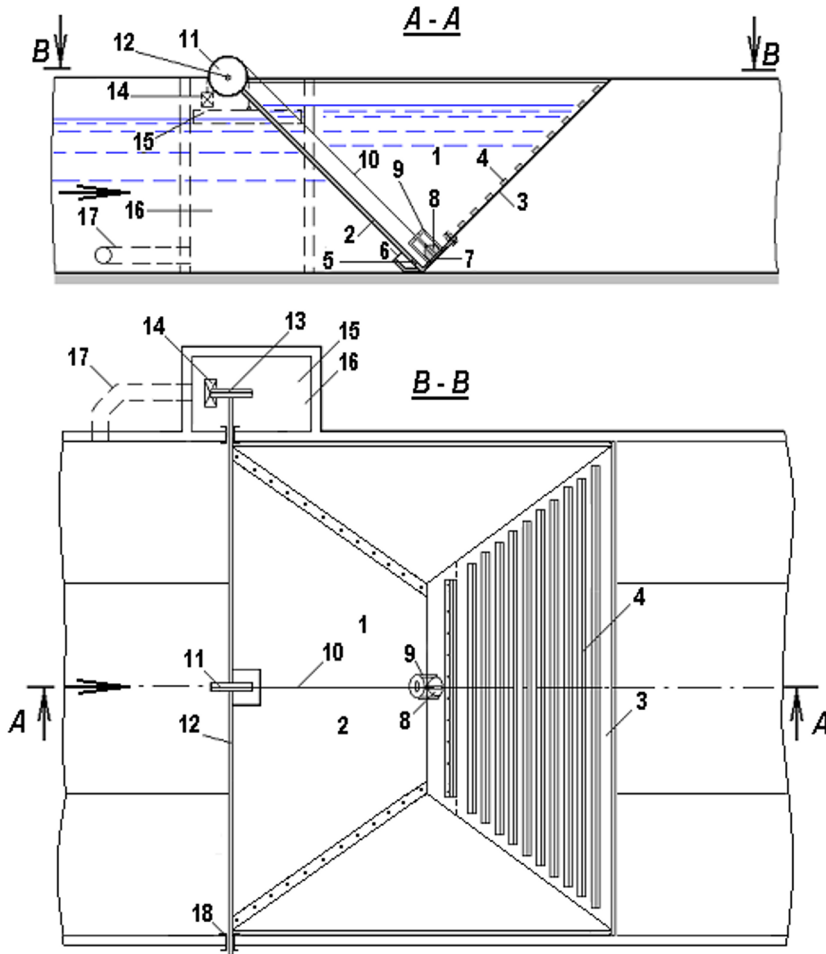

Fig. 1. Autoregulatory of water level with flexible working bodies in form of partition structure for trapezoidal channel.

The capacity of the float chamber, to ensure the same water level in it as in the channel in front of the autoregulator, is communicated by a pipe 17 with a part of the channel in front of the installation site of the autoregulator of the water level with flexible working bodies. The water level regulation on the canal section in front of the autoregulator is carried out as follows. In the absence of water in the channel, the flap of the water level autoregulator is in a closed, lowered state under its own weight; its float is also lowered, and the outlet is closed since its outlet valve is closed. When water appears in the channel, water enters the reservoir for the shutter through the inlet of the reservoir; the shutter is lowered by its own weight and the weight of the water in the reservoir for the shutter. When the water level in the part of the channel in front of the partition structure rises above the set level, the float rises along with the water level. Under the weight of the counterweight, the shutter axis rotates, the block rigidly attached to it rotates with it, and the valve cable connected to it is partially wound onto the block. In this case, the valve is lifted, opening the outlet from the valve capacity of the autoregulator. After that, the weight of the shutter decreases. The pressure part and, consequently, the entire gate rise, increasing the water flow from under the gate. At the same time, the pressure-free and side parts of the autoregulator shutter, made of rubberized meliorative fabric, are folded, thanks to the slats located on the inside

of the pressure-free part of the autoregulator shutter, ensuring that water flows out from under it. As a result, the water level in the channel in front of the autoregulator decreases, the float is lowered, the ball valve closes the outlet, and the capacity of the gate of the autoregulator is filled with water through the constantly open inlet of the gate, its weight increases, and the gate of the autoregulator is lowered, providing an increase in the water level in the channel in front of the autoregulator.

Next, the water level in the channel in front of the autoregulator rises above the set one, and the process is repeated until the set water level is set in the channel in front of the autoregulator. The flow capacity of the gate of the proposed water level autoregulator consists of a water flow flowing out from under the pressure part of the gate and a water flow flowing through its side slits. During the operation of the shutter, the angle of inclination of the clamping part of the shutter θ varies from 45 degrees to 0 degrees.

The water flow rate from under the pressure inclined shield part of the gate at an angle θ to the horizon is determined by the well-known formula described in the work of P.G. Kiselev, A.D. Altshul, N.B. Danilchenko, A.A. Kasparson, G.I. Krivchenko, N.N. Pashkov, S.M. Slisky.

$$Q_1 = \mu a b_p \sqrt{2g(H - \varepsilon a)} \quad (1)$$

where: Q_1 is the flow rate of water from under the shutter of the autoregulator of the water level in the absence of lateral outflows, H is the depth of the water flow in front of the shutter of the autoregulator of the water level, g is the acceleration of gravity, a is the opening height of the shutter of the autoregulator of the water level, b_p is the width of the shutter of the autoregulator of the water level, $b_p = b + 2 \cdot m \cdot a$, where b is the width of the channel along the bottom, $m = \text{ctg } \beta$, where β is the angle of inclination of the channel slope to the horizon, ε is the coefficient of vertical compression of the water flow when the water level regulator flows out from under the shutter.

The flow rate of the water flows through the side gaps of the gate of the autoregulator can be determined theoretically. The scheme of the lateral gap between the pressure part of the gate of the autoregulator and the side wall of the channel is shown in Figure 2, where the following designations are adopted: H is the depth of water in front of the flat pressure part of the gate; r is the height of the center of rotation of the flat pressure part of the gate relative to the bottom of the hole; a is the height of the opening of the flat pressure part of the gate relative to the horizontal.

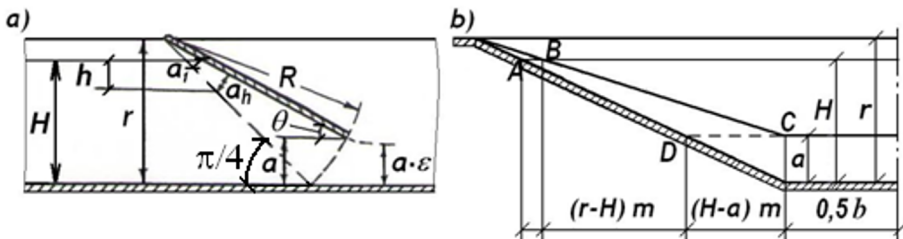

Fig. 2. Diagram of side gap between flat clamping part of shutter and side part of channel opening: a) section through which lateral outflow of water occurs in longitudinal direction, b) section behind gate, through which lateral outflow of water occurs in transverse.

The elementary flow of water through the side gap between the flat pressure part of the gate of the autoregulator of the water level and the side wall of the trapezoidal channel, based on the design scheme in Fig. 2, can be represented as:

$$dQ_2 = u \cdot b_b \cdot d\omega \quad (2)$$

where u is the velocity of water flow through the side gap, ω is the elementary area of the side gap, b_b is the width of the side gap. When substituting into formula (2) the values of the velocity u and the elementary area of the lateral gap ω from the calculation scheme in Fig. 2, the following expression is obtained:

$$dQ_2 = d\omega \cdot b_b \cdot \varepsilon \cdot \varphi \cdot \sqrt{2 \cdot g \cdot h} \quad (3)$$

From the calculation scheme in Figure 2, a formula is obtained for determining the elementary area of the side gap:

$$d\omega = \sqrt{2} / 2 \cdot \sin(\pi/4 - \theta) / \sin\theta \cdot [(c+h)^2 - c^2] \cdot dh \quad (4)$$

where c is a constant value, $c = r - H$.

When substituting the $d\omega$ value into formula (3), the following expression is obtained from formula (4)

$$dQ_2 = \varepsilon \cdot \varphi \cdot b_b \cdot \sqrt{2 \cdot g \cdot h} \cdot \sqrt{2} / 2 \cdot \sin(\pi/4 - \theta) / \sin\theta \cdot [(c+h)^2 - c^2] \cdot dh \quad (5)$$

When integrating the right and left sides of equation (5), it turns out (6)

$$\int_0^{Q_2} dQ_2 = \int_0^H \varepsilon \cdot \varphi \cdot b_b \cdot \sqrt{g} \cdot \sin(\pi/4 - \theta) / \sin\theta \cdot \sqrt{h} \cdot [(c+h)^2 - c^2] \cdot dh \quad (6)$$

As a result of the integration of expression (6), the total water flow through one side gap of the gate of the autoregulator of the water level is equal to

$$Q_2 = 2 \cdot \varepsilon \cdot \varphi \cdot b_b \cdot \sqrt{g} \cdot \sin(\pi/4 - \theta) / \sin\theta \cdot H^{5/2} \cdot (2 \cdot c/5 + H/7) \quad (7)$$

Considering that the width of the side gap will be equal to

$$b_b = [(R - H) \cdot m + m \cdot a] / 2 = m \cdot (c + a) / 2$$

$$Q_2 = \varepsilon \cdot \varphi \cdot m \cdot (c + a) \cdot \sqrt{g} \cdot \sin(\pi/4 - \theta) / \sin\theta \cdot H^{5/2} \cdot (2 \cdot c/5 + H/7) \quad (8)$$

The total flow rate with a free flow of water through the gate of the water level autoregulator will be equal to

$$Q = Q_1 + 2 \cdot Q_2 \quad (9)$$

$$Q = \mu \cdot a \cdot b_p \cdot \sqrt{2 \cdot g \cdot (H - \varepsilon \cdot a)} + 2 \cdot \varepsilon \cdot \varphi \cdot m \cdot (c + m) \cdot \sqrt{g} \cdot \sin(\pi/4 - \theta) / \sin\theta \cdot H^{5/2} \cdot (2 \cdot c/5 + H/7) \quad (10)$$

Considering that the width of the shutter opening of the water level autoregulator, $b_p =$

$b+2ma$, the expression (10) will take the form

$$Q = \mu \cdot a \cdot (b + m \cdot a) \cdot \sqrt{2 \cdot g \cdot (H - \varepsilon \cdot a) + 2 \cdot \varepsilon \cdot \varphi \cdot m \cdot (c + m) \cdot \sqrt{g \cdot \sin(\pi/4 - \theta) / \sin \theta \cdot H^{5/2} \cdot (2 \cdot c/5 + H/7)}} \quad (11)$$

3 Results and Discussion

To clarify the correctness of the theoretical formulas for determining the gate capacity of the proposed design of the water level autoregulator with flexible working bodies, experimental studies were conducted. The experimental setup is shown in Figure 3.

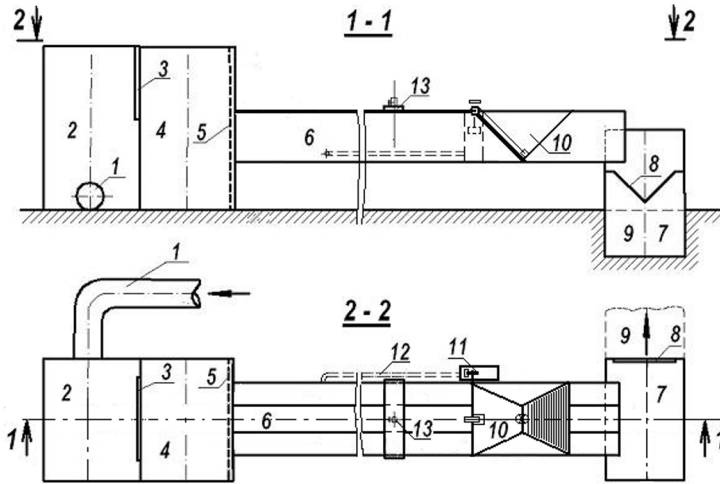

Fig. 3. Scheme of experimental setup: 1 is a pipe supplying water from the pump; 2 is sediment tank No. 1; 3 is a volumetric triangular spillway with a thin wall; 4 is sediment tank No. 2; 5 is a water flow energy extinguisher in the form of a grid; 6 is a trapezoidal section tray; 7 is sediment tank No. 2; 8 is dimensional triangular spillway with a thin Thomson wall; 9 is drainage chute of the spillway; 10 is the model under study; 11 is float water level regulator; 12 is pipe communicating the float chamber of the water level regulator with the section of the tray in front of the model; 13 is a movable shelf with a device installed on it for measuring the water level in the form of a needle with a measurement scale.

It consisted of a trapezoidal tray with a bottom width of 0.5 m, a length of 12 m, and a height of 0.5 m, with an angle of inclination of the channel slope, a tray to the horizontal β , on an experimental installation $\text{ctg } \beta = m = 1.5$. The maximum flow rate of water supplied to the tray was $0.0561 \text{ m}^3/\text{s}$. The tray had a closed water supply system, which was supplied by a pump. Modeling of the studied phenomena was carried out according to the criteria of Froude's gravitational similarity, the dynamic similarity of forces, similarity criterion of dynamic processes under the action of elastic forces (Cauchy criterion).

These criteria are described in the well-known work of P.G. Kiselev, A.D. Altshul, N.B. Danilchenko, A.A. Kasparson, G.I. Krivchenko, N.N. Pashkov, S.M. Slisky and the works of V.A. Prokofiev, G.A. Sudolsky [21], A.I. Esin [22], M.I. Balzannikova [23], Yu. Kim, G. Choi, H. Park, and S. Ben [24]. The research was carried out by the method of physical modeling, using the criterion of geometric similarity of the model and nature at Reynolds numbers $Re = 7145 \dots 56202 > Re_{kr} = 300$, which corresponds to the quadratic resistance region for open channels and Froude numbers $Fr = 0.51 \dots 10.5$ with self-similarity of the phenomena under consideration.

Modeling of elastic material was carried out according to the maximum linear tension

according to the well-known recommendations of A.P. Nazarov. The scale of the models concerning nature was adopted 1:4.

Two models were used to study the throughput, one model of a water-filled gate of an autoregulator of the water level with flexible working bodies in the form of a partition structure with a trapezoidal section of the channel, shown in Figure 1, and the other model, made in the form of a pressure plane, designed to study the flow through the side gaps of the gate, is shown in Figure 4.

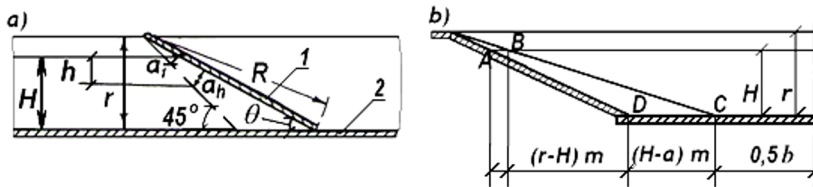

Fig. 4. Model for study of water flow only through side opening of pressure flat part of gate in form of board made of organic glass rigidly mounted in trapezoidal section tray; 1 is a flat board made of organic glass; 2 is a horizontal board installed between the walls of an organic glass tray with a thickness of 10 mm; a) a side view, in a longitudinal section; b) a view from the side located behind the installation site of the model.

The model shown in Fig. 4 was a board having a width of 0.5 m from the bottom, a width of 2 m from the top, and a length equal to 0.71 m. It was investigated as a flat pressure board to determine the water flow through its side gaps without outflow from under it. This model was installed in a trapezoidal cross-sectional tray of an experimental installation with fixed angles θ from 40 to 10 degrees between a flat pressure board installation line and a horizontal bottom. At the same time, the horizontal bottom made of plastic was installed horizontally between the walls of the trapezoidal tray of the experimental installation in such a way that there was no leakage from under the flat pressure board. Studies of the model shown in Fig. 4 were carried out at fixed angles: $\theta = 10^\circ; 15^\circ; 20^\circ; 25^\circ; 30^\circ; 35^\circ; 40^\circ$. The interval of change of the fixed angle was taken in the range $\theta = 5$ degrees to take into account the spread of experimental points when constructing the dependence of the flow rate of lateral flows $Q_2 = f(a/H)$. The flow rate of water passing through the tray was measured using a triangular measuring spillway with a thin Thomson wall; the water level was measured using a needle equipped with a scale for measuring the water level, the angle of inclination of the flat pressure part of the gate in the form of a board of organic glass was rigidly fixed on a horizontal rigid plane of organic glass 10 mm thick, installed between the walls trapezoidal tray of the experimental installation, when fixing the angle size was set using a protractor.

The investigated model of the water level autoregulator with flexible working bodies is shown in Fig. 1. It was located in the tray of the trapezoidal cross-section of the experimental installation, having a width of 0.5 m at the bottom, a width of 2 m at the top and a height of 0.5 m.

The model of the water level autoregulator with flexible working bodies had a pressure part of the flap in the form of a flat board having a width of 0.494 m from the bottom and a width of 1.994 m from the top. The length of the board was 0.71 m, and the side gaps of this pressure part in the form of a flat board were 0.003 m on each side when it was closed as part of the water level autoregulator. The float chamber was located to the side of the outside of the investigated model of the water level autoregulatory, next to a trapezoidal tray on a stand. The inlet to the tank gate of the water level autoregulator had a diameter of 0.025 m, the outlet had a diameter of 0.05 m, and the ball valve had a diameter of 0.06 m.

The capacity of the float chamber of the water level autoregulator model with flexible working bodies was communicated by a pipe with a diameter of 0.04 m and a length of 1.5 m with a tray capacity in the area in front of the installation site of the model.

The float of the device for fixing the water level was made of foam. The float chamber had a rectangular shape, its width was 0.08 m, and its length was 0.10 m. The depth of the float chamber was assumed to be 0.5 m. The float had the following dimensions: width 0.075 m, length 0.095 m, and thickness 0.06 m.

The main part of all experiments was carried out with a sequential increase in water flow rate. All parameters were measured after 15 minutes...20 minutes after changing the water flow rate or another parameter. At this time, the tray was set to a constant water flow rate.

To determine the flow rate of lateral outflows during the study of the shutter of the water level autoregulator with flexible working bodies, its model was studied, shown in Figure 4, on the experimental installation, Figure 3.

In the studies, the total flow of water passing through the tray was measured by a triangular spillway with a thin Thomson wall installed downstream behind the model of an autoregulator of the water level in the spillway trench. During the studies, water flow rates Q from 0.005 m³/s to 0.0561 m³/s were passed through the tray; the initial state was assumed when there was no water flow during transit. The water flow rate Q passing through the gate of the autoregulator of the water level, considering the lateral outflows, was determined by a triangular spillway with a thin Thomson wall.

The flow rate of outflow from under the shutter of the autoregulator of the water level was determined as:

$$Q_1 = Q - Q_2 \quad (12)$$

where: Q is the total flow rate of water passing through the tray, Q_2 is the flow rate through the side gaps of the gate of the water level autoregulator with flexible working bodies.

As a result of the conducted research, dependency graphs $Q_1/(Q_1 + Q_2) = f_1(a/H)$ and $Q_2/(Q_1 + Q_2) = f_2(a/H)$, represented in Figures 5 and 6.

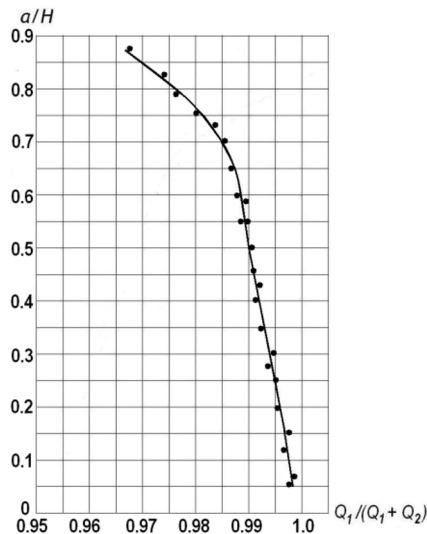

Fig. 5. Graph of dependence $Q_1/(Q_1 + Q_2) = f(a/H)$. ((The dots show the data obtained as a result of experimental studies).

When mathematically processing experimental data by the finite difference method at $0.05 < a/H < 0.90$, the following dependence of the ratio of the flow rate flowing from under the flap of the water level autoregulator with flexible working bodies relative to the total flow rate of water passing through this flap (FIG. 5), mounted on a tray of trapezoidal cross-section, with an angle of inclination the lateral part of the pallet to the horizon, the cotangent of which is equal to 1.5:

$$Q_1/(Q_1 + Q_2) = \left[\frac{(0.875 - \frac{a}{H})}{1660} \right]^{1/2.3} + 0.967 \quad (13)$$

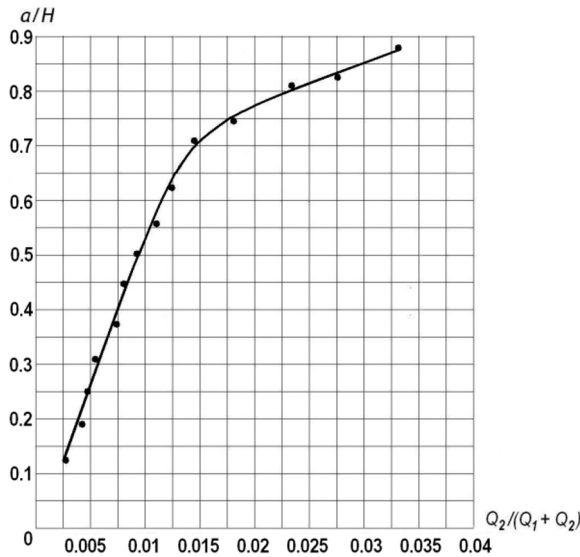

Fig. 6. Graph of dependence $Q_2/(Q_1 + Q_2) = f(a/H)$. (Dogs show the data obtained as a result of experimental studies).

By mathematical processing of experimental studies by the method of finite differences at $0.05 < a/H < 0.90$, the following dependence of the ratio of outflows through the side gaps of the gate of the water level autoregulator with flexible working bodies relative to the total water flow going through the gate of the water level autoregulator with flexible working bodies mounted on a tray of trapezoidal cross-section, with an angle of inclination of the lateral parts of the tray to the horizon, the cotangent of which is 1.5, (fig. 6):

$$Q_2/(Q_1 + Q_2) = \left| 0.56(0.88 - a/H)^{1.25} - 0.035 \right| \quad (14)$$

4 Conclusions

To improve the designs of hydraulic automatic water level regulators with flexible working bodies for channels and eliminate the shortcomings of previously developed designs of automatic valves, hydraulic water level regulators with flexible working bodies, the article presents an innovative design of an automatic water level regulator with flexible working bodies for channels, which does not narrow the trapezoidal section of the channel and does

not require high costs during implementation.

1. A theoretical formula (8) is derived for determining the flow rate of water flowing through the side gaps of the gate of the water level autoregulator with flexible working bodies for trapezoidal channels.

2. As a result of the conducted experimental studies, an empirical dependence (13) of the ratio of the flow rate of water flowing from under the gate of the water level autoregulator with flexible working bodies to the total flow rate passing through it for channels of trapezoidal cross-section, with the angle of inclination of the lateral part of the channel to the horizon, the cotangent of which is 1.5, depending on the ratio of height opening of the water level autoregulator gate with flexible working bodies to the water pressure in front of it, $Q_1/(Q_1+Q_2) = f(a/H)$, which is consistent with experimental data, given in the work with an accuracy of + 5...6 percent.

3. As a result of the conducted experimental studies, an empirical dependence (14) of the ratio of the flow rate of water flowing through the side gaps of the gate of the autoregulator of the water level with flexible working bodies to the total flow rate flowing through it, depending on the ratio of the opening height of the gate of the autoregulator of the water level with flexible working bodies to the water pressure in front of it, $Q_2/(Q_1+Q_2) = f(a/H)$ for trapezoidal channels, while the angle of inclination of the lateral part of the channel to the horizon has a cotangent equal to 1.5, which is consistent with experimental data, given in the article, with an accuracy of +5...6 percent.

4. With an increase in the ratio of the flap opening to the pressure in front of it, $a/H = 0.1 \dots 0.875$, the flow through the side gaps of the flap of the water level autoregulator with flexible working bodies has a slight tendency to increase in the range from 0.16 to 3.35 percent of the value of the total water flow passing through the flap for trapezoidal channels, at the angle of inclination of the lateral part of the channel to the horizontal, the cotangent of which is 1.5.

5. The proposed design of the water level autoregulator with flexible working bodies works entirely on the energy of a moving water flow, does not require electricity, has an acceptable accuracy of water level regulation within + 5%, does not narrow the channel cross-section, which is very important on channels with small slopes, has a low cost, 5...7 times lower than traditional metal automatic gate designs, does not pollute the environment, is easy to operate, does not require much labor during installation and installation, can be manufactured and repaired by operating organizations, maintainable, recommended as an automatic blocking structure for channels of a trapezoidal section of the irrigation system.

References

1. Pulatov Ya.E. 2017. Vodosberegayushchie tekhnologii orosheniya i effektivnost' ispol'zovaniya vody v sel'skom khozyaystve. //Journal Ekologiya i stroitel'stvo [Ecology and Construction]. Tajikistan, no. 4, pp. 21-26. (In Russian).
2. Koshkarova T.S., Medvedeva L.N., Novikov A.A., Voyevodina L.A., 2020. Organization of water accounting and water saving of irrigation water based on world experience in the conditions of changing climate. IOP Conference Series: Earth and Environmental Science, 14 Oct., vol. 577, iss. 1, article number: 012013, DOI: 10.1088/1755-1315/577/1/012013.
3. Shchedrin V.N., Vasiliev S.M., Churaev A.A., 2013. Kompleksnyy podkhod k otsenke pokoleniy orositel'nykh system na osnove sredstv imitatsionnogo modelirovaniya slozhnykh sistem. //Izvestiya Nizhnevolzhskogo agrouniversitetskogo kompleksa: Nauka i vyssheeprofessional'noe obrazovanie [Bull. of Nizhnevolzhsky Agro-University Complex: Science and Higher Professional Education], no. 4(32), pp. 189-193.

4. Aldoshkin A.A., 2020. Kontseptsii neobkhodimosti razrabotki innovatsionnykh tekhnologiy stroitel'stva orositel'nykh sistem. // Vestnik meliorativnoy nauki [Bulletin of Reclamation Science], no. 2, pp. 58-65. (In Russian).
5. Khalifa, E. M., Eltawil, M. A., Meleha, M. E., & Sharaf, M. M. (2009). Enhancing the irrigation water management using developed irrigation canals. // Journal of Soil Sciences and Agricultural Engineering, 34(6), 7481–7503. <https://doi.org/10.21608/jssae.2009.103878>
6. Gadge, P. P., Jothiprakash, V., & Bhosekar, V. V. (2019). Hydraulic design considerations for orifice spillways. // ISH Journal of Hydraulic Engineering, 25(1), 12–18. <https://doi.org/10.1080/09715010.2018.1423579>
7. Melikhov K.M., Pakhomov A.A., Kolobanova N.A., 2016. Vozmozhnost' avtomatizatsii podachi zadannogo raskhoda vody naotkrytykh orositel'nykh sistemakh. // Mezhdunarodnyy nauchno-issledovatel'skiy journal [International Scientific Research Journal], no. 10(52), pp. 161-163. (In Russian).
8. Shchedrin V.N., Churaev A.A., Shkolnaya V.M., Yuchenko L.V., 2015. [Simulation of dynamic management of water distribution at canals of open irrigation network]. // Nauchnyy Journal Rossiyskogo NII Problem Melioratsii, no. 4(20), pp. 1-20, available: <http://www.rosniipmsm.ru/article?n=819> [accessed 01.11.2021]. (In Russian).
9. Olgarenko V.I., Stepanova N.S., Kisarov O.P., Olgarenko I.V. 2012. Matematicheskoe modelirovanie i issledovanie techeniy v Miussskoy orositel'noy sisteme na imitatsionnoy modeli. // Izvestiya YUFU [Bull. YuFU], no. 6(131), pp. 52-56. (In Russian).
10. Balzannikov M.I. Osnovnye metody sovershenstvovaniya konstruksij zatvorov gidrotekhnicheskikh sooruzhenij. // News of Higher Educational Institutions. Construction. No. 12, 2018. Pp. 94-108. (In Russian).
11. Ovchinnikov A.S., Kiseleva R.Z., Melikhov K.M., Kiselev A.A. Automatic regulators for equipment of hydrotechnical structures for rice irrigation. // The journal. // Journal "Izvestiya Nizhnevolzhskogo Agrouniversitetskogo kompleksa: Nauka i vysshee professional'noe obrazovanie". No.1 (65), 2022, pp. 342-351. DOI: 10.32786/2071-9485-2022-01-33 (in Russian)
12. Tomiyama, T., & Nishizaki, I. (2020). Applicability of fiber reinforced plastics to hydraulic gates. In Composites in Civil Engineering, CICE 2006, pp. 453–456. International Institute for FRP in Construction (IIFC).
13. Weston D., Chartouni G., Dalton L., Force D., Trovillion J., Zumbulev K., McMillen R. (2021). Use of composite material for sector gates and vertical lift gates. In World Environmental and Water Resources Congress 2021: Planning a Resilient Future along America's Freshwaters - Selected Papers from the World Environmental and Water Resources Congress 2021 (pp. 116–121). American Society of Civil Engineers (ASCE). <https://doi.org/10.1061/9780784483466.011>
14. Novikov S.G., Kutsenko V.N. Innovative mobile flexible protective hydrotechnical structures from composite materials. // The journal "Provincialnye zapiski" No.1(9), 2019, pp.114-117. CHOU VO Regionalnyy otkrytyy sotsialnyy institute. Kursk. (In Russian)
15. Loginov V.I., Rtishchev S.M., Kozyrev V.N., Ilemenov M.V., Mikhaylova E.D. Development and application of pre-erected hydraulic structures based on mobile water-filling dams to protect infrastructure in emergency situations associated with dangerous hydrological phenomena. // Journal of Hydraulic engineering construction. The Ministry of Energy of the Russian Federation PJSC "RusHydro". No. 2. 2020, pp. 14-

20. (in Russian)
16. Hydraulic automatic regulator of level with flexible working bodies. To cite this article: *Mukaddas-Gaukhar* Kadirova. Tashkent Institute of Irrigation and Agricultural Mechanization Engineers, E3S Web of Conferences 264, 03039 (2021) *CONMECHYDRO – 2021*. <https://doi.org/10.1051/e3sconf/202126403039>
 17. The shutter-automatic machine throughput of the washing device of the water level automatic regulator. To cite this article: *Mukaddas-Gaukhar* Kadirova Tashkent Institute of Irrigation and Agricultural Mechanization Engineers, E3S Web of Conferences 264, 03065 (2021) *CONMECHYDRO – 2021* <https://doi.org/10.1051/e3sconf/202126403065>
 18. Autoregulatory of water level with flexible working bodies for partition structures on channels. To cite this article: *Mukaddas-Gaukhar* Kadirova. Tashkent Institute of Irrigation and Agricultural Mechanization Engineers, E3S Web of Conferences 365, 03007 (2023) *CONMECHYDRO – 2022* <https://doi.org/10.1051/e3sconf/202336503007>
 19. Kadirova M.-G.A. Autoregulator of water level for tray channels of parabolic section. //The journal "Hydraulic Engineering". No. 2/2022 (June-August) / Project of *The Media Group "Port News"*. ISSN 2227-8400. Science and Technology, pp. 26-31. [www.hydrotehr.ru/doi: 10.55326/22278400_2022_2_26](http://www.hydrotehr.ru/doi:10.55326/22278400_2022_2_26)
 20. Kadirova M.-G. A. Construction of a mobile dam to create a backup and automatic regulation of the water level on small rivers and watercourses in emergency situations. Proceedings of section No. 1 of the XXXII International Scientific and Practical Conference. Prevention. Salvation. Help. Khimki. Publishing house: Academy of Civil Protection of the Ministry of the Russian Federation for Civil Defense, Emergencies and Elimination of Consequences of Natural Disasters named after Lieutenant General D.I. Mikhailik (Khimki), 2022, pp: 49-53. ID: 48575635. (In Russian)
 21. Prokofev V.A., Sudolskii G.A. Hybrid modeling of hydrodynamics of spillway structures of hydroelectric power plants. Journal. Hydraulic engineering construction: Ministry of Energy of the Russian Federation PJSC "RusHydro". No. 8, 2021, pp. 60-66.
 22. Esin A.I. Mathematical simulation of operation of spillway works according to the scheme of water outflow from under the gate. //The journal "Prirodoobustroystvo". No. 5, 2011, pp.83-86. (In Russian)
 23. Mikhail Balzannikov. Studies of Structures of Gates in Hydraulic Engineering. 2019 IOP Conference Series: Materials Science and Engineering XXVIII R-P-S Seminar 2019 IOP Conf. Series: Materials Science and Engineering 661 (2019) 012056 IOP Publishing doi:10.1088/1757-899X/661/1/012056
 24. Kim, Y., Choi, G., Park, H., & Byeon, S. (2015). Hydraulic jump and energy dissipation with sluice gate. // Journal "Water (Switzerland)", 7(9), 5115–5133. <https://doi.org/10.3390/w7095115>