

PAPER • OPEN ACCESS

Fundamentals of developing and designing portable weirs for farmlands

To cite this article: Jamshid Choriev *et al* 2020 *IOP Conf. Ser.: Mater. Sci. Eng.* **869** 072023

View the [article online](#) for updates and enhancements.

You may also like

- [Isolation, Phenotypic and Molecular Characterization of the Oyster Mushroom *Pleurotus* spp. and Evaluation of Its Efficacy in Producing the Antibiotic Pleurotin](#)
Abdullah Abdulkareem Hassan and Maarib Ahmed Awad
- [The effect of surface mechanical attrition treatment \(SMAT\) on plastic deformation mechanisms and mechanical properties of austenitic stainless steel 316L](#)
Elham Rajabi, Reza Miresmaeili and Mahmood Aliofkhazraei
- [Feasibility Analysis on the Application of 3D Printing Technology on Municipal Roads](#)
Huang Jueru



245th ECS Meeting • May 26-30, 2024 • San Francisco, CA

[Learn more & submit!](#)

Present your work at the leading electrochemistry & solid-state science conference.

Network with academic, government, and industry influencers!

Submit abstracts by December 1, 2023



Fundamentals of developing and designing portable weirs for farmlands

Jamshid Choriev, Turavoy Muslimov, Ramz Abduraupov, Azat Khalimbetov and Sarvar Abdurakhmonov

Hydrotechnical Construction Department, Tashkent Institute of Irrigation and Agricultural Mechanization Engineers, Tashkent, 100000, Uzbekistan

E-mail: jamshidc77@gmail.com, muslimovtd@mail.ru, ramz_abduraupov@mail.ru, halimbetovazat@gmail.com, s.n.abduraxmonov@gmail.com

Abstract. The article reveals the fundamentals of engineering and designing mobile weir with rectangular opening for farmlands, applicable for measuring discharge in interfarm and temporary canals. It includes the fundamentals of choosing most efficient structural solutions for the weir, choosing material for fabrication of its main elements, performing the static design for weir horizontal beams according to marginal states of providing reliability and stability of weir main elements. Results of calculations of diameter of steel bar for rectangular weir with $B=25\text{cm}$ showed that the diameter needed is 6mm. The diameter is small enough for the weir to be called a thin plate weir. Thus, using 6mm bar is reasonable enough from the point of view of stability and the by the requirements for a thin plate weir.

1. Introduction

Nowadays the reforms in every sphere of Uzbekistan's economy are serving as building bricks for people's prosperity and providing necessary conditions for citizens to reveal their creative potential.

Step by step transition of the economy to market based policy and full denial of the old system which was based on administrative and command management is facilitating the provision of wide possibilities and good conditions for small businesses and private enterprises as well as farming business. [1,2]. As an example we can mention the organization of farmlands in the country and their transformation into multiple branch businesses. Nowadays 162 thousand farmers are operating in the country. Most of them are based on specialized in crop farming. The increase of the number of individual farmers has led to the increase of individual water users in agriculture. Therefore, there is a task for the government to fairly distribute water among users and provide water to each consumer according to their crop irrigation schedule. In certain cases, there have been practice to distribute water to farmers according to their land area. But it is very important to note that water to farmers must be allocated according to scheduled irrigation rate for specific crop and based on the soil conditions of the region where their farmland is located, type of the crops they grow, the ratio of lands where various types of crops are grown and other factors. Otherwise random allocation of water only based on farmers' total land area will lead to the decrease of crop yield and degradation of meliorative conditions of the land due to wrong watering amounts.

In order to solve this economically and socially important problem, it is important to provide each farmer with compact portable flow measuring weirs so that each farmer could use water reasonably and keep accurate calculation of the amount of water they use and save water resources by using



necessary amount of it. In order to give necessary amount of water to crops it is important to accurately measure it [3,4,16]. Nowadays the existing water measuring devices in irrigation system are mostly of stationary type. Besides, the capabilities of such stationary water measuring devices are limited when it comes to measure water continuously in small inner farm and temporary canals, which are built seasonally [5]. Advantages of using portable weir for small streams are discussed in authors previous works as well as in works by other authors [17].

2. Method

In order to solve the above mentioned problem staff of the department “Hydraulic Construction and Engineering Structures” of Tashkent Institute of Irrigation and Agricultural Mechanization Engineers have developed the design of a compact portable water measuring weirs [6,7,8,9,10]. These portable weirs are mostly intended for the use by farmers and their cost is 3 to 4 times cheaper than the stationary ones and, most importantly, their wide cover area, that is, they can be used to measure water in several fields during a day.

The given portable weirs have been designed with triangular, trapezoidal and rectangular openings and their structural design have been patented by the Bureau of Intellectual Property of Uzbekistan (patent №00647). The first samples of the weirs were tested in the laboratory and in the field, the laboratory and field experiments of the weir is shown in Figure 1.



Figure 1. Testing the portable water measuring weir in field and in laboratory.

The design of the portable water measuring weir is very simple, consisting of vertical and horizontal steel bars. The structure is covered with flexible water impermeable PVX material by inserting the steel bars in the pockets in the material. The structural scheme and the main elements of the portable weir with rectangular opening is illustrated in Figure 2.

In designing portable water measuring weirs it is important to choose right material and conduct static calculations for its each element based on the requirements set for control and measuring devices and according to applied design methods. Therefore, it is reasonable to choose corrosion resistant 09Г2С, 14Г2 and 15ХСНД grade steel for the main elements of the weir [11]. Operation accuracy of measuring weir and the reliability of the obtained results significantly depend on the static calculation of it. The particular attention must be given to correct determination of the amount of loads applied on the weir and how the loads are acting on the structure in order to conduct its static calculation. Schemes for most unfavorable conditions must be developed. Hydrostatic pressure of water at the headrace of the weir is the permanent load acting on the it. Imposed load on the weir would be the wind load in the region, which also must be considered. In order to simplify calculations, the own weight of weir elements can be neglected in calculations due to their insignificant impact, which can be considered through coefficients.

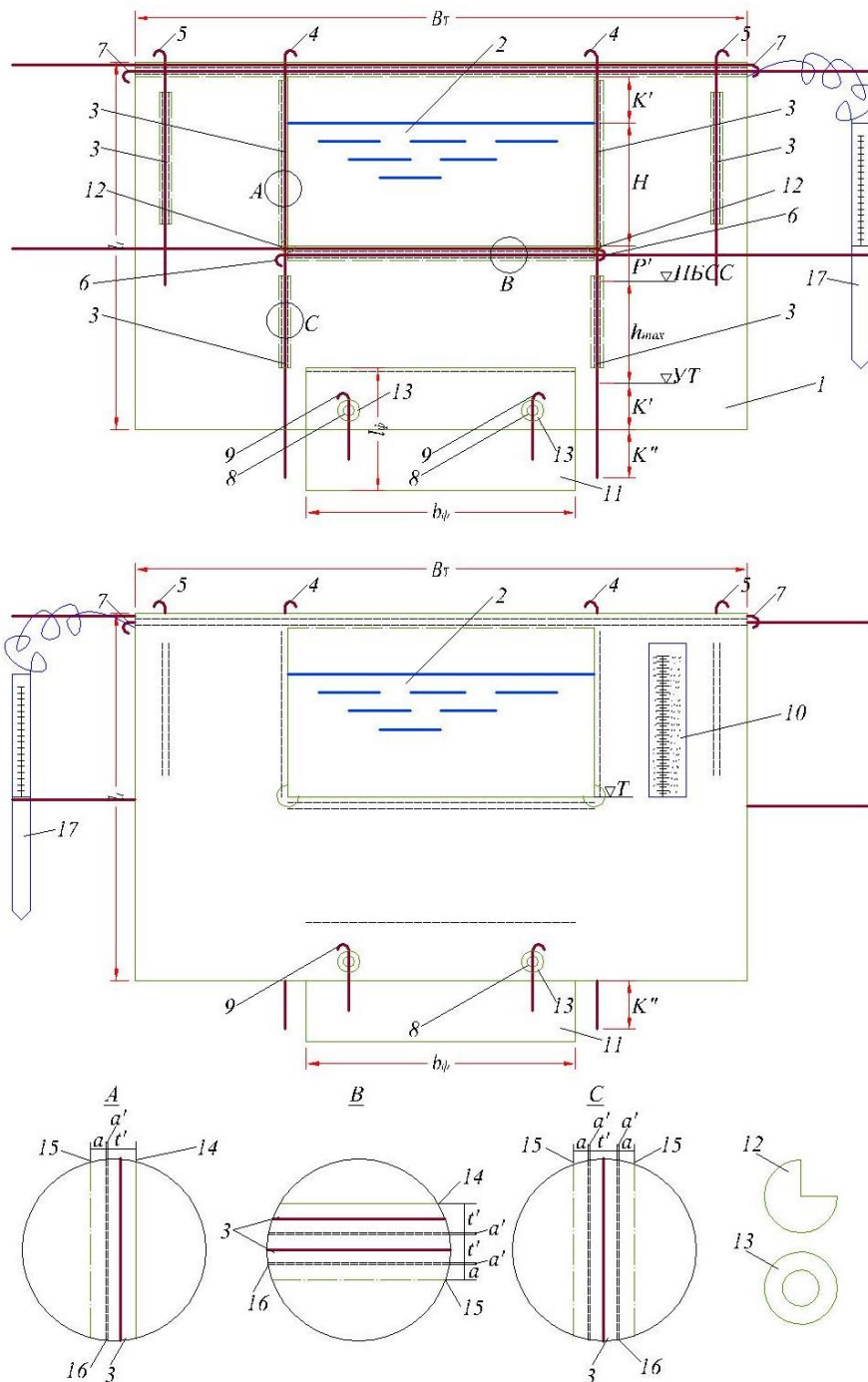

Figure 2. Structural composition of the portable weir with rectangular opening:
 1 – impermeable material; 2 – water flow opening; 3 – pockets for vertical and horizontal bars;
 4,5 – vertical steel bars; 6,7 – horizontal steel bars; 8 – openings for channel bottom fixation steel piles; 9 – bottom piles; 10 – measuring scale; 11 – tail race channel bottom scouring prevention apron;
 12 – angle strengthening patch; 13 – round patch; 14 – material bending line; 15 – material cutting line; 16 - seam.

The following initial dimensions are set before calculating the main elements for stability:

h_{max} – maximal flow depth in canal; B – bottom width of the weir opening;

B_c – top width of weir opening ($B=B_c$ for weir with rectangular opening);

H_T – height of weir opening;

$$H_T = H + K, \tag{1}$$

where: H – maximum height of water at weir opening above the bottom of the opening; K – reserve height of weir opening to pass floating debris, taken as $K \geq 100$ mm; P' – тешиқдан оқиб чиқаётган сув тагига ҳаво киришини таъминловчи захира баландлиги, куйидагича аниқланади:

$$P' = \nabla O_T - \nabla O_{\text{ИБСС}} \tag{2}$$

where: P' is usually taken $P' \approx 30...50$ мм қабул қилинади, ∇O_T - level of the bottom of weir opening; $\nabla O_{\text{ИБСС}}$ - water level at the channel tail race.

Based on the dimension set above, structural stand scheme for weir design is created (Fig.3).

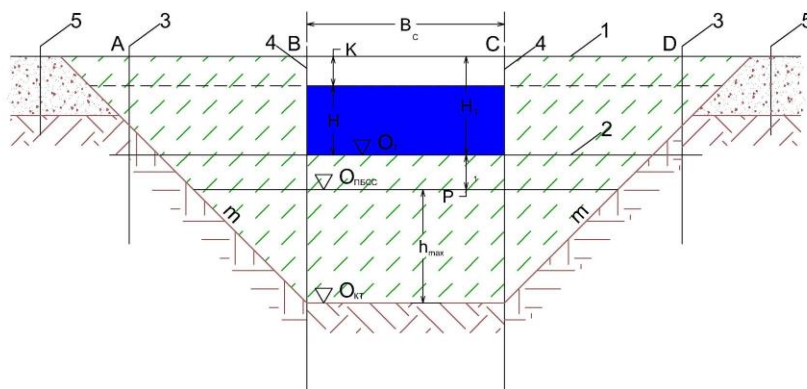

Figure 3. Structural stand scheme for weir with rectangular opening:
 1,2 – upper and lower horizontal bars;
 3,4 – vertical side bars and vertical main bars;
 5 – banquette pile bars;
 b_k – channel bottom width;
 m – channel side slope at the point of weir installation.

The structural stand in Fig.3 mainly consists of upper and lower horizontal bars, vertical side bars and vertical main bars. Water hydrostatic pressure acts on the horizontal bars through weir cover material and is passed to vertical stands, and statically the vertical bars are considered to be statically indeterminate beam with three spans. The main vertical bars and side bars are supports of these beams which are statically connected via roller support.

The following design scheme (Fig.4) is created for static calculation of horizontal bars and determine the loads acting on them.

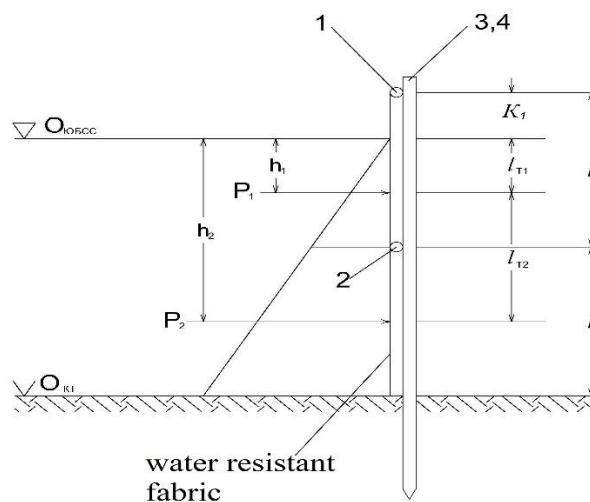

Figure 4. Scheme for determination the hydrostatic pressure acting on horizontal bars of the weir:
 1,2 – top and bottom beams; 3,4 – support vertical bars

3. Results

The vertical distance between horizontal bars are determined first.

$$l_1 = H + K, \quad (3)$$

$$l_2 = h_{\max} + P', \quad (4)$$

Hydrostatic pressure of water on the weir's particular elements is determined as follows:

$$P_i = \gamma_w \cdot h_i, \quad (5)$$

where: γ_w - specific weight of water, $\gamma_w = 10 \text{ kN/m}^3$; h_i - the depth of water above the point of interest on the weir.

For the scheme shown above in Fig.4:

$$h_1 = \frac{l_1 - K}{2}, \quad \text{and} \quad h_2 = (l_1 - K) + \frac{l_2}{2}, \quad (6)$$

The load from hydrostatic pressure on the beams of the weir is determined as follows [5].

$$P_{Ti} = \frac{P_i}{2}, \quad P_{Ti+1} = \frac{P_i}{2} + \frac{P_{i+1}}{2}, \quad (7)$$

Load from hydrostatic pressure is passed to each beam as distributed force:

$$q_{Ti} = P_{Ti} \cdot l_{Ti}, \quad (8)$$

where: P_{Ti} - hydrostatic pressure of water on the beam being designed; l_{Ti} - loaded span of the beam being designed.

$$h_{T1} = \frac{l_1 - K}{2}, \quad h_{T2} = \frac{(l_1 - K)}{2} + \frac{l_2}{2}, \quad (9)$$

Top and bottom bars design scheme is taken as continuous three span beams, so they are calculated as three span statically indeterminate beams, loaded with distributed load q_{Ti} . The distance between supports is l_m , which is also the width of the opening for weir with rectangular opening, i.e. $l_m = B_c$. Upper horizontal bar design scheme and bending moment diagram for it is illustrated in Fig. 5.

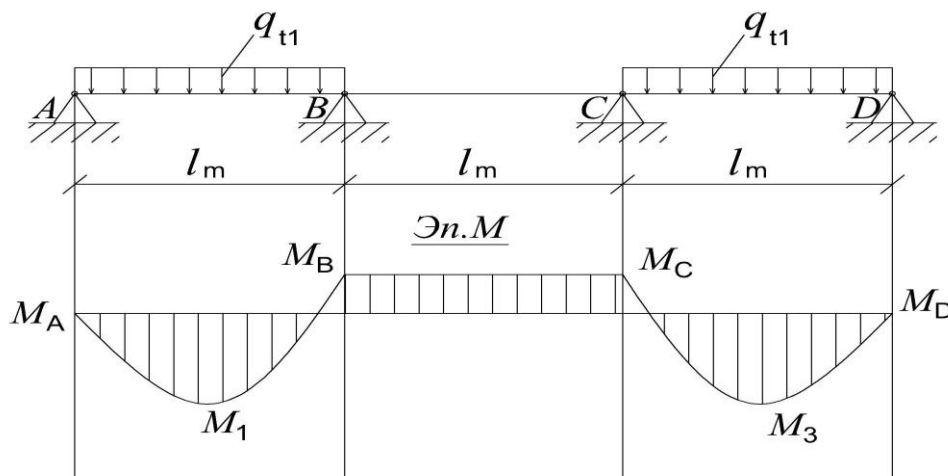

Figure 5. Upper horizontal beam design scheme and bending moment diagram

Bending moment values for the top beam design scheme is determined as follows according to construction mechanics rules [12,13]:

$$\left. \begin{aligned} M_A = M_D = 0 \\ M_1 = M_3 = 0,101 \cdot q_{T1} \cdot l_m^2 \\ M_2 = -0,05 \cdot q_{T1} \cdot l_m^2 \\ M_B = M_C = -0,05 \cdot q_{T1} \cdot l_m^2 \end{aligned} \right\}, \quad (10)$$

Bottom horizontal bar design scheme and bending moment diagram for it is illustrated in Fig. 6.

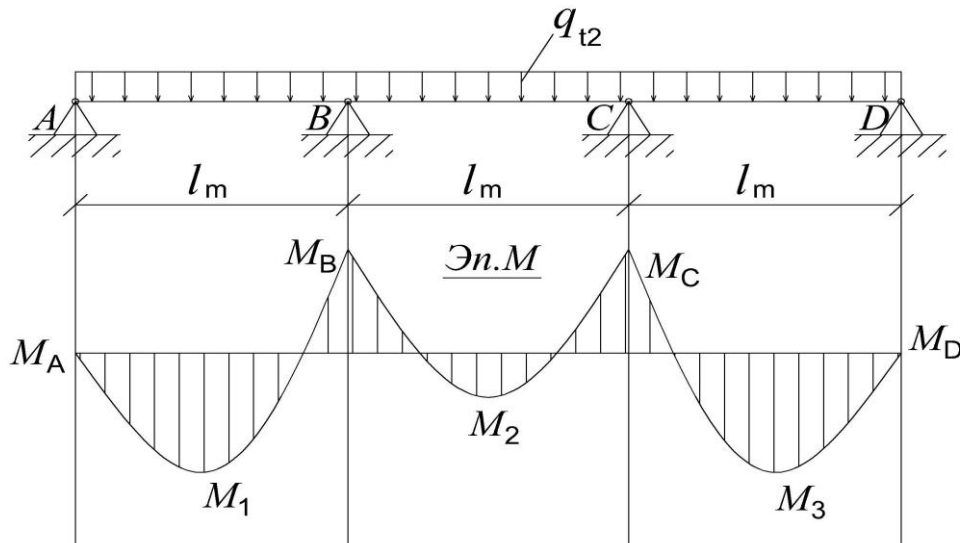

Figure 6. Bottom horizontal beam design scheme and bending moment diagram.

Beam bending moment values for statically indeterminate beam is determined as follows:

$$\left. \begin{aligned} M_A = M_D = 0 \\ M_1 = M_3 = 0,08 \cdot q_{T2} \cdot l_m^2 \\ M_2 = 0,025 \cdot q_{T2} \cdot l_m^2 \\ M_B = M_C = -0,107 \cdot q_{T2} \cdot l_m^2 \end{aligned} \right\}, \quad (11)$$

For the reasons of unification of the beam sizes based on the above mentioned calculations, the maximum bending moment is determined, $M_{\max} = M_B$ and then required moment of resistance is determined according to strength requirements by the first group of boundary conditions as follows:

$$W_T = \frac{M_{\max} \cdot K_1}{R_{y(u)}}, \quad (12)$$

where: K_1 - safety factor (reserve coefficient); $R_{y(u)}$ - bending resistance of the beam material.

Beam cross sectional dimensions are determined based on calculated moment of resistance. In doing so, hydrostatic pressure which is passed to the beam through weir cover material must be taken into consideration, and based on it, the cross section of the beam is taken symmetric, i.e. round shaped.

For the round cross section shape of the beam, the required diameter is calculated as follows:

$$D = \sqrt[3]{\frac{32 \cdot W_T}{\pi}}, \quad (13)$$

In order to decrease the weight of the weir, the cross section of the beam can be taken in the shape of a ring, i.e. hollow shaped.

If ring shaped cross section is chosen for the beam and taken the ratio of the inner and outer diameter of the cross section would be $\alpha=d/D$, then the inner diameter will be $d=\alpha D$.

Thus, the outer diameter of the cross section will be determined as follows:

$$D = \sqrt[3]{\frac{32 \cdot W_r}{\pi(1-\alpha)}}, \quad (14)$$

And the inner diameter:

$$d = \alpha \cdot D, \quad (15)$$

Based on the determined values the strength of the weir beams by the first group of boundary conditions is checked as follows:

$$\sigma = \frac{M_{\max} \cdot K_1}{W} \leq R_{y(u)} \cdot \gamma_c, \quad (16)$$

where: M_{\max} - maximum value of bending moment on the beam being designed; K_1 - safety factor, $K_1 = 1.1$; W - real moment of resistance of the beam being designed, which is determined as follows for bar with ring shaped cross section:

$$W = \frac{\pi(D^3 - d^3)}{32}, \quad (17)$$

γ_c - service factor, $\gamma_c \leq 1$.

The weir is also checked for normally operability by the second group of boundary conditions [14] as follows:

$$\frac{f}{l} = \frac{q_{Ti}^n \cdot l_m^3}{313 \cdot E \cdot J} \leq \left[\frac{f}{l} \right], \quad (18)$$

where: $\frac{f}{l}$ - relative deformation of the beam; q_{Ti}^n - normative value of the load acting on the beam being designed; l_m - span distance between supports; E - modulus of deformation of the beam material;

J - moment of inertia of the beam cross section; $\left[\frac{f}{l} \right]$ - allowable relative deformation of the beam to

provide normal operation, $\left[\frac{f}{l} \right] = \frac{1}{200}$.

4. Discussion

In designing water measuring weir the loads acting on it and their values are taken based on normative documents. The static design accuracy of weir's structural elements can notably affect the results taken from the use of weirs. Therefore, the reliable operation of water measurement will be provided if the results obtained by above recommended schemes and design procedure are controlled by testing procedures [15]. When the beam was calculated for portable weir with rectangular opening with width $B=25$ cm with these method, it came up to be 6mm. It is small enough for portable weir to be considered a thin plated weir. Therefore, 6 mm steel rod can be used for portable weir with 25 cm wide rectangular opening. Research results on flow measurement accuracy of these portable weirs and their comparison to stationary ones are discussed in authors' previous articles, published in journals and conference proceedings [6,7,8,9,10]. Procedures of using portable weirs are the same as the for stationary ones and other fully metallic type portable thin plated weirs [18].

5. Conclusions

It is of a great importance for the farmers to be provided with low cost water measurement weirs to have the water resource be used rationally and in some cases to prevent water to be used wastefully. The above mentioned portable water measurement weirs is a control measurement instrumentation by its designation. Therefore, it is important for these type of portable water measuring weirs to use right type of materials, and most optimal structural solutions based on strength and stability requirements. Thus, it is reasonable to consider hydrostatic pressure of water as the main load in designing the weir structure and using strengthened corrosion resistant 09Г2С, 14Г2 and 15ХСНД grade steel for the main elements, which are horizontal upper and lower rods, vertical support rods. Reasonable results will be obtained if the static design of the weir beams is done with above recommended relationships by the first group of boundary conditions. Thus the basis will be set for reliable operation of the weir by providing its strength and stability. When the beam was calculated for portable weir with rectangular opening with width $B=25$ cm with these method, it came up to be 6mm, which is small enough for the portable weir to be considered small plated type, that means 6 mm steel rod can be used for portable weir with 25 cm wide rectangular opening.

References

- [1] The Decree of the President of the Republic of Uzbekistan PF-5418 dated April 17, 2018 [On the measures of organizing the activity of the Ministry of Water Management of the Republic of Uzbekistan]. (In Uzbek)
- [2] Khamraev Sh Umurzakov U Salokhiddinov A Sultonov T 2017 Close link between water, peace and safety issues *J Irrigation and Melioration* Tashkent pp. 3-10.
- [3] Haan C T 1994 Design hydrology for small catchments (San Diego) p 588.
- [4] Novak P 2007 Hydraulic structures (London) p 700.
- [5] Khamraev Sh R 2009 The role of water user's association in intensification of agricultural reforms (Tashkent) p 295.
- [6] Bakiev M Kirillova E Choriev J 2011 Portable weirs for farmlands (Tashkent, Manual) p 26.
- [7] Bakiev M Choriev J 2016 Portable weir design with rectangular opening and methods for determining its dimensions *J Irrigation and Melioration* №4(6). pp. 36-38.
- [8] Choriev J Bakiev M 2016 Mobile water measuring weir with rectangular opening for farmlands. *J European Science Review* pp. 228-230.
- [9] Choriev J 2016 Portable weir with trapezoidal opening for farmlands *Puti povysheniya effektivnosti oroshaemogo zemledeliya* (Scientific conference proceedigs). №3 (63) pp. 201-206.
- [10] Bakiev M Choriev J 2017 New design for portable weir with triangular opening for farmlands *J Fargona politehnika institute ilmiy texnika jurnali* Volume 21, № 3. pp. 31-36.
- [11] Mel'nikov N 1998 Steel structures Designer's manual. (Moscow) p. 512.
- [12] Mirsaidov M Matkarimov P Godovannikov A 2010 Strength of materials (Tashkent) p. 410.
- [13] Kleyn G 1980 Manual for practical classes in construction mechanics course (Moscow) p. 92.
- [14] Bakiyev M Muslimov T 2013 Engineering structures (Tashkent) p. 215.
- [15] Novgorodskiy M 1971 Testing of materials, products and structures (Moscow) p. 326.
- [16] Runtz S 1982 Measurement and computation of streamflow: Volume 1. Measurement of stage and discharge *Geological survey water-supply paper* (US government printing office) p. 284
- [17] Moore P 1975 Measuring flow of small streams: Use of a portable weir. Tane 21 (<http://www.thebookshelf.auckland.ac.nz/docs/Tane/Tane-21/22%20Measuring%20Flow%20of%20Small%20Streams.pdf>)
- [18] Water measurement manual 2001 A water resources technical publication USDI Bureau of Reclamation (US Gov Printing office, Washington) p. 317.