

PAPER • OPEN ACCESS

Study on application of electrohydraulic effect for disinfection and increase of water nutrient content for plants

To cite this article: A Turdiboyev *et al* 2023 *IOP Conf. Ser.: Earth Environ. Sci.* **1142** 012027

View the [article online](#) for updates and enhancements.

You may also like

- [Recent advances in electrohydrodynamic pumps operated by ionic winds: a review](#)
Michael J Johnson and David B Go
- [Fine-resolution patterning of copper nanoparticles through electrohydrodynamic jet printing](#)
Khalid Rahman, Arshad Khan, Nauman Malik Muhammad *et al.*
- [Numerical simulation and PIV experimental analysis of electrohydrodynamic plumes induced by a blade electrode](#)
Ph Traoré, M Daaboul and Ch Louste



ECS The Electrochemical Society
Advancing solid state & electrochemical science & technology

243rd Meeting with SOFC-XVIII

Boston, MA • May 28 – June 2, 2023

Accelerate scientific discovery!

Learn More & Register

Study on application of electrohydraulic effect for disinfection and increase of water nutrient content for plants

A Turdiboyev¹, N Aytbaev¹, M Mamutov², A Tursunov³, T Toshev⁴, and N Kurbonov⁴

¹“Tashkent Institute of Irrigation and Agricultural Mechanization Engineers” National Research University, 100000 Tashkent, Uzbekistan

²Karakalpak State University named after Berdakh, 230112 Nukus, Republic of Karakalpagistan, Uzbekistan

³Tashkent State Agricultural University, 100020 Tashkent, Uzbekistan

⁴Department of Electrical Engineering, Karshi Engineering and Economics Institute, 180100 Karshi, Uzbekistan

*Email: turdibojev1983@mail.ru

Abstract. This article describes the application of electrohydraulic effect to decontaminate wastewater and increase nutrient content in water for agricultural crops. It is characterized by the formation of chemical processes in water and electrohydraulic effect carried out using ultrasound and ultraviolet radiation. The nutrient content in water has increased from 1.1 mg/l to 2.23 mg/l, i.e. it has gone up by 102.7% after the preliminary water treatment by means of the electrohydraulic effect, while neutralization of coliform bacteria in the treated water has decreased from 3474 (RLU) to 610 (RLU), i.e. it has dropped to 82.55 over control. The increase of nutrient chemicals in water and coliform bacteria neutralization (*Escherichia coli*) depend on the treatment time, discharge voltage, capacitor capacity, discharge interval and the number of pulses if treated with electrohydraulic effect conducted by means of ultrasound and ultraviolet radiation causing a chemical reaction of electrohydraulic shock in water. The discharge voltage for increase is 9-15 kV, disinfection time - 100-120 minutes depending on the voltage of treatment. It is advisable to have the capacitor capacity of 0.8 μ F and discharge interval of 10-12 mm.

1. Introduction

Human needs for food and agricultural products have been increasing year after year due to the significant growth of the world's population, intensive industrial development, environmental deterioration as a result of the global climate change and limited land and water resources. Thus, the rational land use and yield enhancement by improving land reclamation and its productivity is one of the urgent tasks [1].

The role and significance of the agricultural sector in ensuring the national food security on a global scale has been increasing day by day [2]. Particularly, in our country, providing population with the guaranteed agricultural products, further increase in productivity and concernment, introducing scientific developments and modern approaches to the field through the available resources and opportunities are the most critical issues.



Esteemed President Shavkat Mirziyoev, in his address to the Oliy Majlis on December 29, 2020, specifically emphasized that the factor giving the fastest results in reducing poverty and increasing incomes of rural population is rapid growth in agricultural productiveness and efficiency.

Nitrogen combined with oxygen (NO_3) or hydrogen (H_4^+) is required for the favourable plant growth. The compound of oxygen and nitrogen is called nitrate. The compound of hydrogen and nitrogen is ammonium. Nitrate nitrogen is contained in all types of soil, but plants have need of ammonium nitrogen. That particular ammonium nitrogen is lacking in the soil. The plant is forced to feed on nitrate nitrogen, converting it into an assimilable form. [3]

Nitrates serve as building blocks for plants. The normal plant growth and its activity cannot be imagined without the optimal supply of micro and macro elements. Nitrates are involved in all stages of a plant life, from seeding to harvesting. The development of cells and a whole organism cannot occur without nitrates. Therefore, the technique for nitrate content increase in water used for plant irrigation applying electrohydraulic effect and along with that water disinfection method are proposed [4].

Nowadays, a variety of wastewater treatment methods are being implemented and harnessed. But these methods do not always give the expected results. Chemical methods can be used to control bacterial and viral diseases in wastewater. However, the introduction of biocidal and disinfecting substances into the nutrient solution might lead to a decrease in the ecological quality of a processed product. Water ozonation technologies are an alternative and more environmentally friendly methods. The implementation of water ozonation requires additional resources and energy, which might increase the risk of environmental damage. Ozone is capable of inactivating microorganisms in water, but it takes longer to be treated due to the rapid ozone decomposition at high temperatures and acidic water [5]. The high ozone concentration in water may have a negative effect on the root system of plants. Water disinfection with the aid of ultraviolet (UV) light is the most effective way to eliminate bacterial microbes [6]. When there is a large amount of mechanical impurities in the wastewater, the quality of disinfection with ultraviolet light decreases, the technology requires installation of additional filters to clean nutrient solutions. Due to energy costs and maintenance costs, the UV water treatment is more expensive than other methods [7]. One of them poses a great ecological threat to the environment, the other is not reliable enough in terms of neutralization, and the other is economically very expensive. For this reason, the development of technologies suitable for the structural composition of waters in our country, their quality indicators and extent and operation of facilities and their convenience in use is a significant problem of today [8].

2. Methods

The electrohydraulic effect technology is characterized by low energy consumption, quick treatment time, ease of process implementation, high potential for available water neutralization compared to technological equipment [9,10]. It is appropriate to use electrohydraulic effect technologies in all areas of agricultural production. The use of electrohydraulic effect technology for technological processes implementation into agricultural complexes does not cause changes at the gene level and does not have a negative impact on the environment and people [11].

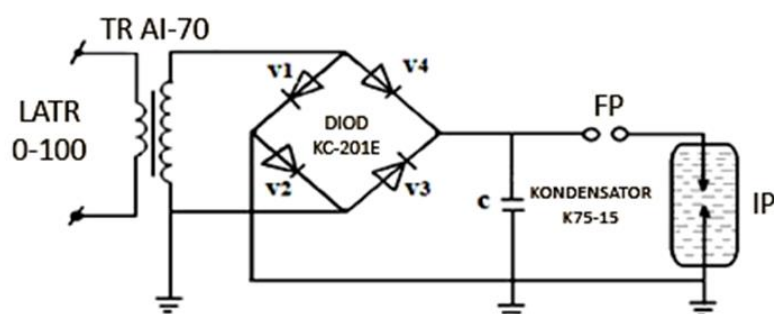

Figure 1. Principle electrical diagram of the electrohydraulic water treatment device

The circuit includes a laboratory autotransformer, a step-up AI-70 transformer, KS-201E high-voltage diodes, a K75-15 high-voltage capacitor battery, and an FP-discharge gap for voltage adjustment (see Figure 1).

The essence of the electrohydraulic effect is the creation of extremely high pressure in water at the expense of electric charge [12]. Impulse discharge occurs in microseconds, pulse power reaches 100 kV, which causes hydraulic pressure formation. At the same time, the process of element ionization, X-ray and ultraviolet radiation are carried out. These factors have different chemical effects on the liquid and its substances. The electrohydraulic effect occurs by converting electrical energy into mechanical energy, due to the electrical discharge generation. There are three stages of discharge generation, the sparking discharge, the increase in discharge energy and the final stages.

3. Analysis Findings and Examples

The essential problem of the agricultural crop irrigation is to form a nutrient solution with certain parameters. Chemical elements are dissolved in water, they participate in plant nutrition due to their absorption through the root system. Depending on the stage of plant growth, different nutrients are required, but for this, it is necessary to take into account the nitrate amount in water.

Based on the studies, three technological modes of electrohydraulic effect on water have been selected (Table 1).

Table 1. Technological modes of electrohydraulic effect on water

Parametres	I	II	III
Discharge voltage, kV	9	12	15
Capacitor capacity, mF	0.8	0.8	0.8
Inductance, mkGn	1.6	1.6	1.6
Discharge interval, mm	8	10	12
Working distance between electrodes, mm	7	9	11

Three selected modes: discharge voltage of 9, 12, 15 kV, air gap -8, 10, 12 mm, working distance between electrodes - 7, 9, 11 mm. One liter of wastewater has been treated in Midor. In the experiments, the dependence of the processing power on the number of nitrates in the water has been tested and the result is shown in Figure 2.

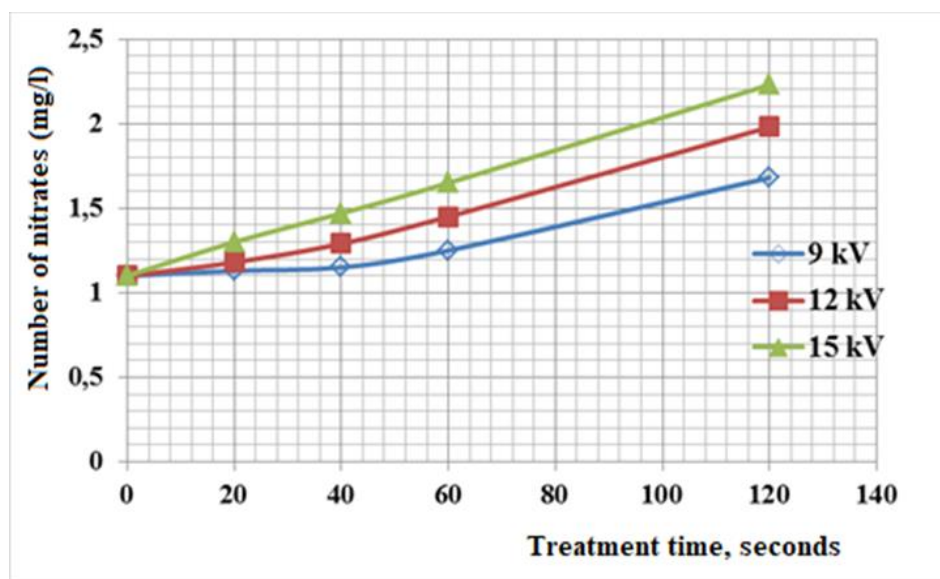

Figure 2. Dynamic pattern of the nitrate amount in the treated water at discharge voltages of 9, 12, 15 kV depending on treatment time

From the obtained experimental results, it can be concluded that not only increasing the discharge voltage increase can have a significant effect on the number of nitrates in water. The increase in the number of nitrates in water also depends on the treatment time. In this case, the discharge gap in air and the working gap between the electrodes should be changed according to the discharge voltage to be treated.

Electrohydraulic effect occurs in water combined with ultrasound and ultraviolet radiation. These effects serve to eliminate bacteria in water. It was determined that the bacterial disruption in water depends on the voltage value and treatment time (Figure 3).

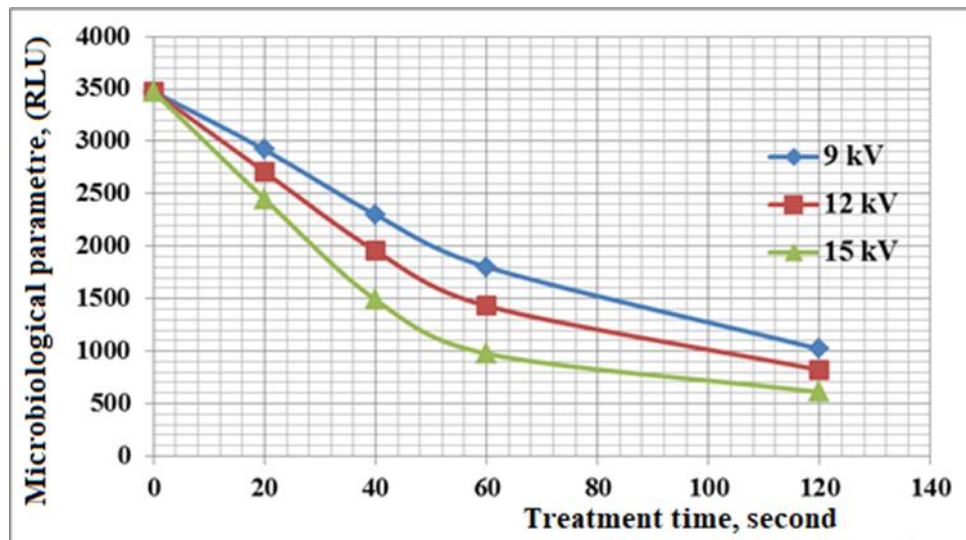

Figure 3. Dynamic pattern of microbiological parametres depending on discharge voltage and treatment time

In the experiments, it was checked to what extent *E. Coil* (intestinal bacilli) bacteria in the water had been neutralized. Based on the obtained experimental results, it can be said that the coliform bacterial disruption in water depends on the treatment time and the discharge voltage value. The higher the discharge voltage, the higher ultrasound and ultraviolet radiation.

The results of the experiment were tested in the laboratory of the Tashkent water supply company. A pH meter and an ionometer were used to measure nitrates according to the procedure for measuring nitrates in water.

4. Conclusions

As a result of the study of the wastewater treatment effectiveness used for watering plants with the electrohydraulic effect technology, it was found that in water, the electrohydraulic effect uses a strong electromagnetic field, strong discharge light, ultraviolet, X-ray radiation, ultrasound, and high-pressure mechanical energy to cause various physical and chemical effects on liquid and its substances. The possibility of chemical action exists.

The amount of nitrates in water is reduced from 2.23 mg/l to 1.1 mg/l by means of electrohydraulic treatment, i.e. it has increased to 102.7%, the possibility of additional plant nutrition has been developed. Disinfection of the coliform bacteria in wastewater from 3474 (RLU) to 610 (RLU), i.e. it has dropped to 82.55 over control, can prevent the transfer of *E. coli* bacteria to human and animal bodies through plants, and as a result, human health is preserved.

The following parameters as the discharge voltage equal to 9-15 kV, treatment time -100-120 minutes, capacitor capacity -0.8 μ F, discharge interval -10-12 mm depending on the treatment voltage conducted in combination with ultrasound and ultraviolet radiation, which causes a chemical reaction of electrohydraulic shock in water are recommended.

References

- [1] Belokopytov AV et al. 2022 A V Belokopytov et al 2022 IOP Conf. Ser.: Earth Environ. Sci. 979 012022 *IOP Conf. Ser.: Earth Environ. Sci.* **979** 012022.
- [2] Giller KE, Delaune T, Silva JV et al. 2021 The future of farming: Who will produce our food? *Food Sec.* **13** 1073–1099.
- [3] Aytbaev NA, Hoshimov FA, Bakhadirov II, Kurbanbayeva MS 2020 Development of Specific Standards of Energy Consumption by Types of Produced Products of the Spinning Product *E3S Web of Conferences* **216** 01169.
- [4] Turdiboyev A, Akbarov D 2020 The new production of electrotechnology cottonseed oil and energy *IOP Conf. Series: Materials Science and Engineering* **883** 012115.
- [5] Berdishev A, Djumaboyeva Z 2020 Evaluation of the effectiveness of electromagnetic treatment of well water *E3S Web of Conferences* **209** 07016.
- [6] Bayzakov T, Yunusov R, Yusupov Sh, Qilichev Z, Khasanova Yu 2021 Methods of using ecological sources of clean energy in the cultivation of bell pepper seedlings *IOP Conference Series: Science on Earth and the Environment* **939** 012007.
- [7] Ibragimov M, Turdiboyev A 2020 Justification of parameters of electric activator applicable to reduce mineralization of collector-drainage water *IOP Conf. Series: Materials Science and Engineering* **883** 012115.
- [8] Turdiboyev A, Akbarov D 2020 The new production of electrotechnology cottonseed oil and energy *IOP Conf. Series: Materials Science and Engineering* **883** 012115.
- [9] Yunusov R, Imomnazarov A, Mirnigmatov B, Ozodov E, Abduganiyev A, Nazarov O 2019 Modelling of liner electro drive in the watergate of hydrotechnical constructions *Journal of Physics: Conference Series* **1399** 044104.
- [10] Bayzakov T, Yunusov R, Bozorov E, Yusupov Sh 2020 Electrotechnological treatment against diseases found in almond trees grown in arid lands *IOP Conference Series: Materials Science and Engineering* **883** 012154.
- [11] Berdishev A, Eshpulatov N, Matchonov O, Yusupov SH 2020 Methodology for conducting an optimization experiment for harvesting dry short-stalked grain crops *IOP Conf. Ser.: Earth Environ. Sci.* **614** 012118.
- [12] Berdishev AS, Markaev NM, Hasanov J 2021 *E3S Web of Conferences* **264** 04090.