

Technology and Technical Equipment Ensuring a Sustainable Profile and Design Slope for Waterfurnishing

Bakhtiyar Matyakubov, Adiljan Atajanov, Davronbek Yulchiyev

Abstract: The article is devoted to the issues of water conservation and efficient use of water resources by improving the existing methods of irrigation through the furrows and the creation of new technical means ensuring the rational use of water and land resources during furrow irrigation, contributing to irrigation water savings. The proposed technology based on the fact that this measure is achieved by presenting changes and the automation of the working bodies of agricultural machinery involved in land reclamation measures, in particular, a furrow cutter and a bottom compactor. The technology allows for the production of agricultural industrial crops to use automated control of the working body when cutting furrows, to save water on irrigated areas and to achieve high yields due to the sustainable development of crops, and the proposed technical tool relates to agricultural machinery, especially a tool for caring of row crops, irrigated crops, the purpose of the invention, which is the creation of uneven compaction soil in the furrow bed along its length, with a change in soil density from the maximum value at the beginning and the minimum at the end, according to the irrigation method. The proposed technical tool is used for the device of uneven soil compaction in the furrow bed along the entire length, with a smooth change in soil density from maximum at the beginning and minimum at the end.

The proposed technology and technical means provide:

- increasing the efficiency of the use of water resources by creating a sustainable profile and design slope of the furrow saves irrigation water in the range of 10-12%;

- water saving and energy saving by creating a stable profile and slope of the furrow of the irrigated field, providing high uniformity of moistening of the root layer of the soil along the entire length of the furrows, especially when cutting them, new laser technologies and highly efficient trailed technical means and production methods were used, providing material savings of 6- 8%.

Keywords: furrow, slope, technology, irrigation technique, technical means, water resources, fertile watering, irrigation, water charging, planning, root-occupied layer.

I. INTRODUCTION

The main wealth of the people and the source of life is water. In order to avoid inefficient water losses, anti-filtering measures are carried out on all types of irrigation canals and their hydraulic structures are being repaired. In order to

Revised Manuscript Received on December 05, 2019.

* Correspondence Author

Bakhtiyar Matyakubov*, Department of Irrigation and Melioration, Tashkent Institute of Irrigation and Agricultural Mechanization Engineers (TIAME), Tashkent, Uzbekistan. Email: bmatyakubov@inbox.ru

Adiljan Atajanov, senior teacher of the department "Mechanization of irrigation and drainage works", TIAME. Email: adiljanatajanov@mail.ru

Davronbek Yulchiyev, assistant of the department "Irrigation and land reclamation", TIAME. Email: d.yulchiev86@mail.ru

increase and improve the efficiency of these facilities, the State Unitary Enterprise specializing in land reclamation and water management has been created and is operating. Accepted legal norms and privileges are crucial.

An important factor in increasing the effectiveness of these measures is the Decree of the President of the Republic of Uzbekistan "On the State Program for the Development of Irrigation and Improvement of Irrigated Lands on Irrigated Lands for 2018-2019" No. UP-3405 of November 27, 2017 [1].

As a result of the implementation of these decrees and decisions, the groundwater level on more than 260 thousand hectares of irrigated land was brought to optimal levels, on average, saline and severe salinity were reduced by about 32 thousand hectares, and the reclamation condition of 182 thousand hectares of irrigated land improved.

Efficient use of water resources is one of the urgent problems facing farmers who are consumers of water. Therefore, it is advisable to create, improve existing and introduce new modern techniques and technologies to save water resources and their effective use.

When conducting research on the selected topic, it was provided:

- selection and justification of experimental sites using the properties of soil, climate and types of crops;
- orientation of the composition and field experimental research programs for monitoring the monitoring of all processes;
- the formation of agricultural and technical requirements for the furrow forming unit with an automated control system
- substantiation of compliance of design parameters of irrigation furrows, cut on the basis of the proposed technology, with the stages of development of agricultural industrial crops;
- quality of irrigation, crop yields, assessment of the effectiveness (observation) of monitoring the efficiency of the irrigation regime and annual irrigation equipment;
- study and justification of the conditions for the use of technical means of the automatic control system for working equipment.

II. MATERIALS AND METHODS

One of the important agricultural operations in agricultural production is the layout of the irrigated area. Despite the fact that the surface of the irrigated area is uneven, the design slope of the bottom of the cut furrow provides the following opportunities: significantly improve the quality of irrigation

Technology and Technical Equipment Ensuring a Sustainable Profile and Design Slope for Waterfurnishing

of crops and leaching of saline soils; increase productivity during irrigation; normalizes the use of irrigated areas, irrigation water and natural rainfall; increases the efficiency of fertilizers. All this as a result will lead to an increase in crop yields by 1.5-2.2 times and will reduce the cost of production

In the current technology, after processing the soil, furrows are cut relative to the prepared surface of the irrigated area, and the longitudinal profile of the bottom of the furrow and its slope are not obtained for the smooth and uniform flow of irrigation water that hydraulics require. In practice, this situation occurs and is confirmed in research conducted by us. The study shows that the longitudinal profile of the bottom of the cut furrows is characterized by large deviations, even with high accuracy of the planned surface of the irrigated area.

When planning, all this requires a lot of labor during irrigation and does not ensure uniform soil moisture both in the thickness of the root layer of the culture and in the length of the cut furrow. At the beginning of the chopped furrow, from where irrigation water is supplied, the maximum moisture depth is obtained, and at the end of the furrow it reaches a minimum value. It is possible to equalize soil moisture to the maximum value, but this is achieved due to a significant increase in the overhead of irrigation water and the time of irrigation of crops.

The main goal of ensuring continuity over the field surface of the projected slope of the chopped furrow in irrigated lands is to eliminate irregularities that impede irrigation and mechanized agro technical measures during the cutting of furrows (in loosened soils), as well as the main factor is the efficient use of water, uniform distribution of water over the area and furrows ensuring uniform soil moisture. This contributes to the uniform development of crops, which ultimately creates the conditions for a high yield

Even with a normal layout of the surface of the irrigated field, a variable soil density of the bottom of the furrows and a uniform distribution of moisture along the depth and length of the root layer of the soil are not provided. Uneven soil compaction of the bottom of the furrows (at the beginning of the furrows is dense, at the end there is no density) and the continuity of the slope along the furrows (due to automatic control) makes it possible to eliminate the uneven moisture of the root layer of the soil.

III. RESULTS AND DISCUSSION

Field observations were carried out on the irrigated lands of farms of the Khorezm region of the Republic of Uzbekistan (p/f “Ergash Ruzimov”, “Odilbek Ishchanov”, “Tulkin-Mirzabek-Asilbek”) and the Republic of Karakalpakstan (p/f “Reimbay boshlik”).

On the fields of these farms there are collector-drainage networks, irrigation networks have engineering structures. Irrigation water is delivered for irrigation of crops with large irrigation canals and temporary irrigation, irrigation is carried out by furrows. Soils on the fields of farms are weakly and highly saline.

The following observations and studies were carried out on cotton experimental fields:

- in order to study the soil conditions of the experimental plots before sowing cotton seeds to the depth of groundwater, the

soil was studied in layers; soil samples were obtained in the genetic layers of the section and in laboratory conditions, the mechanical composition of the soil, humus, nitrogen, phosphorus and potassium, as well as salts in the soil composition were determined;

- the volumetric weight of the soil of the experimental plot was determined at the beginning of the growing season and at the end in layers of 0-100 cm at a height of 10 cm using steel cylinders;

- Water permeability of the soil of the experimental plot at the beginning of the growing season and at the end using a cylindrical circle according to the method of Nesterov was determined;

- LFMC (limited field moisture capacity) was determined according to the Rozov method (a site 2 x 2 m in size is filled with water with a volume of 2000-3000 m³ in layers of 0-100 cm at a height of 10 cm);

- observation wells were installed to study the groundwater level of the experimental site and the degree of mineralization, water samples were taken and its level was monitored, the composition and amount of salts were studied using a conductivity meter;

- determined the change in moisture in the experimental plot at the beginning of the growing season and at the end using a digital moisture meter;

- water consumption at the experimental site is determined by the Thomson water-measuring device (90) and according to the table by calculation

- the degree of soil salinity of the experimental plot at the beginning of the growing season and at the end with the help of a digital hygrometer device was determined in layers 0-100 cm at a height of 10 cm;

- the growth and development of cotton grown in experimental fields was carried out in accordance with the methodology adopted by the Research Institute of Cotton Breeding, agricultural technology of seed production;

- the thickness of the cotton is determined only after thinning and at the end of the growing season;

- cotton growth on June 1 and the number of sheets;

- cotton growth, the number of branches and flowers from July 1;

- cotton growth, the number of branches and a cotton box on August 1;

- cotton growth on September 1, the number of boxes and the number of opened boxes;

- the weight of cotton wool on one box and the yield of cotton were calculated from the number of options and calculation series.

As a result of planning irregularities in the surface of the irrigated area with tolerances up to $\pm 2 \dots 3$ cm, accuracy gives an increase in yield and can significantly bring profit, covering the cost of irrigation. The purpose of the study was not to ensure accurate laser alignment of the irrigated field surface along the furrows, but to focus on ensuring the continuity of the slope of the bottom of the furrows and the development of agrotechnical requirements for creating a technical tool [2].

The annual operational planning of irrigated land requires a large amount of earthwork and material costs. From the point of view of economy, the aim of the study is the use of cheap technology, which ensures the quality of moistening along the length and depth of the furrows with a continuous slope, along the length and with a variable bottom density of the cut furrows. This is achieved by introducing changes and automation of the working bodies of agricultural machinery involved in land reclamation measures, in particular, a furrow cutter and a bottom compactor (Fig. 1) [3]

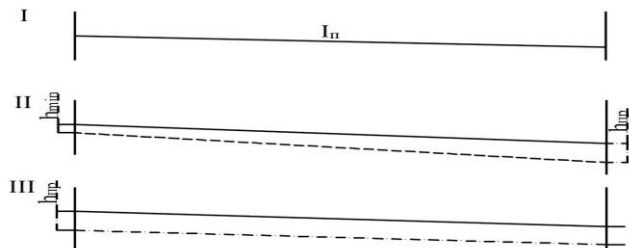

Figure 1. The scheme of the furrows formation method with a variable density of the furrows bottom.

- I. Rough alignment of irrigated areas;
- II. Creation of a furrow on a given slope;
- III. Seal the furrow bed along the design slope.

Legend:

- - surface mark of the planned area
- - mark the bottom of the formed furrow;
- . - . - mark the bottom of the furrow formed by the seal to the design value;

h_{min} - the required minimum depth at the beginning of the furrow, m;

h_{dd} - design depth of the cut furrow, m;

i_p - the slope of the surface of the planned area;

i_f - slope of the formed furrow;

i_d - design slope of the groove formed by the seal.

This technology allows for the use of automated control of the working body in the production of agricultural industrial crops when cutting furrows, save water on irrigated areas and achieve high yields due to the sustainable development of crops [4].

The proposed technical tool relates to agricultural machinery, in particular to tools for the care of row crops, irrigated crops.

The purpose of the invention is the creation of uneven soil compaction in the furrow bed along its length, with a change in soil density from the maximum value at the beginning and the minimum at the end, according to the irrigation method [5]

A cotton mounted cultivator used for cutting furrows was selected for the prototype, including: cultivator ridges on which a working furrow divider is installed. The cultivator cuts the furrows relative to the prepared field surface, as a result of which the longitudinal profile of the furrow and its slope are obtained, as a rule, such as hydraulics require for an unobstructed and uniform flow of irrigation water, however, irrigation does not ensure uniform moistening of the soil-soil as the thickness of the root layer, and along the length of the furrow.

At the beginning of the furrow, from where the water is

supplied, the maximum moisture in the depth is obtained, and at the end it is minimal. Alignment of soil moisture is possible at the maximum value, but this is achieved due to the significant moistening of the overhead of irrigation water and irrigation time [6, 7, 8, 9]

The objective of the invention is the development of a device for uneven soil compaction in the furrow bed along the entire length, with a smooth change in soil density from maximum at the beginning and minimum at the end.

The problem is solved in that in the cultivator for cutting furrows containing a bed with furrows installed on it, a W-shaped frame of the seal is pivotally connected to the hydraulic cylinder of the base tractor connected to the hydraulic system, while the compactors are fixed on the lower part of the frame.

The essence of the invention lies in the fact that several sealing rollers are combined in one device and are mounted pivotally on the cultivator ridges with a frame, which are controlled simultaneously by one hydraulic cylinder and provide the possibility of uneven compaction of the furrow bed along the entire length.

In figure 2 a side view of the device is described.

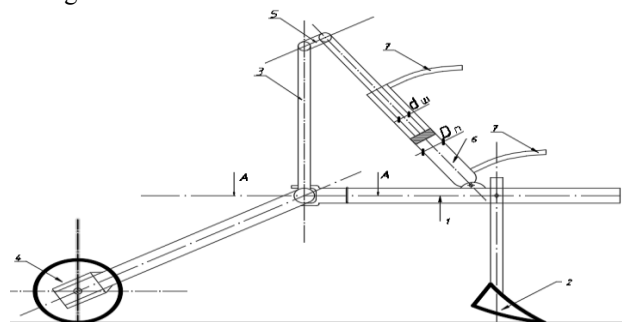

Figure 2. Device for sealing a bottom of irrigation furrows

The proposed device includes a bottom 1 with furrows 2. A hinge frame 3 with sealing rollers 4 is mounted on the lodge 1. In the upper part of the frame 3 there is an arm 5 to which the rod of the hydraulic cylinder 6 is connected, which is pivotally mounted on the bed 1. The hydraulic cylinder 6 is connected to pipelines 7 with hydraulic system of the base tractor.

The device operates as follows.

The cultivator (aggregate) is installed in the furrow head to its original position and, using the hydraulic cylinder 6, lowers the rollers and seals onto the surface of the furrow lodge, while the hydraulic cylinder rod should put the pressure on the rollers to maximum force 4. Turning on the tractor through the valve, the fluid supply to the rod cavity "A" the cultivator starts moving. When the cultivator moves, the working fluid in the hydraulic cylinder slowly raises the frame 3 and thereby reduces the pressure of the rollers on the ground, which creates a smooth change in the density of the soil from the maximum value at the beginning and the minimum at the end of the furrow. When approaching the end of the furrow, the hydraulic control lever is set to the neutral position, and with the help of the cultivator hinged system, the machine is transferred to the

Technology and Technical Equipment Ensuring a Sustainable Profile and Design Slope for Waterfurnishing

transport position, after which the unit is turned to move in the opposite direction. The cultivator (unit) is set to the opposite position. The control valve lever is converted to the opposite of the original one in order to supply fluid to the cavity of the hydraulic cylinder 6. At the beginning of the reverse movement of the unit, the fluid enters the cavity and lowers the rollers until it contacts the furrow bed, the unit starts to move. The working fluid entering the cavity slowly presses the rollers 4 creating seals from the minimum at the beginning to the maximum in the furrow head. This creates a minimum seal at the beginning and maximum at the end. Raising the frame, the unit unfolds and the process repeats. Adjustment of consistency reduction and increase of compaction force on the rollers with the speed of movement of the cultivator and the length of the furrow is carried out by the selection of the diameters of the piston and the rod of the hydraulic cylinder.

According to the position of hydraulics [3], if the piston area is twice the rod area, i.e. $F_p = 2f_{sh}$, which is respectively equal

$$d_{sh} = D_p / \sqrt{2} \quad (1)$$

then the speed of raising and lowering the rollers will be equal to:

$$V_r = V_{low} = 4 \cdot Q / \pi \cdot d_{sh} \quad (2)$$

where, Q is the fluid supply to the hydraulic cylinder;
 d_{sh} - rod diameter.

Using the proposed device allows the creation of uniform compaction of the entire cross section of the furrow bed, starting from the maximum value at the beginning and ending with zero at the end.

In accordance with the program of the innovative project "KX-A-KX-2018-529" - an applied grant on the theme "Development of new technology and technical means for creating a stable profile and design slope of furrows for the rational use of water resources", conducted in Shavat and Gurlen districts of the Khorezm region of the Republic of Uzbekistan, the Beruni district of Karakalpakstan, field research, scientific design and theoretical research prove that the scientific results of a practical grant in the future will be higher than it was expected [10, 11, 12, 13].

IV. CONCLUSION

To ensure automation (laser) by the continuous slope of the lodge of the cut furrows bottom for irrigation of technical crops (cotton) in this area, the elimination of uneven moistening of the root layer of the soil and the efficient use of water resources are achieved. This is more expedient than annually producing a laser leveling of the surface of irrigated areas.

The compaction of the soil of the bottom of the furrow along the length of the furrows by automatic regulation (that is, due to compaction at the beginning of the furrows to the maximum and at the end to the minimum value) leads to a decrease in the filtration of water resources in the root layer of the soil. This helps to improve the reclamation state of the irrigated area

This technology provides:

- increasing the efficiency of water resources by creating a sustainable profile and design slope of the furrow;
- water saving and energy saving by creating a stable profile

and slope of the furrow of the irrigated field, providing high uniformity of moistening of the root layer of the soil along the entire length of the furrows, especially when cutting them, new laser technologies and highly efficient trailed technical means and production methods were used;

-to create quickly tunable, easily replaceable, automatically controlled technical means for processing the soil of the furrow channel in order to improve the hydraulics of the flow in the furrow and to ensure uniform absorption of water along the furrow length;

-unification and standardization in the field of machines, quickly customizable, easily replaceable, automatically controlled technical means for cutting irrigation furrows of a stable profile and with a design bias.

Cutting furrows using technical means with an automated control system of the working body, using the new technology, saves water supplied during the growing season of crops on irrigated areas and as a result of the uniform development of crops, a high yield is achieved.

REFERENCES

1. Decree of the President of the Republic of Uzbekistan "On the State Program for the Development of Irrigation and Improvement of Irrigated Lands on Irrigated Lands for 2018-2019" No. UP-3405 dated November 27, 2017. (in Uzbek).
2. Atajanov A.U. "Improving the technology of planning the irrigated field along the furrows" // Collection of scientific papers. Vol. 46. Series 3.1. 69-71 pp. Ruse. Bulgaria. 2007 (in Russian).
3. Berdyanskiy V.N., Atajanov A.U. "The method of cutting irrigation furrows" // Preliminary patent No. 1114., 09/30/1997., Newsletter, Number 4. (in Russian).
4. Atajanov A.U., Berdyanskiy V.N. "A device for forming a furrow with a variable density of the soil of the bottom along its length" // Journal of Agriculture of Uzbekistan No. 1. 1999, pp. 28-29. (in Russian).
5. Atajanov A.U. "Improving the technology of planning the irrigated field along the furrows" // Collection of scientific papers. Vol. 46. Series 3.1. 69-71 pp. Ruse. Bulgaria. 2007 year. (in Russian).
6. Atajanov A.U., Irmukhamedova L.Kh., Atajanov A.A. "The technology of planning the irrigated field, providing uniform soil moisture" // International scientific journal "Young Scientist". Kazan. No. 8 (142). 2017., pp. 43-46. (in Russian).
7. Atajanov A.U., Firlina G.L. "Improving the technology of preparing the irrigated field for furrows" // Scientific and Practical Journal of the Federal State Budget Scientific Institution "Russian Research Institute of Land Reclamation Problems". Novochoerkassk. Issue No. 2 (66). 2017. pp. 60-64. (in Russian).
8. Atajanov A.U., Matyakubov B.Sh. "Improving the technology to ensure uniform wetting of the root layer of the soil irrigated by furrows" // International Scientific and Practical Conference "Water for the Sustainable Development of Central Asia". March 23-24, 2018 Dushanbe, Tajikistan, p. 237-241. (in Russian).
9. Atajanov A.U. "A new technology and technical tool for creating a sustainable profile and design slope of irrigation furrows" // Monograph. Tashkent-2018, Printing house TIAME, -126 p. (in Russian).
10. Matyakubov B.Sh. "The current state of irrigated agriculture of the Khorezm oasis" // Journal of Agrarian Science, Moscow-2005, No. 9, pp. 27-29. (in Russian).
11. Matyakubov B.Sh. Efficient use of water in the Khorezm Oasis. // Journal International Journal of Innovations in Engineering Research and Technology, volume 5, No. 11, p. 44-50. (in English).
12. Abdullaev Iskandar, Horst Mihail, Mirzaev Nazir, Matyakubov Bakhtiyar. "Water productivity in the Syrdarya river basin temporal and spatial differences" // 9 th International Drainage Workshop, 2003. (in Russian).
13. Abdullaev Iskandar, Molden David, Matyakubov Bakhtiyar. "Best water conservation practices and their impact on water productivity in the Syr Darya River Basin" // Proceedings of International Conference, Kazakh Institute of Water Management, Kazakhstan,

2005/10/21, volume -1, p. 33-41. (in English).

AUTHORS PROFILE



Prof. Bakhtiyar Matyakubov has been working at the Tashkent Institute of Irrigation and Agricultural Mechanization Engineers (TIAME) in Uzbekistan since 1988. His background is irrigation and drainage. During 1982-1987 Prof. Matyakubov graduated his University degree with honors from the Department of Irrigation and Melioration at TIAME. He worked in the Department of Irrigation and Melioration during 1988–2019 as the head of a laboratory assistant, a graduate student, an assistant, associate professor, doctoral student and professor, as well as the dean of Hydromelioration faculty and the Department of Advanced Training at TIAME.

Prof. Matyakubov conducted field experiments in the Khorezm region in the field of cotton irrigation regime and introduction of water-saving irrigation technologies. On the basis of his research work he defended his doctoral dissertation (DSc) on the topic "Scientific and practical foundations of the effective use of water resources in irrigated agriculture: In the case of Khorezm oasis" and received a doctorate in agricultural sciences. He has published over 90 scientific and methodological works, including 1 monograph, 1 patent in water management, 2 textbooks and 1 study guide. He led the defense of 1 PhD student, 12 Masters and 65 Undergraduate students.

He also serves as an Agronomy consultant at the AgroMart.uz portal. Since January 2017 he advises over 8,000 farmers in Uzbekistan.



Atajanov Adiljan Usenovich graduated with honors from the Tashkent Institute of Irrigation and Agricultural Mechanization Engineers, Faculty of Mechanization of Hydromelioration in 1978-1983. In 1990-1994 he worked as an assistant at the Department of "Using of Hydromeliorative Systems" of Yangier branch of Tashkent Institute of Irrigation and Agricultural Mechanization Engineers.

Assistant of the department "Mechanization and use of melioration and building machines" 1995-1998 y. Full-time post-graduate student and research assistant of the Department of "Organization and Technology of Hydromeliorative Works" of the Scientific Production Association SANIIRI, 1999-2005. teacher of the college and sports-technical club, 2005-2019. He is an assistant of the department "Organization and technology of hydromeliorative works", senior teacher of the department "Mechanization of hydromeliorative works".

Atajanov Adiljan Usenovich conducted field experiments in Tashkent, Syrdarya, Khorezm and the Republic of Karakalpakstan. On the basis of research, the technology of twin irrigation, which provides a stable longitudinal profile and design slope of the furrow, was developed and studied. The water-saving technology was introduced in the field. As a result of research, the saving of irrigated water was 15-20%, and the productivity of cotton increased by 6.3-7.9 centner/ha. On the basis of research works published a monograph on "New technologies and technical tools for creating a sustainable profile and design slope of irrigation furrows". 06.01.02 - Melioration and Irrigation, an independent researcher is preparing a dissertation on the topic: "Technology and technical means of improving the method of land irrigation". Author of more than 70 scientific and methodical works, including 1 monograph, 1 patent, 5 textbooks. He has supervised over 55 undergraduate students.

QX-A-QX-2018-529 - Implementer of the project grant on the theme: "Creating a new technology and technical equipment that provides a sustainable profile and design slope of the fracture cross section for efficient use of water resources".



Yulchiyev Davronbek Gulamovich graduated from the Tashkent Institute of Irrigation and Agricultural Mechanization Engineers with honors in 2015. Since 2015 year he has been working as an assistant at the Department of Irrigation and Melioration.

He is currently teaching students in the fields of water resources and melioration. In addition, he wanted to continue study to gain knowledge and experience in water management through scientific research, except that continuing his research in agricultural area gives him the opportunity to fully understanding his speciality.

He planned to conduct his research on the using of water saving technologies, such as drip irrigation while irrigating agricultural crops. For instance, by using this method it gives a huge opportunity that can save up to

40% of water than traditional way. Saving water is very urgent for our country, because we receive 80% water from the trans-bordering countries such as Tajikistan and Kirgizstan.

His dissertation topic is "Development of a scientifically based irrigation regime for drip irrigation of cotton crops on saline lands".

He had already written more than 30 scientific and methodical works, including one textbook on the topic of his dissertation. He had supervised over 25 bachelor students.

At present time, Davronbek works as a secretary of the Scientific Council of the Institute.