

# Justification of parameters of sump in machine channel

*Sanatjon Khidirov*<sup>\*</sup>, *Fotima Artikbekova*, *Ezoza Khalmuradova*, and *Bakhtigul Isakulova*

“Tashkent Institute of Irrigation and Agricultural Mechanization Engineers” National Research University, Tashkent, 100000, Uzbekistan

**Abstract.** In studies conducted in 2017-2020. It has been proved that the erosion and erosion of the Amu Darya's banks, which occur due to rapid and uneven changes in its channel, requires large expenditures for bringing water to the Amu-Bukhara channel with a damless water intake. An analysis of the pumping station data shows that the uninterrupted movement of water in the system water intake-distribution-channel-sediment retention system-system-fore-chamber-suction pipes-pumping unit-pressure pipes-consumer largely depends on the reliable operation of the structures that make up the system. As a result of the rise of water with a high content of turbidity, hydroabrasive erosion of pumping units occurs, and their service life is reduced. The article discusses the installation of sedimentation tanks in the water supply channel to the pumping station to reduce the amount of turbidity in the water; it is determined that to take the effective value of the number, the sweep angle  $\alpha$  has the boundary condition  $\alpha_{PS.inlet} \leq 44^\circ$  in the area behind the traverse dam. The angle at the exit from the clarifier is determined  $\alpha_{sump} = 180^\circ$  and corners  $\alpha_{PS.inlet} \leq 44^\circ$  on the compression zone of dams on the concreted part at the entrance to the antechamber of the pumping station Clarifiers built on these parameters provide a reduction in water turbidity.

## 1 Introduction

Providing the required amount of water for irrigating crops is one of the most important tasks in the world. In this regard, special attention is paid to water supply systems using pumping stations for guaranteed water supply to consumers. In this regard, it should be noted that such countries of the world as the USA, China, and Uzbekistan applies the method of supplying the required amount of water to the ever-increasing crop areas and selection of parameters of the inlet channel of pumping stations to ensure the necessary water consumption in pumping stations. In this regard, special attention is paid to improving the methodology for choosing the optimal parameters of the supply channels of pumping stations. Taking into account the performance characteristics of pumping units at pumping stations around the world, purposeful research aimed at improving selection methods is of particular importance to optimal parameters of the channel and improvement of the operating mode, taking into account the conditions for evaluating the processes in the

---

\*Corresponding author: [sanat.kx@mail.ru](mailto:sanat.kx@mail.ru)

supply channel. At the same time, the development of new approaches to assessing bottom processes to ensure the stability of the culvert bed of the supply channel of pumping stations. At the same time, the development of measures to improve the operational regime by reducing the introduction of turbid sediments into pumping stations is among the important tasks, creation of a mathematical model that reflects the movement of the flow in the supply channel, regulation of the normal water level in the fore-chamber. In this direction, it is important to develop new approaches to assessing channel processes to ensure the culvert capacity of the channel of the inlet channel of pumping stations [1-7].

Currently, measures are being taken in the republic to rebuild and reconstruct pumping stations to provide a guaranteed amount of water required for crops, determine the optimal parameters of the supply channels, improving the operating mode by controlling the hydraulic and alluvial flow regime in the cascade of pumping stations.

Theoretical and practical studies to study the nature of the flow in the inlet and machine channels of pumping stations and improvement of the operating mode of pumping stations are reflected in the scientific works of domestic and foreign scientists. Such researchers as A.A. Shokirov, A. Tozhiboev, and D.R. Bazarov were engaged the uniform movement of water in the pipes, and positive results were obtained. In the works of scientists M.R. Bakiev, M.A. Mamazhonov, M.M. Muhammadiyev, Sh.Kh. Rakhimov and others describe in detail the problems of the influence of turbid sediments on work productivity pumping stations, the ways of their solution have been studied, the positive results of which, to a certain extent, are successfully applied in practice. The article presents the results of a study on the assessment of flow movement in the inlet channel and the installation of a clarifier in the inlet channel to improve the regime operation of pumping stations, taking into account the operational features of the pumping stations of the Abu-Bukhara machine channel. Such scientists as S.K. Abalians, V.S. Altunin, K.V. Grishanin, K.V. Zheleznyakov, Yu.A. Ibodzoda, A.A. Kodirov, R.M. Karimov. As a result of these studies, methods were developed with the conditions for preventing the accumulation of sediments, erosion of the channel, the choice of structural elements, effectively settling sediments as part of a moving stream, and parameters of morphometric elements of the channel [8-15]. As a result of these studies, recommendations were developed for choosing the most hydraulically optimal sections of channel sections and ensuring their efficient operation under certain hydrological conditions. It should be noted that the degree of reliability of the hydraulic design method developed by the above scientists is based on lifting forces. The experiment results estimate it, but if the method is based on the allowable limiting speeds, then it is limited by the data. These features are what distinguish these methods.

The provision of the water flow with uniform, stable movement and stability of water consumption also eliminates the process of sedimentation of the channel by sediments in the channels between pumping stations. However, the non-fulfillment of the requirements of the hydraulic regime of the water flows of the supply channels and their dynamics cause various processes in the channel.

Considering the above factors, it is advisable to reconstruct the hydraulic mode of the inlet channel and adapt it to the operating mode of the pumping station.

Of course, simultaneously with implementing these measures, the performance of the AB-1 pumping station will increase the effective management hydraulic and alluvial regime of the water flow entering the supply channel and the fore-chamber.

**Table 1.** Requirements for the Reconstruction of the Inlet Channel of the Amu-Bukhara Engine Pumping Station

№	Name of activities and work to be implemented	U measurement	Overall volume	Volume distribution by years					
				I	II	III	IV	V	VI
1	Management of the bed of a damless water intake and construction of bank protection dams	km	15	7	7	7	-	-	-
2	Number of dredgers to be replaced	PCS.	10	2	2	2	2	2	-
3	Replacement of pumping units with pumping units with high operating efficiency	Set	12	2	2	2	2	2	2

The composition of the water flow coming from the inlet pipe to the fore chamber of the pumping station must comply with the following regulatory requirements (Table 2).

**Table 2.** Requirements for the flow of water in the supply channel

The composition of the withdrawn water flow	Quality assessment in points	Water quality parameters	
		Turbidity of the flow, kg/m <sup>3</sup>	Flow saturation with sediments, kg/m <sup>3</sup>
Absolutely pure	4	0.5 before	До 0.05
Clean	3	$0,5 \leq \rho < 1.5$	$0.05 \leq \delta < 0.3$
Low pollution	2	$1.5 \leq \rho < 3$	$0.3 \leq \delta < 0.6$
heavy pollution	1	Above 3	Above 0.6

$\rho$  – flow turbidity;  $\delta$  - sediment water pollution

$$\rho = \frac{Q_{sus.sed.}}{Q}; \quad \delta = \frac{W_{sed.vol}}{W}$$

where  $Q_{sus.sed.}$  is the suspended sediment flow;  $Q$  is the consumption of water supplied to the National Assembly;  $W_{sed.vol}$  is sediment volume;  $W$  is volume of water flow.

Creating a mathematical model based on hydrodynamic equations that reflect the movement of the water flow during the implementation management of the hydraulic and alluvial regime of the supply channel and pumping stations is the most important and relevant but very complex issue.

The real object of research was the real input channels of the ABMCh with a length of 31 and 35 km from AB-1 to AB-2, which are the main channels providing water to the Bukhara and Navoi regions, which, in turn, are the main strategic raw material bases of cotton in the southern region of the Republic of Uzbekistan [16-20].

## 2 Methods and Materials

Solved complex mathematical problems related to the integration of the differential equation of Saint-Venant when determining the parameters that determine the unstable

movement of the water flow in the channels of the channels. The solution is found by accepting additional and compound conditions of the Saint-Venant differential equation by defining the model unstable flow, which was introduced before the advent of computers.

Depending on the complexity of the conditions causing the unstable water flow in the river, models of unstable water flow are divided into stochastic, conceptual, and hydrodynamic models.

Position ( $\alpha=1$ ) values of the correction of the number of motions of the Saint-Venant equations, written based on the law of conservation of momentum of mass and force for the Saint-Venant equation system, has the following form:

$$\frac{\partial \omega}{\partial t} + \frac{\partial Q}{\partial x} = q \quad (1)$$

$$\frac{\partial Q}{\partial t} + \frac{\partial Q^2 / \omega + gS}{\partial x} - g \frac{\partial S}{\partial x} \Big|_{Z_{fs}=c} + \frac{\lambda}{2} v^2 \chi = r; \quad r = \begin{pmatrix} qv & q < 0 \\ qv_{in} & q > 0 \end{pmatrix} \quad (2)$$

here:  $t$  is the time,  $x$  is the longitudinal coordinate along the channel,  $\omega$ - moving cut surface,  $Q = \omega v$  is flow rate,  $v$  is average flow rate,  $S = \omega h_c$  is a static moment of water flow concerning step curve, which is determined by multiplying the center of gravity of the flow ( $h_c$ ) on the surface of the cross-section of a moving stream,  $\chi$ - wet perimeter,  $Z_{fs}$  is water level indicator,  $g$  – acceleration due to gravity,  $q$  is specific discharge (per unit of channel length), at additional costs in the calculation area  $q > 0$  or  $q < 0$  or water intake  $q < 0$ ,  $v_{in}$  is the velocity of the flow entering the calculated area of the channel from the outside. When the water flow leaves the computational domain, the one-component scheme assumes that the power impulse depends only on the average flow velocity,  $\lambda = \frac{2g}{C^2}$  is

Darcy coefficient or hydraulic resistance, (1) the equation represents the conservation of the mass of the water flow and reflects the sum ( $p$ ) of the density of the liquid in the continuity equation; The second equation (2) is the product of the equation of motion and the density of the water flow, which is the law of conservation of momentum. It should be noted that the density  $r = \text{const}$  for liquids it is unchanged, and for gases, it has a variable character. Since this system of equations was originally used for gases, the state of density variability was also considered.

The second equation is the law of conservation of momentum.

Consider the essence of some parameters included in the equation of motion:  $Q^2 / \omega$  is the ratio of the amount of movement of the flow in the alignment to  $\rho$  density;

$gS$  is hydrostatic pressure  $\frac{\partial gS}{\partial x} - g \frac{\partial S}{\partial x} \Big|_{Z_{fs}=c}$  unit of water pressure  $\rho$ ),  $\frac{\partial gS}{\partial x}$  is pressure

change along the channel,  $- \delta y$ ,  $g \frac{\partial S}{\partial x} \Big|_{Z_{fs}=c}$  is pressure not taken into account by the above

parameter,  $\frac{\lambda}{2} v^2 \chi$  is channel hydraulic resistance;  $g \frac{\partial S}{\partial x} \Big|_{Z_{fs}=c}$  is parameters look simple for

very wide channels or quadrangular shapes:  $g \frac{\partial S}{\partial x} \Big|_{Z_{fs}=c} = g \omega I$ .

For this mathematical model, the following boundary conditions were adopted. Initially, the boundaries of the regions in which the flow of water is represented by the hydrodynamic equations of Saint-Venant are considered in two ways: Limits at which the depth of the water flow is different from zero;

There can be no doubt that the first boundary will exist since, in this area, there will be movement of water flow at a certain depth. Of course, the depth value is taken equal to zero in the area of the line of intersection of the coast with the water level, where there is no movement of the water flow. Based on the characteristic properties of the Saint-Venant equations, there can be three situations that specify the number of boundary conditions for the first position:

If there is a calm flow at the boundary, one boundary condition is assumed. When the boundary is considered a vertical wall, the flow velocity at the boundary is assumed to be zero. At the boundary of the input and output of the computational domain, the boundary condition of the interdependence of the water flow rate and the depth of a calmly moving water flow is preserved, receding towards the region of uncertainty. For example, it is required to accept the natural condition that when river water flows into a reservoir, the water flow from the river is equal to the water level in the reservoir. When calculating such problems, two-dimensional schemes are convenient, in which the boundary is taken at such a distance that the flow significantly reduces its influence on the inflow. Such types of boundary conditions can be exemplified by the conditions that characterize the relationship between water discharge and flow velocity in spillway structures. And in the area of the water outlet, patterns of change in flow rate and depth over time are presented. Suppose the numerical calculation starts with a discharge or extinguishing facility. In that case, it is reasonable to represent the flow over time because determining the flow of water coming from the spillway is not very complicated. If the calculated section of water flow begins at the confluence of two streams in the unstructured part of the section of the flow, then the boundary condition is taken as a law in which the law of water level change can be determined;

Empirical formulas obtained by Y.S. Mukhamedov and U.Kh. Arabov were used to determine the permeability of the water flow in the sediment.

The following figure shows the layout of the clarifiers, which will be built at the first and second pumping stations of the Amu-Bukhara Machine Channel:

Thus, the analysis of suspended sediments shows that the sediments tend to increase the number of sand fractions. At the same time, the amount of sandy silt decreases in the direction from the entrance to the main building of the AGMCh.

The main goal of experimental studies is the effective control of the hydraulic and alluvial flow regime of water in the supply channel to the pumping station. The object of the study was the Amu-Bukhara channel, which passes through common ground channels. One of the main factors in the failure of pumping units is the construction of an irrigation clarifier on the channel bed, which keeps hard sediments in the stream.

Taking into account the fact that the bottom of the clarifier, filled with sediment, is cleaned with water from the Amudarya River, the water of which is one of the most turbid in the world, it is necessary to carry out work to provide it with hydraulic installations with at least two or more chambers and with mandatory flow control.

This clarifier will ensure the complete settling of sediments, the supply of purified water to the pumping units of the station, and the solution of all problems for the uniform distribution of settling of sediment fractions of various shapes and sizes. In addition, sediments settle faster in the inlet and outlet sections of the stations, while sediments settle more slowly in the outlet.

The results of many years of experimental studies have shown that many suspended nanoparticles seep into the pumping station when clarifiers are not working.

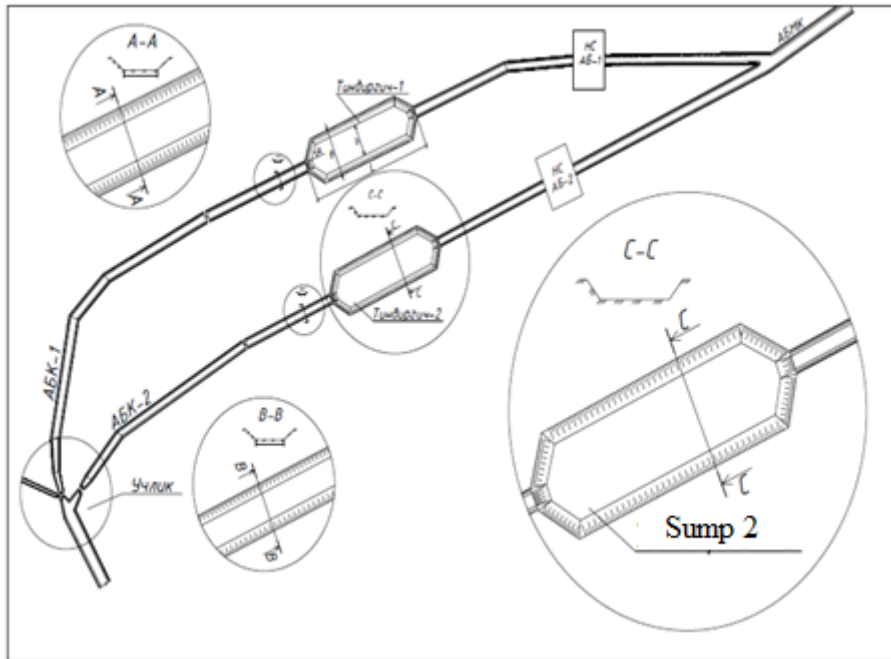

**Fig.1.** Linear scheme of clarifiers in water supply channels to pumping stations AB-1 and AB-2.

### 3 Results and Discussion

In the experimental setup, the water flow is received from the supply pipe through grid 2, which dampens flow fluctuations, and is fed to the receiver 3. The receiver is connected to tray 4. Near its end, there is a mobile shutter with shutters 5, which regulates the water level in 4. Through tray 4, water enters tray 6, where the conductor meter is installed 7. The angle of the Thomson water meter is 90°, and it has sharp edges. A jet of water from a measuring tray flows into the reservoir. In the experiments, the water flow output was achieved, corresponding to the operating characteristics of the pumping units in the mobile gate complex 5. An inlet channel of the Karshi main channel and a clarifier in it are built inside the tray so that the flow movement is carried out following the selected criteria. As mentioned above, the experimental equipment was installed in the receiver 3, and the shaft 9, spillway 10, is connected to the pump tunnel. In this tunnel 11, the movement of the water flow is free-flowing; it enters the apron and the water injection tank 12 through the expanding channel. In it, the quenched flow enters the channel tray through the outlet hydraulic unit, draws a uniform movement, and enters the area investigated in the dissertation work. The experimental equipment is completed at the entrance to the reservoir 13; in this part, the level at the upstream of the hydraulic structure is controlled by a piezometer 14. The piezometer in the conductor-measuring water 7 is modeled in the VB GTS 15, and from it, the water flows through the annular conductor into the mine, which is designed like a water reservoir. The diameter of the supply pipeline is 4000 mm, and it supplies water to the receiving tank. The diameter of the supply pipe is 4000 mm, which provides water to the receiving tank. For the experiment, a check valve system and water flow control devices were installed. Complete sedimentation occurs due to the lack of speed modes in the input and output contact pads of the clarifier in ABMK. Complete subsidence of sediments, of course, will lead to the deposition of fractions smaller than 0.0015 mm, which will increase the amount of work to clean the bottom, bring them to the fields and

serve to increase productivity. Therefore, the laws for determining the throughput of a particular current do not work in all sections of such structures, in particular, in the input and output sections. With this in mind, the clarifier must have such a shape and design that the current carrying capacity over the entire cross-section and length of the clarifier obeys the same law. From an operational point of view, fractional settling of sediments should be envisaged, and the re-uplift of settled sediments should be prevented.

Therefore, in the course of research in this direction, the condition was chosen that the bottom of the clarifier should gradually expand, the area of the subsequent output should be equal to the width in the plan, and the shape should be similar and uniform in geometric dimensions with the sedimentation area. In addition, in the area behind the clarifier, a uniform movement of the water flow is predicted, and it is envisaged that the flow rate will be less than the indelible velocity. It was accepted that the initial section of the entrance to the fore-chamber, near the connecting part with the inlet part of the channel, is polished with concrete lining. This shape, which has proven its effectiveness in practice, looks like several trapezoidal shapes lying on top of each other at the bottom of the clarifier. This ensures a convenient connection of the clarifier with the input part.

In the scheme of the clarifier, such parameters have been achieved that the nano-bearing capacity of the water flow is determined based on the above formula over the entire cross-section of the clarifier, and it was found that the sediments settle in stages, with a decrease in the size of the fractions, depending on the successive deceleration of the flow rate.

The clarifier length  $L$  was determined based on practical techniques in existing river hydraulics and was based on experimental studies.

**Table 3.** Determination of clarifier length for different sediment fractions

$d, mm$	$w_0, m/s$	$\varepsilon$	$w' = w_0 - \varepsilon\vartheta$	$h_1$	$l=(h_1\cdot\vartheta)/(w_0-\varepsilon\vartheta)$
0.5	0.0524	0.04	0.0476	2.10	1764.7
0.30	0.03	0.04	0.07	2.10	1200
0.20	0.0188	0.04	0.0812	2.10	1034.5
0.10	0.0058	0.04	0.0942	2.10	891.7

## 4 Conclusions

Conclusions on the presence of speed in the interface sections in the inlet and outlet pipes of ABMCh:

1. It has been substantiated that one of the main causes of breakdowns and malfunctions in pumping stations that occur during the operation period is an excessive amount of sediment, mechanical particles in the composition of water and their negative impact on devices and installations;
2. The necessity of taking measures to sharply reduce the parameters of the hydraulic characteristics of the inlet channel for the normalized supply of the required amount of water to the channel of the inlet channel, which is the object of study, is justified;
3. Based on the boundary conditions adopted for the created model, test problems were calculated for situations with morphometric changes in the water flow in the channel and verified for a specific calculation object;
4. The method of reducing turbid effluents entering pumping stations has been improved through the construction of a clarifier;
5. The morphometric dimensions of the accepted clarifier were determined. It has been substantiated that with the help of a clarifier, 70 percent of all sediments coming with the water flow are retained.

6. It is substantiated that with a sharp change in the operating mode of the pumping station, a sharp change in the dynamics of the flow moving in the channel of the supply channel is eliminated.

## References

1. Mukhammedov Ya. S. Eksploatatsiya Karshinskogo magistral'nogo kanala pri vodozabore iz r. Amudar'i i puti yego uluchsheniya. <http://www.cawater-info.net/library/rus/mukhamedov1.pdf>.
2. Bazarov D. R., Norkulov B. E., Markova I. M., Yermilov M., and Tadzhiyeva D. O. About constructions for the protection of water supply channels from sediment load and driftwood. *Agricultural Scientific Journal*, **8**, pp.69-75 (2019)
3. Nagata N., Hosoda T., and Muramoto Y. Numerical analysis of river channel processes with bank erosion. *Journal of Hydraulic Engineering*, **126**(4), 243-252 (2000)
4. Cantelli A., Wong M., Parker G., and Paola C. Numerical model linking bed and bank evolution of incisional channel created by dam removal. *Water Resources Research*, **43**(7), (2007)
5. Darby S. E., Alabyan A. M., and Van de Wiel M. J. Numerical simulation of bank erosion and channel migration in meandering rivers. *Water Resources Research*, **38**(9), (2002)
6. Duan J. G., and Julien P. Y. Numerical simulation of the inception of channel meandering. *Earth Surface Processes and Landforms: The Journal of the British Geomorphological Research Group*, **30**(9), pp. 1093-1110 (2005)
7. Krutov A., Norkulov B., and Jamalov F. Results of a numerical study of currents in the vicinity of a damless water intake. In *IOP Conference Series: Materials Science and Engineering*, **1030**, p. 012121 (2021)
8. Bazarov D., Vatin N., Norkulov B., Vokhidov O., and Raimova I. Mathematical Model of Deformation of the River Channel in the Area of the Damless Water Intake. In *Proceedings of MPCPE 2021*, pp. 1-15. (2022)
9. Bazarov D., Markova I., Khidirov S., Vokhidov O., and Raimova I. Coastal and deep deformations of the riverbed in the area of a damless water intake. In *E3S Web of Conferences* **263**, p. 02031, (2021)
10. Averkiev A. G., Makarov, I. I., and Sinotin, V. I. Damless water intake structures. Moscow, Leningrad: Energiya (1969), p. 164.
11. Bazarov D., Norkulov B., Vokhidov O., Jamalov F., Kurbanov A., and Rayimova I. Bank destruction in the middle section of the Amudarya River. In *E3S Web of Conferences*, **274**, (2021)
12. Bazarov D., Umarov S., Oymatov R., Rayimov K., and Raimova I. Hydraulic parameters in the area of the main dam intake structure of the river. In *E3S Web of Conferences*, **264**, (2021)
13. Bazarov D., Vatin N., Kattakulov F., Vokhidov O., Rayimova I., and Raimova I. Irrigation sedimentation tanks in the bed of the pumping station inlet channels. In *E3S Web of Conferences*, **274**, (2021)
14. Romyancev I. S., and Klovskiy A. V. Scientific review of the knowledge of the design and reliable operation of the damless water intake structures. *The International Technical-Economic Journal*, **2**, pp.101-106 (2014)



15. Eshmirzaevich N. B., and Abdujamilevna K. D. Research results of flow hydraulic and sludge sediment regime in a river without a dam. *American Journal of Technology and Applied Sciences*, **7**, pp. 13-22 (2022)
16. Eshev S., Gaimnazarov I., Latipov S., Mamatov N., Sobirov F., and Rayimova I. The beginning of the movement of bottom sediments in an unsteady flow. In *E3S Web of Conferences* **263**, (2021)
17. Latipov S., Gayimnazarov I., Eshev S., Babajanova I., Babajanov Y., and Shodiev B. Calculation of bottom sediment discharge in trapezoidal channels. In *E3S Web of Conferences*, **264**, (2021)
18. Urishev B., Eshev S., Nosirov F., and Kuvatov U. A device for reducing the siltation of the front chamber of the pumping station in irrigation systems. In *E3S Web of Conferences*, **274**, (2021)
19. Eshev S., Rakhimov A., Gayimnazarov I., Isakov A., Shodiev B., and Bobomurodov F. Dynamically stable sections of large soil canals taking into account wind waves. In *IOP Conference Series: Materials Science and Engineering* **1030**(1), (2021)
20. Norkulov B., Ishankulov Z., Kurseitov A., Nizamiev R., Asadov S., and Pateyev A. The adjustment work canal on the Amudarya in the areas of the damless water intake. In *E3S Web of Conferences* **274**, (2021)