

PAPER • OPEN ACCESS

Study on automatic water level detection process using ultrasonic sensor

To cite this article: A Djalilov *et al* 2023 *IOP Conf. Ser.: Earth Environ. Sci.* **1142** 012020

View the [article online](#) for updates and enhancements.

You may also like

- [Kalman filtering to real-time trace water level measurements using ultrasonic sensor](#)
B H Iswanto, I F Parmono and M Delina
- [Water level control based fuzzy logic controller: simulation and experimental works](#)
M Khairudin, AD Hastutiningsih, THT Maryadi et al.
- [Satellite observed recent rising water levels of global lakes and reservoirs](#)
Nan Xu, Yue Ma, Zhongwang Wei et al.



Free the Science Week 2023 April 2–9

Accelerating discovery through
open access!

 www.ecsdl.org [Discover more!](#)

The banner features a dark blue background with a futuristic, glowing blue circular interface. A hand is shown pointing at the interface, which includes a central padlock icon. The text is in white and light blue, with the ECS logo and website URL in white.

Study on automatic water level detection process using ultrasonic sensor

A Djalilov^{1*}, E Sobirov¹, O Nazarov¹, S Urolov², and I Gayipov³

¹Department of Electrical Engineering and Mechatronics, “Tashkent Institute of Irrigation and Agricultural Mechanization Engineers” National Research University, 100000 Tashkent, Uzbekistan

²Faculty of Electronics and Automation, Tashkent State Technical University, Tashkent, Uzbekistan

³Department of Electrical Engineering and Metrology, Karakalpak State University Named After Berdakh, 230115 Nukus, Uzbekistan

*Email: aduuz@mail.ru

Abstract. Currently, we live in a world where all fields are developing very rapidly. In particular, the field of water management is developing day by day, and the water supply system is being intelligent automated. Nevertheless, mechanical means and human labor are used to monitor the water level in many water management facilities of our region. This situation causes many problems in the automatic management of the system. In this article, we will consider the process of automating the measurement and control of water level, that is, an automated system that helps to know when the water in the tank is full or empty. In the automation of this system, an ultrasonic sensor that meets the requirements of the time was used. The working principle of ultrasonic sensors is based on the movement of ultrasonic waves over time. The analysis of the results of this experiment showed that the water level measurement and control system did not make more than 1.5% error in different values of the water level. This situation showed that the developed system can be effectively used in all water level control facilities.

1. Introduction

Recently, information technologies are widely used in industry, that is, applications based on simple and complex automation [1]. Water resource storage devices such as water reservoirs and water tanks are used to store water resources in farms and industrial enterprises. Of course, the water level should be monitored in these objects to prevent any negative consequences and to collect the necessary information on the water level. When monitoring water resources in the facility, remote monitoring and data collection systems are needed to collect data based on predetermined values and deliver processed information to the user when necessary or to make decisions in complex situations. The trend of information technology has revealed research directions, including the study of systematic assessment of water properties by using a sensor that converts mechanical quantities into electrical quantities and its tools, classification of water quality for human use, which helps human health and the ecosystem [3, 4, 5, 6, 7].

Currently, every industry professional has very little time, and they try to use their working time effectively. Therefore, they will not have time to constantly monitor the water level. Water is a necessary resource every hour of our life [8].

The main goal of the article is to develop a device that measures the water level in the tank and notifies the user about the water level through SMS alerts. Currently used water level measurement



and control tools have several shortcomings. For example, if we take the water level monitoring gauges, it must be constantly monitored by a person, the level of accuracy is very low, and automation is difficult. We can give many such examples. Such water level measuring devices do not meet the requirements of today's era. In this article, the water level was measured using an ultrasonic sensor. The waves produced by the ultrasonic sensor are sent to the water tank, their time of propagation and return is recorded, and after several measurements, we get accurate information about the water level in the tank. The water pump motor automatically turns on when the water level drops and turns off when the tank is full. This information is sent to our phones via GSM module as an SMS notification. Such a process helps to effectively store water in the tank, but also stabilizes it for our daily tasks, prevents water wastage, and reduces excess costs.

2. Methods

The automatic water level measurement system using an ultrasonic sensor and GSM module helps the user to be aware of the water level in the tank through SMS alerts, and the pump will automatically start or stop when the water in the tank reaches a certain level limit [9]. The automatic system is based on the Arduino platform (Figure 1), it has a simple connection with other devices and the program written on the computer can be easily loaded [10]. At the same time, it provides a continuous measurement of the water level. These features of the system are of great importance, in which it is necessary to obtain detailed information on floods and water depletion in the controlled object. It not only helps in daily activities but also prevents wastage of water. It reduces human labor, saves time and also keeps the user informed about the water level status.

We form the structure of the water level measurement and control system in the tank as follows.

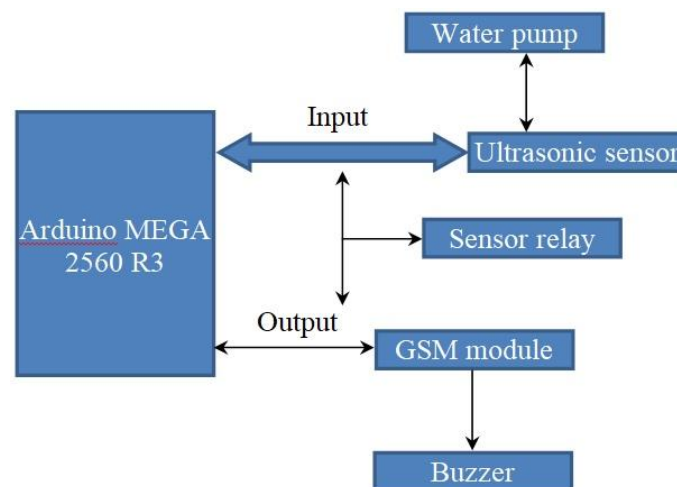

Figure 1. System architecture

Let's briefly get acquainted with the elements of the system architecture.

Arduino MEGA 2560 platform

The Arduino MEGA 2560 platform system works as follows (Figure 2). The platform is connected to a laptop or PS computer and the necessary software is loaded into it. With the help of a downloaded special program, data is processed and a specific command is executed [10].

The Arduino is powered by a USB port or an external power supply.

If you choose a non-USB power supply from an external power source, you can connect a battery or power supply (voltage converter) [12].

After the platform is supplied with voltage from the source, the devices on the other board are connected to the V_{in} and Gnd pins of the platform through electrical networks (wires).

When the platform is supplied from a separate source, the voltage is 7-12 V + 5 V is available when charging via USB. Arduino Mega specification is shown in Table 1.

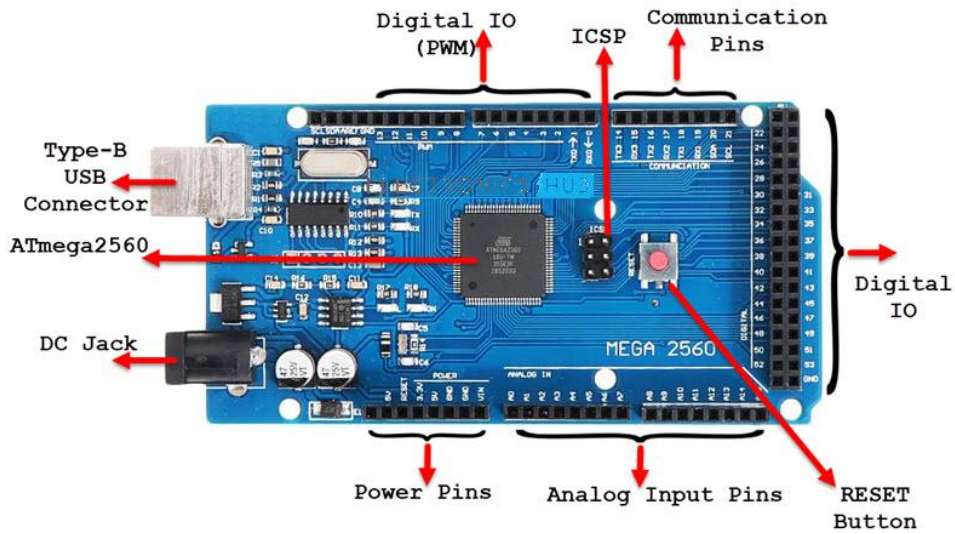

Figure 2. Arduino MEGA 2560 platform

Table 1. Arduino Mega 2560 Specifications

Microcontroller:	ATmega2560
Clock frequency:	16 MGts
Operating voltage:	5 V
Fixed voltage:	7-12 V
Nominal current:	40 mA
Digital input/output (pins):	54
Analog inputs (pins):	16
Flash memory:	256 KB (of which 8KB is used by the bootloader)
SRAM (static random access memory):	8 KB
EEPROM (Electrically Erasable Programmable Read-Only Memory -)	4 KB

Ultrasonic Sensor (HC-SR04)

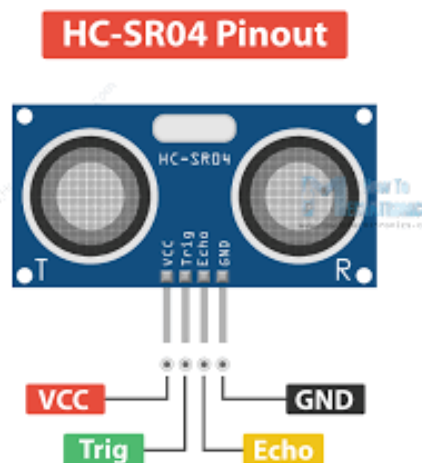

Figure 3. Pin configuration of the ultrasonic sensor (HC-SR04)

The HC-SR04 ultrasonic sensor is based on the technology of emitting and receiving ultrasonic sound just like a bat. The sensor emits a sound pulse at a frequency of 40 kHz and hears the sound.

Compared to other sensors, HC-SR04 does not focus on sunlight and black objects. It is slightly sensitive to thin objects and knitted materials and the accuracy of reporting may decrease [12,18].

Two ultrasonic sensors are placed in the front part of the HC-SR04 sensor: T (Transmitter) — a sensor that transmits ultrasonic waves (TCT40-16T), and the other one is R (Receive) — a sensor that receives reflected ultrasonic waves (TCT40-16R). In the center is a summing quartz generator operating at 27 MHz [15].

On the back of the sensor there are three main microcircuits and four output contacts are removed so that they can be connected to the Arduino platform.

Functions of sensor pins [17,18,19] (Figure 3):

- VCC: «+» module supply
- GND: «-» module supply
- Trig: input signal output (pin)
- Echo: output signal output (pin).

The HC-SR04 sensor sends ultrasonic waves into the container, which are then reflected back (Figure 3). The speed of propagation of these waves is in the range of 340 meters per second, and they are not affected by obstacles that may be encountered in their path. The time of passage and return of these waves is recorded and the water level is calculated.

GSM Modem SIM 900

It is widely used in mobile communications. It has a built-in RS232 level converter, SMS has the ability to send SMS using cell broadcast method.

With a baud rate of 9600 - 115200 bps, it can send or receive SMS at a very fast rate. In addition, it has low power consumption, which is one of its main advantages [13].

The GSM modem (Figure 4) is used to send a message about the state of the water level in the tank, as well as to start or stop the electric motor when the water in the tank reaches a certain level. He sends the necessary information about the water level to the dispatcher via SMS.

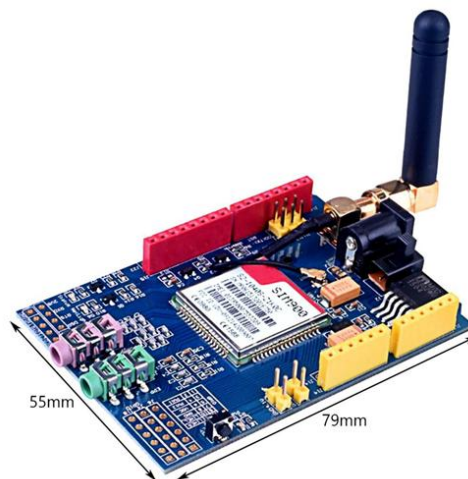

Figure 4. SIM 900 GPRS/GSM module

3. Results and Discussion

Nowadays, almost all digital devices use an internal voltage source of 5 V. This voltage is usually called the reference voltage and must be stable. Otherwise, the fluctuation of the amplitude of the source voltage will cause an additional error. We used the Arduino MEGA 2560 R3 platform during the experiment and it also has an internal reference voltage of 5V. Figure 2 shows an overview of the Arduino MEGA 2560 R3 platform.

But this platform can also use the computer USB port as a source, in which case the base voltage of the Arduino MEGA 2560 R3 platform varies from 4.95÷5.05 [14]. During the experiment, 4.91 V was also observed in some cases.

Usually an external source voltage is needed to convert the primary converter data to voltage to operate the analog-to-digital converters. For example, when the base voltage is 5 V and the resistive primary angle shift converter voltage is 1 V, the result can be written as follows [15]:

$$\frac{V_R}{V_{\text{base}}} \cdot N = \frac{1}{5} \cdot 1023 = 204 = 1000000100 \quad (1)$$

Because the Arduino MEGA 2560 R3 platform uses 10-bit ADC. However, using an oscillating voltage with an amplitude change of ± 40 mV, the converted value of the voltage is equal to the following [14]:

$$\frac{V_R}{V_{\text{base}}} \cdot N = \frac{1}{5,04} \cdot 1023 = 202 = 0011001010,$$

or

$$\frac{V_R}{V_{\text{base}}} \cdot N = \frac{1}{4,96} \cdot 1023 = 206 = 0011001110_{(-40V)} \quad (2)$$

But in such platforms, using multi-mode power sources, fast switching transistors are used in its electrical circuit, and as a result, high-frequency noise appears in the circuit [14]. According to the results of scientific studies, the noise of such a connector is 1-15 mHz.

In order to filter such a noise signal, capacitors with 10 pF - 22 pF are connected to the power source circuit [15]. Figure 5 below shows the noise filtering scheme that occurs in the power source.

These capacitors pass the AC signals from themselves. Capacitors with a small value filter out high-frequency noise, and capacitors with a large value filter out low-frequency noise.

Usually there are ceramic capacitors with a capacity of 1 pF \div 0,1 μ F and their voltage is around 16-50 V [16].

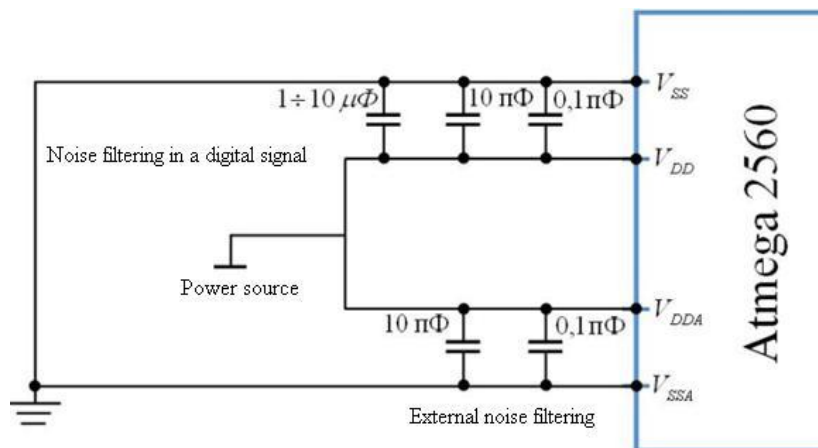

Figure 5. Noise filtering scheme in the power source

The working principle of the water level measurement system in the tank.

When the system is activated, the ultrasonic sensor transmits a sound signal to the bottom of the water tank, which is the target and the water level to be measured. When the ultrasound wave hits the bottom of the container, the signal is reflected back and received by the receiving part of the ultrasound sensor. The time spent on the entire path of the transmitted signal is recorded. Block diagram of water level measurement and control in the tank is shown in Figure 6.

This expression determines the water level measurement range of the sensor.

Range = {(elapsed time) X transmitted signal speed (ie 340 m/s)}/2.

$$H = \frac{t \cdot C}{2} \quad (3)$$

Here, t is the propagation time of the ultrasound wave, C is the speed of the transmitted signal [20].

The result obtained represents the distance at the current time.

This measured level, if the water in the tank is 2 cm below the set threshold level, the pump will start automatically and an SMS message will be sent to the user's phone. When the water in the tank reaches the upper limit level, the system will automatically turn off and the user will be notified via SMS that the tank is full (Figure 7).

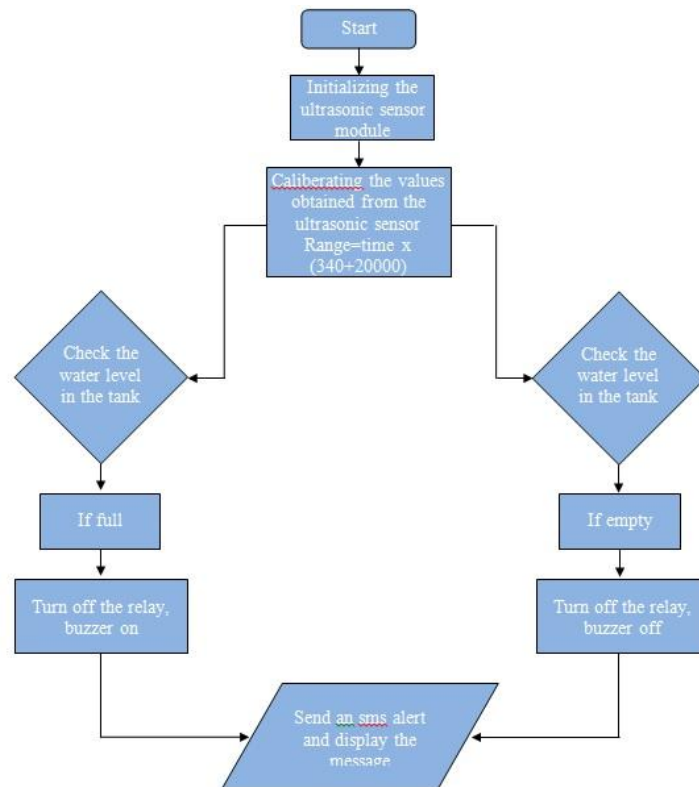

Figure 6. Block diagram of water level measurement and control in the tank.

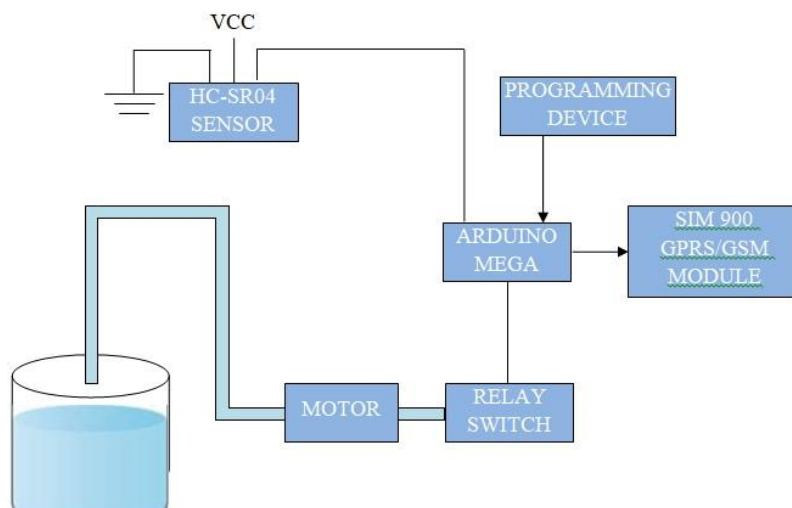

Figure 7. Structural scheme of measuring and controlling the water level in the tank

Analysis of the obtained results

As we know, the static and dynamic characteristics of any developed device are studied. n=14 points were obtained in the experiment (Table 2).

Table 2. Results on the abscissas (x_i and y_i)

Individual experiment number (i)	Each result on the abscissa axis x_i, mV	Each result on the ordinate axis y_i	x_i^2	$x_i \cdot y_i$
1	0	1	0	0
2	5	2	25	10
3	7	3	49	21
4	12	4	144	48
5	19	5	361	95
6	21	6	441	126
7	26	7	676	182
8	31	8	961	248
9	36	9	1296	324
10	44	10	1936	440
11	46	11	2116	506
12	51	12	2601	612
13	57	13	3249	741
14	61	14	3721	854
Σ	416	105	17576	4207

Entering the values of the Table 1 into the formula (4), we create a system of equations (5):

$$\begin{cases} x_i a + i \cdot b = y_i \\ x_i^2 a + x_i \cdot b = x_i \cdot y_i \end{cases} \quad (4)$$

$$\begin{cases} 416a + 14b = 105 \\ 17576a + 416b = 4207 \end{cases} \quad (5)$$

By solving this system by Gauss or Kramer method, coefficients a and b are found as follows.

$$a=0.20844; b=1.306385, \quad (6)$$

By inserting the found coefficients into the expression $V_{out}=a \cdot V_{inp}+b$, we get the following:

$$V_{out}=0.20844 \cdot V_{inp}+1.306385. \quad (7)$$

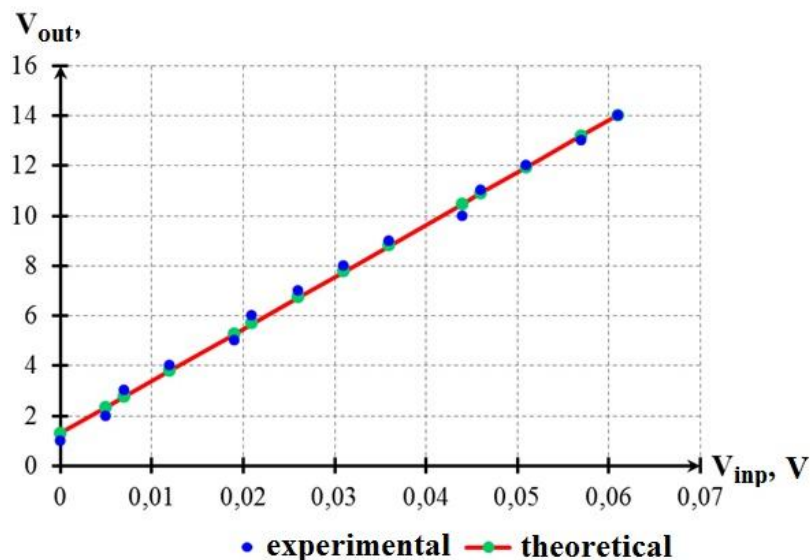

Figure 8. Static characteristic of the sensor

Based on the expression (7), we construct a graph of dependence on the static characteristic of the sensor $V_{out}=f(V_{inp})$. This graph is presented in Figure 8. In the graph, we analyze the values and errors obtained as a result of approximation and experiment.

As we know, this error is calculated by the sum of squared errors:

$$\sum \delta^2 = \sum_{i=1}^n [y_i - f(x_i)]^2 \quad (8)$$

Formula (8) is the most basic indicator showing the degree of approximation and the degree of error between the approximation and the experimentally obtained results or the mathematical model.

The results of the experiment of measuring the water level in the tank based on the developed system are presented in the following table:

Table 3. Measurement results and errors

Actual Distance (cm)	Measured Distance (cm)	Error
20	21	+1
50	49.8	+0.2
80	80	+0
110	111	+1
140	141.5	+1.5

The percentage of error is calculated as follows:

Error Percentage = [(Measured Distance-True Distance)/True Distance]*100%

%error= [(21+49.8+80+111+141.5)-(20+50+80+110+140)] / (20+50+80+110+140) *100%

%error = [(403.3 – 400)/400]*100%

%error = (3.3/400)*100%

%error = 0,00825*100%

%error = 0,825%

The analysis of the results of this experiment shows that the water level measurement and control system did not make more than 1.5% error in different values of the water level (Table 3). This situation shows that the developed system can be effectively used in all water level control facilities.

4. Conclusions

Recently, automation of various technological processes around us is being implemented on a large scale to reduce human intervention and save time. It is well known that mismanagement of water can have harmful effects on both the system and the environment. The main purpose of this article is not only to reduce manual labor, but also to use water resources efficiently.

From the developed water level measurement and control system:

- can be widely used to control the water level in dams to prevent flooding and other similar problems;
- can be used to control water loss in reservoirs that supply water to a specific area;
- can also be widely used for industrial purposes.

In general, it can be concluded that due to the minimum requirement and easy installation process of this system, it can be used on a large scale in water management facilities.

References

- [1] Pasika S, Gandla ST, 2020 Smart water quality monitoring system with cost-effective using IoT *Heliyon* **6** e04096.
- [2] Maharashtra P 2012 Sanitation and Liquid Waste Management, Gujarat, India, 2012.
- [3] Schweitzer RW, Harvey B, Burt M 2020 Using innovative smart water management technologies to monitor water provision to refugees *Water Int.* **45** 651–659.

- [4] Goda T 1988 Monitoring and measurement of water quality parameters *Int. J. Water Resour. Dev.* **4** 270–275.
- [5] Dube T, Mutanga O, Seutloali K, Adelabu S, Shoko C 2015 Water quality monitoring in sub-Saharan African lakes: a review of remote sensing applications *Afr. J. Aquat. Sci.* **40** 1–7.
- [6] Tortajada C 2006 Water management in Mexico City metropolitan area *Int. J. Water Resour. Dev.* **22** 353–376.
- [7] Al-Omari A, Fayyad M, Jamrah A 2008 Drinking water quality in roof storage tanks in the city of Amman *Jordan, Water Int.* **33** 189–201.
- [8] Djalilov A, Juraeva N, Nazarov O, Urolov S 2020 *IOP Conf. Ser.: Earth Environ. Sci.* **614** 012044.
- [9] Abdullah A 2008 Eater Level in Tank acing Sensors and PID Controller, Btech Thesis, University Malaysia Sarawak, Sarawak.
- [10] Khaled Reza SM, Shah Ahsanuzzaman Md. Tariq, Mohsin Reza SM 2010 Microcontroller Based Automated Water Level Sensing and Controlling: Design and Implementation Issue, Proceedings of the World Congress on Engineering and Computer Science, San Francisco, USA.
- [11] Anthony TW, Ahmad RG 2004 Introduction to Engineering Experimentation, PEARSON, New Tersey, USA.
- [12] Centurelli F, Monsurro P, Trifiletti A 2010 Behavioral modeling for calibration of pipeline analog-to-digital converters *IEEE Trans. Circuits and Systems I: Regular Papers* **57** 1255-1264.
- [13] Robert BN 2005 Introduction to Instrumentation and Measurements, Taylor & Francis Group., New York.
- [14] Anthony TW, Ahmad RG 2004 Introduction to Engineering Experimentation, PEARSON, New Tersey, USA.
- [15] Shaumburg X 2002 Sensors, Tashkent.
- [16] Arbuzov VP 2008 Structural methods of increasing the measurement of current capacitive and inductive sensors, Information publishing center PGU, Penza.
- [17] Jata KV, Kundu K, Parthasarathy TA 2010 An introduction to failure mechanisms and ultrasonic inspection. Advanced Ultrasonic Methods for Material and Structure Inspection, *Wiley-ISTE*, UK.
- [18] Kundu T, Placko D 2010 Advanced Ultrasonic Methods for Material and Structure Inspection, *Wiley-ISTE*, UK.
- [19] Barski M, Kedziora P, Muc A, Romanowicz P 2014 Structural Health Monitoring (SHM) methods in machine design and operation *Arch. Mech. Eng.* **61** 653–677.
- [20] Djalilov A, Sobirov E, Nazarov O, Urolov S 2021 *IOP Conf. Ser.: Earth Environ. Sci.* **868** 012031.