

PAPER • OPEN ACCESS

Study on the effective use of solar and hydro energy for powering agriculture and water management

To cite this article: D Kodirov *et al* 2023 *IOP Conf. Ser.: Earth Environ. Sci.* **1142** 012029

View the [article online](#) for updates and enhancements.

You may also like

- [Assessment of wind and hydropower potential of Bukhara region](#)
N N Sadullaev, A B Safarov, R A Mamedov *et al.*
- [Innovative methods of developing solar power systems for remote and agricultural facilities in Uzbekistan](#)
A Isakov, A Mirzabaev, O Sitdikov *et al.*
- [Development of a laboratory nozzle chamber installation for the humidification of buildings](#)
Kh Isakhodjayev, F Mukhtarov, D Kodirov *et al.*



244th Electrochemical Society Meeting

October 8 – 12, 2023 • Gothenburg, Sweden

50 symposia in electrochemistry & solid state science

▶ Deadline Extended!
Last chance to submit!

New deadline:
April 21
submit your abstract!

Study on the effective use of solar and hydro energy for powering agriculture and water management

D Kodirov^{1*}, Kh Muratov¹, A Davirov¹, J Normuminov², B Mamadjanov³,
A Shukuraliyev³, I Berdiyorova⁴, and Sh Musayev⁴

¹National Research University “Tashkent Institute of Irrigation and Agricultural Mechanization Engineers”, 100000 Tashkent, Uzbekistan

²Tashkent State Technical University, 100095 Tashkent, Uzbekistan

³Andijan Machine-building Institute, 170100 Andijan, Uzbekistan

⁴Jizzakh Polytechnic Institute, 130100 Jizzakh, Uzbekistan

*E-mail: kodirov.dilshod@gmail.com

Abstract. This article highlights the combined use of solar and hydropower based on a rational combination of traditional and renewable energy sources for powering agriculture and water management. At the same time, a combined integrated power supply system was formed. Provided, the energy is required from renewable sources, it fully provides the consumer, and the excess energy is transferred to the centralized network (N¹), if the energy received from the network is less than the energy entering the network, the recommended system is efficient (N²).

1. Introduction

To fulfill the needs of a growing population and rising food consumption, the need for energy in agriculture has considerably expanded [1, 2]. For which not only the currently available sources of energy are insufficient and getting scarcer as their reserves get smaller. Therefore, in addition to other areas for agricultural development, agro-researchers are particularly interested in the study of the investigation of new sources of energy.

Due to its lower risk than fossil fuels, as well as the declining cost of solar, wind, and battery-related technologies, renewable energy is gaining popularity in agricultural applications [3, 4]. As an illustration, reaching 100% renewable energy by 2050 is achievable across all industries and is growing more economically and technically feasible every year [5].

Due to its many benefits over other renewable energy sources, including its high energy density, low cost, and dependability, hydropower is the most extensively used renewable energy source globally [6]. There are hydropower facilities in sizes ranging from a few Kilowatts (kW) to many Gigawatts (GW). Small hydropower plants, typically in the kW range, are utilized to electrify rural areas in many nations and have a strong potential to be included into the value chain of agriculture in those regions [7-12].

The basic operating principle of hydropower, especially small-scale hydropower (up to 1 MW), is as follows: water from streams or rivers flows through a turbine, which rotates and operates machinery (such as pumps, mills, etc.) or a generator that can generate electricity. It is crucial to have thorough understanding of the local water resources and to build the system appropriately in order to obtain a dependable generation of energy [13, 14].

On the other hand, due to their self-sufficiency and low energy prices, solar energy applications in agriculture are expanding for irrigation, lighting, heating, cooling, and drying, which eventually lowers production costs and saves a sizeable amount of investment [15, 16]. Solar energy is also getting more cost-effective and efficient, which effectively lowers global warming and makes it a practical answer for climate change issues [17-21]. The inverters are also contained in soundproof casing, and the solar



module has no moving parts. As a result, the "agrivoltaic" system, which may be placed quite close to loading centers in an urban area, barely makes any noise. By lowering line losses, this technology could lessen transmission difficulty while also increasing module efficiency.

A significant increase in the efficiency of the power supply system depends on technical solutions. Therefore, it is necessary to develop technical solutions for the efficient use of not only renewable, but also traditional sources in an integrated energy supply system [18-21].

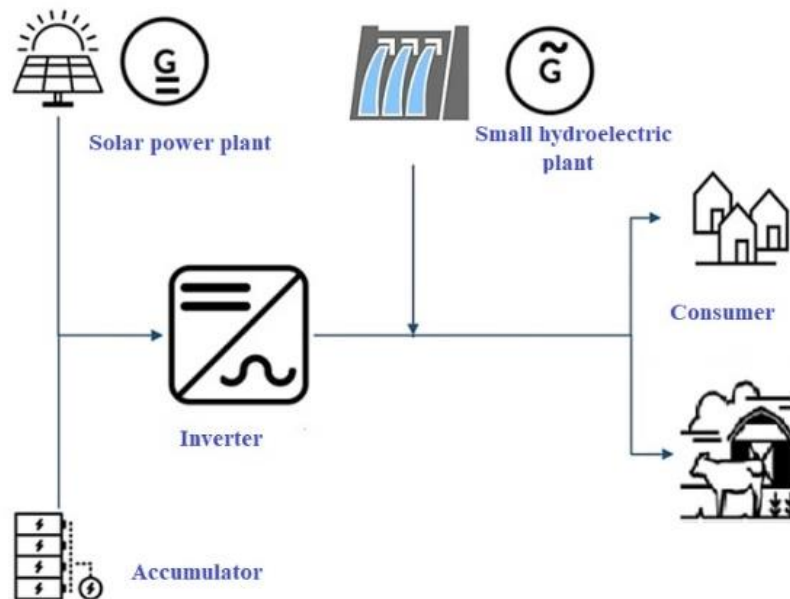

Figure 1. A combination of solar ES and small hydropower plants

Currently, there are various technical and circuit solutions that allow the use of solar and hydro power plants separately and jointly [11, 12]. The most urgent problem is the combined use of solar and water energy. With their simultaneous use, it is necessary to maximize the use of incoming flows of renewable energy and thereby increase the efficiency of their use. Appropriate solutions must be developed to meet these conditions. The developed technical and circuit solutions should be based on the principle of harmonization of renewable and traditional sources with each other. In this case, it is necessary to proceed from the condition of ensuring the daily need for energy.

Hydro turbine produces alternating current. Solar power plant constantly produces electricity. The resulting direct current is converted into alternating current using an inverter. Part of the electricity generated by the solar power plant is delivered to the consumer, and part is used to charge the battery. When the battery is fully charged, the controller turns it off and the generated energy is completely transferred to the consumer (see Figure 1). The increase in power consumption reduces the voltage at the output of the hydro turbine, and if the stabilizer cannot maintain the required voltage, the required energy is taken from the solar power plant or the battery. The amount of electricity it produces is controlled by a power regulator, where the consumer can get electricity from a hydro turbine or a solar power plant.

2. Methods

When there is no water flow or its speed is low and the solar power plant cannot deliver the required power, the consumer receives electricity from the centralized power supply system. After the decentralized power supply system is fully restarted, the consumer is automatically disconnected from the centralized power supply system by the power regulator. If there are no or few consumers of

electricity, the energy generated by the decentralized power supply system is sent to the centralized power grid by the power regulator (see Figure 2) [6, 7, 8].

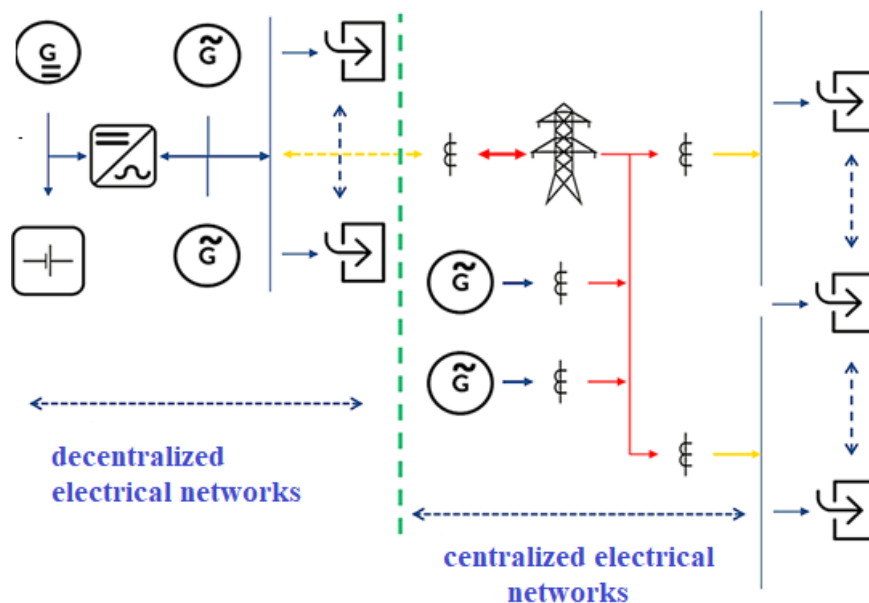

Figure 2. A combination of centralized and decentralized power supply system

Thus, the proposed electricity supply system for decentralized electricity supply to consumers will allow agricultural and hydropower consumers to increase the efficiency of renewable energy use. The proposed schemes allow the development of technical solutions for the coordinated supply of traditional and renewable energy sources in the power supply system and the calculation of their operating modes. The energy efficiency assessment algorithm of the centralized and decentralized power supply system is presented in Figure 3. In this case, if the consumer (N1) is not fully supplied with renewable energy (N2), the necessary energy is obtained from the centralized energy supply (N'). The energy obtained from the renewable source can fully supply the consumer and transfer the excess energy to the centralized grid (N''). If the energy received from the grid is less than the energy supplied to the grid, the proposed system is considered efficient (N''').

Currently, the visual modeling system is a convenient tool for analyzing complex dynamic systems and is widely used in various scientific and engineering studies. The main advantages of the visual modeling system:

- the ability to express any model in the form of a hierarchical structure;
- the possibility of virtual interconnection of all the blocks of the implemented model and the possibility of evaluating the errors that come to the surface;
- the ability to monitor processes occurring in the system during simulation using the Simulink program.

The Karasuv canal of the Tashkent region was selected for the development, installation and testing of integrated solar ES and small hydropower plants using visual modeling (see Figure 4).

According to the results of the research, the width of the Karasuv canal flowing through Khosilot neighborhood of Qibray district is 28 meters, the average pressure is 4 meters, the water consumption is 3 m³/s, and the intensity of solar radiation in the selected area is 4.6 kW/m² per day on average.

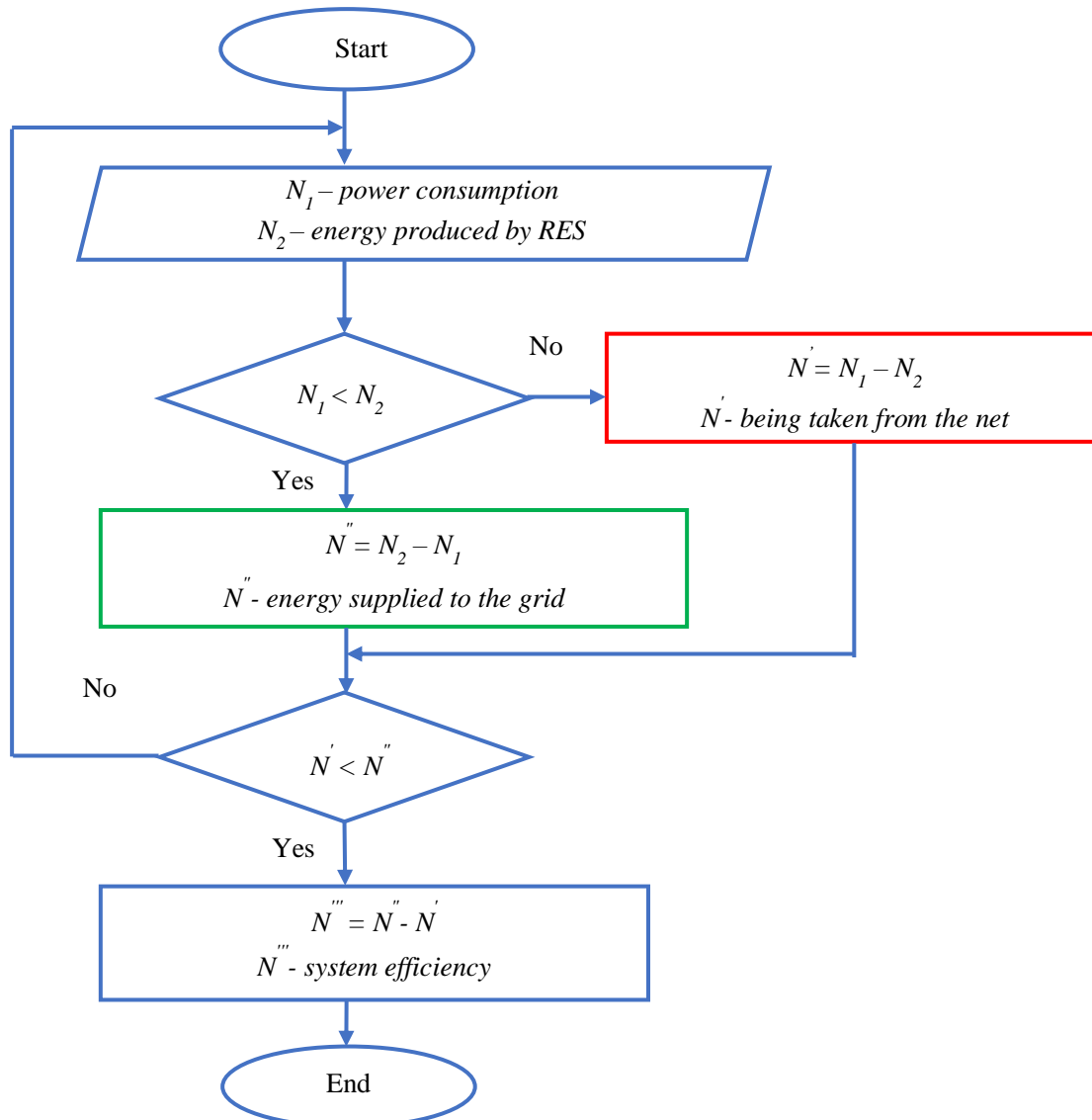

Figure 3. Is the system performance evaluation algorithm



Figure 4. Karasuv canal in Kibrai district

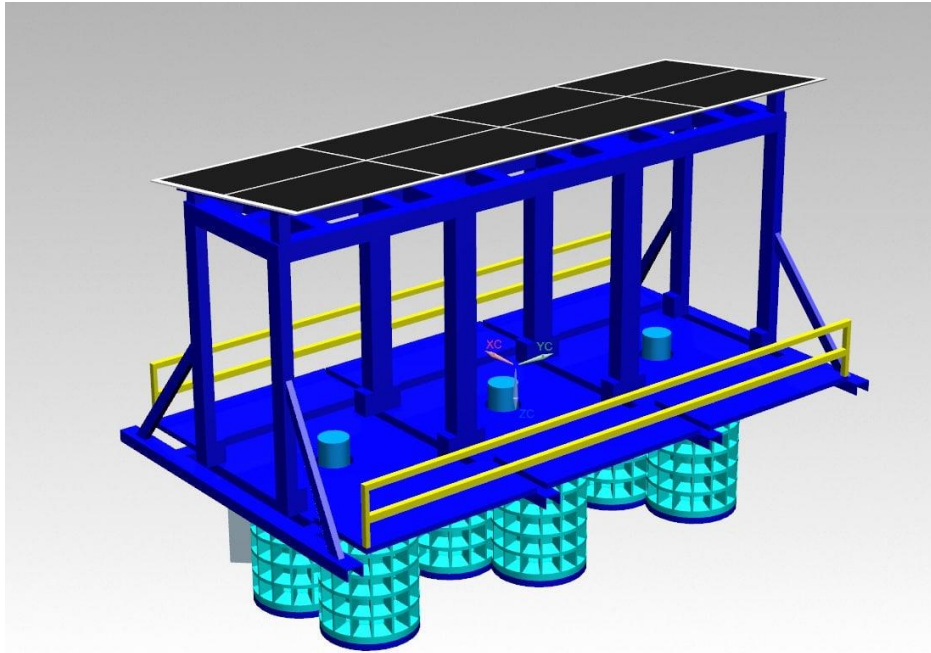

Figure 5. Combined solar ES and small hydropower visual model

The technical, operational and design parameters of the combined plant of solar ES and small hydroelectric power station were placed according to the visual model for installation (see Figure 5). The developed combined visual model of solar ES and small HPP allows to simulate the operation in different conditions. Thus, in the simulation model, it is possible to see the effect of the flow of water in the two blocks on the hydro turbines.

3. Results and Discussions

A unique feature of the simulation model is that it allows the maximum kinetic energy of the water flow to be used. In this case, a vane directing water directly to the turbine is placed so that the turbines of the hybrid device, placed transversely to the water flow, always move in one direction. To increase mechanical power, two turbines are simultaneously connected to one generator using a belt drive (see Figure 6).

The size of a small hydroelectric turbine depends on the water velocity (v), the volume of water hitting the turbine blades at a fixed moment of time (Q) and the depth of the water surface (N). The energy efficiency is high when the outer diameter of the turbine is $d_1 \geq 2d_2$. The internal depth of the pipe is determined empirically as follows (Eq. 1):

$$\gamma = k^3 \sqrt{\frac{d_1}{d_2}}, \quad (1)$$

where $0.6 \leq k \leq 0.7$ is the effect coefficient of water on the turbine. Pipe width expressed using the formula (Eq. 2):

$$X = \frac{Q}{vk\gamma} \quad (2)$$

The inner surface of the turbine is determined using equation (3):

$$S = \gamma X \left[1 + \frac{\cos 2\theta}{\sin \theta} \right], \quad (3)$$

where θ is the angle between the wings directing water to both sides, the angle θ is an important quantity for the proposed hydrotube. We need to choose this angle so that, as a result, the impact of two turbines placed on one device with water should be maximum, and the torque should be minimum, this angle is determined using the following formula (Eq. 4) (see Figure 7):

$$\theta = 180^\circ - \arcsin\left(\frac{d_1 - 2E}{d_1}\right), \quad (4)$$

where E is the length of the sheet and determined using the formula below (Eq. 5):

$$E = \sqrt{X^2 + \gamma^2} \quad (5)$$

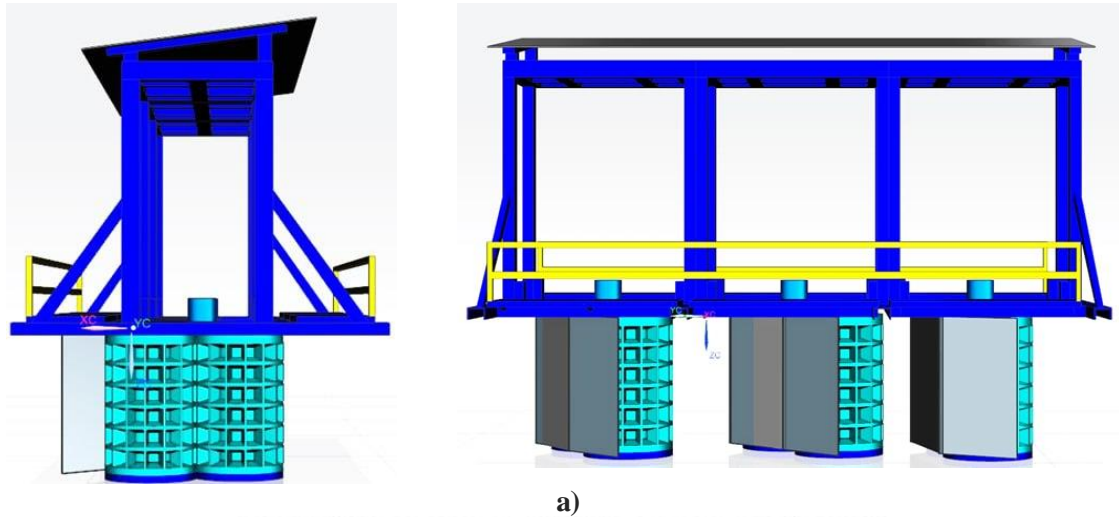

a)

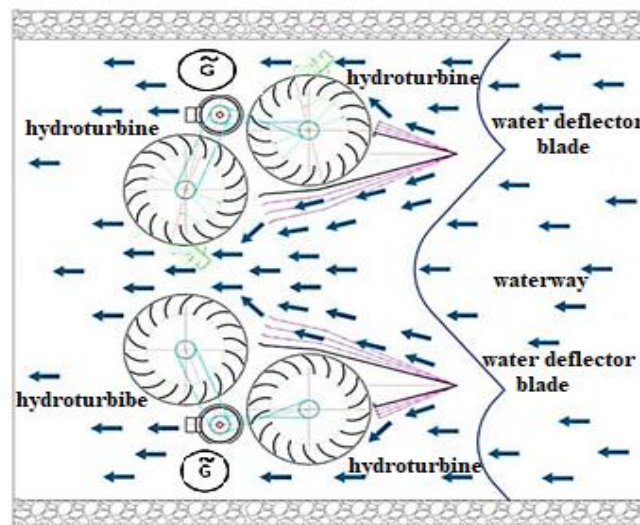

b)

Figure 6. Simulation model of water flow, turbine and generator motion: side view (a) and bottom view (b)

Now we find the mass of water acting on the turbine, that is, the mass of water falling between the blades. The mass of water is determined by the following differential equation (6):

$$\frac{dm}{dt} = \rho S(v - \bar{v}), \quad (6)$$

where ρ is the density of water, and \bar{v} is the speed of water after hitting the film. Turbulence happens when the wing moves along the water flow, so its speed \bar{v} differs from the usual speed n , that is, $\bar{v} = \partial v$, which is in the range $0 < \partial < 1$.

The angular speed of the turbine is found directly depending on the linear speed \bar{v} (Eq. 7):

$$\varphi = 4v/[d_1(1 + \cos \theta / \sin \theta)] = \bar{v} \frac{d_1}{2}. \quad (7)$$

The force acting on the turbine blades (F) is also a variable and is found by the following differential equation (8):

$$F = \frac{d}{dt} (m(v - \bar{v})) = \rho S v^2 (1 - \theta^2). \tag{8}$$

In order to determine the force (8) acting on the blades from a physical point of view, we must first find the "transmitting force" F_p and the pulling force F_t .

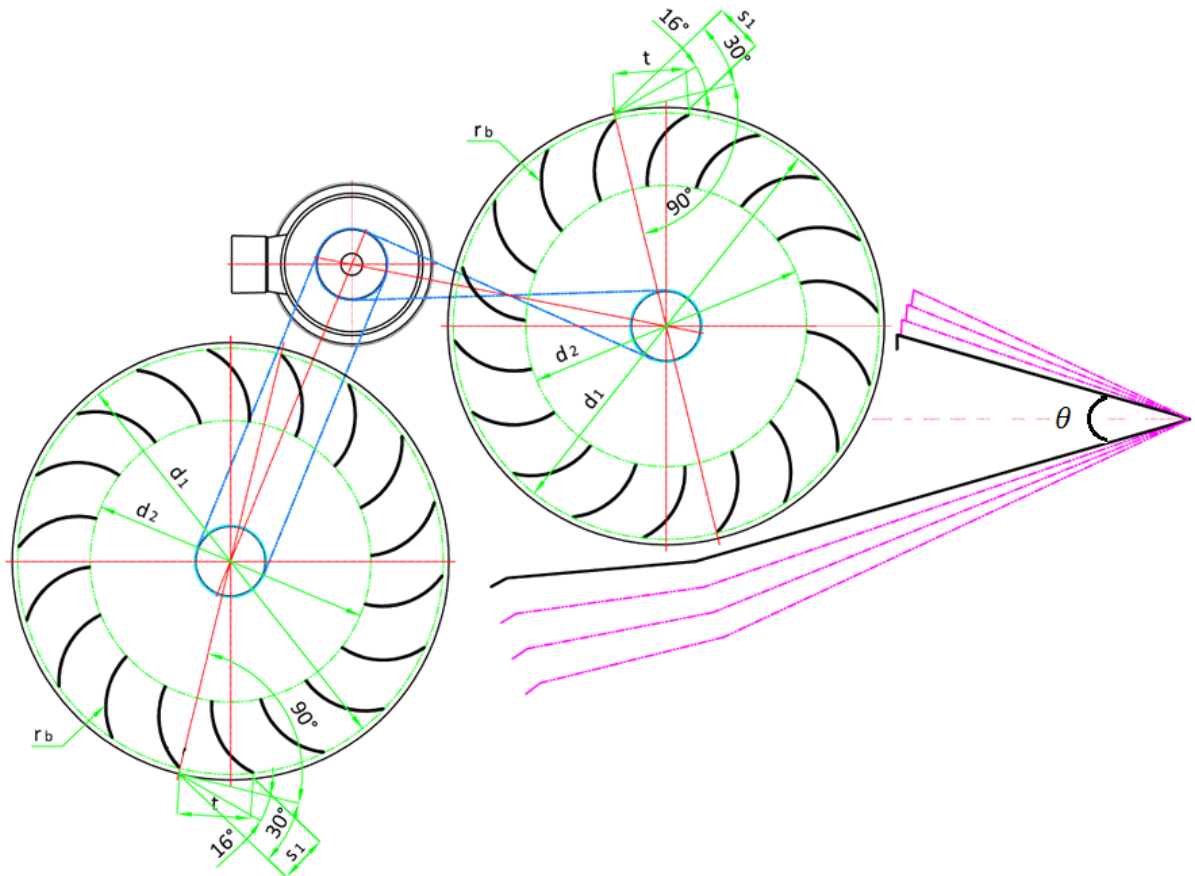

Figure 7. Dimensions of hydroturins

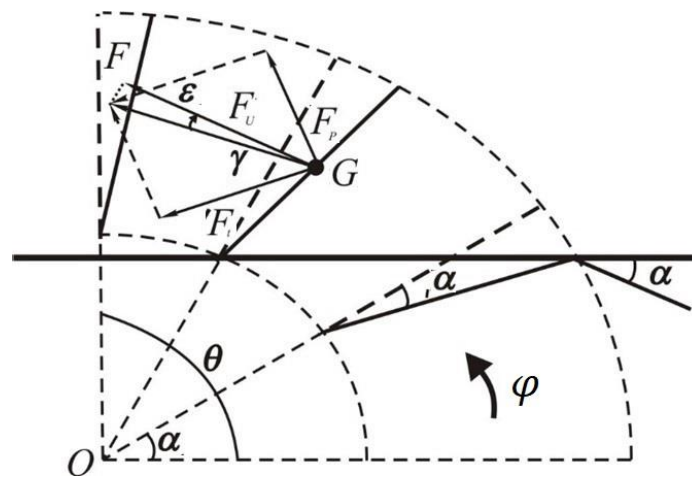

Figure 8. Forces acting on the turbine

The tensile force F_p and the tensile force F_t are respectively determined using the following formula (Eq. 9):

$$F_p = \mu \frac{\rho}{2} \bar{v}^2 S, \quad F_t = \eta \frac{\rho}{2} \bar{v}^2 S \quad (9)$$

where μ, η are proportionality coefficients. Since the forces determined by formulas (8) are vector quantities, the equally acting force F can be represented as the sum of two vectors (Eq. 10) (see Figure 8).

$$F = \sqrt{F_p^2 + F_t^2} \quad (10)$$

From this, the useful force acting at an angle ε (Eq. 11):

$$F_u = F \cos \varepsilon, \quad (11)$$

where $\varepsilon = \arctan \frac{\mu}{\eta} - (\alpha - \gamma)$.

In order to ensure the closeness of the mathematical model to the real process, we will study the rotation law of the turbine. Let's say that the partitions are $U_{i,i=1,2,\dots,n}$, where n is the number of partitions. Let's assume that it is a body rotating with a speed whose wings are fixed with respect to the Oz axis, the angle φ determined using the formula (4.28). According to the theorem on the change of kinetic moment (Eq. 12):

$$\frac{dK}{dt} = U_1(F_u) + U_2(F_u) + \dots + U_n(F_u) = \sum_{i=1}^n U_i(F_u). \quad (12)$$

Kinetic moment due to rotation of a rigid body around a fixed Oz axis (Eq. 13):

$$D = B_z \varphi \quad (13)$$

is found using the formula, where B_z is the moment of inertia of the mechanical system relative to the axis of rotation Oz at a fixed time, it is found using the following formula (Eq. 14):

$$B_z = m_1 r^2 + m_2 r^2 + \dots + m_n r^2 = \sum_{k=1}^n m_k r^2 \quad (14)$$

Using formula (13), we write the differential equation (10) in the following form (Eq. 15):

$$B_z \frac{dw}{dt} = \sum_{i=1}^n U_i(F_u). \quad (15)$$

It is known from the kinematics of a rigid body (Eq. 16):

$$w = \frac{d\theta}{dt} = \dot{\theta}, \quad (16)$$

here, the angle of rotation of the turbine relative to the Oz axis.

As a result, we get (Eq. 17):

$$B_z \frac{dw}{dt} = B_z \frac{d^2\theta}{dt} = \sum_{i=1}^n B_i(F_u), \quad (17)$$

the expression is called the differential equation of rotation of a rigid body around a fixed axis. In equation (17), the moment of inertia B_z is an analogue of the mass m determined from the formula (6), $\frac{d^2\theta}{dt}$ - performs the role of linear acceleration, and the sum $\sum_{i=1}^n U_i(F_u)$ is the effect F acts as the main vector of forces. Usually the turbine is affected by several forces determined by the formula (11), so $F_u = \sum_{k=1}^n F_u^k$. Under the influence of forces $\{F_u^1, F_u^2, \dots, F_u^n\}$, reactions R_1 and R_2 are generated in the bearings on the shaft axis, these reactions are also an external force, but their moment is zero relative to the Oz

Now we find the work done as a result of the rotation of the turbine. Let the turbine blade $U_i, i=1,2,\dots,n$ be affected by the force F_u determined by the formula (11) at an angle α . The work done by this force is equal to the work done to turn the turbine. Therefore, the work done (Eq. 18):

$$dA = F_u \cdot r \cdot \sin \theta d\theta. \quad (18)$$

Considering that the moment of force (13) relative to the axis of rotation is $D = F_u r \sin \alpha$, we have the following formula (Eq. 19):

$$dA = D d\theta \quad (19)$$

Integrating both sides of the equation (19), we find that the work when the turbine is turned to a finite angle $d\theta$ is equal to the integral sum of the total works, that is (Eq. 20):

$$A = \int_{\theta_1}^{\theta_2} D d\theta. \quad (20)$$

So, the work done during the rotation of the turbine is equal to the product of the torque and the angle of rotation.

4. Conclusions

Summarizing the research results related to this work, we can draw the following conclusions:

- a) for the first time, a model was developed for calculating the share of energy exchanged from solar power plants and hydroelectric plants in separate and joint use, at the same time, the possibility of choosing solar and hydroelectric plants according to the conditions of daily necessary energy supply was determined;
- b) Analytical expression was obtained when choosing optimal solutions for solar power plants and hydroelectric plants, and the continuity and reliability of the energy supply system was evaluated by coordinating the modes of supply and consumption of renewable energy;
- c) for the first time, a rational combination algorithm of renewable and traditional energy sources and a model for calculating their operating modes were developed, and the economic efficiency of the new energy supply system was evaluated through it;
- d) The results of the research are of theoretical and practical importance, and using the obtained methods, models and algorithms, they play an important role in the assessment of electricity consumption in agriculture and water management and the determination of the required energy standards, the use of renewable energy sources and their wide implementation in practice.

References

- [1] Calicioglu O, Flammini A, Bracco S, Bellù L, Sims R 2019 The Future Challenges of Food and Agriculture: An Integrated Analysis of Trends and Solutions *Sustainability* **11** 222.
- [2] Godfray HC, Crute IR, Haddad L, Lawrence D, Muir JF, Nisbett N, Pretty J, Robinson S, Toulmin C, Whiteley R 2010 The future of the global food system. *Philosophical transactions of the Royal Society of London Series B Biological sciences* **365**(1554) 2769–2777.
- [3] Gielena D, Boshell F, Saygin D, Bazilian M, Wagner N, Gorini R 2019 The role of renewable energy in the global energy transformation *Energy Strategy Reviews* **24** 38-50.
- [4] Kaushik Ch 2011 Renewable energy for sustainable agriculture *Agronomy for Sustainable Development* **31**(1) 91-118.
- [5] Ram M et al. 2017 Global Energy System Based on 100% Renewable Energy—Power Sector, Lappeenranta University of Technology and Energy Watch Group, Lappeenranta, Finland.
- [6] Kaunda ChS, Kimambo CZ, Nielsen TK 2012 Hydropower in the Context of Sustainable Energy Supply: A Review of Technologies and Challenges *International Scholarly Research Notices* **2012** 730631.
- [7] Uamusse MM, Tussupova K, Persson KM, Berndtsson R 2019 Mini-Grid Hydropower for Rural Electrification in Mozambique: Meeting Local Needs with Supply in a Nexus Approach *Water* **11** 305.
- [8] Kodirov D, Tursunov O 2019 Calculation of Water Wheel Design Parameters for Micro Hydroelectric Power Station *E3S Web of Conferences* **97** 05042.
- [9] Kodirov D, Tursunov O, Parpieva S, Toshpulatov N, Kubyashev K, Davirov A, Klichov O 2019 The implementation of small-scale hydropower stations in slow flow micro-rivers: a case study of Uzbekistan *E3S Web of Conferences* **135** 01036.
- [10] Kodirov D, Tursunov O 2020 Modeling and analysis of a reactive low-pressure hydraulic turbine *IOP Conference Series: Materials Science and Engineering* **883** 012085.
- [11] Kodirov D, Muratov Kh, Tursunov O, Ugwu E, Durmanov A 2020 The use of renewable energy sources in integrated energy supply systems for agriculture *IOP Conference Series: Earth and Environmental Science* **614** 012007.

- [12] Kodirov D, Tursunov O, Ahmedov A, Khakimov R, Rakhmatiev M 2020 Economic efficiency in the use of solar energy: A case study of Agriculture in Uzbekistan *IOP Conference Series: Earth and Environmental Science* **614** 012031.
- [13] Kodirov D, Tursunov O, Khushiev S, Bozarov O, Tashkhodjaeva G, Mirzaev S 2020 Mathematical description of water flow quantity for microhydroelectric station *IOP Conference Series: Earth and Environmental Science* **614** 012032.
- [14] Kodirov D, Tursunov O, Karimova Kh, Akramova N, Parpieva S, Shafkarov B 2020 Application of hydro energy in small power supply systems *IOP Conference Series: Earth and Environmental Science* **614** 012037.
- [15] Kata R, Cyran K, Dybka S, Lechwar M, Pitera R 2021 Economic and Social Aspects of Using Energy from PV and Solar Installation in Farmer's Households in the Podkarpackie Region *Energies* **14** 3158.
- [16] Mekhilef S, Faramarzi SZ, Saidur R, Salam Z 2013 The application of solar technologies for sustainable development of agricultural sector *Renewable and Sustainable Energy Reviews* **18** 583-594.
- [17] Anarbaev A, Tursunov O, Kodirov D, Muzafarov Sh, Sanbetova A, Batirova L, Mirzaev B 2019 Reduction of greenhouse gas emissions from renewable energy technologies in agricultural sectors of Uzbekistan *E3S Web of Conferences* **135** 01035.
- [18] Anarbaev A, Tursunov O, Zakhidov R, Kodirov D, Rakhmatov A, Toshpulatov N, Namozov S, Sabirov E 2020 Calculation the dynamic stability zone of the distribution grid with generating sources based on renewable energy *IOP Conference Series: Earth and Environmental Science* **614** 012004.
- [19] Isakov A, Mirzabaev A, Sitdikov O, Makhkamova M, Kodirov D 2020 Innovative methods of developing solar power systems for remote and agricultural facilities in Uzbekistan *IOP Conference Series: Earth and Environmental Science* **614** 012014.
- [20] Kodirov D, Tursunov O, Talipova D, Shadmanova G, Parpieva S, Shafkarov B 2020 System approach to renewable energy use in power supply *IOP Conference Series: Earth and Environmental Science* **614** 012038.
- [21] Mirzabaev A, Isakov A, Mirzabekov Sh, Makhkamova T, Kodirov D 2020 Problems of integration of the photovoltaic power stations with the grid systems *IOP Conference Series: Earth and Environmental Science* **614** 012016.